

KudosPro

Single, Dual and Quad Channel Format and Frame-rate Conversion



Supporting all broadcast formats, offering a wide range of I/O connectivity and delivering a complete processing toolkit, KudosPro is a dependable solution for even the most unexpected situations.

Three Ranges for All Applications

KudosPro™ is the audio and video processing platform from Grass Valley®, delivering high-quality audio and video signal processing in an affordable and format-flexible package. KudosPro is the ideal solution for broadcasters, news agencies and content providers needing to consider cost and space issues, while also ensuring high-quality content for domestic and international audiences. Redundant power supplies in all models, plus comprehensive support means all KudosPro ranges work for your business, and keep working for your business.

Utility Series

- Audio video processors for standalone up/down/crossconversion and processing applications
- Dual and quad video channel options
- Massive audio processing capabilities all in compact 1 RU chassis with front panel controls

International Series

- Frame-rate conversion using linear interpolation techniques
- Audio video processors for standalone up/down/crossconversion and processing applications
- Single, dual and quad video channel options
- Massive audio processing capabilities all in compact 1 RU chassis with front panel controls

Motion Series

- High-quality motion compensated frame-rate conversion
- Audio video processors for standalone up/down/crossconversion and processing applications
- Single and dual video channel options plus massive audio processing capabilities
- All in compact 1 RU chassis with front panel controls

Highest Quality/Highest Density

KudosPro offers up to four video processing channels in both Utility and International series in 1 RU for a high level of conversion processing density.

Maximum Interfacing and Audio Processing

KudosPro products offer a full range of input and outputs via physical interfaces, so whatever your interfacing challenges, Grass Valley can help. Audio processing capabilities across the range are comprehensive via embedded, discreet AES or analog inputs and outputs.

MC1000 and MC2000

Motion Compensated Frame-rate Conversion

Motion compensated single channel (MC1000) and dual channel (MC2000) SD/HD/3G frame-rate converter with powerful enhancement and processing tools.

Affordable International Program Exchange

The superb frame-rate conversion capabilities of the MC1000 and MC2000 enable program makers and content owners to offer high-quality material to worldwide customers, while keeping project costs down.

LC2000 and LC4000

Linear Motion Adaptive Frame-rate Conversion

Dual or quad channel (LC2000/LC4000) SD/HD/3G linear frame-rate converters with motion adaptive up/down/crossconversion.

High Density Conversion

Immediate and flexible selection of a wide range of digital and analog input and output formats, from SD up to 3 Gb/s.

SV2000 and SV4000

Up/Down/Crossconversion

Dual-channel (SV2000) and quad-channel (SV4000) SD/HD/3G video and audio processing including frame synchronizer and motion adaptive up/down/crossconversion.

Saving Production Costs

Smoothly integrate mixed SD/HD/3G produced content or incoming feeds ready for any outgoing transmission standard.

HD and Beyond

Viewers of SD and HD services can continue to watch their favorite programs, even with transitional 3 Gb/s, HD and SD production workflows, through the provision of the quality assured up, down and crossconversion capabilities — ensuring valuable content assets remain viable for the long-term future in any format.

Flexible Workflows

Flexible, automated processing is another important capability within the KudosPro range. Sources can be switched between 3 Gb/s, HD and SD, and with all KudosPro products supporting automatic input detection, the most appropriate conversion mode can be immediately offered.

Full support for important metadata such as closed captions, timecode and AFDs is all provided as standard.

Simple and Intuitive Control

A simple web interface, as well as control via Grass Valley's award-winning GV Orbit® software, are available on all KudosPro products, enabling KudosPro to fit into any broadcast, playout or post-production workflow.

User control via simple front panel menus and short-cut buttons enables artistic decisions to be easily actioned, and the intuitive front panel display gives instant reassurance of the current system status.

Table of Contents

Introduction	3	LC2000 & LC4000	
MC1000 & MC2000		Motion Adaptive Frame-rate Converter.....	9
Motion Compensated Frame-rate Converter.....	6	SV2000 & SV4000	
		Up/Down/Crossconverters and Frame Sync	13

Whatever your conversion needs, the KudosPro range offers superb quality results.

All broadcast frame rates and formats are supported, ensuring great quality conversion for international content sources resulting in programs that look stunning, and give you an edge over competing converted channels.

Solves your Format Problems

The KudosPro range produces the consistent, high standard, 1080p, HD and SD pictures that viewers demand, with reliability and customer service expected from the Grass Valley brand, and its years of experience in conversion and signal processing products.

Peace of Mind

Rest assured that KudosPro is always ready to fix your signal problems, no matter how expected or unexpected they may be. The comprehensive feature set includes: audio delay/gain/shuffling, RGB legalizer, user selectable aspect ratio conversion, logo insertion, side-bar keying, extensive picture enhancement tools and video noise reduction.

Ease of Use

Integrating legacy and international programming into your schedules has never been easier. With Grass Valley's KudosPro range of converters, you're guaranteed to find a converter to meet your application and budget needs. Whether you need to frame rate or format convert, Grass Valley offers motion compensated and motion adaptive converters that ensure that the quality of your content is retained at every step in your workflow.

Ideal for international program exchange, conversion, high-density distribution and content repurposing for broadcast or internet applications.

Stills

KudosPro achieves maximum resolution preserving the fine detail in graphics and sharpness of text. Softness and lack of detail are typical artifacts which are seen in other products.

Action

In fast moving sports action, detail and definition around key parts of the images such as the ball or player are critical. KudosPro uses motion compensation to ensure full resolution and well defined motion. It is the only product that provides full resolution moving video images. Other products introduce blur and reduce resolution in moving areas.

Complex Pictures

A typical program output comprises many components such as station branding, credit rolls and video or animation. KudosPro handles all of these simultaneously without compromise. Other products cannot handle these types simultaneously. Therefore, image quality will be compromised.



Control is offered from the attractive and user-friendly front panel as well as a simple web interface. For large system users, KudosPro is fully compatible with Grass Valley's GV Orbit network orchestration solution.

Front Panel Control

User control via simple front panel menus and short-cut buttons enables artistic decisions to be easily actioned, while the intuitive front panel display gives instant reassurance of the current system status.

Remote Control

Control using a web browser or GV Orbit control panel (Grass Valley's proprietary control and monitoring application) is also available. Alternatively, you can integrate into enterprise-wide control & monitoring systems using SNMP.

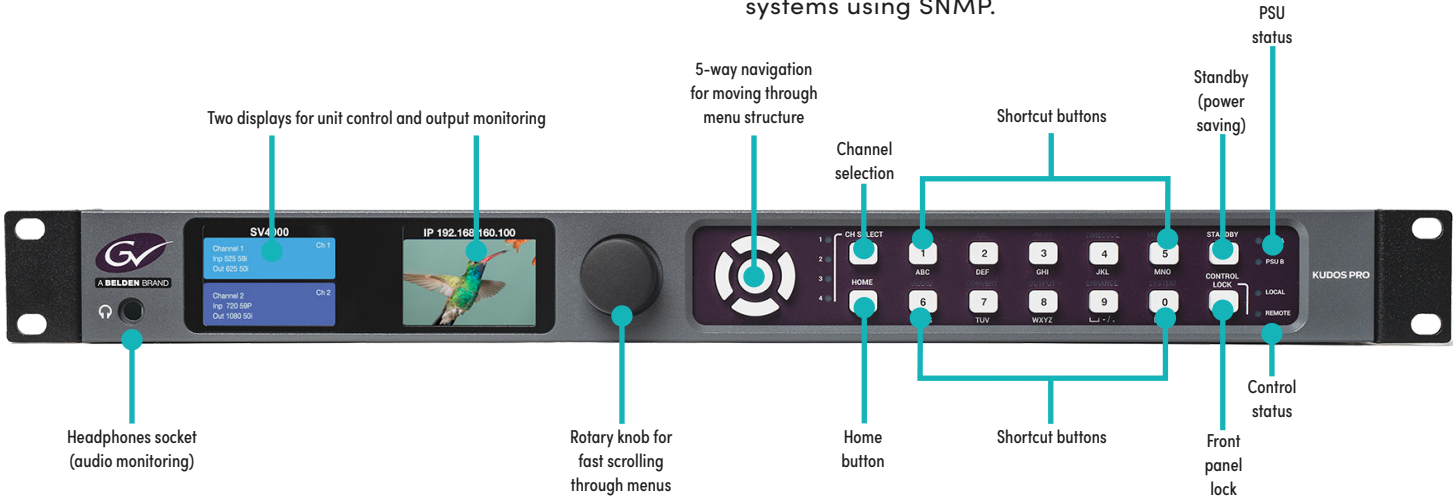

KudosPro offers a wide range of I/O connectivity and delivers a complete processing toolkit.

The KudosPro range has an array of digital and analog interfaces encompassing video formats from composite to 1080p, copper to fiber and a comprehensive selection of audio handling options and formats, including analog and AES – both balanced and unbalanced.

Audio I/O

AES I/O is available as balanced or unbalanced, providing complete flexibility no matter what environment you're in. Analog audio can be embedded and de-embedded into SD/HD/3G.

Video I/O

With both SDI and analog composite video interfaces, KudosPro is a completely flexible platform, handling SD, HD and 1080p over SDI or fiber.

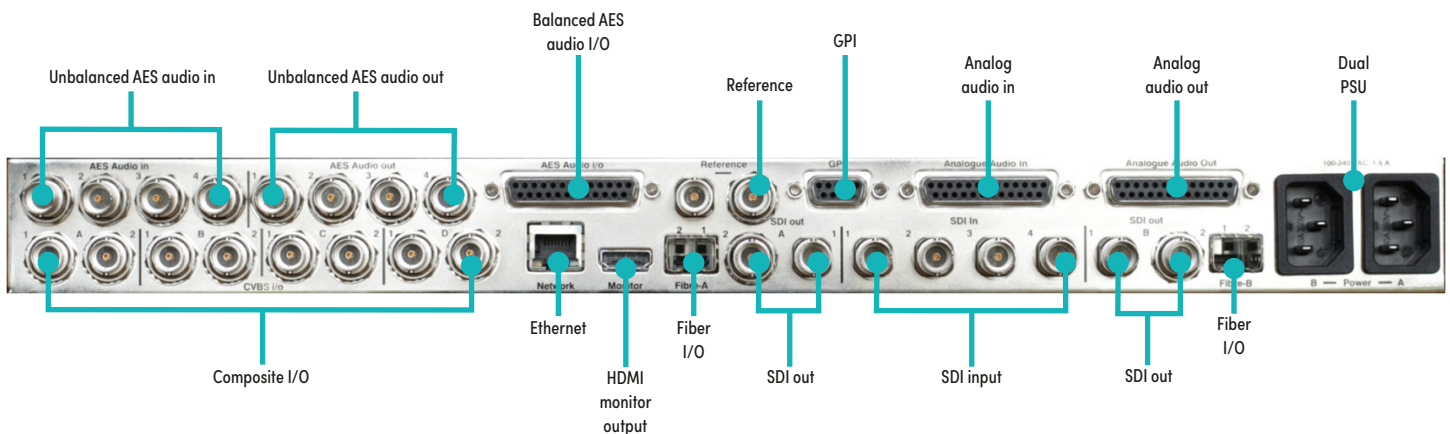

Not only do KudosPro products offer high-quality, affordable conversion within a compact enclosure, they also offer single, dual and quad channel frame synchronization with advanced video and audio processing capability, all within 1 RU, making KudosPro ideal for high-density production environments demanding the widest range of conversion possibilities – now and into the future.

Convert from any SD/HD/3G standard to any other SD/HD/3G 1080p standard, including 1080 and 720 23.98/24/25/29p and PsF. Create simultaneous HD and SD outputs from one input source (not applicable to MC1000). Choose from linear motion adaptive format conversion through to motion compensated frame-rate conversion, or select frame synchronization and relay bypass on primary SDI inputs.

Powerful picture enhancement tools:

- Noise reducer
- Enhancer
- Legalizer
- Proc amp

Additional video processing features, including:

- Logo insertion (one per channel)
- Side-bar keying
- Multiline WST, closed caption and AFD aspect ratio conversion features

Up to 16-channels of embedded audio processing are available for each video channel. Audio handling includes: audio embedding, audio de-embedding, audio gain, audio delay, audio shuffle and audio swap.

Applications

OB Truck/Studio

Work with up to four channels of SD and HD content simultaneously in any form within a single 1 RU enclosure. KudosPro adapts with you, and on demand, because we recognize that no two events are ever the same.

Post/Facility Production

From 23.98, 24, 25 to 50p and 60p KudosPro converts seamlessly between all international standards with the quality you'd expect from Grass Valley, at an incredibly affordable price point.

Ingest

Handle multiple channels within the 1 RU high-density design for use in front of our ingest servers, bringing content into your house format – no matter what format it is originally received/stored in. And KudosPro quickly “fixes” audio & video problems.

Hire

Never really know what your clients are going to ask for? Don't worry. KudosPro has complete analog and digital flexibility from analog audio with composite to 1080p 3 Gb/s with AES audio. Plus the user interface is simple and intuitive, so you won't have calls asking how to set up and use the unit(s).



Satellite, Head-end Applications

Remote control and monitoring and dual PSUs give you the reliability and peace of mind critical for remote locations.

MC1000 & MC2000



Motion Compensated Frame-rate Converter

The MC1000 and MC2000 are high-quality, single- and dual-channel motion compensated frame-rate converters.

Key Features

- Motion compensated SD/HD/3G frame-rate conversion
- Independent dual channel conversion (MC2000 only)
- SD/HD/3G up/down/crossconversion
- Flexible video and audio I/O configuration
- 16-channel embedded audio processing for each video channel
- Continuous output when input standard switches
- HDMI monitor output
- Dual PSU as standard
- Relay bypass on primary SDI inputs
- Automatic aspect ratio conversion (AFD, VI, L23)
- Powerful picture enhancement tools
- Front panel and remote control via web interface and GV Orbit
- Closed caption and timecode handling
- Synchronization
- User chosen line for SMPTE ST 2016
- GPI support
- Front panel control lock
- Caption generator
- Logo inserter
- Sidebar keyer
- Clean cut
- Composite input/output
- Fiber input/output

Applications

- International program distribution
- Content repurposing for internet, TV and Blu-ray distribution
- International TV and video production

MC1000 Video Processing

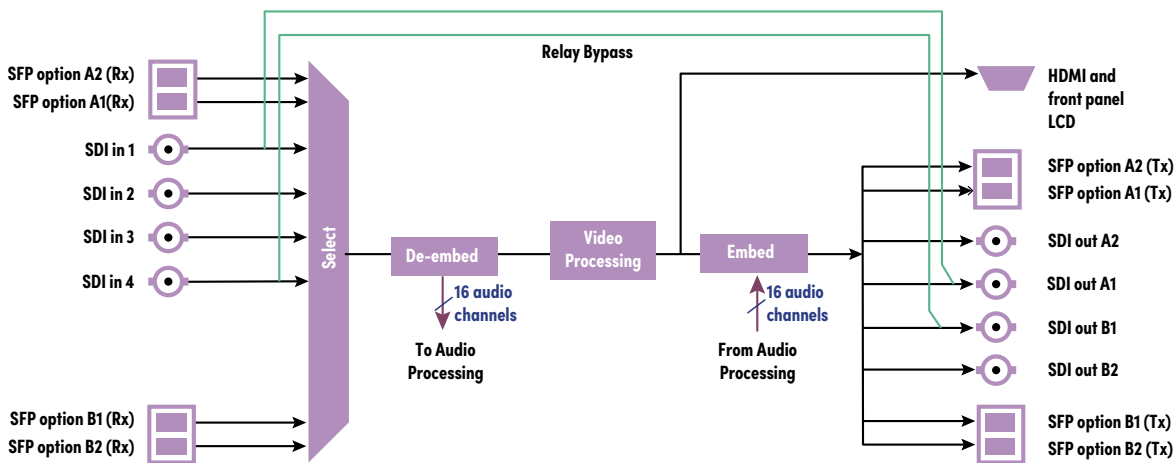

MC1000 Audio Processing

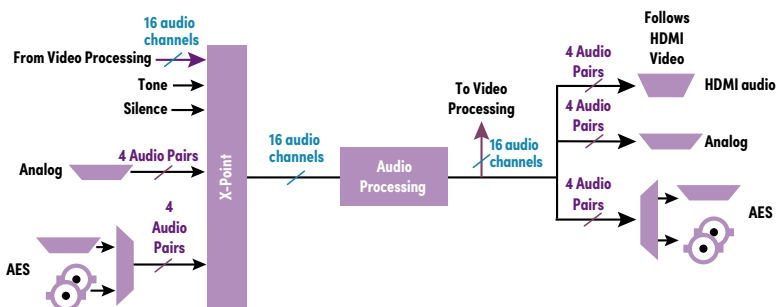

MC2000 Video Processing

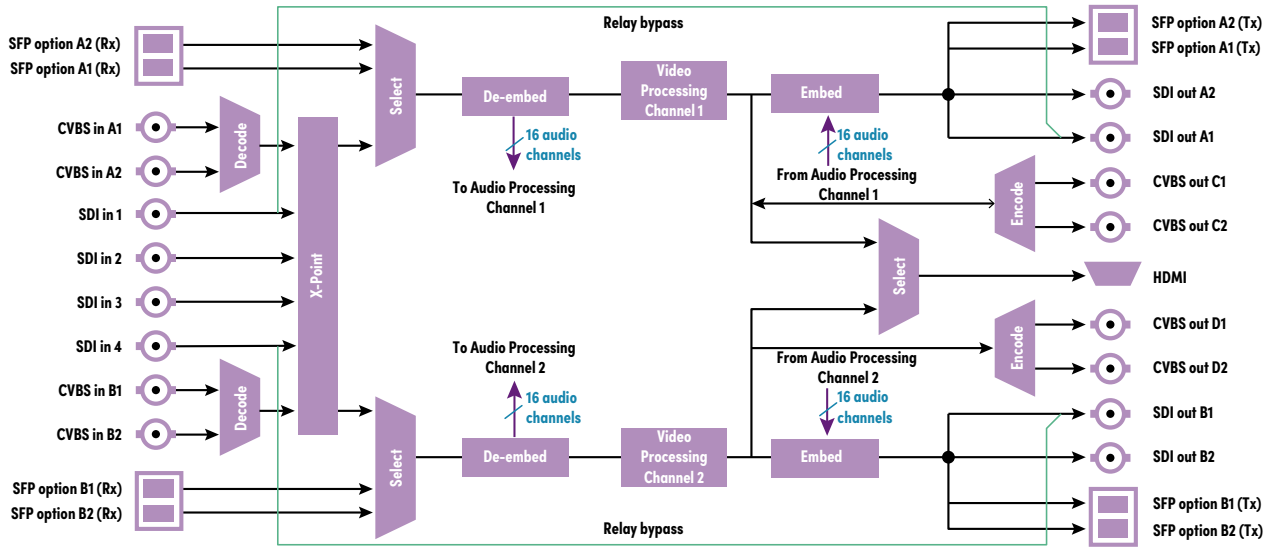

MC2000 Audio Processing

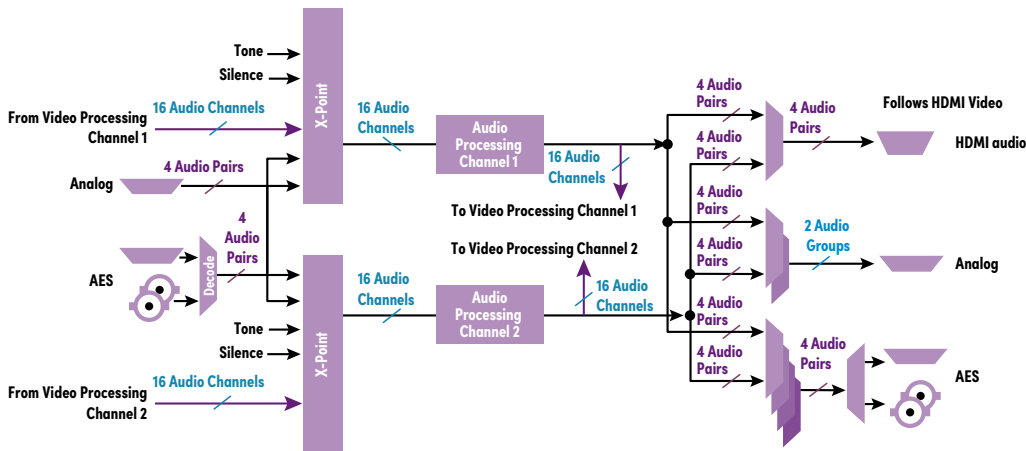

Ordering

6132100

MC2000-CT2 Dual channel motion compensated frame-rate converter and adaptive format converter. Including frame synchronization, ARC control, noise reduction, side-bar keying, logo insertion, CC, WST and timecode handling, picture enhancement tools, 16-channel audio processing inc gain, delay & shuffling. SD, HD and 3G-SDI (BNC or fiber), CVBS, GPI, AES and analog audio I/O. HDMI monitor output & dual PSUs.

6131100

MC1000-CT1 Single channel motion compensated frame-rate converter and adaptive format converter. Including frame synchronization, ARC control, noise reduction, side-bar keying, logo insertion, CC, WST and timecode handling, picture enhancement tools, 16 channel audio processing inc gain, delay & shuffling. SD, HD and 3G-SDI (BNC or Fiber), CVBS, GPI, AES and analog audio I/O. HDMI monitor output & Dual PSUs.

Fiber SFP Options for Fiber – A&B

FC1-13TR Transceiver 1310 nm/Rx
 FC1-13T1 Single 1310 nm Tx
 FC1-13T2 Dual 1310 nm Tx
 FC1-R1 Single Rx
 FC1-R2 Dual Rx
 FC1-HDBT2 HD-BNC Dual Tx
 FC1-HDBR2 HD-BNC Dual Rx

Note: Fiber SFP type must be ordered in addition to the unit.

Specifications

Signal Inputs

Serial digital 4x 75Ω SD/HD/3G serial digital with embedded audio

Input standards:

- 3 Gb/s SD-SDI, SMPTE ST 425 level A, level B
- 1.5 Gb/s HD-SDI SMPTE ST 292/SMPTE ST 299
- 270 Mb/s SD-SDI SMPTE ST 259

Composite PAL, NTSC, NTSC-J, PAL-M, PAL-N, N4.4, SECAM

12-bit ADCs

Analog component YC

Reference: 1 x loop-through HDTV Tri-sync/SD Bi-sync (blackburst): SMPTE ST 240/SMPTE ST 274

Audio AES:

- 4x balanced AES inputs – via 25-way D-type
- 4x unbalanced AES inputs – via 4x BNC

Audio analog: 4x stereo analog inputs via 25-way D-type

Signal Outputs

Serial digital 4x 75Ω SD/HD/3G serial digital with embedded audio

Output standards:

- 3 Gb/s HD-SDI, SMPTE ST 425 level A, level B
- 1.5 Gb/s HD-SDI SMPTE ST 292/SMPTE ST 299
- 270 Mb/s SD-SDI SMPTE ST 259

Composite PAL, NTSC, NTSC-J, PAL-M, PAL-N, 12-bit DACs

Analog component YC

Audio AES:

- 4x balanced AES outputs – via 25-way D-type
- 4x unbalanced AES outputs – via 4x BNC

Audio analog: 2x stereo analog outputs via 25-way D-type

Input Standards

(auto detect) 525, 625

720 50/59.94/60p

1080 50/59.94/60i

1080 50/59.94/60p (Levels A and B)

720/1080 23.98/24/25/29/30p

1080 23.98/24/25/29PsF

Output Standards

525, 625

720 50/59.94/60p

1080 50/59.94/60i

1080 50/59.94/60p (Levels A and B)

720/1080 23.98/24/25/29/30p

1080 23.98/24/25/29PsF

Conversion Functions

Modes: SD/HD/3G Linear/motion compensated frame rate

Conversion processing:

Still process: Detects still images and applies an aperture with full (progressive) vertical frequency response

Enhanced still: Adds field motion detection to still process. Prevents artifacts on moving repetitive patterns

Manual or Automatic ARC

AFD (SMPTE ST 2016), VI (RP186), WSS (L23)

SD input format: Normal 4:3, Anamorphic 16:9, Letterbox 14:9, Letterbox 16:9

SD output format: Normal 4:3, Anamorphic 16:9, Letterbox 14:9, Letterbox 16:9

Auto zoom: On/Off

Manual zoom: Zoom ±20%

Safe area marker: Off, 16:9, 4:3

Manual controls: size, aspect, pan, tilt

Wide range of ARC presets including 702 sample line mode

Audio Functions

Analog Audio:

Four pairs of analog inputs are individually available to any or all processing channels

Two groups (2 pairs) of analog output are separately assignable to any processing channel

Headroom +24 dBu; balanced connection

AES Audio:

Four AES audio inputs are individually available to any or all processing channels

Four AES audio outputs (48 kHz) are separately assignable to any processing channel

AES input is auto-detected as PCM (32-96 kHz) or non-PCM (48 kHz locked to relevant video input)

Embedded Audio:

Each processing channel includes 16-channel embedded audio processing

PCM audio processing includes channel level gain and delay compensation, as well as channel level routing/shuffle with audio phase inversion

Non-PCM processing features pair level routing and delay compensation

Metadata

Closed caption CEA608 <> CEA708

Timecode conversions

WST/SMPTE RDD08/SMPTE ST 2031 conversion

Enhancement

Advanced Horizontal Enhancement:

Frequency band selection (Low, Med, High)

4 preset enhancement levels (Soft 2, Soft 1, Normal, Sharp 1, Sharp 2)

Custom H Gain and H Noise rejection levels

Advanced Vertical Enhancement:

Frequency band selection (Low, Med, High)

5 preset enhancement levels (Soft, Normal, Sharp 1, Sharp 2, Sharp 3)

Horizontal Aperture:

5 preset H sharpness levels (Low 2, Low 1, Normal, High 1, High 2)

5 preset H detail levels (Soft 2, Soft 1, Normal, Sharp 1, Sharp 2)

Noise reduction: Spatial, recursive

Y/C alignment: Corrects for up-stream luma chroma displacement

System

Pattern Off, Black, Ramp, Bars

Proc amp:

Black Level: +100 to -100 mV (0) in 0.8 mV steps

Contrast: -6 dB to +6 dB (0) in 0.2 dB steps

Saturation: -6 dB to +6 dB (0) in 0.2 dB steps

Y Gamma: 0.4 to 1.7 (1) in 0.1 steps

Freeze: On/Off

Genlock: Reference lock, Input lock (same format), Follow input (same frame rate), Free run

Memories: 16 user memories

Legalizer

EDH support

Communications

Remote control via web interface, GV Orbit and SNMP

Power (Primary and Secondary)

Input voltage range: 100 – 240 VAC, 50/60 Hz 1.5A (max.) via three-pin IEC power socket

Mechanical

Temperature range: 0 to 45° C (32° to 113° F) operating

Cooling: Internal fan, side venting

Weight: Approximately 4.25 kg (9.4 lbs.)

Case type: 1 RU, rack mounting

Dimensions: 44 x 430 x 400 mm (1.7 x 16.9 x 15.7 in.) (HxWxD)

Headphones socket with volume control

GPIO: 8 available

Throughput Delay

Video processing delay:

– **Field = 16.7 or 20 ms**

– **Frame = 33.3 or 40 ms**

With scaling active in same frame rate:

– Ref lock/Free run – Between 3 and 5 fields + ~200 μs

– Input lock (SDI) – 3 fields + 1ms

With same standard in & out and sync mode = Enabled:

– Ref lock/Free run – Between ~200 μs and 1 frame + ~200 μs

– Input lock (SDI) – ~1 ms

Frame-rate conversion: Any lock mode – 110 ms typical

Audio processing delay: (Audio delay = 0 ms)

With scaling active in same frame rate:

– Ref lock/Free run – 1.5 frames

– Input lock – 1 frame + 1 ms

With same standard in & out and sync mode = Enabled:

– Ref lock Free run – 0.5 frames

– Input lock – ~3 ms

Frame-rate conversion: Any lock mode – 110 ms typical

LC2000 & LC4000



Motion Adaptive Frame-rate Converter

The LC2000 and LC4000 are highly cost-effective, linear motion adaptive frame-rate converters.

Key Features

- Linear motion adaptive SD/HD/3G frame-rate conversion
- Independent dual-channel (LC2000) and quad-channel conversion (LC4000)
- SD/HD/3G up/down/crossconversion
- Flexible video and audio I/O configuration
- 16-channel embedded audio processing for each video channel
- Continuous output when input standard switches
- HDMI monitor output
- Dual PSU as standard
- Relay bypass on primary SDI inputs
- Automatic aspect ratio conversion (AFD, VI, L23)
- Powerful picture enhancement tools
- Front panel and remote control via web interface and GV Orbit
- Closed caption and timecode handling
- Synchronization
- User chosen line for SMPTE ST 2016
- GPI support
- Front panel control lock
- Caption generator
- Logo inserter
- Sidebar keyer
- Clean cut
- Composite input/output
- Fiber input/output

Applications

- High-density international program distribution
- Low-cost frame-rate conversion
- International TV and video backup channels

LC2000 Video Processing

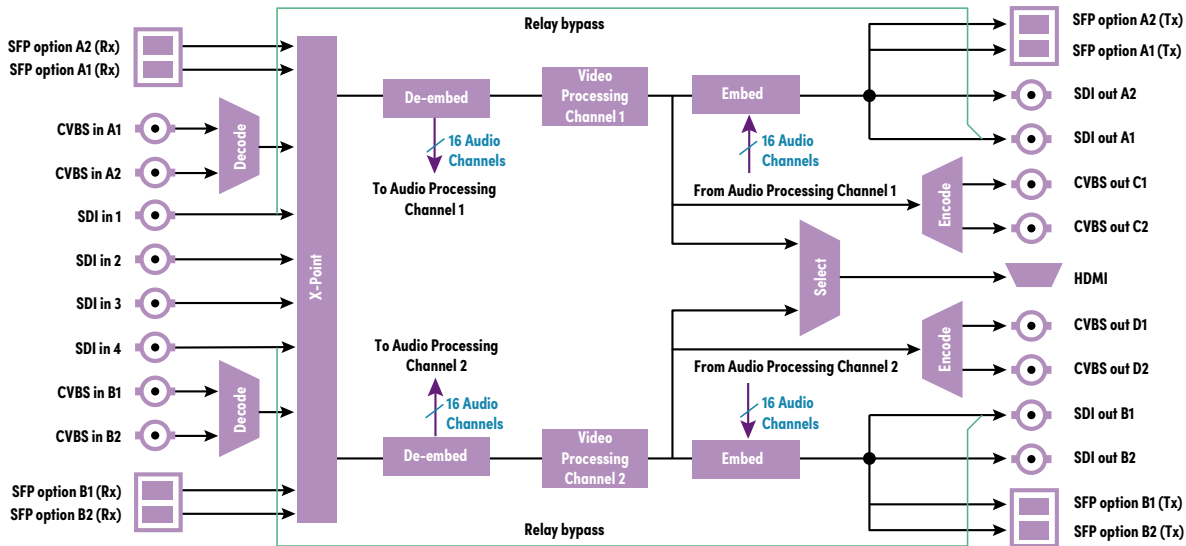

LC2000 Audio Processing

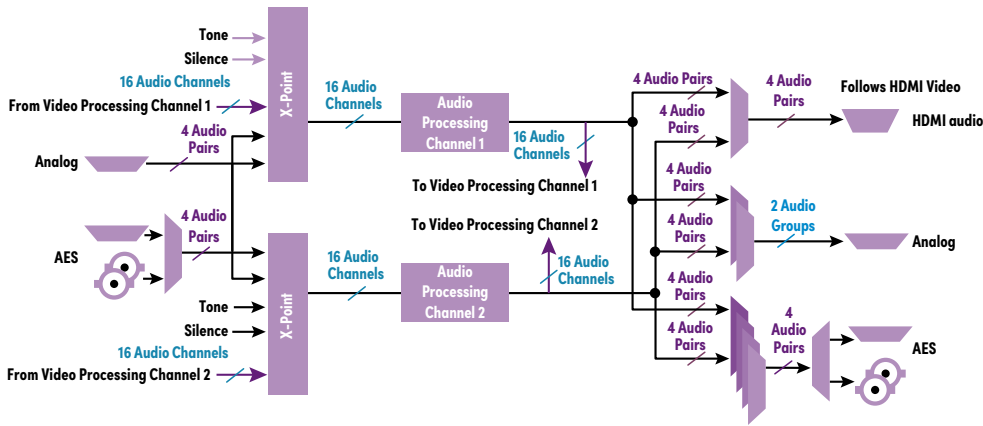

LC4000 Video Processing

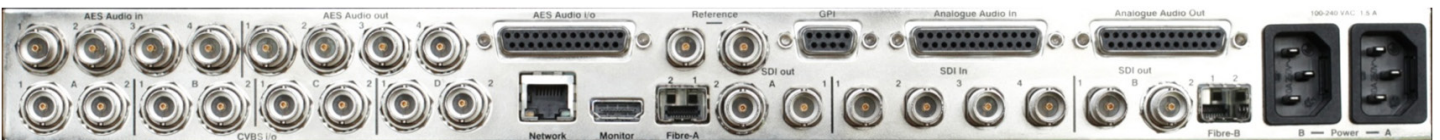
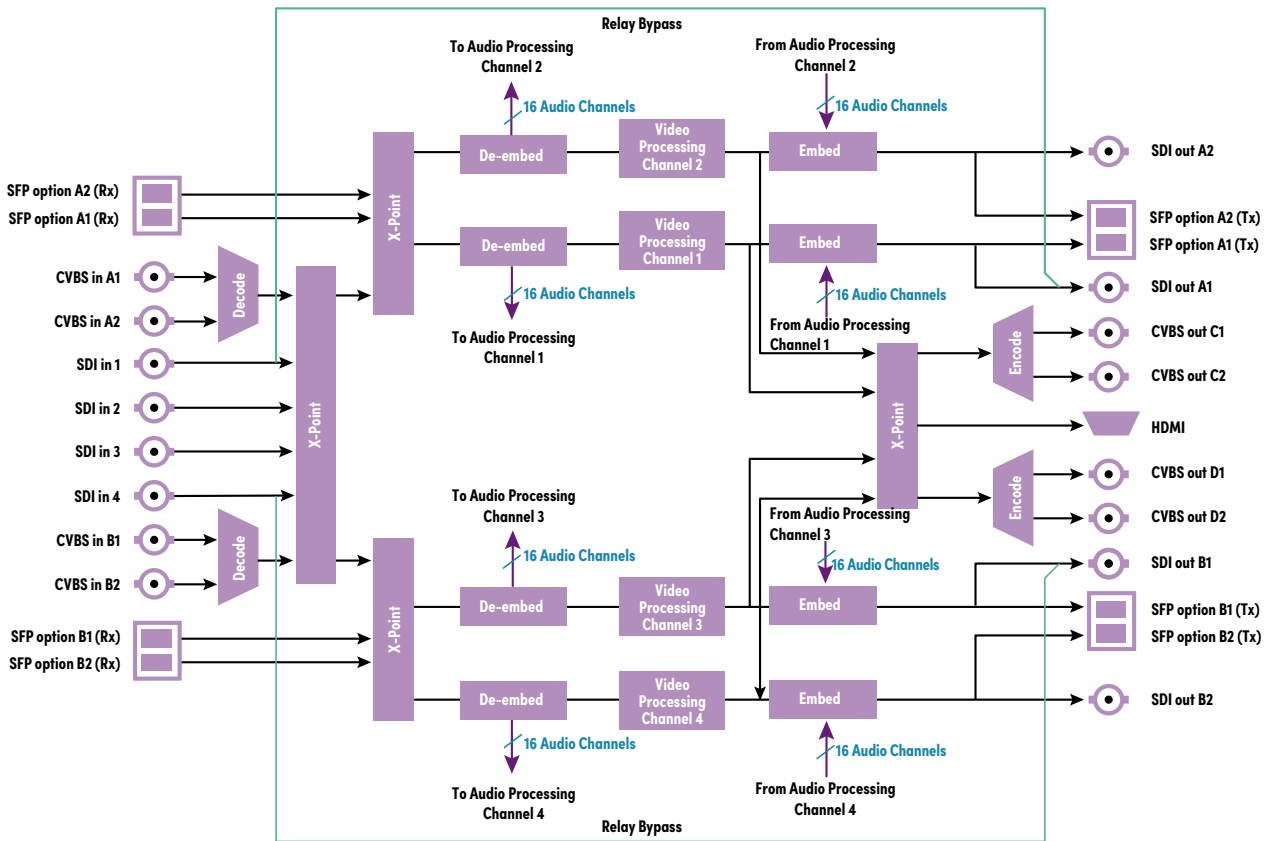

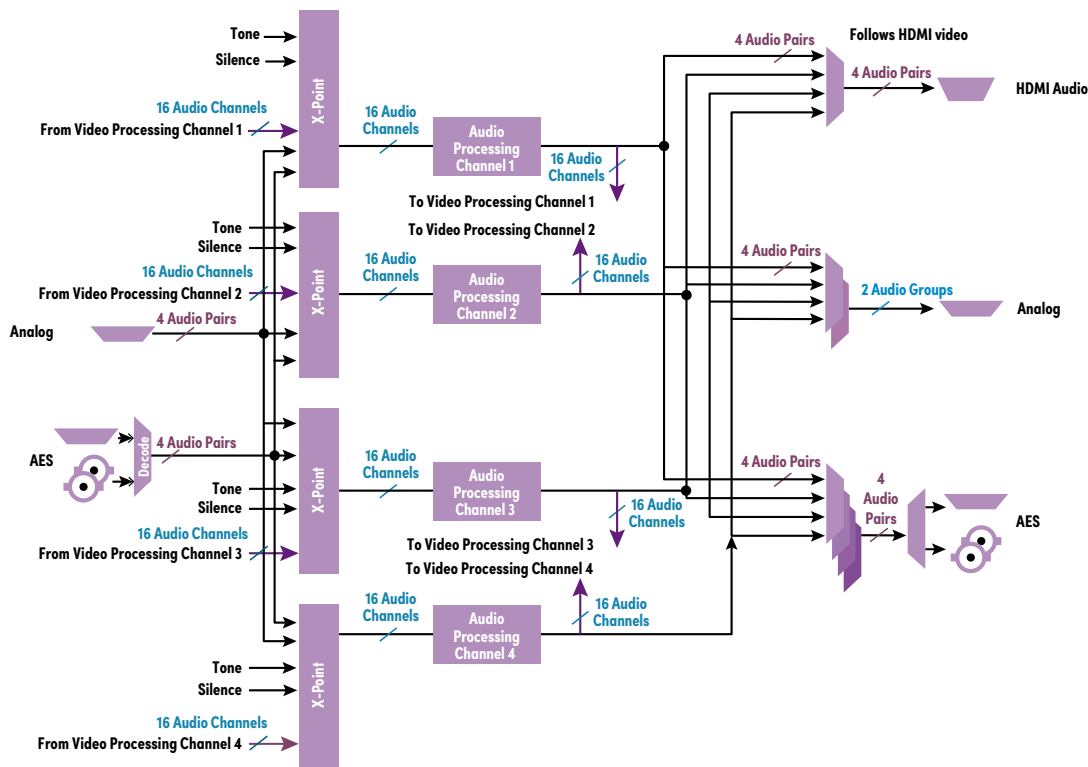

Specifications

Signal Inputs

Serial digital 4x 75Ω SD/HD/3G serial digital with embedded audio

Input standards:

- 3 Gb/s SD-SDI, SMPTE ST 425 level A, level B
- 1.5 Gb/s HD-SDI SMPTE ST 292/SMPTE ST 299
- 270 Mb/s SD-SDI SMPTE ST 259

Composite PAL, NTSC, NTSC-J, PAL-M, PAL-N, N4.4, SECAM

12-bit ADCs

Analog component YC

Reference: 1x loop-through HDTV Tri-sync/SD Bi-sync (blackburst) SMPTE ST 240/SMPTE ST 274

Audio AES:

- 4x balanced AES inputs – via 25-way D-type
- 4x unbalanced AES inputs – via 4x BNC

Audio analog: 4x stereo analog inputs via 25-way D-type

Signal Outputs

Serial digital 4x 75Ω SD/HD/3G serial digital with embedded audio

Output standards:

- 3 Gb/s HD-SDI, SMPTE ST 425 level A, level B
- 1.5 Gb/s HD-SDI SMPTE ST 292/SMPTE ST 299
- 270 Mb/s SD-SDI SMPTE ST 259

Composite PAL, NTSC, NTSC-J, PAL-M, PAL-N

12-bit DACs

Analog component YC

Audio AES:

- 4x balanced AES outputs – via 25-way D-type
- 4x unbalanced AES outputs – via 4x BNC

Audio analog: 2x stereo analog outputs via 25-way D-type

Input Standards

(auto detect) 525, 625

720 50/59.94/60p

1080 50/59.94/60i

1080 50/59.94/60p (Levels A and B)

720/1080 23.98/24/25/29/30p

1080 23.98/24/25/29PsF

Output Standards

525, 625

720 50/59.94/60p

1080 50/59.94/60i

1080 50/59.94/60p (Levels A and B)

720/1080 23.98/24/25/29/30p

1080 23.98/24/25/29PsF

Conversion Functions

Modes:

SD/HD/3G linear frame rate

Up/down/crossconversion

Frame Synchronizer

Conversion: Up/down/crossconversion

Manual or Automatic ARC

AFD (SMPTE ST 2016), VI (RP186), WSS (L23)

SD input format: Normal 4:3, Anamorphic 16:9, Letterbox 14:9, Letterbox 16:9

SD output format: Normal 4:3, Anamorphic 16:9, Letterbox 14:9, Letterbox 16:9

Auto zoom: On/Off

Manual zoom: Zoom ±20%

Safe area marker: Off, 16:9, 4:3

Manual controls: Size, aspect, pan, tilt

Wide range of ARC presets including 702 sample line mode

Specifications (cont.)

Audio Functions

Analog Audio:

Four pairs of analog inputs are individually available to any or all processing channels

Two groups (2 pairs) of analog output are separately assignable to any processing channel

Headroom +24 dBu; balanced connection

AES Audio:

Four AES audio inputs are individually available to any or all processing channels

Four AES audio outputs (48 kHz) are separately assignable to any processing channel

AES input is auto-detected as PCM (32-96 kHz) or non-PCM (48 kHz locked to relevant video input)

Embedded Audio:

Each processing channel includes 16-channel embedded audio processing

PCM audio processing includes channel level gain and delay compensation, as well as channel level routing/shuffle with audio phase inversion

Non-PCM processing features pair level routing and delay compensation

Metadata

Closed caption CEA608 <> CEA708

Timecode conversions

WST/SMPTE RDD08/SMPTE ST 2031 conversion

Enhancement

Advanced Horizontal Enhancement:

Frequency band selection (Low, Med, High)

4 preset enhancement levels (Low, Med, High, Super)

Custom H Gain and H Noise rejection levels

Advanced Vertical Enhancement:

Frequency band selection (Low, Med, High)

5 preset enhancement levels (Soft 2, Soft 1, Normal, Sharp 1, Sharp 2)

Horizontal Aperture:

5 preset H sharpness levels (Low 2, Low 1, Normal, High 1, High 2)

5 preset H detail levels (Soft 2, Soft 1, Normal, Sharp 1, Sharp 2)

Noise reduction: Spatial, recursive

Y/C alignment: Corrects for upstream luma-chroma displacement

System

Pattern Off, Black, Ramp, Bars

Proc amp:

Black Level: +100 to -100 mV (0) in 0.8 mV steps

Contrast: -6 dB to +6 dB (0) in 0.2 dB steps

Saturation: -6 dB to +6 dB (0) in 0.2 dB steps

Y Gamma: 0.4 to 1.7 (1) in 0.1 steps

Freeze: On/Off

Genlock: Reference lock, Input lock (same format), Follow input (same frame rate), Free run

Memories: 16 user memories

Legalizer

EDH support

Communications

Remote control via web interface, GV Orbit and SNMP

Power (Primary and Secondary)

Input voltage range 100 – 240 VAC, 50/60 Hz 1.5A (max.) via three-pin IEC power socket

Mechanical

Temperature range: 0 to 45° C (32° to 113° F) operating

Cooling: Internal fan, side venting

Weight: Approximately 4.25 kg (9.4 lbs.)

Case type: 1 RU, rack mounting

Dimensions: 44 x 430 x 400 mm (1.7 x 16.9 x 15.7 in.) (HxWxD)

Headphones socket with volume control

GPIO: 8 available

Throughput Delay

Video processing delay:

– **Field = 16.7 or 20 ms**

– **Frame = 33.3 or 40 ms**

With scaling active in same frame rate:

– Ref lock/Free run – between 3 and 5 fields + ~200 µs

– Input lock (SDI) – 3 fields + 1 ms

With same standard in & out and Sync mode = Enabled:

– Ref lock/Free run – between ~200 µs and 1 frame + ~200 µs

– Input lock (SDI) – ~1 ms

Frame-rate conversion:

– Any lock mode – 110 ms typical

Audio processing delay (Audio delay = 0 ms):

With scaling active in same frame rate:

– Ref lock/Free run – 1.5 frames

– Input lock – 1 frame + 1 ms

With same standard in & out and sync mode = Enabled:

– Ref lock/Free run – 0.5 frames

– Input lock – ~3 ms

Frame-rate conversion:

– Any lock mode – 110 ms typical

Ordering

6122110

LC2000-CT2 Dual channel video & audio processing unit, including frame-rate/format conversion, frame synchronization, ARC control, noise reduction, side-bar keying, logo insertion, CC, WST and timecode handling, picture enhancement tools, 16 channel audio processing including gain, delay & shuffling. SDI (BNC or fiber), CVBS, GPI, AES and analog audio I/O. HDMI monitor output & dual PSUs.

6124110

LC4000-CT2 Quad channel video & audio processing unit, including frame-rate/format conversion, frame synchronization, ARC control, noise reduction, side-bar keying, logo insertion, CC, WST and timecode handling, picture enhancement tools, 16 channel audio processing including gain, delay & shuffling. SDI (BNC or Fiber), CVBS for 2 channels, GPI, AES and analog audio I/O. HDMI monitor output & dual PSUs.

Fiber SFP Options for Fiber – A&B

FC1-13TR Transceiver 1310 nm/Rx

FC1-13T1 Single 1310 nm Tx

FC1-13T2 Dual 1310 nm Tx

FC1-R1 Single Rx

FC1-R2 Dual Rx

FC1-HDBT2 HD-BNC Dual Tx

FC1-HDBR2 HD-BNC Dual Rx

Note: Fiber SFP type must be ordered in addition to the unit.

SV2000 & SV4000



Up/down/crossconverters and Frame Sync

SV2000 and SV4000 are low-cost, high-density up/down/crossconverters able to handle a wide range of video and audio processing and synchronization tasks.

Key Features

- SD/HD/3G up/down/crossconversion
- Independent dual channel (SV2000) and quad channel conversion (SV4000)
- Frame synchronization
- Flexible video and audio I/O configuration
16-channel embedded audio processing for each video channel
- Continuous output when input standard switches
- HDMI monitor output
- Dual PSU as standard
- Relay bypass on primary SDI inputs
- Automatic aspect ratio conversion (AFD, VI, L23)
- Powerful picture enhancement tools
- User friendly front panel as well as remote control via web interface and GV Orbit
- Closed caption and timecode handling
- User chosen line for SMPTE ST 2016
- GPI support
- Front panel control lock
- Caption generator
- Logo inserter
- Sidebar keyer
- Clean cut
- Composite input/output

Optional Features

- Fiber input/output

Applications

- Integration of SD programming into HD schedules
- Supporting legacy SD channels with HD produced content
- Future-proofing investments up to 1080p 3 Gb/s

SV2000 Video Processing

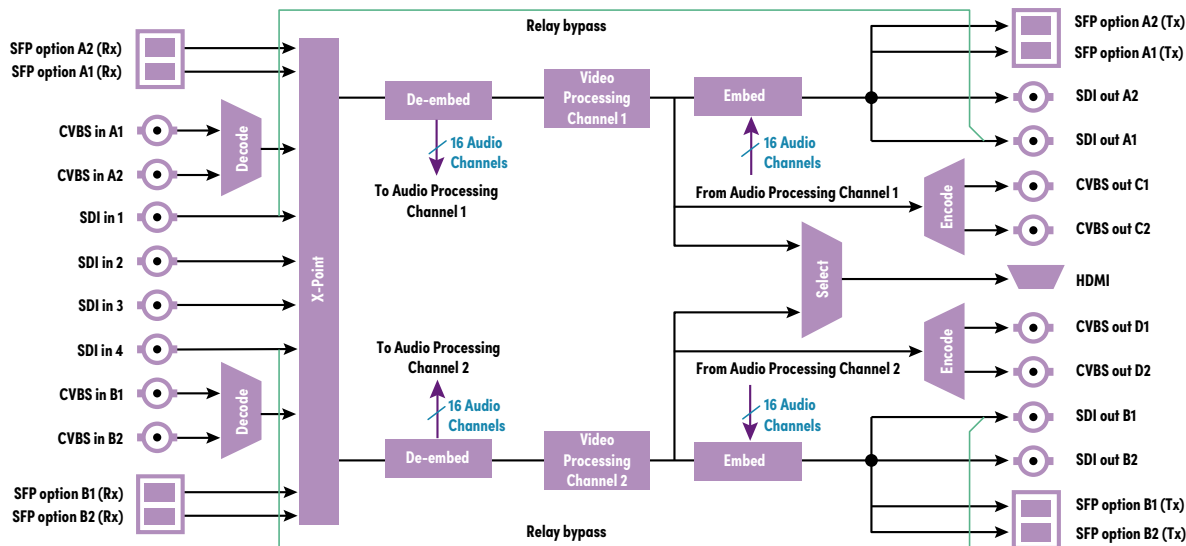

SV2000 Audio Processing

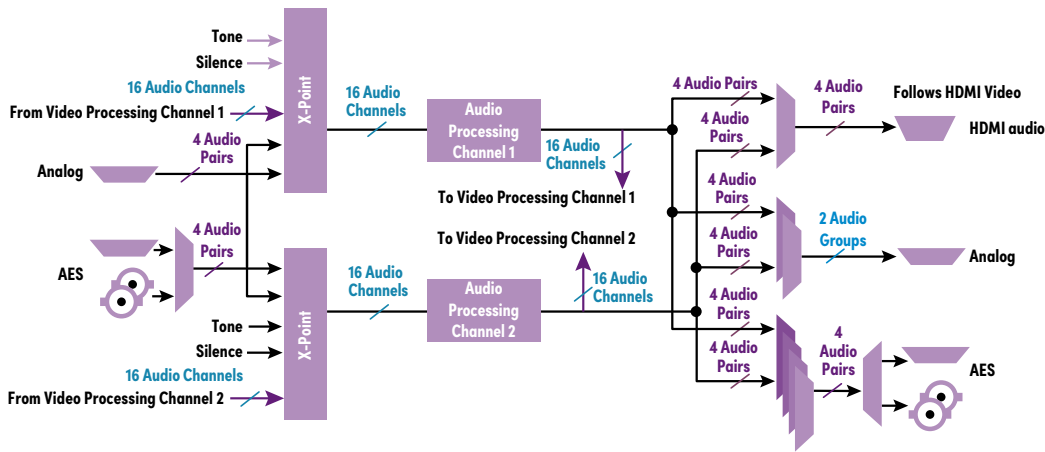

SV4000 Video Processing

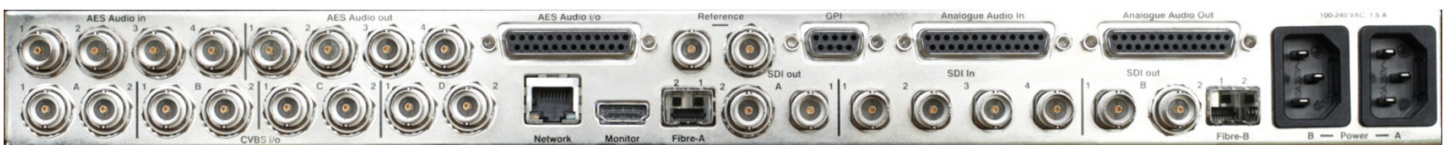
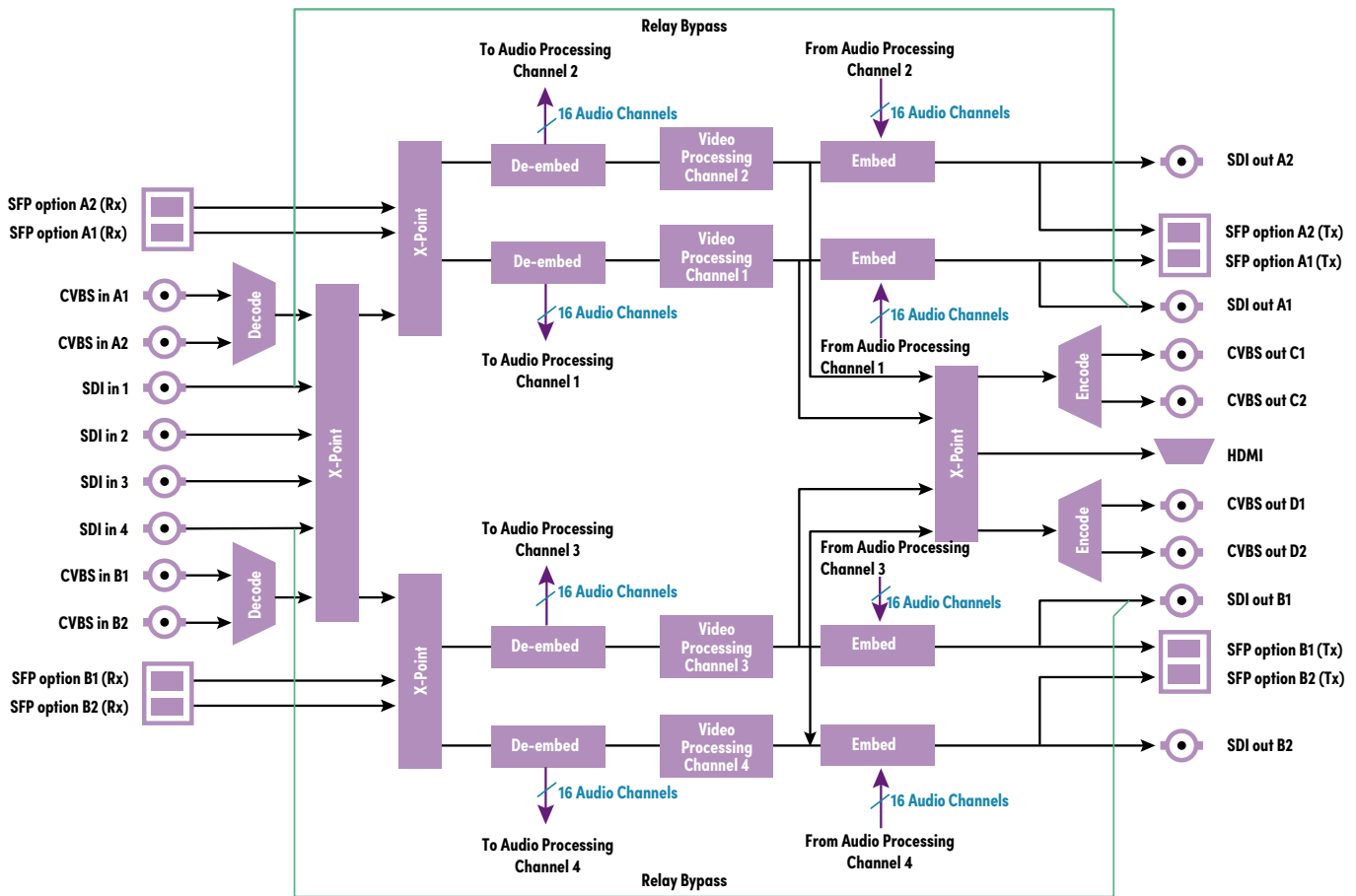

SV2000 & SV4000 rear panel view.

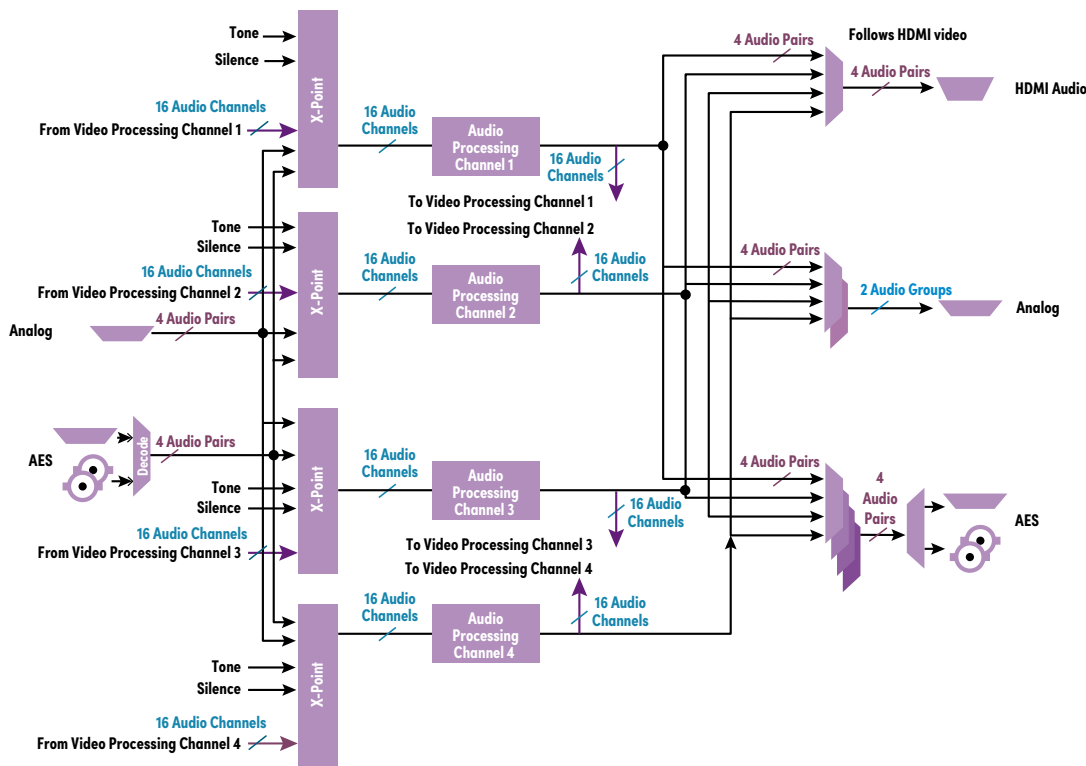

Specifications

Signal Inputs

Serial digital 4x 75Ω SD/HD/3G serial digital with embedded audio

Input standards:

- 3 Gb/s SD-SDI, SMPTE ST 425 level A, level B
- 1.5 Gb/s HD-SDI SMPTE ST 292/SMPTE ST 299
- 270 Mb/s SD-SDI SMPTE ST 259

Composite PAL, NTSC, NTSC-J, PAL-M, PAL-N, N4.4, SECAM

12-bit ADCs

Analog component YC

Reference: 1x loop-through HDTV Tri-sync/SD Bi-sync (blackburst) SMPTE ST 240/SMPTE ST 274

Audio AES:

- 4x balanced AES inputs – via 25-way D-type
- 4x unbalanced AES inputs – via 4x BNC

Audio analog: 4x stereo analog inputs via 25-way D-type

Signal Outputs

Serial digital 4x 75Ω SD/HD/3G serial digital with embedded audio

Output standards:

- 3 Gb/s HD-SDI, SMPTE ST 425 level A, level B
- 1.5 Gb/s HD-SDI SMPTE ST 292/SMPTE ST 299
- 270 Mb/s SD-SDI SMPTE ST 259

Composite PAL, NTSC, NTSC-J, PAL-M, PAL-N

12-bit DACs

Analog component YC

Audio AES:

- 4x balanced AES outputs – via 25-way D-type
- 4x unbalanced AES outputs – via 4x BNC

Audio analog: 2x stereo analog outputs via 25-way D-type

Input Standards

(auto detect) 525, 625

- 720 50/59.94/60p
- 1080 50/59.94/60i
- 1080 50/59.94/60p (Levels A and B)
- 720/1080 23.98/24/25/29/30p
- 1080 23.98/24/25/29PsF

Output Standards

- 525, 625
- 720 50/59.94/60p
- 1080 50/59.94/60i
- 1080 50/59.94/60p (Levels A and B)
- 720/1080 23.98/24/25/29/30p
- 1080 23.98/24/25/29PsF

Conversion Functions

Modes:

- SD/HD/3G up/down/crossconversion at the same frame rate
- Frame synchronizer

Manual or Automatic ARC

AFD (SMPTE ST 2016), VI (RP186), WSS (L23)

SD input format: Normal 4:3, Anamorphic 16:9, Letterbox 14:9, Letterbox 16:9

SD output format: Normal 4:3, Anamorphic 16:9, Letterbox 14:9, Letterbox 16:9

Auto zoom: On/Off

Manual zoom: Zoom ±20%

Safe area marker: Off, 16:9, 4:3

Manual controls: size, aspect, pan, tilt

Wide range of ARC presets including 702 sample line mode

Audio Functions

Analog Audio:

- Four pairs of analog inputs are individually available to any or all processing channels
- Two groups (2 pairs) of analog output are separately assignable to any processing channel
- Headroom +24 dBu; balanced connection

AES Audio:

- Four AES audio inputs are individually available to any or all processing channels
- Four AES audio outputs (48 kHz) are separately assignable to any processing channel
- AES input is auto-detected as PCM (32-96 kHz) or non-PCM (48 kHz locked to relevant video input)

Specifications (cont.)

Embedded Audio:

- Each processing channel includes 16-channel embedded audio processing
- PCM audio processing includes channel level gain and delay compensation, as well as channel level routing/shuffle with audio phase inversion
- Non-PCM processing features pair level routing and delay compensation

Metadata

Closed caption CEA608 <> CEA708

Timecode conversions

WST/SMPTE RDD08/SMPTE ST 2031 conversion

Enhancement

Advanced Horizontal Enhancement:

- Frequency band selection (Low, Med, High)
- 4 preset enhancement levels (Low, Med, High, Super)
- Custom H Gain and H Noise rejection levels

Advanced Vertical Enhancement:

- Frequency band selection (Low, Med, High)
- 5 preset enhancement levels (Soft 2, Soft 1, Normal, Sharp 1, Sharp 2)

Horizontal Aperture:

- 5 preset H sharpness levels (Low 2, Low 1, Normal, High 1, High 2)
- 5 preset H detail levels (Soft 2, Soft 1, Normal, Sharp 1, Sharp 2)

Noise reduction: spatial, recursive

Y/C alignment: corrects for up-stream lum chroma displacement

System

Pattern Off, Black, Ramp, Bars

Proc amp:

Black Level: +100 to -100 mV (0) in 0.8 mV steps

Contrast: -6 dB to +6 dB (0) in 0.2 dB steps

Saturation: -6 dB to +6 dB (0) in 0.2 dB steps

Y Gamma: 0.4 to 1.7 (1) in 0.1 steps

Freeze: On/Off

Genlock: Reference lock, Input lock (same format), Follow input (same frame rate), Free run

Memories: 16 user memories

Legalizer

EDH support

Communications

Remote control via web interface, GV Orbit and SNMP

Power (Primary and Secondary)

Input voltage range: 100 – 240 VAC, 50/60 Hz 1.5A (max.) via three-pin IEC power socket

Mechanical

Temperature range: 0 to 45° C (32° to 113° F) operating

Cooling: Internal fan, side venting

Weight: Approximately 4.25 kg (9.4 lbs.)

Case type: 1 RU, rack mounting

Dimensions: 44 x 430 x 400 mm (1.7 x 16.9 x 15.7 in.) (HxWxD)

Headphones socket with volume control

GPIO: 8 available

Throughput Delay

Video processing delay:

– **Field = 16.7 or 20 ms**

– **Frame = 33.3 or 40 ms**

With scaling active in same frame rate:

– Ref lock/Free run – Between 3 and 5 fields + ~200 μ s

– Input lock (SDI) – 3 fields + 1ms

With same standard in & out and sync mode = Enabled:

– Ref lock/Free run – Between ~200 μ s and 1 frame + ~200 μ s

– Input lock (SDI) – ~1 ms

Frame-rate conversion: Any lock mode – 110 ms typical

Audio processing delay: (Audio delay = 0 ms)

With scaling active in same frame rate:

– Ref lock/free run – 1.5 frames

– Input lock – 1 frame + 1 ms

With same standard in & out and sync mode = Enabled:

– Ref lock/free run – 0.5 frames

– Input lock – ~3 ms

Frame-rate conversion: Any lock mode – 110 ms typical

Ordering

6112110

SV2000-CT2 Dual channel video & audio processing unit, including format conversion, frame synchronization, ARC control, noise reduction, side-bar keying, logo insertion, CC, WST and timecode handling, picture enhancement tools, 16-channel audio processing including gain, delay & shuffling. SDI (BNC or fiber), CVBS, GPI, AES and analog audio I/O. HDMI monitor output & dual PSUs.

6114110

SV4000-CT2 Quad channel video & audio processing unit, including format conversion, frame synchronization, ARC control, noise reduction, side-bar keying, logo insertion, CC, WST and timecode handling, picture enhancement tools, 16-channel audio processing including gain, delay & shuffling. SDI (BNC or fiber), CVBS for 2 channels, GPI, AES and analog audio I/O. HDMI monitor output & dual PSUs.

Fiber SFP Options for Fiber – A&B

FC1-13TR

Transceiver 1310 nm/Rx

FC1-13T1

Single 1310 nm Tx

FC1-13T2

Dual 1310 nm Tx

FC1-R1

Single Rx

FC1-R2

Dual Rx

FC1-HDBT2

HD-BNC Dual Tx

FC1-HDBR2

HD-BNC Dual Rx

Note: Fiber SFP type must be ordered in addition to the unit.

This product may be protected by one or more patents. For further information, please visit: www.grassvalley.com/patents

DS-PUB-3-0730C-EN

Grass Valley®, GV® and the Grass Valley logo are trademarks or registered trademarks of Grass Valley USA, LLC, or its affiliated companies in the United States and other jurisdictions. Grass Valley products listed above are trademarks or registered trademarks of Grass Valley USA, LLC or its affiliated companies, and other parties may also have trademark rights in other terms used herein. Copyright © 2021-2023 Grass Valley Canada. All rights reserved. Specifications subject to change without notice.

www.grassvalley.com Join the Conversation at GrassValleyLive on [Facebook](#), [Twitter](#), [YouTube](#) and Grass Valley on [LinkedIn](#)