



Hyperion

Bringing Human Intelligence to Automated Broadcast Monitoring

Hyperion represents a new generation of television monitoring and quality control. Its sophisticated capabilities enable far more efficient and cost effective content monitoring than has ever been available to the broadcast industry.

To manage the increasing complexity of their operating environment, broadcasters now rely on automated systems for ingest, playout and scheduling. These systems enable broadcasters to do more with less while operating their plant at greater efficiency.

Unfortunately there is one critical system that has not kept pace with these advances - Quality Control.

Effective quality control in a modern broadcast facility requires intelligent monitoring of a wide range of functions. These include not only the quality of the video images from ingest to transmission, but also other critical issues such as multichannel sound, multiple language racks, accuracy of content scheduling & delivery, and management of metadata including closed captions, subtitles and content advisory ratings.

To check the system-wide accuracy of all these parameters would require a dedicated person to monitor the audio and video quality of each channel at every stage in the broadcast workflow - an expensive proposition that can be justified only for extremely high value content.

And even with dedicated human monitoring, it is still extremely difficult for a single operator to cope with QC of multiple language tracks, multi-channel audio and the ever-increasing amounts of technical and operational metadata that tie automated systems together.

To meet the QC needs of the modern broadcast infrastructure, a more intelligent, intuitive, system-wide monitoring approach is required.

Limitations of Current QC Monitoring Techniques

Most current QC monitoring systems have two main drawbacks. They are deployed only at the end of the signal flow just before transmission and they are designed primarily to detect the rare absolute technical failure rather than subtle issues which occur more commonly.

These systems are designed to monitor content immediately prior to transmission, so every failure detected has the potential to result in lost revenue for the broadcaster.

A better solution would be an intelligent system-wide QC process that monitors content quality at every stage of the broadcast workflow, from ingest to transmission. Unfortunately, current systems can make such an implementation economically prohibitive.

At the transmission monitoring site, most quality control systems let an operator monitor multiple channels simultaneously through a combination of software alarms and large displays powered by multi-viewers. These systems focus on detecting absolute presence (or failure) of signals, such as sync loss, no audio or digital freeze.

While the detection of such catastrophic signal loss has proved useful, this type of monitoring is no substitute for the kind of opinion based, subjective evaluation humans can bring to quality assessment. For example, current automated systems might give a "green light" to the multichannel audio associated with picture content regardless of whether the soundtrack is in the correct language or even relevant to the content.

Even with dedicated human monitoring, the sheer amount of information in the multichannel environment can quickly overwhelm the senses. An operator can ensure that program content is being broadcast to air, but may easily fail to catch a subtle error - such as a language requirement - that can result in loss of revenue.

As the potential loss of revenue due to content delivery failure is so high, a better method is needed to monitor and evaluate content quality.

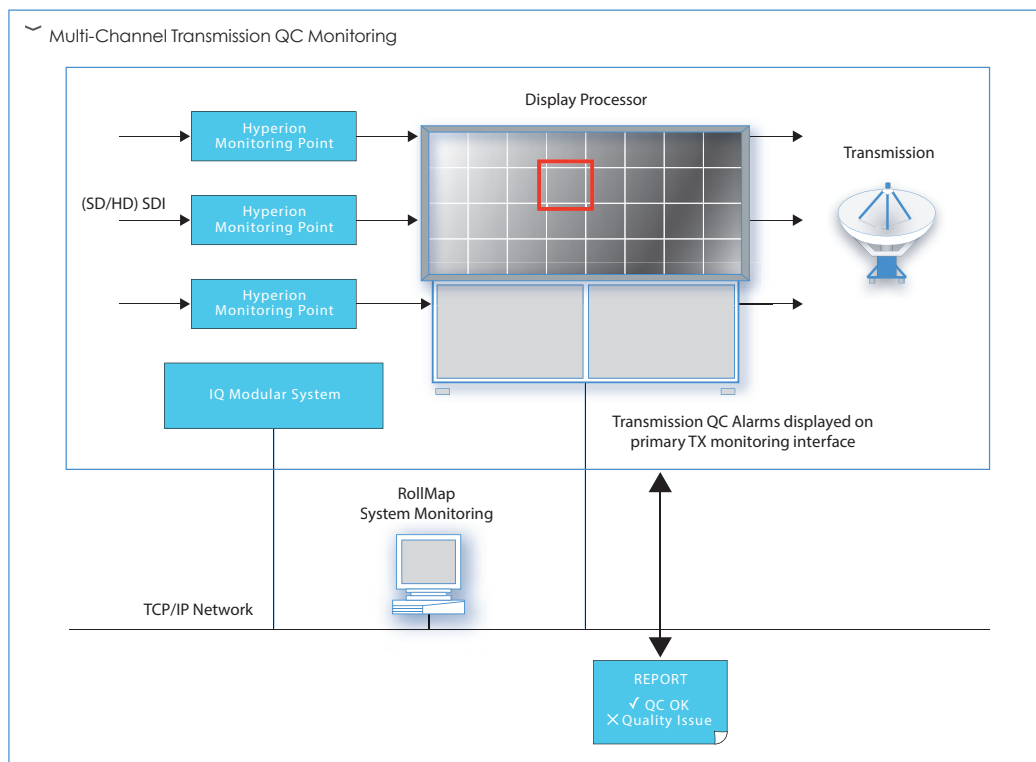

Hyperion - Automated Intelligence from Ingest to Transmission

To address this important challenge, SAM has developed Hyperion, an entirely new way to monitor the integrity of the content that passes through every stage of the broadcast infrastructure. Designed on the belief that opinion-based human intelligence is a more effective way to validate content quality than the simple monitoring of technical parameters of a video signal, Hyperion provides a set of intuitive processes that mimic the eyes and ears of a human observer. For the first time, a broadcast monitoring system evaluates the content of a television signal rather than measure the absolute technical properties of the signal carrying that content.

Hyperion is an integral part of a series of SAM products that are positioned at different points in the broadcast workflow. Therefore it can be deployed in a distributed system, making it possible for the first time to monitor content quality through the entire broadcast chain from ingest to transmission. By using the entire broadcast infrastructure to monitor quality, Hyperion can ensure that content failures never go on air.

By elevating the monitoring bar beyond a series of technical check points, the goal of Hyperion is to form an educated "opinion" as to whether content video, audio and metadata is meeting the quality standards to satisfy viewers as well as the contractual requirements necessary to generate revenue for the operator.

Fully programmable, Hyperion "opinions" can be tailored to the exact requirements of each installation. No other monitoring technology has ever even attempted to offer Hyperion's "intelligent" content evaluation.

At its core, Hyperion consists of a variety of detection algorithms that are designed to evaluate what is "normal" in various program types, according to the specifications of each customer installation. These algorithms interpret whether the content lacks value by matching its actual behavior with a pre-set profile of expected behavior.

The factors monitored in each profile, for example, may include the motion content of the video signal, the intensity of color or the amount of darkness. Unlike conventional monitoring systems, Hyperion detection works on "stillish" and not absolutely still pictures, or blackish and not absolutely black pictures. Hyperion assumes that if a picture is largely still then it is probably not valuable and probably not fulfilling its role of generating revenue. These alarms have configurable thresholds so that content does not alarm unnecessarily. Of course Hyperion also contains the technical and metadata monitoring required to validate signal integrity.

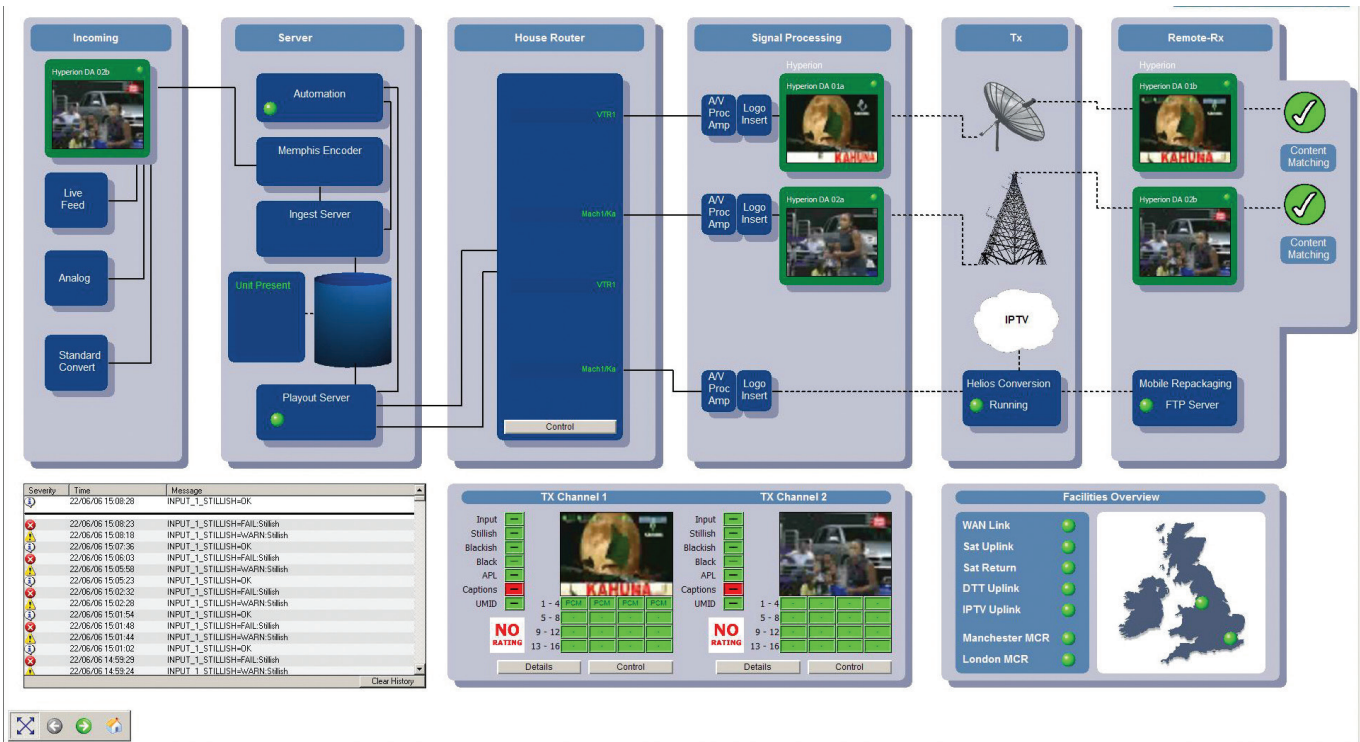

Transmission Center Main Playback Monitoring

Video “Thumbnails” and Metadata Tracking Ensure Schedule Integrity

Also included with Hyperion are tools to enable remote monitoring over IP and content identification from source to output. These tools work in conjunction with automation and scheduling systems to enable signals to be tracked and verified automatically by inserting and reading back SMPTE UMID and program ID metadata. Metadata tracking ensures that the content being broadcast is exactly what the programming schedule says it should be and can report back the total number of frames of each individual piece of content transmitted both locally and from remote locations such as head ends.

As an additional visual safeguard for remote content identification, delivery of video thumbnail images support the video, audio and metadata alarm information to provide a secondary level of confidence that content is correct at both internal and remote locations through the use of inexpensive IP network bandwidth.

Multiple Reporting Options

In the event of any problems, Hyperion can notify operators of trouble through a wide choice of alerts. It can operate through the SAM RollMap™ Infrastructure Management System and it can also integrate with a variety of third party multi-viewer systems such as the Barco Hydra and NG Display Wall processors. Also provided as standard is a full SNMP control and monitoring interface for third party integration of Hyperion enabled products.

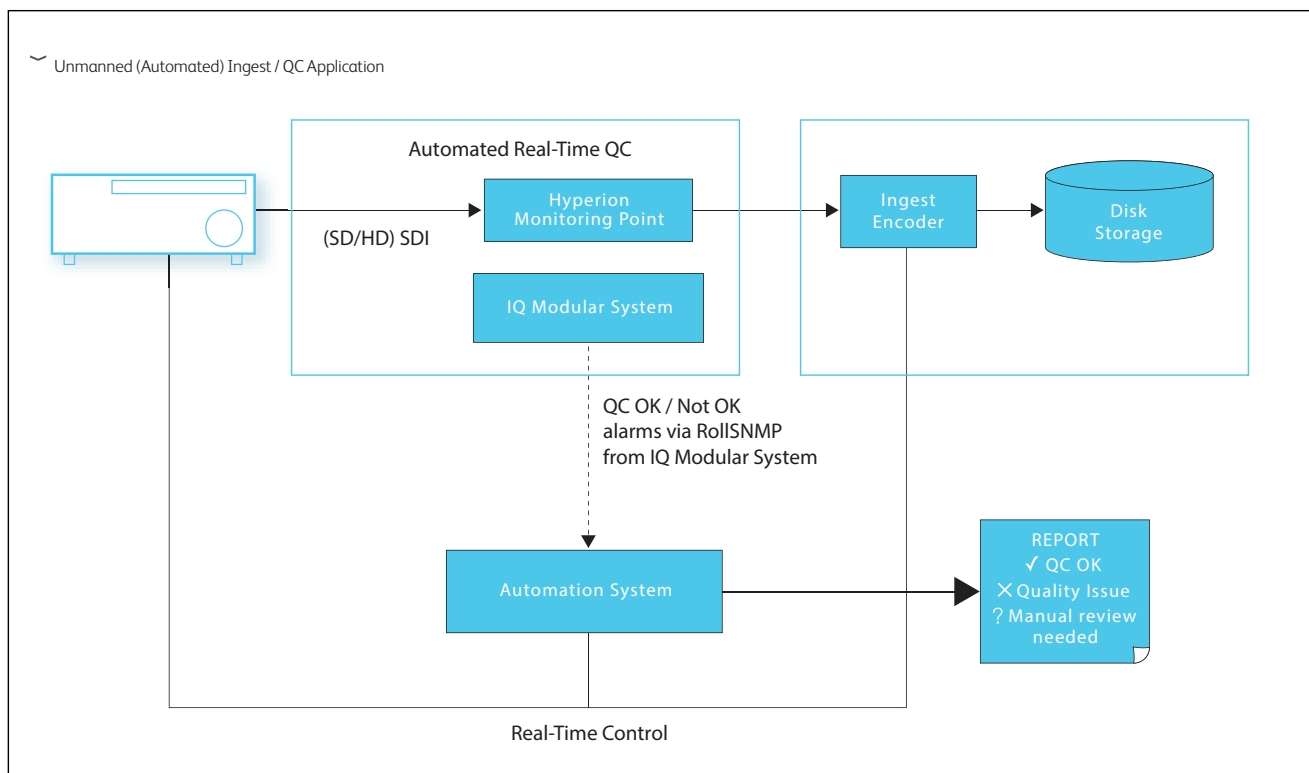

Distributed Intelligence

Because Hyperion technology is being integrated into SAM's IQ Modular™ products that process video, audio, metadata and other content, it will automatically be distributed throughout the broadcast plant where these products are installed. By using SAM infrastructure products to distribute Hyperion monitoring points in this way, customers can gain tremendous extra value throughout their operations. For example, Hyperion cards may be deployed into the ingest chain between source and Ingest Encoder to provide automated QC during the ingest process.

Transition to File-Based Operations

Not only is Hyperion a futuristic platform, it also provides a future-proof transition path for broadcast evolution. For example, it provides a metadata bridge between stream and file technologies, such as MXF, within the broadcast plant. This allows content to be tracked and monitored regardless of whether it exists in a stream or file domain. Over time, Hyperion will be implemented in all new SAM products, whether hardware or software based, thus providing a system-wide content monitoring capability with multiple monitoring points throughout the broadcast signal chain.

Hyperion represents a new generation of television monitoring and quality control. Its sophisticated capabilities enable far more efficient and cost effective content monitoring than has ever been available to the broadcast industry.