

User's Guide

3922 496 49861
status 4

LDK 4505/01
CAMERA BASE STATION FOR ETHERNET USE

Declaration of Conformity

We, Thomson Broadcast Solutions B.V., Kapittelweg 10, 4827 HG Breda, The Netherlands, declare under our sole responsibility that this product is in compliance with the following standards:

- EN60065 : Safety
- EN55103-1 : EMC (Emission)
- EN55103-2 : EMC (Immunity)

following the provisions of:

- a. the Safety Directives 73/23/EEC and 93/68/EEC
- b. the EMC Directives 89/336/EEC and 93/68/EEC

FCC Class A Statement

This product generates, uses, and can radiate radio frequency energy and if not installed and used in accordance with the instructions, may cause interference to radio communications.

It has been tested and found to comply with the limits for a class A digital device pursuant to part 15 of the FCC rules, which are designed to provide reasonable protection against such interference when operated in a commercial environment.

Operation of this product in a residential area is likely to cause interference in which case the user at his own expense will be required to take whatever measures may be required to correct the interference.

Copyright

Für diese Unterlage behalten wir uns alle Rechte vor (Gemäß DIN 34). Technische Änderungen im Zuge der Weiterentwicklung vorbehalten.

Copying of this document and giving it to others, and the use or communication of the contents thereof, are forbidden without express authority. Offenders are liable to the payment of damages. All rights are reserved in the event of the grant of a patent or the registration of a utility model or design. Liable to technical alterations in the course of further development.

Toute communication ou reproduction de ce document, toute exploitation ou communication de son contenu sont interdites, sauf autorisation expresse. Tout manquement à cette règle est illicite et expose son auteur au versement de dommages et intérêts. Tous nos droits sont réservés pour le cas de la délivrance d'un modèle d'utilité. Sous réserve de modification au cours de l'évolution technique.

Camera Base Station

User's Guide

Contents

About This Manual	ii		
Safety Instructions	1-1	Menu System	A3-1
Installation	2-1	System Menu Structure	A3-2
Unpacking/Transport/Storage	2-2	List of System Menu Functions	A3-10
Dimensions	2-3	List of Abbreviations	A3-13
Connectors and Cables	2-4	Replacements	4-1
Intercom	2-14	Introduction	4-2
Voice Mail	2-20	Power	4-2
Private Data	2-21	Opening The Base Station	4-4
Text Loop-through with multiple base stations	2-22	Replacing Dust Filters	4-5
Monitor Mode	2-23	Adjustments	5-1
MCP Available	2-24	Introduction	5-2
Specifications	2-25	Gain Adjustments Sync Encoder Board	5-3\
Operating Instructions	3-1	Diagnostics	6-1
Introduction	3-2	Diagnostic LED Indications	6-2
Front panel	3-3	Triax diagnostic indications	6-3
Set-up	3-4	Board identification	6-4
Using the Menu System	3-5	Fault finding chart	6-5

About This Manual

Service policy

The Camera Base Station is a sophisticated base station containing state-of-the-art electronic components which are designed to provide long-life operation without the need for maintenance. With this in mind, our service policy endeavours to ensure that help will be quickly on hand in the unlikely event of anything going wrong. The guiding principles of the first line maintenance philosophy are speed and cost effectiveness. First line maintenance is dedicated to keeping your base station operational, despite a fault, by module replacement and the replacement of minor mechanical parts by the user.

Purpose of this manual

The provision of correct information is the first step in ensuring the operational integrity of the base station. Information on the operation of the base station is contained in Section 3 of the manual.

This User's Guide is an integral part of the service policy. It ensures that you will be able to operate, install and set-up your base station to meet the requirements of your environment. The information on the installation of the base station is contained in Section 2 of the manual. The remaining sections of the manual provide first line service information so that suitably qualified service personnel can detect and repair faults, normally by module replacement.

Because of the complexity of some of the components, second line service can only be carried out at the specially equipped service centres and information concerning second line maintenance is not supplied in this manual.

Intended audience

The manual is intended as a guide to those with a working knowledge of camera systems and installation techniques. The first line detection and repair of faults requires a general knowledge of test and measurement techniques.

Structure of this manual

The manual is divided into six different sections:

Section 1: Safety Instructions

Outlines the safety precautions that must be taken when using the base station.

Section 2: Installation

Gives instructions on the integration of the base station into the operating environment and the customization of certain functions.

Section 3: Operating instructions

Explains how to program the menu system for your personal preferences. The menu structure and the methods of function selection are also explained. An appendix to this section lists all the menu functions.

Section 4: Replacements

Gives information on the replacement of components at first line level.

Section 5: Adjustments

Contains the adjustment procedures to be followed to obtain the best performance.

Section 6: Diagnostics

Gives a guide to diagnostic messages and procedures for fault-finding.

Identification and Status

To indicate the status of a drawing, a box with the numbers 0 to 9 is shown in the bottom-right of the drawing. The number that is crossed-out is the status number of the drawing. For example, in the illustration below, the status is 1.

0	1	2	3	4
5	6	7	8	9

A sticker is used on the units themselves to identify them and to indicate their status. For example, in the illustration below, the top line is the 12-digit number that identifies the unit type.

3922	406	88991
00121107	00	01

The first four digits of the number on the second line represent a date code (year, week); the next four digits represent the serial number for that week.

The number in the grey area indicates the status of the unit. The last two digits represent the number that will be given to the next status. However, if these two digits are contained in a box, then this is the current status. For example, in the illustration above, the current status of the unit is 01.

Section 1

Safety Instructions

This section outlines the precautions that must be taken into account when using the camera base station.

Contents

Safety Summary	1-2	Earthing	1-3
Cautions and Warnings	1-2	Mains Lead Wiring	1-3

Safety Summary

This information is intended as a guide for trained and qualified personnel who are aware of the dangers involved in handling potentially hazardous electrical/electronic equipment. It is not intended to contain a complete list of all safety precautions which should be observed by personnel in using this or other electronic equipment.

The installation, maintenance and service of this equipment involves risks both to personnel and equipment and must be performed only by qualified personnel exercising due care.

Personnel engaged in the installation, operation, maintenance or servicing of this equipment are urged to become familiar with First Aid theory and practices.

During installation and operation of this equipment, local building safety and fire protection standards must be observed.

Before connecting the equipment to the power supply of the installation, the proper functioning of the protective earth lead of the installation needs to be verified.

Whenever it is likely that safe operation is impaired, the apparatus must be made inoperative and secured against any unintended operation. The appropriate servicing authority must then be informed. For example, safety is likely to be impaired if the apparatus fails to perform the intended function or shows visible damage.

This product has been designed and tested according to EN60065.

Cautions and Warnings

When performing service, be sure to read and comply with the warning and caution notices appearing in the manuals. Warnings indicate danger that requires correct procedures or practices to prevent death or injury to personnel. Cautions indicate procedures or practices that should be followed to prevent damage or destruction to equipment or property.

WARNING

THE CURRENT AND VOLTAGES PRESENT IN THIS EQUIPMENT ARE DANGEROUS. ALL PERSONNEL MUST AT ALL TIMES FOLLOW THE SAFETY REGULATIONS.

ALWAYS DISCONNECT POWER BEFORE REMOVING COVERS OR PANELS.

ALWAYS DISCHARGE HIGH VOLTAGE POINTS BEFORE SERVICING.

NEVER MAKE INTERNAL ADJUSTMENTS, PERFORM MAINTENANCE OR SERVICE WHEN ALONE OR WHEN FATIGUED.

IN CASE OF AN EMERGENCY ENSURE THAT THE POWER IS DISCONNECTED.

ANY INTERRUPTION OF THE PROTECTION CONDUCTOR INSIDE OR OUTSIDE THE APPARATUS, OR DISCONNECTION OF THE PROTECTIVE EARTH TERMINAL, IS LIKELY TO MAKE THE APPARATUS DANGEROUS. INTENTIONAL INTERRUPTION IS PROHIBITED.

FOR SAFETY REASONS THE CPU MUST BE MOUNTED IN A 19-inch RACK WHICH HAS SAFETY COVERS ACCORDING TO IEC65.

WHEN TWO CPUs ARE MOUNTED ABOVE EACH OTHER THE MINIMUM DISTANCE BETWEEN THEM MUST BE 50MM OR THE RACK MUST BE FORCE-AIR COOLED.

USE ONLY FUSES OF THE TYPE AND RATING SPECIFIED.

CAUTION

To prevent risk of overheating, ventilate the product correctly.





Connect the product only to a power source with the specified voltage rating.

Only connect a Triax cable from the LDK 6 camera family to an LDK 6 CPU. Never connect it to any other base station.

Never connect the Triax cable from a camera to a CPU of a different family; never connect the LDK family to the TTV family.

Do not allow system ground currents to exceed 1.5A in the outer shield of the triax cable or 0.2A in other cable shields.

It is strictly prohibited to short circuit the inner and outer shields of a triax cable used to connect a camera to a base station.

Symbol	Colour	Explanation
	Red	High voltage terminal at which a voltage, with respect to an other terminal, exists or may be adjusted to 1000V or more.
	Yellow/Black	Live part.
	Yellow/Black	This marking indicates that the operator must refer to an explanation in the Instruction Manual, or that a specific component must be replaced by the component specified in the documentation for safety reasons.
	White/Black	Protective earth (ground) terminal.

Cathode ray tubes



Components marked  on the circuit diagram are critical for safety and include those specified to comply with X-ray emission standards for units using cathode ray tubes and those specified for compliance with various regulations regarding spurious radiation emission.

When servicing units that use cathode ray tubes (CRTs), the cathode ray tubes themselves, the high voltage circuits and related circuits are specifically chosen so that they comply with recognized codes pertaining to X-ray emission.

Consequently, when servicing, replace the cathode ray tubes and other parts with specified parts only. Do not attempt to modify these circuits as any unauthorized modification can increase the high voltage value and cause X-ray emission from the cathode ray tube.

Handle the cathode ray tube only when wearing shatterproof goggles and after discharging the high voltage completely.

Earthing

The rear of a CPU has two separate screw terminals for protective earth  (PE) and video earth  (VE).

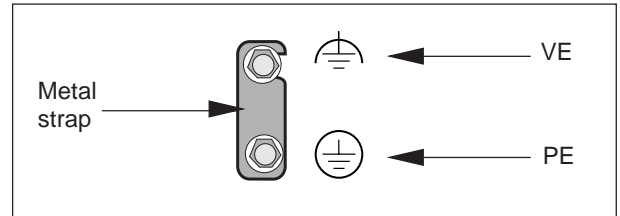

These are normally connected by a metal strap. The protective earth terminal is internally connected to the protective earth conductor of the power cable. If required, the central earth connection wire of the studio can be connected to terminal PE.

In normal circumstances the connection between the protective earth and the video earth should not be broken.

The metal strap may be removed only if the studio (or OB van) is equipped with separate protective and video earth systems. Under these circumstances the video earth terminal must be connected to the central functional earth potential (video earth) of the studio. This earth potential should have functional protective and noiseless earth (FPE) qualities as stated in the VDE regulation 0800/part2. A low impedance interconnection of both earth conductors must be provided at the central studio earthing point.

WARNING

THE UNIT MUST ALWAYS BE CONNECTED TO PROTECTIVE EARTH.

Mains Lead Wiring for UK Users

The wires in the mains lead are coloured in accordance with the following code:

GREEN AND YELLOW	-	EARTH
BLUE	-	NEUTRAL
BROWN	-	LIVE

As the colours of the wires in the mains lead of this apparatus may not correspond with the coloured markings identifying the terminals in your plug proceed as follows:

- The wire coloured GREEN AND YELLOW must be connected to the terminal on the plug marked with the letter E or by the safety earth symbol  or coloured GREEN or GREEN AND YELLOW.
- The wire coloured BROWN must be connected to the terminal marked with the letter L or coloured RED.
- The wire coloured BLUE must be connected to the terminal marked with the letter N or coloured BLACK.

Ensure that your equipment is connected correctly - if you are in any doubt consult a qualified electrician.

Section 2

Installation

This section provides information which is relevant when the base station is to be used for the first time. Packing and unpacking instructions together with information on the integration of the base station into your studio system are provided. The procedures for the customization of certain hardware functions and connector information is also provided.

Contents

Unpacking/Transport/Storage	2-2	Text Loop-through with multiple base stations	2-23
Dimensions	2-3	Monitor Mode	2-24
Connectors and Cables	2-4	Reference input and output	2-26
Intercom	2-14	MCP Available	2-27
Voice Mail	2-21	Specifications	2-28
Private Data	2-22		

Unpacking/Transport/Storage

Unpacking

Inspect the shipping container for evidence of damage immediately after receipt. If the shipping container or cushioning material is damaged, it should be kept until the contents of the shipment have been checked for completeness and the units have been checked mechanically and electrically.

The shipping container should be placed upright and opened from the top.

Remove the cushioning material and lift out the contents.

The contents of the shipment should be checked against the packing list. If the contents are incomplete, if there is mechanical damage or defect, or if the units do not perform correctly when unpacked, notify your sales representative or service centre within eight days. If the shipping container shows signs of damage or stress, notify the carrier as well.

Transport

If a unit is being returned for servicing, try to use the containers and materials of the original packaging. Attach a tag indicating the type of service required, return address, model number, full serial number and the return number which will be supplied by your service centre.

If the original packing can no longer be used, the following general instructions should be used for repacking with commercially available materials:

- a. Wrap unit in heavy paper or plastic.
- b. Use strong shipping container.
- c. Use a layer of shock-absorbing material around all sides of the unit to provide firm cushioning and prevent movement inside container.
- d. Seal shipping container securely.
- e. Mark shipping container FRAGILE to ensure careful handling.

Storage

The unit may be stored (non-operating condition) in environments within the following limits:

Temperature:	-40°C to +70°C
Humidity:	Max. 90% (non condensing)
Altitude:	max. 50.0000 feet

When stored, the unit should be protected from temperature extremes which may cause condensation, and should also be protected from high levels of dust.

Dimensions

Dimensions:

Width: 438 mm
Height: 88 mm
Depth: 510 mm max. (excluding triax connector + cable)

Weight: approx. 17kg.

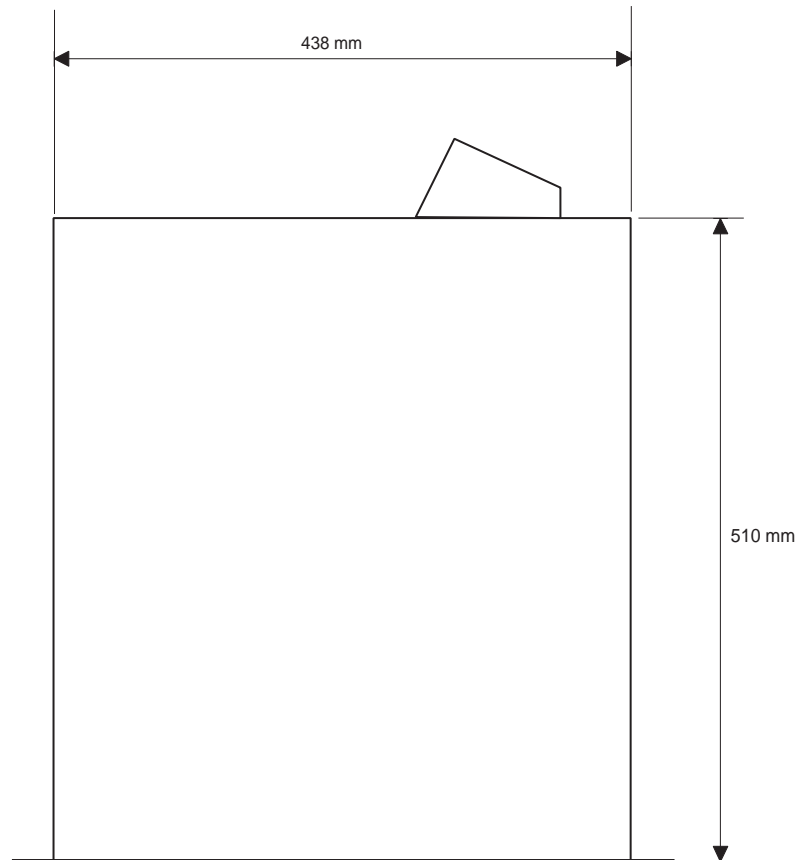
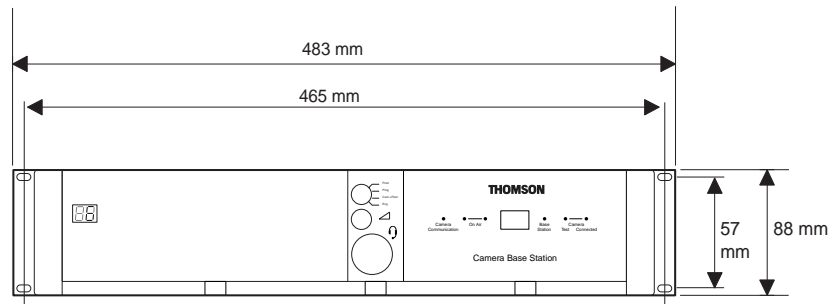

Connectors and Cables

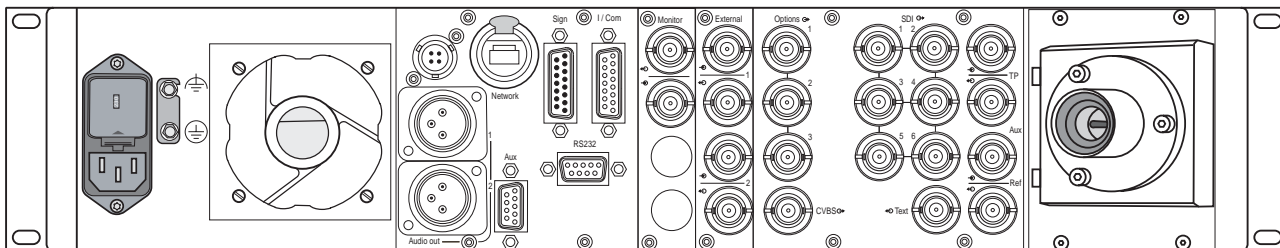

Triax connector orientation

The triax connector can be mounted to suit your cable run.

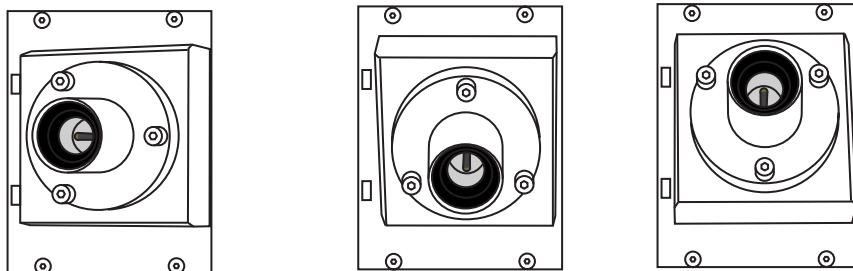

Intercom Connector - Panel View

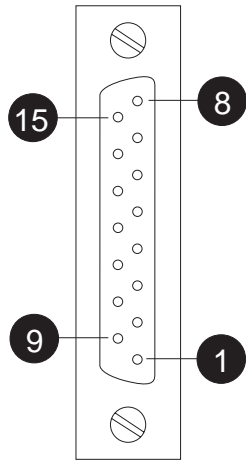

15-pin female, shielded cable

1. Prod. out (4-wire out, 2-wire in/out)
2. Prod. in (4-wire only)
3. Prod. in shield (4-wire only)
4. ENG in (4-wire only)
5. ENG out (4-wire out, 2-wire in/out)
6. Progr. in (4-wire only)
7. Progr. in shield (4-wire only)
8. Housing
9. prod. out return (4-wire out, 2-wire in/out)
10. prod. in return (4-wire only)
11. ENG in shield (4-wire only)
12. ENG in return (4-wire only)
13. ENG out return (4-wire out, 2-wire in/out)
14. Progr. in return (4-wire only)
15. Housing

Shield of cable to the pin marked housing.

4-wire:

Output signals: level +6dBu or 0dBu selectable output impedance 50 ohm (max), symmetrical

Input signals: level +6dBu or 0dBu selectable impedance 9 Kohm (min), symmetrical

2-wire:

level 0dBu
load impedance: 200 ohm
maximum DC level = +40 V between pin 1 (+) and pin 9 (-), pin 5 (+) and pin 13 (-), pin 6 (+) and pin 14 (-).

X374

15-pin female

Panel part number 2411 022 06239
Cable part number 2411 022 05168

WARNING! Applying the wrong DC polarity between these pins may cause damage to the audio/intercom board!

2 - Wire configuration

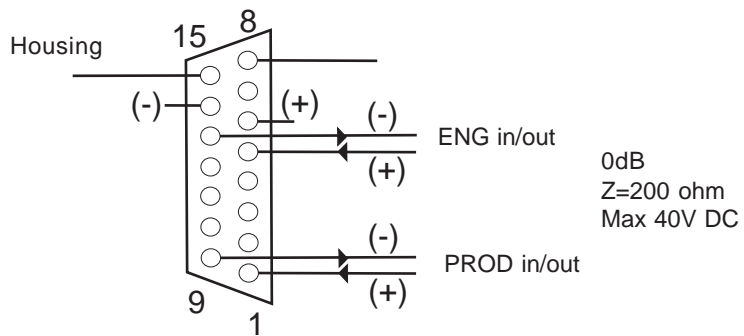

4 - Wire configuration

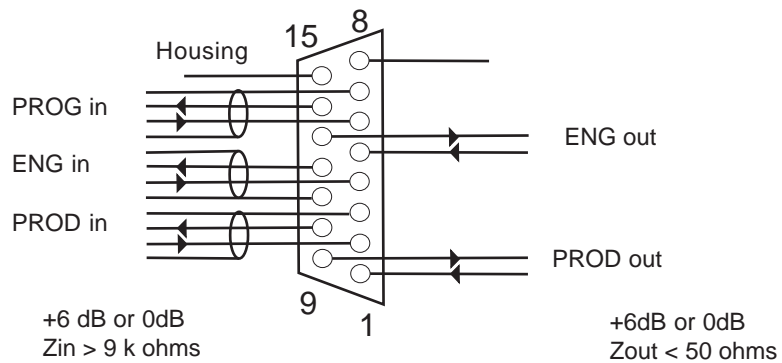

RS232 Connector - Panel View

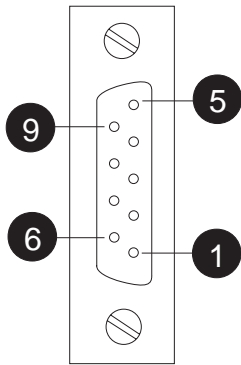

1. SPARE
2. RS-RXD - Receive Data
3. RS-TXD - Transmit Data
4. RS-DTR - Data Terminal Ready
5. RS-DGND - Signal Ground
6. RS-DSR - Data bSet Ready
7. RS-RTS - Request To Send
8. RS-CTS - Clear To Send
9. +12V

X7 Data Board 9-pin male
X379 Signal Connector Board

Panel part number 2422 025 12962
Serial Interface Cable 4822 872 03413

Auxiliary Connector - Panel View

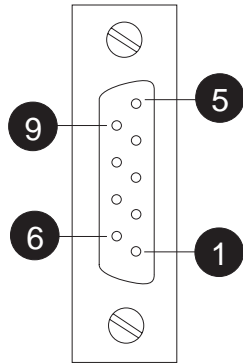

X371

9-pin female

Panel part number 2411 022 06238
Cable part number 2411 022 05284

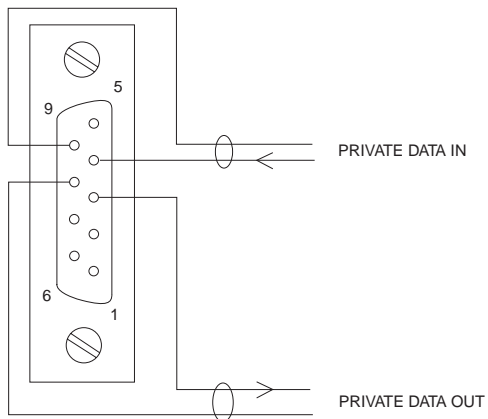

9-pin female, shielded cable

1. +5V
2. AN 0
3. PRIVATE DATA OUT
4. PRIVATE DATA IN
5. Housing (Shield of cable to this pin)
6. GND
7. AN 1

For aspect ratio switching on wide screen sensor cameras:

16:9 -0.5 to +0.8Vdc

4:3 +2.4 to +5.5Vdc

8. PRIVATE DATA OUT RET
9. PRIVATE DATA IN RET

Shield of cable directly to the connector housing.

AUX (private data BS - CAM)

: "0"= 0V +/- 0.5V

: "1"= 5V +/- 0.5V

Rout = 150 ohm

Baudrate typ 2400 bits/sec

max 4800 bits/sec

Duty cycle difference between input and output is max 5%

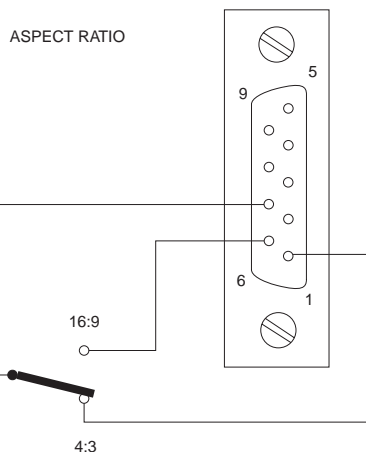

Signalling Connector - Panel View

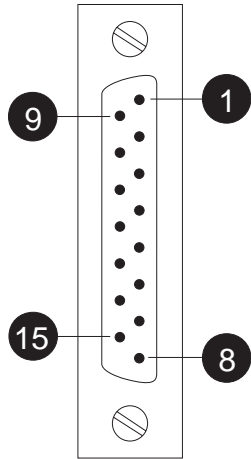

15-pin male, shielded cable

1. Prev. out ext. (relay contact < 10 ohm)
2. Call out ext. (relay contact < 10 ohm)
3. Iso in ext. (dry contact)
4. On-Air in ext (dry contact)
5. Call in ext. (dry contact)
6. Audio 1 level (analogue input voltage 0V to +5V, see figure below)

- 64 dB	-----	0V
- 58 dB	-----	+0.7V
- 52 dB	-----	+1.3V
- 46 dB	-----	+1.9V
- 40 dB	-----	+2.5V
- 34 dB	-----	+3.1V
- 28 dB	-----	+3.7V
- 22 dB	-----	+4.3V

X 370 15-pin male; panel view
 Panel part number 2411 022 05292
 Cable part number 2411 022 06157

7. +5 Vdc; OCP
8. Housing
9. Prev. out ext. return
10. Call out ext. return
11. Iso in ext. return
12. On-Air in ext. return
13. Call in ext. return
14. Audio 2 level (see pin 6)
15. GND

Shield of cable to the pin marked housing.

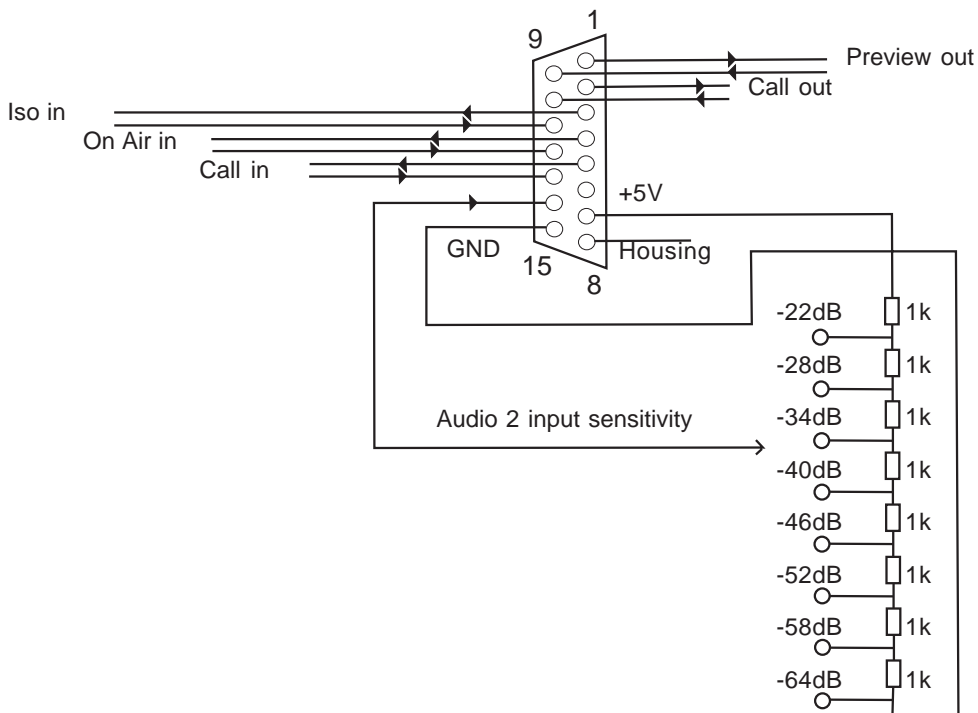

When the Iso, On-Air or Call signal is provided by a dry contact, connect the outputs to the signalling connector as shown in this figure.

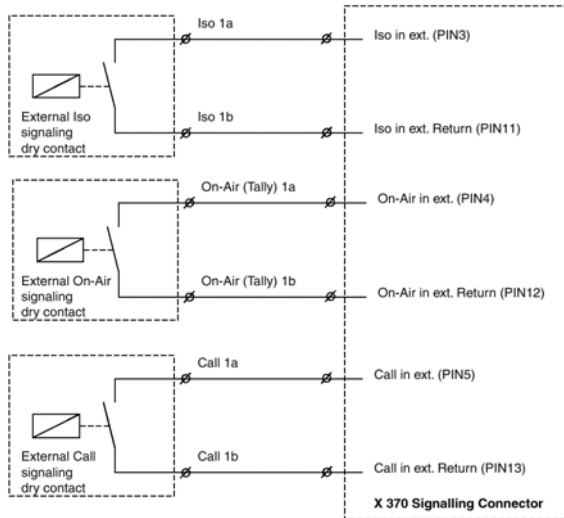

When the Iso, On-Air or Call signal is provided by a dry contact with a common return connector connect the outputs to the signalling connector as shown in this figure.

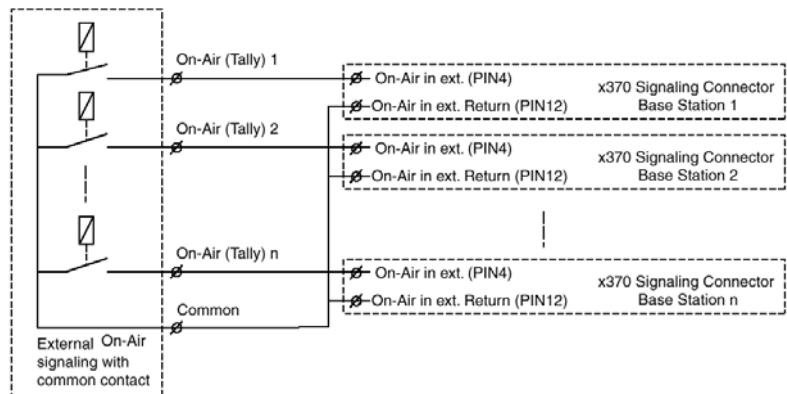

When the Iso, On-Air or Call signal is provided by a DC output voltage connect the outputs to the signalling connector as shown in this figure.

Notes: The Iso, On-Air and Call signal is off if the input voltage is 5..24 VDC. The Iso, On-Air and Call signal is on if the input voltage is 0 VDC. The x370 Signalling inputs are not galvanically separated. We recommend using dry contacts and when these are not available using galvanically separated DC voltage outputs.

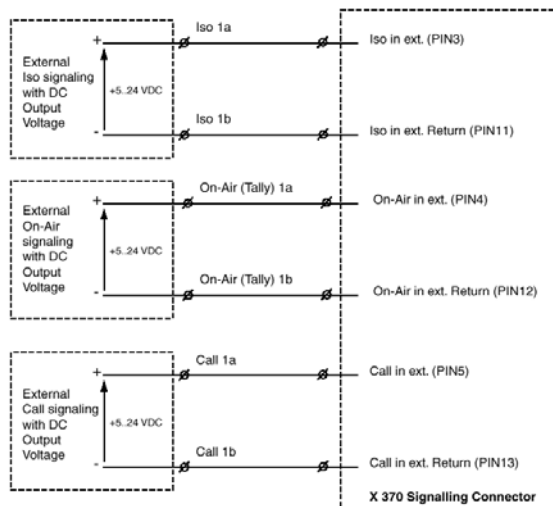

Audio Connector - Panel View

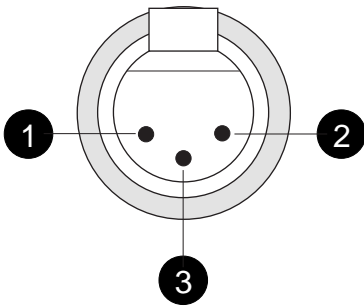

1. shield
2. Audio +
3. Audio -

Microphone impedance >200 ohm

Sensitivity remote controlled via base station:
range: -64 to -22 dBu.

Shield of cable directly to the connector housing.

X338/X339

XLR 3-pin male

Panel part number 2422 026 02985
Cable part number 2432 026 00185

Data Connector - Panel View

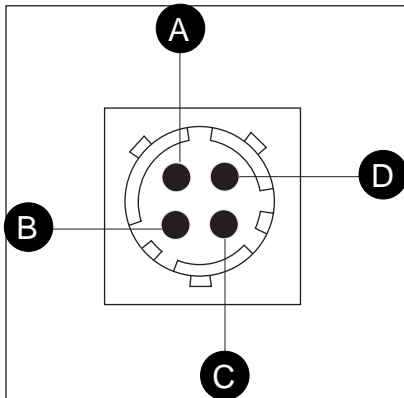

4-pin male, shielded cable

- A. Data
- B. Data not
- C. Not connected
- D. Shield

Shield of cable to the pin marked housing.

X368 / X378

4-pin male

Panel part number 2411 020 11367
Cable part number 2411 020 12025

Mains Input Connector - Panel View

Input power supply voltage indicator

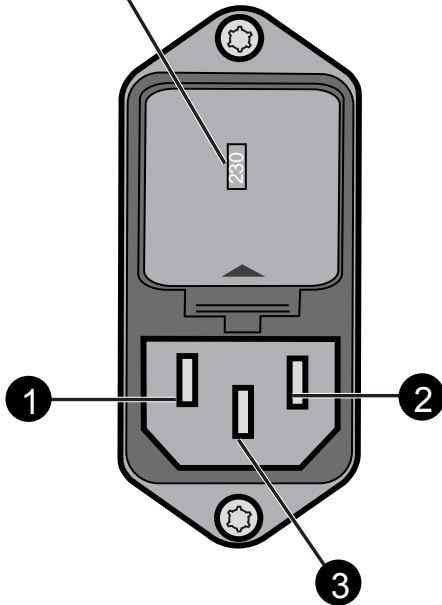

CAUTION

The voltage indication printed on the fuse holder must correspond to the supplied voltage. If it does not correspond, change the fuse holder.

There are two types of fuse holder supplied. One for a nominal input voltage of 230 Vac (4AT) and the other for a nominal input voltage of 115 Vac (10AT).

Eurostyle 3-pin male

1. Neutral
2. Line
3. Earth

Mains input voltage: 230 Vac or 115 Vac

Fuses: 4AT or 10AT

Mains frequency: 47 to 63 Hz

Power consumption: 320 Watt

Link Connector - Panel View

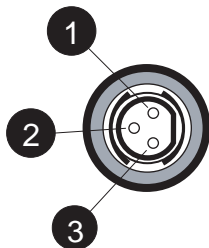

3-pin female, shielded cable

1. Data link
2. Data link N
3. Housing

Shield of cable to the pin marked housing.

X380

Fischer 3-pin female

Panel part number
Cable part number

3922 040 02881
2432 026 00274

FOR FUTURE USE ONLY

Headset Connectors - Panel View

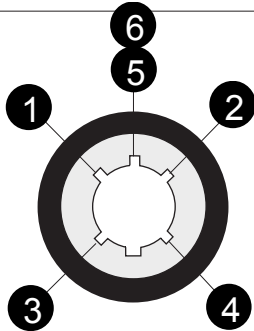

X574 Tuchel 5-pin female
Panel part number
Cable part number

Headset Connector

Tuchel 5-pin female

1. Telephone left
 2. Telephone return
 3. Microphone
 4. Microphone return
 - 5/6. Telephone right
- Shield of cable directly to the connector housing.

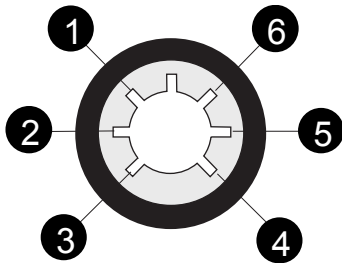

X574 Tuchel 6-pin female
Panel part number
Cable part number

Tuchel 6-pin female

1. Telephone left
 2. Telephone return
 3. Microphone
 4. Microphone return
 5. Telephone right
 6. Telephone return
- Shield of cable directly to the connector housing.

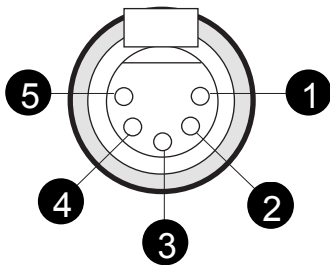

X574 XLR 5-pin female
Panel part number 2422 026
Cable part number

XLR 5-pin female

1. Microphone return
 2. Microphone
 3. Telephone return
 4. Telephone left
 5. Telephone right
- Microphone level -64dBu
Microphone impedance 200 ohm
Telephone level +6dBm nominal
Telephone output impedance <50 ohm
Shield of cable directly to the connector housing.

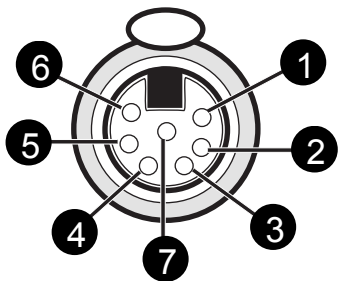

X574 XLR 7-pin female
Panel part number 3922 494 16571
Cable part number

XLR 7-pin female

1. not connected
2. Return
3. ENG Telephone right
4. Return
5. ENG Telephone left
6. Return
7. ENG Microphone

Triax Connectors - Panel View

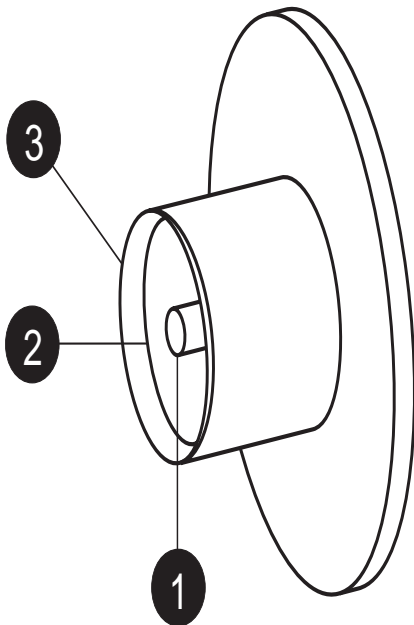

Triax Connectors

Fischer

- 1. Inner pin: Signals + power
- 2. Inner shield: Return
- 3. Outer shield: Base Station housing

Trilock

- 1. Inner pin: Signals + power
- 2. Inner shield: Return
- 3. Outer shield: Base Station housing

ARD

- 1. Inner pin: Signals + power
- 2. Inner shield: Return
- 3. Outer shield: Base Station housing

X540	Fischer male
Panel part number	3922 407 30531
X540	Trilock female
Panel part number	3922 407 30551
X540	ARD female
Panel part number	3922 407 30571
X540	LEMO 3 female
Panel part number	3922 407 30631
X540	LEMO 4 female
Panel part number	3922 407 30591
X540	LEMO BBC male
Panel part number	3922 407 30611

Lemo 3

- 1. Inner pin: Signals + power
- 2. Inner shield: Return
- 3. Outer shield: Base Station housing

Lemo 4

- 1. Inner pin: Signals + power
- 2. Inner shield: Return
- 3. Outer shield: Base Station housing

Lemo BBC

- 1. Inner pin: Signals + power
- 2. Inner shield: Return
- 3. Outer shield: Base Station housing

The panel partnumbers are the connectors including the assembly.

Intercom

The intercom functions available are determined by the configuration of the base station. The Headset board and the Audio/Intercom board are optional. This results in four possible configurations:

1. Headset board present - Audio/Intercom board absent
2. Headset board absent - Audio/Intercom board present
3. Both boards present
4. Both boards absent

If both boards are absent then there are no intercom facilities available. The other configurations are shown in the figures below.

Depending on your camera configuration, consult the cross-reference tables to see which menu positions should be used for both camera and base station menus for routing the intercom signals.

Intercom settings

(Headset board present - Audio/Intercom board absent in Base Station)

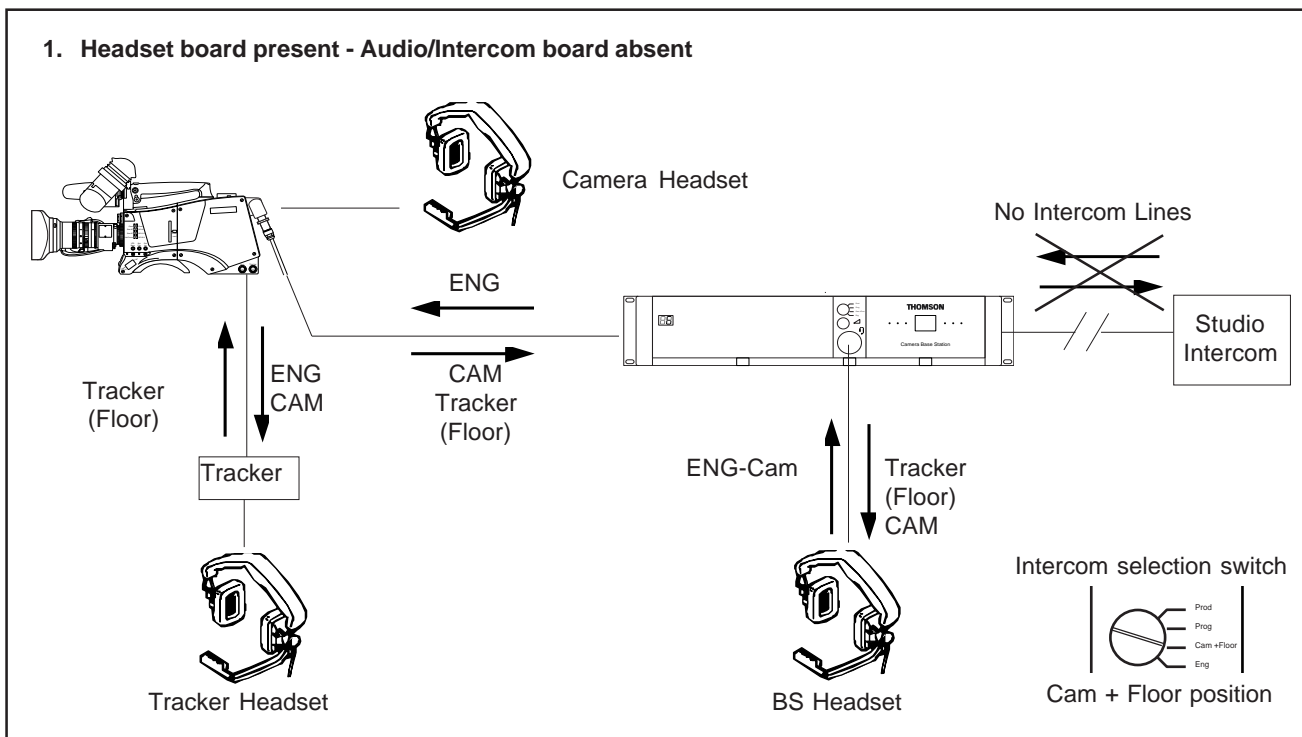

Intercom settings for LDK 5000 camera
(Headset board present - Audio/Intercom board absent in Base Station)

LDK 5440 Triax adapter

T O F R O M	Tracker Headset	Camera Headset	BS Headset
Tracker Mic (Phantom Power !)	Tracker Output = ENG Channel Camera system menu: Install \ Intercom \ Trackmic to ≠ Off Install \ Intercom \ Track Source = Side	Camera system menu: Install \ Intercom \ Trackmic to ≠ Off Install \ Intercom \ Camtrack ≠ Off Install \ Intercom \ Camlevel > 0	Camera system menu: Install \ Intercom \ Trackmic to ≠ Off BS system menu: Audio/Intercom \ ENGheadset \ Tracker to headset = On Audio/Intercom \ ENGheadset \ Tracker volume > 0 BSfront: Intercom selection switch = Cam + Floor
Camera Mic (Phantom Power !)	CAM Channel Tracker Output = Camera Channel Cam Mic = On* Camera system menu: Install \ Intercom \ CamMic to = CH1 ENG Channel Tracker Output = ENG Channel Camera system menu: Install \ Intercom \ Track Source = Side Install \ Intercom \ CamMic to = Ch2	Camera system menu: Install \ Intercom \ CamMic = On Install \ Intercom \ Side tone > 0	Camera system menu: Install \ Intercom \ Cammic to = CH1 (If = CH2, then monitoring via floor) BS system menu: Audio/Intercom \ ENG headset \ Cam to headset = On Audio/Intercom \ ENG headset \ Cam volume > 0 Audio/Intercom \ ENG headset \ Floor to headset = On BSfront: Intercom selection switch = Cam + Floor
BS Headset Mic (Phantom Power !)	Tracker Output = ENG Channel Camera system menu: Install \ Intercom \ Track Source = ENG BS system menu: Audio/Intercom \ ENGHeadset \ Mic to ENG-Cam = On	Camera system menu: Install \ Intercom \ Camengineering ≠ Off BS system menu: Audio/Intercom \ ENGHeadset \ Mic to ENG-Cam = On	BS system menu: Audio/Intercom \ ENGheadset \ Sidetone > 0

- * Other ways to switch on camera microphone:
- Camera: Start button = On
 - Camera: Intercom Routing Switch = ENG or PROD

Intercom settings for LDK 5000 camera

(Audio/Intercom board present - Headset board absent in Base Station)

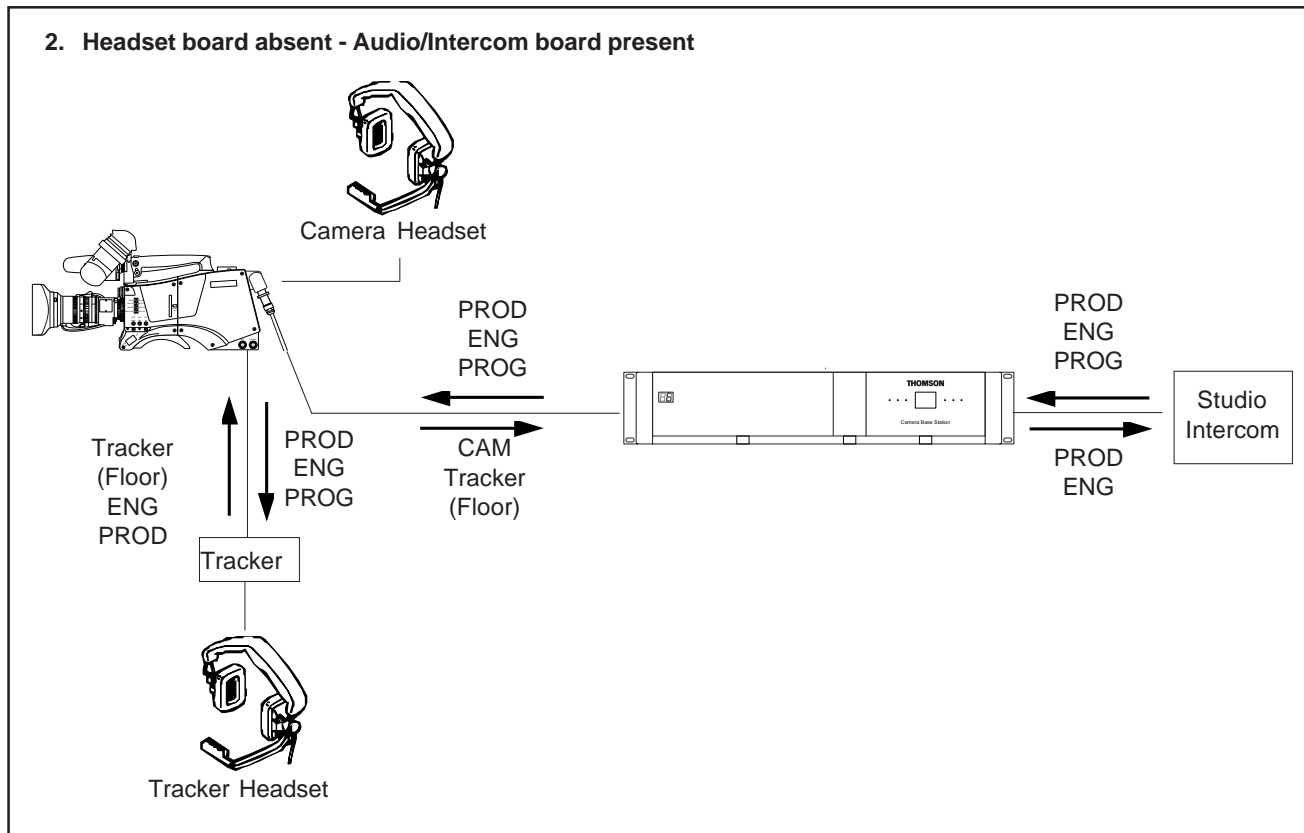

Tracker or Base station signals are not available

Intercom settings for LDK 5000 cameras (Audio/Intercom board present - Headset board absent in Base Station)

LDK 5440 Triax adapter

FROM \ TO	Tracker Headset	Camera Headset	Studio PROD	Studio ENG
Tracker Mic (Phantom Power 1)	Tracker box = ENG Channel Camera system menu: Install \ Intercom \ Trackmic to = Off Install \ Intercom \ TrackSource = Side	Camera system menu: Install \ Intercom \ Trackmic to = Off Install \ Intercom \ Camtrack = Off Install \ Intercom \ CamLevel > 0	Camera system menu: Install \ Intercom \ Trackmic to = All or Prod BS system menu: Audio \ Intercom \ Intercom \ Isolate \ Isolate = Syst	Camera system menu: Install \ Intercom \ Trackmic to = All or ENG BS system menu: Audio \ Intercom \ Intercom \ Isolate \ Isolate = Syst
Camera Mic (Phantom Power 1)	CAM Channel Tracker box = Camera Channel Cam Mic = On * Camera system menu: Install \ Intercom \ CamMic to = CH1 ENG Channel Tracker box = ENG Channel Camera system menu: Install \ Intercom \ TrackSource = Side Install \ Intercom \ CamMic to = CH2	Camera system menu: Install \ Intercom \ CamMic = On Install \ Intercom \ Sidetone > 0	BS system menu: Audio \ Intercom \ Intercom \ Isolate \ Isolate = Syst Camera intercom routing switch = Prod (or camera start button = on)	BS system menu: Audio \ Intercom \ Intercom \ Isolate \ Isolate = Syst Camera intercom routing switch = ENG
Studio PROD	Tracker box = PROD Channel	Camera system menu: Install \ Intercom \ Camproduction # OFF	Not available	Not available
Studio ENG	Tracker box = ENG Channel Camera system menu: Install \ Intercom \ TrackSource = ENG	Camera system menu: Install \ Intercom \ Camengineering # OFF	Not available	Not available
Studio PROG	Tracker box = PROG Channel	Camera system menu: Install \ Intercom \ Camprogram # OFF	Not available	Not available

* Other ways to switch on camera microphone:

- Camera : Start button = On
- Camera : Intercom Routing Switch = ENG or PROD

Intercom settings for LDK 5000 camera

(Audio/Intercom board and Headset board present in Base Station)

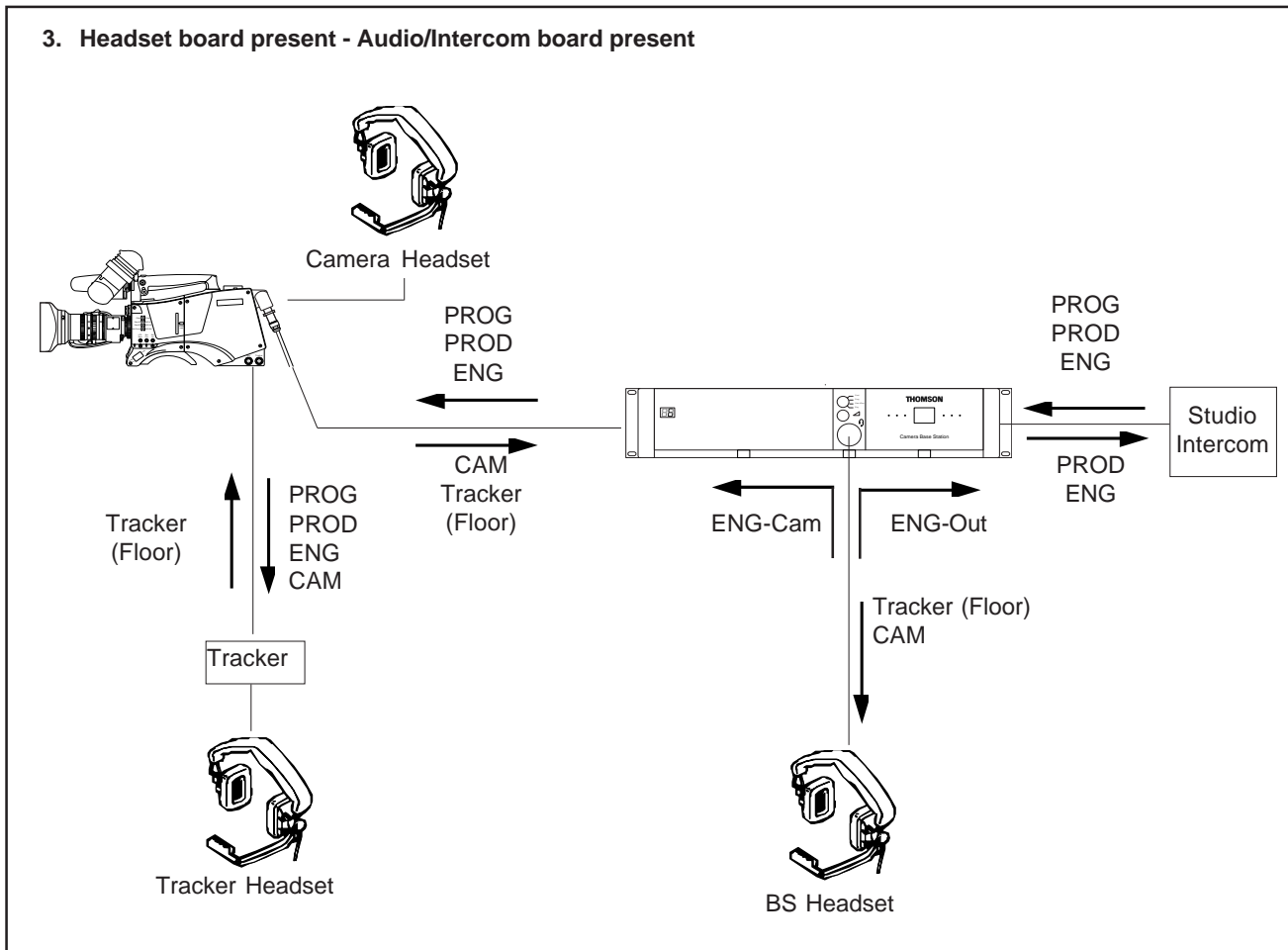

Intercom settings for LDK 5000 camera (Audio/Intercom board and Headset board present in Base Station)

LDK 5440 Triax adapter

FROM	TO	Tracker Headset	Camera Headset	BS Headset	Studio PROD	Studio ENG
Tracker Mic (Phantom Power 1)	Tracker box = ENG Channel Camera system menu: Install \ Intercom \ Trackmic to= Off Install \ Intercom \ CamTrack= Off Install \ Intercom \ TrackSource= Side	Camera system menu: Install \ Intercom \ Trackmic to= Off Install \ Intercom \ CamTrack= Off Install \ Intercom \ CamLevel > 0	Camera system menu: Install \ Intercom \ Trackmic to= Off Install \ Intercom \ CamTrack= Off Install \ Intercom \ CamLevel > 0	Camera system menu: Install \ Intercom \ Trackmic to= Off BS system menu: Audio/Intercom \ ENG headset \ Tracker to headset = On Audio/Intercom \ ENG headset \ Tracker volume > 0 BS front: Intercom selection switch = Cam + Floor	Camera system menu: Install \ Intercom \ Trackmic to= All (or Prod) BS system menu: Audio/Intercom \ Isolate \ Isolate# Isol	Camera system menu: Install \ Intercom \ Trackmic to= All (or Prog) BS system menu: Audio/Intercom \ Isolate \ Isolate# Isol
Camera Mic (Phantom Power 1)	CAM Channel Tracker box = Camera Channel Cam Mic = On* Camera system menu: Install \ Intercom \ CamMic to = CH1 ENG Channel Tracker box = ENG Channel Camera system menu: Install \ Intercom \ TrackSource = Side Install \ Intercom \ CamMic to = CH2	Camera system menu: Install \ Intercom \ CamMic = On Install \ Intercom \ Side tone > 0	Camera system menu: Install \ Intercom \ CamMic = On Install \ Intercom \ Side tone > 0	Camera system menu: Install \ Intercom \ Cammic to = CH1 (If = CH2, then monitor via Floor) BS system menu: Audio/Intercom \ ENG headset \ Cam to headset = On Audio/Intercom \ ENG headset \ Cam volume > 0 Audio/Intercom \ ENG headset \ Floor to headset = On BS front: Intercom selection switch = Cam + Floor	BS system menu: Audio/Intercom \ Isolate \ Isolate# Isol Camera intercom routing switch = PROD	BS system menu: Audio/Intercom \ Isolate \ Isolate# Isol Camera intercom routing switch = ENG
BS Headset Mic (Phantom Power 1)	Tracker box = ENG Channel Camera system menu: Install \ Intercom \ TrackSource = ENG BS system menu: Audio/Intercom \ ENG Headset \ Mic to ENG-Cam = On	Camera system menu: Install \ Intercom \ CamEngInsering# Off BS system menu: Audio/Intercom \ ENG Headset \ Mic to ENG-Cam = On	Camera system menu: Install \ Intercom \ CamEngInsering# Off BS system menu: Audio/Intercom \ ENG Headset \ Mic to ENG-Cam = On	BS system menu: Audio/Intercom \ ENG headset \ Sidetone > 0 BS front: Intercom selection switch = Cam + Floor	BS system menu: Audio/Intercom \ Isolate \ Isolate# Isol Eng-Out = On Not available	BS system menu: Audio/Intercom \ Isolate \ Isolate# Isol Eng-Out = On Not available
Studio PROD	Tracker box = PROD Channel	Camera system menu: Install \ Intercom \ CamProduction# Off	Camera system menu: Install \ Intercom \ CamProduction# Off	BS front: Intercom selection switch = PROD	Not available	Not available
Studio ENG	Tracker box = ENG Channel	Camera system menu: Install \ Intercom \ CamEngInsering# Off	Camera system menu: Install \ Intercom \ CamEngInsering# Off	BS front: Intercom selection switch = ENG	Not available	Not available
Studio PROG	Tracker box = PROG Channel	Camera system menu: Install \ Intercom \ CamProgram# Off	Camera system menu: Install \ Intercom \ CamProgram# Off	BS front: Intercom selection switch = PROG	Not available	Not available

* Other ways to switch on camera microphone:

- Camera : Start button = On
- Camera : Intercom Routing Switch = ENG or PROD

Voice Mail

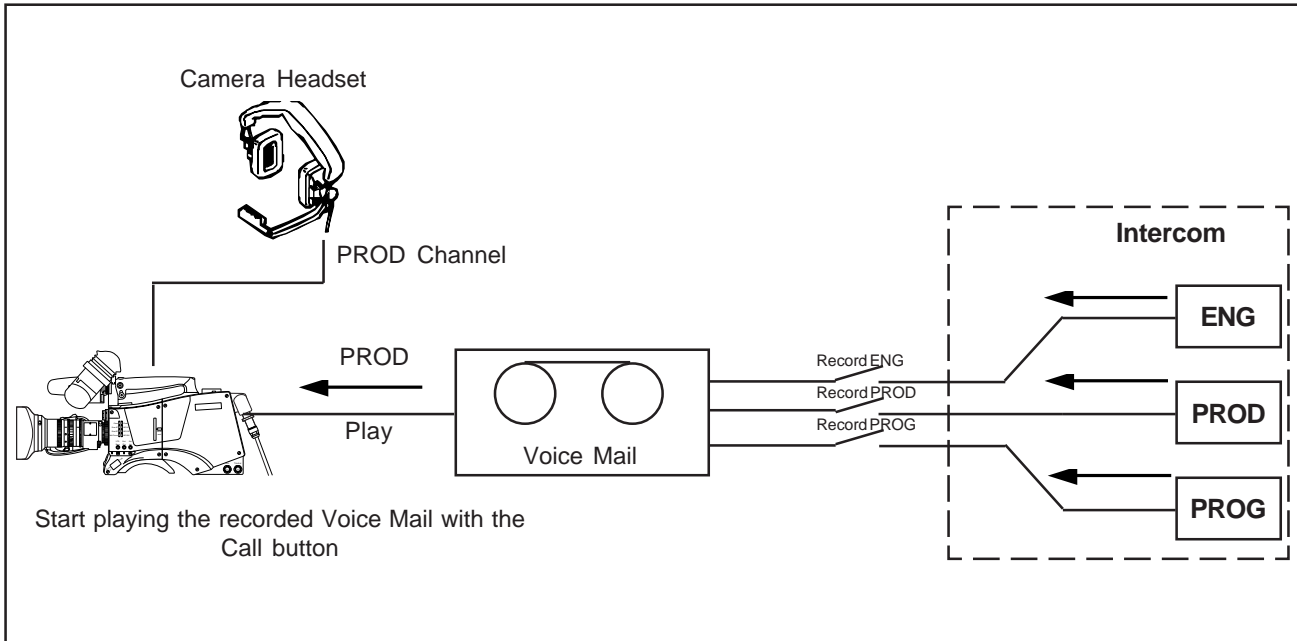

Voice Mail is an intercom message storage function.

Note: Voice mail is only available if the Base Station menu item *Audio/Intercom \ Intercom \ Call* is set to Voice.

Recording

Recording starts automatically at the start of a message. A new message erases the previous recorded message. The maximum message length is 16 seconds. Longer messages are recorded in a retroloop. Only the last 16 seconds are available for playback.

Select the intercom channels to be recorded via the Base Station menu items *Audio/Intercom \ Intercom \ Voice mail \ Record ENG, PROD and PROG*.

Note: The voice mail box can only contain one message. If voice mail recording starts from an other intercom channel the previous message is erased.

Listening to the message

Push the camera call button to start playing out the recorded voice mail to the camera headset. Push the call button again to stop playing the voice mail message.

Private Data

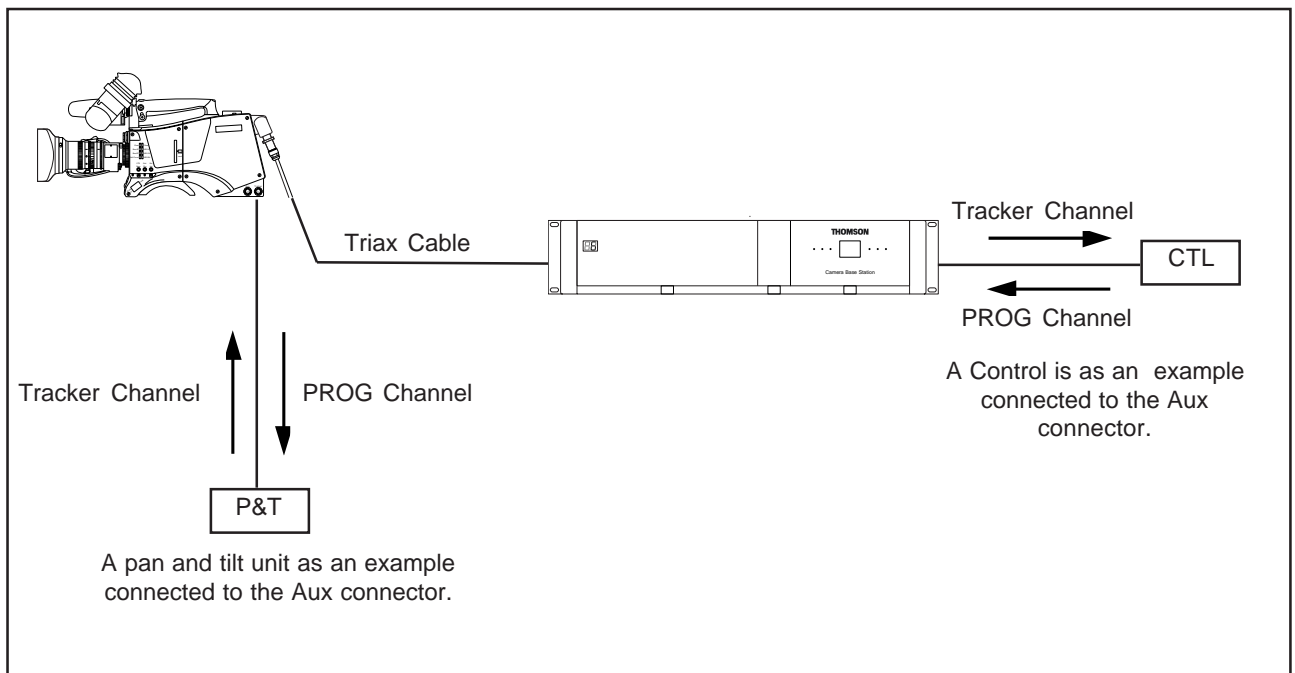

Private data channels can be used for the transmission of serial data via the triax cable. For example, electronic scriptboard or character data for a video display unit can be transmitted to the camera.

The tracker microphone intercom channel is used for the data channel from camera head to Base Station. The program intercom channel is used for the data channel from Base Station to camera head. The input and output signals are available on the auxiliary connectors of the camera and Base Station (for camera see the connectors and cables section). If a channel is used for private data, then of course the original functions are no longer available.

To select the function of the Base Station to camera channel set the Base Station menu item *Audio/Intercom \ Private Data \ PROG Channel* to Priva.

To select the function of the Camera to Base Station channel set the Base Station menu item *Audio/Intercom \ Private Data \ Tracker Channel* to Priva.

Remember that the propagation-delay times are different for different triax cable lengths, especially if a return signal is involved. At maximum lengths of 2400 metres the total delay is at least 25 μ sec. and can be more than 30 μ sec, depending on the type of triax cable.

Data signal specifications

Baudrate: 2400

Input level: TLL, possible RS232

Input impedance: 100Kohm

Output impedance: ~300 ohm

Max load: ~1Kohm

Text Loop-through with multiple base stations

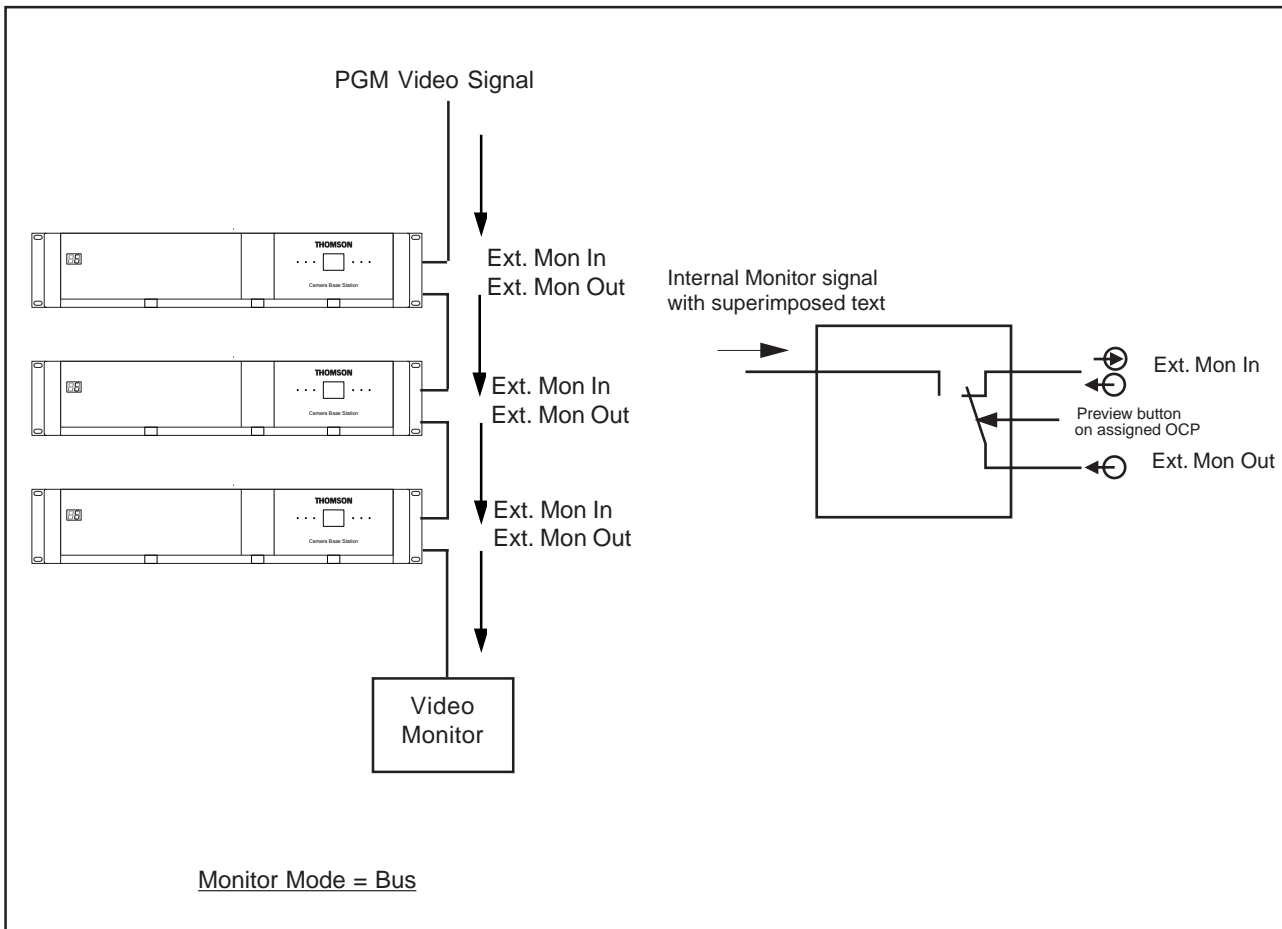

The Base Station menu text can be displayed at the Monitor output. To display the menu text of a selected Base Station proceed as follows:

Installation

- a. Set the Base Station menu item *System \ Monitor Mode* to Bus.
- b. Set the Base Station menu Item *Monitoring \ Menu \ Monitor Output* to On.
- c. Connect the Base Stations in a loop-through monitoring chain.

Note: It is not possible to change the monitor mode if the Monitor mode is set to WFM by hardware. Consult section 2 "System Settings" for detailed information.

Operation

- a. Select the Base Station with the Operational Control Panel's preview button.
- b. Enter the Base Station menu by means of the Operational Control Panel.

Note: Consult the Operational Control Panel User's Guide for detailed information about the Base Station Menu Control mode.

Monitor Mode

The Monitor mode can be set in the Base Station menu
System \ Monitor Mode.

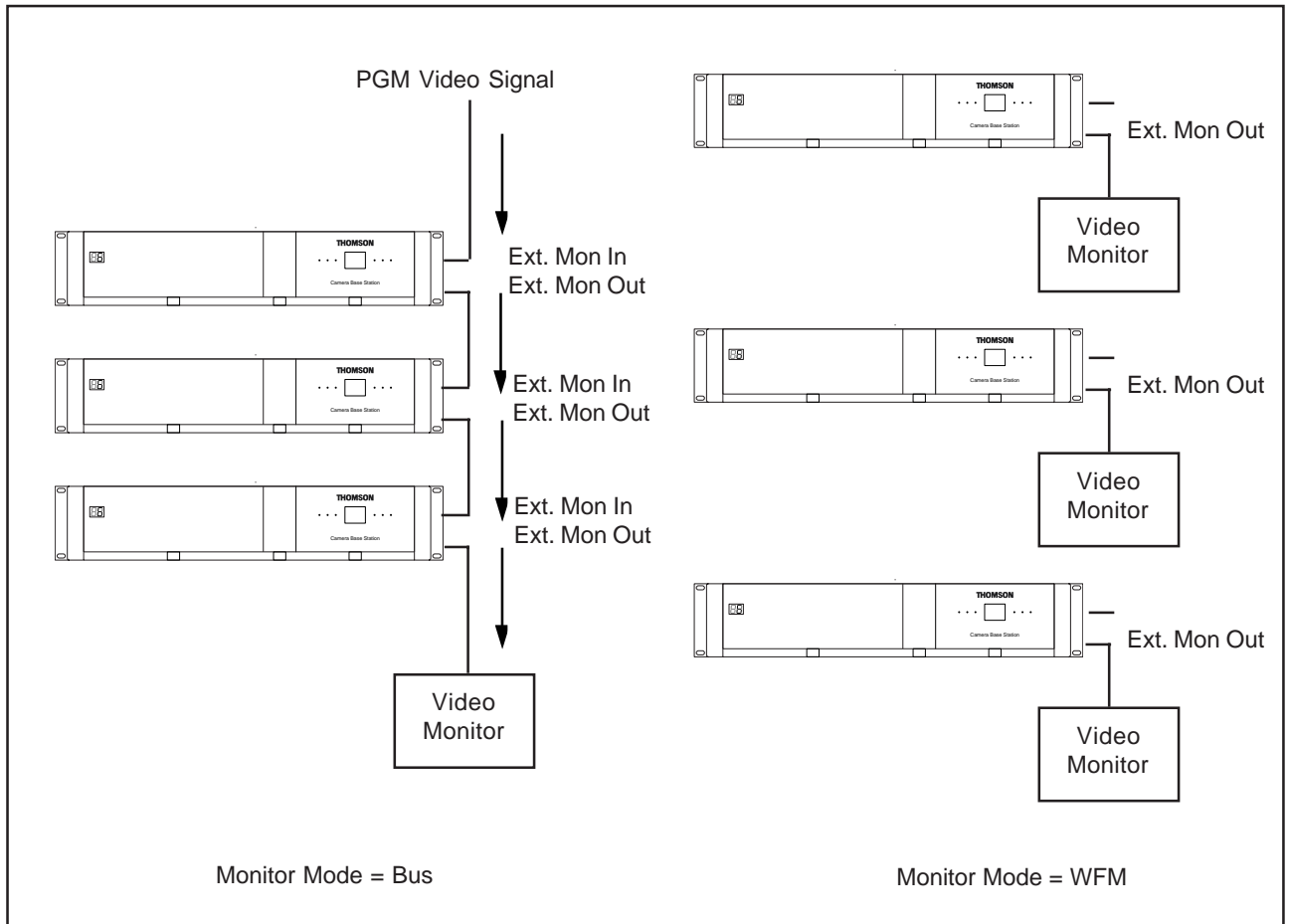

Bus Mode

The Preview button of the connected Operational Control Panel selects if the internal or external monitor signal is provided at the External Monitor output.

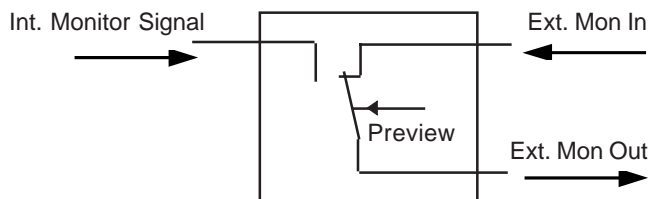

WFM Mode

In WFM mode the External Monitor Output always provides the Internal Monitor Signal.

Note: It is not possible to change the monitor mode if the Monitor mode is set to WFM by hardware.

MCP Available

When no MCP is available it might occur that some functions are in an undesirable position, for example, a lock on the upper part of the OCP. To prevent this happening, set the Base Station menu item *System \ MCP Available* to No when an MCP is not available.

The functions affected by this setting and their state is as follows (if the item value is set to "MCP Available = No"):

Variable black stretch (Yes/No)	Yes
Variable gamma (Yes/No)	Yes
Variable Flare (Yes/No)	Yes
Saturation (Yes/No)	Yes
White clipper (Yes/No)	Yes
Knee slope (Yes/No)	Yes
Knee point (Yes/No)	Yes
Iris(Normal/Reverse)	Normal
OCP lock (Upper/Total)	Total
Intercom (System/Isolate)	System
Audio (External/MCP)	External
Aspect Ratio (External/MCP)	External
Aspect Ratio (4:3/16:9)	4:3
Autolight (Yes/No)	Yes

Specifications

LDK 4505/00	SDTV BASE STATION UNIT	LDK4520	SDTV TRIAX MODULES
General		LDK4520/10	Fischer triax connector
Dimensions (WxHxD)	483 (19" rack) x 88 (2RU) x 510mm. (17.2 x 3.5 x 20.1 inch)	LDK4520/20	Tri-Lock triax connector
Operating temperature	-20°C to +50°C (-4°F to 122°F)	LDK4520/30	ARD triax connector
Storage temperature	-40°C to +70°C (-40°F to 158°F)	LDK4520/40	Lemo 4 triax connector
Operating Humidity	Max. 90% (non condensing)	LDK4520/50	Lemo BBC triax connector
Shock resistance	Max. 10G (transport), Max 2G (operating)	LDK4520/60	Lemo 3 triax connector
Altitude	Max. 50,000 feet		
Weight	Approximately 17.0 kg (37.5 lbs.) fully equipped with options.	LDK4530	EXTERNAL VIDEO IN MODULES
		LDK4530/10	External video module
Transmission		External video in	BNC 2x 1.0Vp-p, +/- 6dB, 75ohm (loop-through) (CVBS or VBS)
Nom. Cable Length	2,000 m. (3,281 ft) <i>(14 mm./0.55" triax cable, S/N ratio 60dB)</i>	LDK4540	AUDIO & INTERCOM MODULES
Max. Cable Length	3,000 m. (4,922 ft) <i>(14 mm./0.55" triax cable, S/N ratio 42dB)</i>	LDK4540/10	2 ch. audio & 2/4-wire intercom
Bandwidth	7/7/7MHz. (+/-3dB), RGB or Y,B-Y,R-Y	Audio out	XLR-3 2x, 0/+6dBu (+/-1.5dB, max. 18dBu, 600ohm, Gain Max. 70dB)
Connectors		Frequency response	40Hz to 15kHz, (+/-3dB, 1kHz, -10dBu output level)
Teleprompter in	BNC 2x 1.0Vp-p, 75ohm (loop-through)	Distorsion	Less than 0.5% <i>(100Hz/1kHz, +6dBu out, 600ohm)</i>
Reference in	BNC 2x 1.0Vp-p, 75ohm (loop-through)	S/N ratio	58dB <i>(unweighted RMS)</i>
SDI out	BNC 6x, 0.8Vp-p, 75ohm <i>(CCIR 601 with EDH, SMPTE RP165)</i>	Intercom in/out	D-sub 15-pin, female (program in, production in/out, engineering in/out <i>in: 0 or 6dBu (max. 6 or 12dBu), 9kohm out: 0 or 6dBu (+/- 2dB, max. 12dBu), 600ohm)</i>
Text out	BNC 1x 1.0Vp-p, 75ohm (VBS)	Frequency response	150Hz to 6kHz <i>(1kHz, -10dBu output level)</i>
Auxiliary out	BNC 1x 1.0Vp-p, 75ohm <i>(CVBS, replaces teleprompter input)</i>	Distortion	Less than 2% <i>(1kHz, +12dBu level)</i>
Reference out	BNC 1x 0.3Vp-p, 75ohm <i>(BB, if external reference in not available)</i>	LDK4541	ENGINEERING INTERCOM MODULE
Composite video out	BNC 1x 1.0Vp-p, 75ohm <i>(CVBS, multi standard w/ or w/o text, NTSC acc. SMPTE 170M, PAL acc. ITU 624)</i>	LDK4541/10	XLR-5 engineering intercom module
Signalling in/out	D-sub 15-pin, male <i>Preview, Green tally (call), dry contact, Yellow tally (I,ISO), dry contact Red tally (on-air), dry contact Remote audio level control (22-64dB), DC</i>	LDK4541/20	Tuchel 6-pin engineering intercom module
Auxiliary in/out	D-sub 9-pin, female <i>An0, 0-5Vdc in, output on camera head An1, 0-5Vdc in, or aspect ratio remote control, 16:9<0.8Vdc in, 4:3>2.4Vdc in Private data in/out, 2.4kB TTL (RS-232)</i>	LDK4541/30	Tuchel 5-pin engineering intercom module
RS-232	D-sub 9-pin, male <i>(RXD, TXD, DTR, DSR, RTS, CTS)</i>	LDK4541/40	XLR-7f engineering intercom module <i>(6dBu, +/-2dB, max. 12dBu, 25-400ohm)</i>
Control data	4-pin, male <i>(Series 9000, 2-wire camera control bus)</i>	Frequency response	150Hz to 6 kHz, +/-3dB (0dB, 1kHz, -10dBu output level)
Link	3-pin, female <i>(Feature box control link)</i>	S/N ratio	46dB <i>(unweighted RMS)</i>
		Phantom power	+12Vdc (+/-1V), menu selectable
LDK4510	POWER MODULES	LDK4560	MONITORING MODULES
LDK4510/10	AC/DC power module for studio and portable camera heads	LDK4560/10	Bus monitor with preview control or WFM output
Power requirement	AC 115V/230V +/- 15%, 47 to 63 Hz	Composite video out	BNC 2x 1.0Vp-p, 75ohm (loop-through) <i>(CVBS, Y, R, G, B, RGB sequential, RGB superimpose, Ext. 1, Ext. 2, Ext. 1 + Y or Ext. 2 + Y)</i>
Power connector	IEC type, 3-pin male	Frequency response	0.1 to 5MHz (+0.5/-1dB)
Power consumption	470 VA or 270 Watts max. <i>(with studio camera head)</i> 360 VA or 210 Watts max. <i>(with portable camera head)</i>	Kfactor	Less than 2%
Utility power	150 VA or 150 Watts max. <i>(on studio camera head)</i> 80 VA or 80 Watts max. <i>(on portable camera head)</i>		

Section 3

Operating Instructions

This section describes the structure of the camera base station control system. This section explains how to control and program the menu system and how to set up the menu system to suit your personal preferences. The menu structure and the methods of function selection are also explained. The appendix shows the contents of the menu system.

Contents

Introduction	3-2	Set-up	3-4
Front panel	3-3	Using the Menu System	3-5

Introduction

The flexible design of the base station means that it can be integrated into a variety of configurations in studios or OB vans. To make full use of its extensive functionality it provides many facilities for setting it up. Once set up, operation is virtually transparent.

We recommend that you spend time using the various controls and displays in order to fully discover the wide range of features. Read the instructions in this section carefully but also feel free to examine the various menus in detail. In this way you will learn quickly to intuitively use the system.

Simple set-up

The Rotary/Push button behind the left front cover can be used to control some basic set-up functions. It can also be used to navigate through the menu system.

Menu System

The menu system is used for setting up and configuring the base station. As there are a large number of functions and set-up options available, it may require some time for you to become familiar with them all.

OCP menu control

Although the Rotary/Push button can be used to navigate through the menu system, it is more convenient to use the OCP connected to the Base Station. (Refer to the OCP user guide to find out how to do this.)

Viewing the menu

The System Menu video signal is available on the Text output of the base station. The System Menu text can also be superimposed on the CVBS and the Monitor output if desired. Consult the section "Text Loop-through with Multiple Base Stations" for viewing the menu text through the monitoring bus.

Front panel

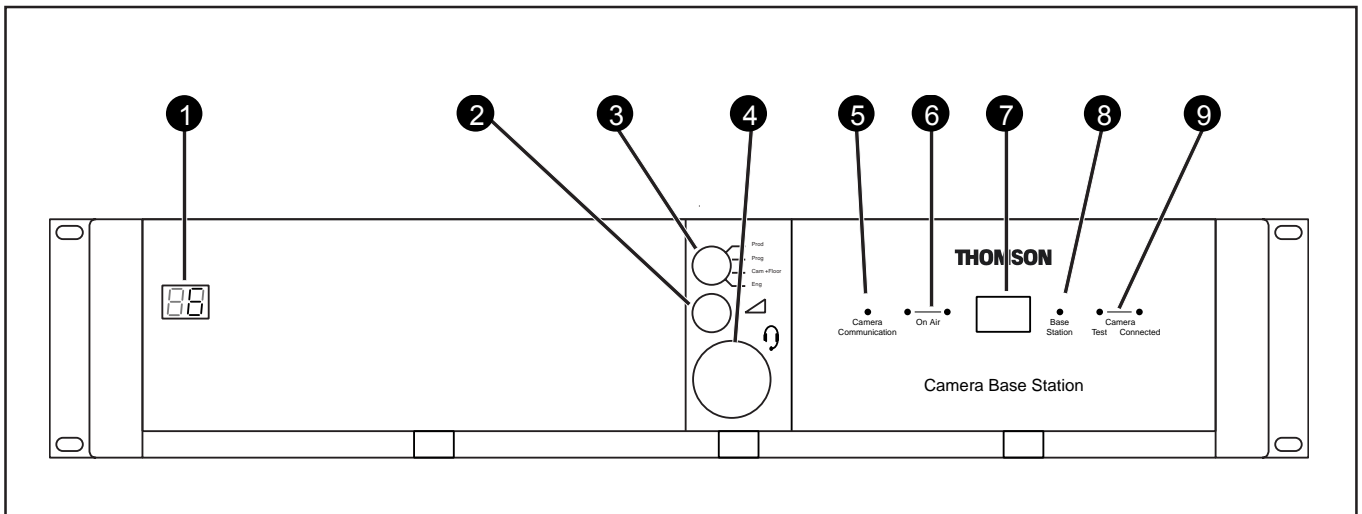

1 Display

During normal operation the display shows the number of the camera connected to the Base Station.

When the set-up control (located behind the left front cover) is activated, the display shows a two letter code to identify the set-up function (see Set-Up).

The display can be switched on or off via the Base Station menu system.

2 Intercom volume control

Adjusts the volume of the selected intercom channel being monitored on the connector below.

3 Intercom selection switch

Use this switch to select the intercom channel that is monitored on the connector below.

4 Intercom connector

Connect a headset to this connector to monitor the selected intercom channel.

5 Camera Communication

This green LED lights when the communications between Camera and Base Station are OK.

6 On Air and ISO indicators

The red LED lights when the Camera is On Air. If the Camera is selected as ISO Camera the yellow LED lights.

7 Power Switch

Switches the power supply to the Base Station on and off. A built-in light lights to indicate that the power is ON.

8 Base Station

This green LED lights when the Base Station is operationally ready.

9 Camera indicators

This bicolour TEST LED lights red or yellow to indicate the Camera and Triax status:

- Red lights continuously – Triax short circuit.
- Red flashes – Triax open circuit.
- Yellow – Camera power switched off with the Operational or Master Control Panel.

This green CONNECTED LED lights when the Camera is connected and the Camera power switch is On.

Set-up

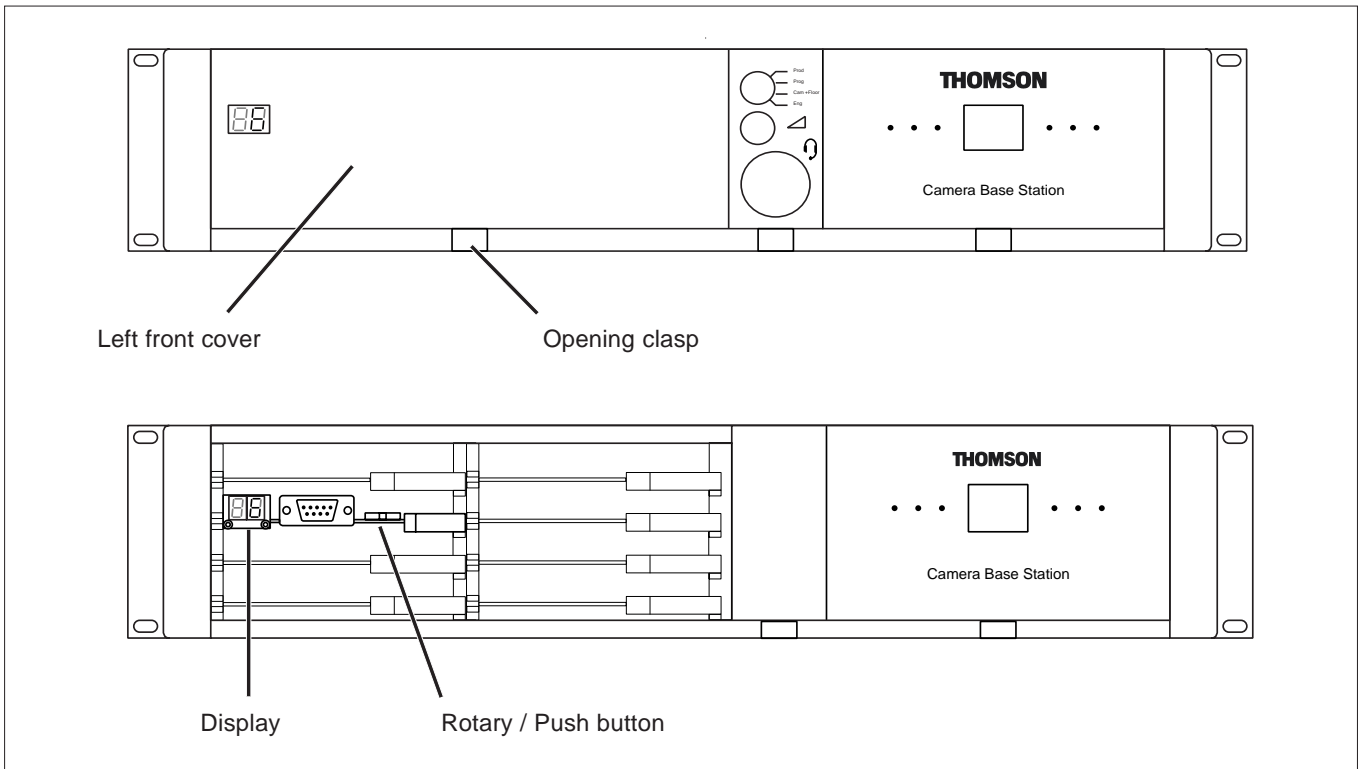

Set-up items

There are four items that can be accessed via the set-up Rotary/Push button on the Data Board:

- Camera number (CA)
- Subcarrier adjustment (SC)
- H-phase (HP)
- System menu (NN)

Remove the left front cover to access the Rotary/Push button on the Data Board.

Rotate the button to the left or right to select the required item. The display shows the abbreviation of the current item.

Camera Number (CA)

When CA is displayed, push the Rotary/Push button to enter the selection mode. Rotate the button to the left or right to select an available camera number. Push the Rotary/Push button to set the new camera number. The Base Station automatically resets and the new camera number is shown in the display.

Subcarrier (SC)

When SC is displayed, push the Rotary/Push button to enter the Subcarrier adjustment mode. Rotate the button to the left or right to shift the Subcarrier phase. If you continue to rotate

the button, the shift change occurs in bigger steps. Push the Rotary/Push button to leave the Subcarrier adjustment mode.

H-Phase (HP)

When HP is displayed, push the Rotary/Push button to enter the H-Phase adjustment mode. Rotate the button to the left or right to shift the H-Phase. If you continue to rotate the button, the shift change occurs in bigger steps. Push the Rotary/Push button to leave the H-Phase adjustment mode.

System Menu (NN)

When NN is displayed, push the Rotary/Push button twice to enter the System Menu. The Rotary/Push button can be used to navigate through the menu system, however, it is more convenient to use the OCP connected to the Base Station. (Refer to the OCP user guide to find out how to do this.)

The System Menu video signal is available on the Text output of the base station. The System Menu text can also be superimposed on the CVBS and the Monitor output if desired.

Using the Menu System

Entering the Systems menu

The system functions of the base station are grouped into menus and sub-menus. Rotate the Rotary/Push button to the left or right to select the Systems Menu. The display shows the abbreviation NN. Push the Rotary/Push button twice to enter. The Main menu appears on the monitor.

Note:

Navigating the system menu is also possible with the LDK4628 and LDK4629 Operational Control Panels. Refer to their respective User's Guide for information on how to do this.

The main menu screen shows five items and the name of the menu. One more item is hidden but becomes visible when you scroll down.

A cursor shows your position in the menu. The Rotary/Push button moves the cursor up and down.

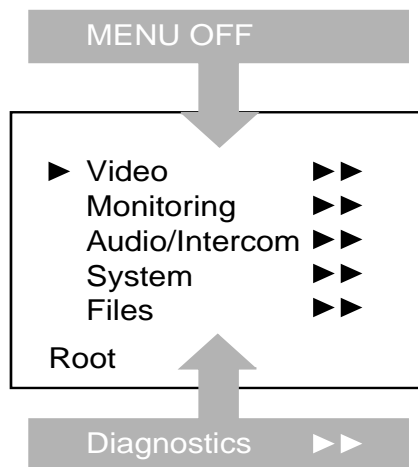

Finding your way

Use the Rotary/Push button to move the cursor through the menu items. If a double arrow (>>) is visible, then pressing the Rotary/Push button brings you one level lower in the menu system. Only five items are visible in each menu. Scroll up or down to see any additional items.

When you first enter a menu (other than the main menu) the cursor is positioned next to the first item.

The TOP and PREVIOUS entries are not immediately visible but are located above the first item. Use the Rotary control to scroll up to them.

- Select TOP to bring you back to the MAIN menu.
- Select PREVIOUS to go back to the menu that you were in before the current one.

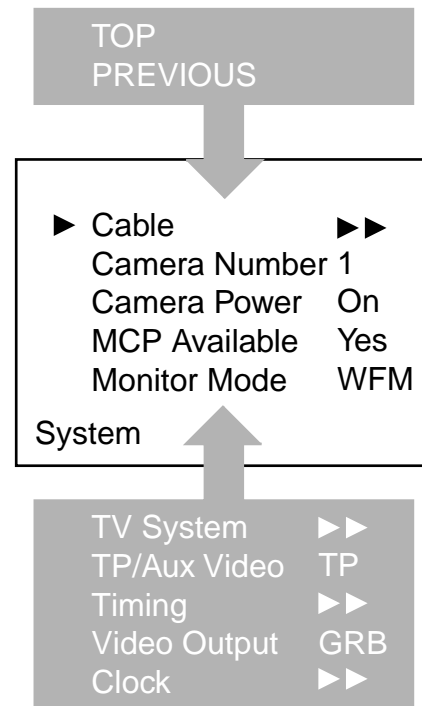

The SYSTEM menu above shows the items displayed when you first enter the menu and the other items that are available by scrolling up or down with the Rotary control.

Leaving the Systems Menu

If you are deep within the menu structure, follow these steps to leave:

- a. If necessary move the cursor to the left most column with the Rotary/Push button.
- b. Scroll upwards until the cursor points to TOP (this is the main menu).
- c. Press the Rotary/Push button. The cursor now points to the Menu off item of the MAIN menu.
- d. Press the Rotary/Push button to leave the system menu.

This is the recommended way of leaving the system menu.

The menu system disappears after a few seconds when you stop navigating. (This delay can be programmed in the *MONITORING/MENU* menu.) However, when you enter the system menu again you enter at the last position of the cursor and not at the top of main menu.

To prevent confusion the next time you enter the system menu, it is advisable to leave the system menu by returning to the main menu (TOP) and selecting *MENU OFF*.

Making changes

To find out where to change a function, consult the List of System Menu Functions at the end of this section to find out under which menu group or subgroup the function is located.

If the cursor points to an item (and there are no double arrows to indicate a sub-menu) then the item pointed to has a value.

The value can be:

- a toggle value (only two values)
- a list value (more than two values)
- an analogue value (variable from 00 to 99)

or unavailable (---).

If the value is unavailable it cannot be changed. This is indicated by three dashes (---). This can occur, for example, when a function is switched off. The analogue values associated with that function are then unavailable.

If there are only two values associated with the function, then pressing the Rotary/Push button toggles between these two values.

If a value is displayed next to a function that is one of several possible values, then pressing the Rotary/Push button places the cursor in a list menu indicating the value currently selected. Use the Rotary/Push button to point to a new value. Press the Rotary/Push button to return the cursor to the function list.

If an analogue value is displayed next to a function name, then pressing the Rotary/Push button places the cursor in front of the value and the Rotary/Push button is used to change the analogue value. Press the Rotary/Push button to return the cursor to the function list.

Undoing changes

If you make changes to the settings in the Systems menu and you decide not to keep them, use the Recall File function to recall a standard or stored set of values for the parameters. These files are available in the FILES menu.

Menu Structure

Access to the functions on these menus is determined by the user level that has been set. The menus are as follows:

Main (top) menu

The top menu gives access to the other menus.

Video menu

The video menu contains those functions which affect the picture quality.

Monitoring menu

This menu contains the functions which determine how items in the video monitor are displayed.

Audio/Intercom

The functions contained under this menu control various aspects of audio and intercom.

System menu

This menu contains the functions that are used to set up the general configuration and for carrying out adjustments and calibrations of the Base Station.

Files menu

This menu allows values to be stored in System and operator files, and allows these files to be recalled as required.

Diagnostic menu

The diagnostic menu is designed to provide information on the current status of the Base Station.

User Levels

The menu items are divided into two user levels. The operator level "O" is default accessible. Menu items with user level Install "I" are only accessible if the menu level is set to Install.

To enter the Install level proceed as follows:

- a. Enter the menu.
- b. Navigate to the *Monitoring \ Menu \ Menu level* Item.
- c. Set the Menu level to Inst.

The purpose of the user levels is to restrict the set of functions which can be changed by whoever is using the Base Station. In this way a the danger of the operator accidentally changing critical functions while shooting is reduced.

The system Menu Structure paragraph of this section indicates which functions are available at each user level.

Video menu - Special features

Auto lighting

The Auto Lighting item of the the video menu compensates for variations in the frequency of the power supply used for gas discharge lamps (fluorescent or HMI lighting).

The frequency of power supply generators can vary from the nominal value. This variation affects the lighting which in turn affects the colour balance. If camera system and lighting are supplied by the same power source, then the base station auto lighting function can automatically adjust the exposure to follow the variations and maintain a constant colour balance. This correction only works when the camera exposure time is set to the 50Hz or 60Hz position.

Gain adjustment

The Gain Adjustments item of the the video menu is a special item. It combines menu items from various other menus to help you when you are adjusting the gain. It should only be used when carrying out the gain adjustments on the Sync/Encoder board in conjunction with the procedure given in section 5.

Section 3 -Appendix

Menu System

Contents

System Menu Structure	A3-2	List of Abbreviations	A3-13
List of System Menu Functions	A3-10		

System Menu Structure

The system Menu tables present the functions ordered in the logical divisions of the menu system itself with additional information in the columns:

- **User level column**
The User level column indicates the functions that are available with different user levels.
- **Values column**
All available choices are listed for a function.
- **Blocked if column**
Lists the conditions that block the function.
- **Default column**
The default column lists the values of the functions when a camera is delivered.
- **Files column**
The File column indicates where the value of the function is stored; in the operator file or in the system file or not at all.
- **Comments column**
The Comments column list information about the function.

MAIN Menu		
Menu text	User	Comments
<Menu Off>	O I	
Video >>	O I	
Monitoring >>	O I	
Audio/Intercom >>	O I	
System >>	O I	
Files >>	O I	
Diagnostics >>	O I	

VIDEO Menu							
Menu text	User	Values	Default	Blocked if	File	Comments	
Chroma >>	O I	On,Off	On	-	Scene	Add colour information to the CVBS signals	
Colour Bar >>							
Colour Bar	O I	On,Off	Off	-	Scene	-	
White Bar Level		75%,100%	100%	-	System	Change white bar level in colour bar	
Auto Lighting	O I	On,Off	Off		Operator	Corrects colour effects due to artificial AC lighting in combination with short exposure time values by adjusting the integration time of the sensor	
Notch >>							
Notch	O I	On,Off	Off	Colour Bar=On	Scene	Suppress visible distortion in hatch patterns	
Level	O I	0..99	50	Colour Bar=On	Scene	-	
EXT Video		On,Off	Off	-	System	Suppress chroma to obtain true luminance on B&W viewfinders with external supplied video signals	
Saturation	O I	0..99	50	Colour Bar=On	Scene	Colour amplitude level for all video outputs	
Gain Adjustments >>						Consult section "Gain Adjustments"	
Consult manual first! >>						-	
Std. System File		CUST,FACT	CUST	-	-	Use CUST file if the customer file contains your default settings	
Recall Std Sys File		exec	-	-	-	-	
Colour Bar	O I	On,Off	Off	-	Scene	-	
White Bar Level		75%,100%	100%	-	System	-	
Chroma	O I	On,Off	On	-	Scene	-	
Options Video Output		GRB,YRyBy, CVBS	GRB	-	System	-	
Options CVBS Y Gain		0..99	50	-	System	-	
Options Chroma Level		0..99	50	-	System	-	
Monitor Mode		WFM,Bus	WFM	Set to WFM by hardware	System	Consult section "System Settings"	
Monitoring Source	O I	CVBS..YExt2	CVBS	Colour Bar=On	Scene	-	
Monitoring CVBS Gain		0..99	50	Colour Bar=On	System	-	
Monitoring YGRB Gain		0..99	50	Colour Bar=On	System	-	
Store Std System File		exec	-	Std. System file=FACT	-	Warning: This will replace the default CUST file	
Cam Match G		0..99	50		System	-	
Cam Match R		0..99	50		System	-	
Cam Match B		0..99	50		System	-	
Cam Match Y		0..99	50		System	-	
Cam Match R-Y		0..99	50		System	-	
Cam Match B-Y		0..99	50		System	-	

MONITORING Menu						
Menu text	User	Values	Default	Blocked if	File	Comments
Monitoring Source	<input type="radio"/> <input type="checkbox"/>	CVBS,R,G,B,Y,Seq, Sup,Ext1,Ext2, YExt1,YExt2	CVBS	-	Scene	Select signal on Monitoring output
Auto Skin Win Ins	<input type="radio"/> <input type="checkbox"/>	On,Off	On	-	Operator	Superimposed information at Monitoring output during Auto Skin process. Not available with LDK10(p) and LDK20(p)
Auto White Win Ins	<input type="radio"/> <input type="checkbox"/>	On,Off	On	-	Operator	Superimposed information at Monitoring output during Auto White process. Not available with LDK10(p) and LDK20(p)
Menu >>						
Display	<input type="radio"/> <input type="checkbox"/>	On,Time	Time	-	Operator	Time out superimposed menu text on or off
Contrast	<input type="radio"/> <input type="checkbox"/>	0...99	50	-	System	Menu text contrast at CVBS and Text output
Menu Time	<input type="radio"/> <input type="checkbox"/>	5...99	10	-	Operator	Time out duration superimposed menu text
CVBS Output	<input type="radio"/> <input type="checkbox"/>	On,Off	Off	-	Operator	Menu text superimposed at CVBS output
Monitor output	<input type="radio"/> <input type="checkbox"/>	On,Off	On	-	Operator	Menu text superimposed at Monitoring output
Menu Level	<input type="radio"/> <input type="checkbox"/>	Oper,Inst	Inst	-	-	Set menu level to Operator or Install level
Statusbar >>						
Studio >>						
Studio	<input type="radio"/> <input type="checkbox"/>	On,Off	Off	-	Operator	Display studio name in Statusbar
Name	<input type="radio"/> <input type="checkbox"/>	[String]	-	-	-	Edit studio name
Operator >>						
Operator	<input type="radio"/> <input type="checkbox"/>	On,Off	Off	-	Operator	Display camera operator name in statusbar
Name	<input type="radio"/> <input type="checkbox"/>	[String]	-	-	-	Edit camera operator name
Camera Number	<input type="radio"/> <input type="checkbox"/>	On,Off	Off	-	Operator	Display camera number in statusbar
Cable Length	<input type="radio"/> <input type="checkbox"/>	On,Off	Off	-	Operator	Display remaining cable length in statusbar
Auto Lighting	<input type="radio"/> <input type="checkbox"/>	On,Off	Off	-	Operator	Display Auto lighting in statusbar

AUDIO/INTERCOM Menu						
Menu text	User	Values	Default	Blocked if	File	Comments
Audio >>						
Audio Level 1	<input type="checkbox"/> <input type="checkbox"/>	0dB,6dB	6dB	-	System	Studio audio system level input 1
Audio Level 2	<input type="checkbox"/> <input type="checkbox"/>	0dB,6dB	6dB	-	System	Studio audio system level input 2
Intercom >>						
Private Data >>						Consult Section "Private Data" for detailed information
Tracker Channel	<input type="checkbox"/> <input type="checkbox"/>	Inter,Priva	Inter		System	Private data channel from Camera to Base Station *
Prog Channel	<input type="checkbox"/> <input type="checkbox"/>	Inter,Priva	Inter	-	System	Private data channel from Base Station to Camera *
Isolate >>						No Intercom communication from Camera to Base Station (Studio)
Source	<input type="radio"/> <input type="checkbox"/>	Local,Rmote	Local	-	Operator	Local = Setting available in Base Station Menu, Rmote = Setting available with MCP
Isolate	<input type="checkbox"/> <input type="checkbox"/>	Isol,Syst	Syst	Source=Rmote	Install	Isol = Isolate, Syst = Isolate is off

AUDIO/INTERCOM Menu (Continued)						
Menu text	User	Values	Default	Blocked if	File	Comments
ENG >>						
Wire Mode	I	2 wire,4 wire	4 wire	-	System	Standard studio intercom system setting
Side Tone level	O I	0..99 0dB,6dB	50 6dB	- ENG Wire Mode=2	Operator	- Standard studio intercom system setting
In Ref Level	I	0..99	50	-	System	Input intercom level fine adjustment (from studio)
Out Ref Level	O I	0..99	50	-	Operator	Output intercom level fine adjustment (to studio)
PROD >>						
Wire Mode	I	2 wire,4 wire	4 wire	-	System	Standard studio intercom system setting
Side Tone	I	0..99	50	-	System	-
Level	O I	0dB,6dB	6dB	PROD Wire Mode=2	Operator	Standard studio intercom system setting
In Ref Level	I	0..99	50	-	System	Input intercom level signal from studio
Out Ref Level	I	0..99	50	-	System	Output intercom level to studio
PROG >>						
Wire Mode	I	2 wire,4 wire	4 wire	-	System	Standard studio intercom system setting
Level	O I	0dB,6dB	6dB	PROG Wire Mode=2	Operator	Standard studio intercom system setting
In Ref Level	I	0..99	50	-	System	Input intercom level signal from studio
ENG Headset >>						Settings for the optional headset module
Phantom Power	O I	On,Off	Off	-	Operator	12V DC Phantom power
Mic Level	O I	0dB,20dB	20dB	-	Operator	Headset microphone gain
Side Tone	O I	0..99	50	-	Operator	Headset side ton level
Mic to Headset	I	On,Off	On	ENG Wire Mode=2	System	Side tone on/off
CAM to Headset	O I	On,Off	On	-	Operator	Camera mic channel to headset
CAM Volume	O I	0..99	50	-	Operator	Camera mic channel to headset level
Tracker to Headset	O I	On,Off	On	-	Operator	Tracker mic channel to headset
Tracker Volume	O I	0..99	50	-	Operator	Tracker mic channel to headset level
Mic Eng-Out	O I	On,Off	On	-	Operator	Headset mic to basestation ENG output
Mic to Eng-Cam	O I	On,Off	On	-	Operator	Headset mic to camera ENG channel
Call	I	Call,Voice	Call	-	Operator	Set to Voice if Voice Mail functionality is required. (The Call function is still available if Call is set to Voice)
Voice Mail >>						See Section "Voice Mail"
Record ENG	O I	On,Off	On	Call is not Voice	Operator	Intercom messages from the ENG channel to the camera are recorded.
Record PROD	O I	On,Off	On	call is not Voice	Operator	Intercom messages from the PROD channel to the camera are recorded.
Record PROG	O I	On,Off	On	call is not Voice	Operator	Intercom messages from the PROG channel to the camera are recorded.

* The LDK 100 and LDK 200 cameras with LDK5430 triax adapter follow these settings automatically.
For the LDK 10(p), LDK 20(p) and LDK 2000(p) cameras dip- switches in the camera have to be set.

SYSTEM Menu						
Menu text	User	Values	Default	Blocked if	File	Comments
Cable >>						
Size	O I	8,11,14	8	-	System	Select triax cable diameter to calculate the maximum triax extension.
Length	O I	0..5000	-	-	-	Maximum triax extension.
Transmission Mode	I	GRB,YRyBy	YRyBy	-	-	Maximum triax extension.
Camera Number	O I	1..15	15	-	-	Set camera number
Camera Power	O I	On,Off	On	-	Operator	Switch the power to the camera
MCP Available	I	Yes,No	Yes	-	Operator	See Section "No MCP Available"
Monitor Mode	I	WFM,Bus	WFM	-	System	See Section "Monitor Mode"
TV System >>						
Auto Lock	I	Yes,No	Yes	-	System	TV System is set by TV System of supplied video at Reference Video Input
TV System	I	NTSC,PAL	PAL	Auto Lock=Yes	System	
TP/Aux Video	I	TP/Aux	TP	-	System	Only available with LDK5430 triax adapter
Analog Options >>						
Video Output	I	GRB,YRyBy,CVBS	GRB	-	System	Select signal type at the Options outputs
Sync >>						Add sync to analog video outputs
Sync in Y	I	On,Off	On	-	-	-
Sync in G	I	On,Off	On	-	-	-
Sync in RB	I	On,Off	Off	-	-	-
Timing						
H Phase Course	O I	0..99	50	No ext. Ref.	System	No external reference signal is provided at the reference input connector.
H Phase Fine	O I	0..99	50	No ext. Ref.	System	See comments H Phase Course
Subcarrier Course	O I	0,90,180,270	180	No ext. Ref.	System	See comments H Phase Course
Subcarrier Fine	O I	0..99	50	No ext. Ref.	System	See comments H Phase Course
Subc H Phase Course	I	0,90,180,270	180	Ext. Ref	System	A external reference signal is provided at the reference input connector
Subc H Phase Fine	I	0..99	50	Ext. Ref	System	See comments Subc H Phase Course
Head Timing	I	0..99	50	-	System	See comments Subc H Phase Course
Clock >>						
Day	I	1..31	1	-	-	-
Month	I	Jan,Feb..Dec	Jan	-	-	-
Year	I	0..99	0	-	-	-
Hour	I	0..23	0	-	-	-
Minute	I	0..59	0	-	-	-

FILES Menu					
Menu text	User	Values	Default	Blocked if	Comments
User Operator Files >>					The "File" column of a menu item indicated with "Operator" is stored in a Operator file.
Operator File	O	O_BS1..O_BS4	BS1		Select Operator file
Recall	O	exec	-		Recall Operator file
Store	O	exec	-		Store Operator file
Std. Operator Files >>					Standard Operator files
Operator File	O	CUST,FACT	CUST		Set the standard Operator file to customer or to factory.
Recall	O	exec	-		Recall standard Operator file
Store		exec	-	Std. Operator file=FACT	Store standard customer Operator file. It is not possible to overwrite the factory file
User System Files >>					The "File" column of a menu item indicated with "System" is stored in a System file.
System File		S_BS1..S_BS4	-		Select System file
Recall		exec	-		Recall System file
Store		exec	-		Store System file
Std. System Files >>					Standard System files
System File		CUST,FACT	CUST		Set the standard System file to customer or to factory.
Recall		exec	-		Recall standard System file
Store		exec	-	Std. System file=FACT	Store standard customer System file. It is not possible to overwrite the factory file

DIAGNOSTICS Menu						
Menu text	User	Values	Default	Blocked if	File	Comments
Board ID >>						
Power Board	0 1				-	-
HP/LP Board	0 1				-	-
Sync/Encoder Board	0 1				-	-
Data Board	0 1				-	-
Video Receiver Board	0 1				-	-
Front End Board	0 1				-	-
Transm. Output Board	0 1				-	-
Audio/Intercom Board	0 1				-	-
External Video Board	0 1				-	-
Monitoring Board	0 1				-	-
FM Transceiver Board	0 1				-	-
Analog Comp Board	0 1				-	-
Aux Receiver Board	0 1				-	-
DSC Interface Board	0 1				-	-
ENG Headset Board	0 1				-	-
Local Power Board	0 1				-	-
Board Diagnostics >>						
Power Board >>					-	
Triax Status	0 1	DCPWR..ACODC	-	-	-	See Section "Triax Status Indications"
Local Power Status	0 1	Ok,NotOK	-	-	-	-
Power Overheated	0 1	Yes,No	-	-	-	-
Fan	0 1	Ok,NotOK	-	-	-	-
Sync/Encoder Board >>						
Sync/Encoder Status	0 1	Ok,NotOK	-	-	-	-
Reference Available	0 1	Yes,No	-	-	-	-
Reference Norm	0 1	NTSC,PAL	-	-	-	-
TV System	0 1	PAL,NTSC	-	-	-	-
Hor. Sync lock	0 1	Yes,No	-	-	-	-
Burst Lock	0 1	Yes,No	-	-	-	-
EXT1 Analog	0 1	None,NTSC,PAL,?	-	-	-	-
EXT2 Analog	0 1	None,NTSC,PAL,?	-	-	-	-
656 Bus Available	0 1	Yes,No	-	-	-	-
TP Available	0 1	Yes,No	-	-	-	-
Data Board >>						
Boot Software Id	0 1	0..255	-	-	-	-
Base Station 12NC	0 1	0..9999	-	-	-	-
Base Station Status	0 1	0..255	-	-	-	-
Video Receiver Board >>						
Video Format Detect	0 1	GRB,YRyBy,ERROR	-	-	-	-
Aux Receiver Board >>						
Carrier Detected	0 1	Yes,No	-	-	-	-
Trans. Output Board >>						
Cam Video Available	0 1	Yes,No	-	-	-	-
H&V Ref Available	0 1	Yes,No	-	-	-	-
Camera Lock	0 1	Yes,No	-	-	-	-
Video Start Calibr	0 1	exec				
Video Calibr Status	0 1	Run,Ready,Fail	-	-	-	Start video calibration by executing the Video Start Calibr status
Transm Output Status	0 1	OK,Fail	-	-	-	-
Audio/Intercom Board >>						
Self test	0 1	exec	-	-	-	-
ENG Test Tone Intern	0 1	Run,OK,Error	-	-	-	-
PROD Test Tone Intern	0 1	Run,OK,Error	-	-	-	-
PROG Test Tone Intern	0 1	Run,OK,Error	-	-	-	-
ENG Test Tone Studio	0 1	Run,OK,Error	-	-	-	-
PROD Test Tone Studio	0 1	Run,OK,Error	-	-	-	-

DIAGNOSTICS Menu						
Menu text	User	Values	Default	Blocked if	File	Comments
ENG Headset Board >>						
Self test	O I	exec	-	-	-	-
Test Intern	O I	Run,OK,Error	-	-	-	-
Test Studio	O I	Run,OK,Error	-	-	-	-
Test Tone Mic. BS	O I	On,Off				
Test Tone Tr/Flr.Mic	O I	On,Off	-	-	-	-
Test Tone Cam.Mic	O I	On,Off	-	-	-	-
Communications Diag. >>						
Camera Connected	O I	Yes,No	-	-	-	-
OCP Connected	O I	Yes,No	-	-	-	-
MCP Connected	O I	Yes,No	-	-	-	-

List of System Menu Functions

Function	Path in Menu
656 Bus Available	Diagnostics \ Board Diagnostics \ Sync/Encoder Board
Analog Comp Board	Diagnostics \ Board
Audio Level 1	Audio/Intercom \ Audio
Audio Level 2	Audio/Intercom \ Audio
Audio/Intercom Board	Diagnostics \ Board ID
Auto Lock TV System	System \ TV System
Auto Skin Win Ins	Monitoring
Auto White Win Ins	Monitoring
Aux Rec Board	Diagnostics \ Board ID
Base Station 12NC	Diagnostics \ Board Diagnostics
Base Station Status	Diagnostics \ Board Diagnostics
Board Diagnostics	Diagnostics \ Board Diagnostics
Board ID	Diagnostics \ Board ID
Boot Software Id	Diagnostics \ Board Diagnostics \ Data Board
Burst Lock	Diagnostics \ Board Diagnostics \ Sync/Encoder Board
Cable Length	System \ Cable
Cable Length	Monitoring \ Statusbar
Cable Size	System \ Cable
Call	Audio/Intercom \ Intercom
Cam Video Available	Diagnostics \ Board Diagnostics \ Trans. Output Board
Camera Connected	Diagnostics \ Communications Diag.
Camera Lock	Diagnostics \ Board Diagnostics \ Trans. Output Board
Camera Number	System \ Camera Number
Camera Number in Status Bar	Monitoring \ Status Bar
Camera Power	System \ Camera Power
Carrier Detected	Diagnostics \ Board Diagnostics \ Aux Receiver Board
Chroma	Video \ Chroma
Clock	System \ Clock
Colour Bar	Video \ Colour Bar
Colour Bar White Bar Level	Video \ Colour Bar
Customer File	Files \ ..
CVBS Menu Output	Monitoring \ Menu
Data Board	Diagnostics \ Board ID
Date	System \ Clock
Day	System \ Clock
Display Time	Monitoring \ Menu
DSC Interf Board	Diagnostics \ Board ID
ENG Headset	Diagnostics \ Board ID
Board	Diagnostics \ Board ID
CAM to Headset	Audio/Intercom \ Intercom \ ENG Headset
CAM Volume	Audio/Intercom \ Intercom \ ENG Headset
Mic Level	Audio/Intercom \ Intercom \ ENG Headset
Mic Norm Level	Audio/Intercom \ Intercom \ ENG Headset
Mic to ENG-Cam	Audio/Intercom \ Intercom \ ENG Headset
Mic to ENG-OUT	Audio/Intercom \ Intercom \ ENG Headset
Mic to Headset	Audio/Intercom \ Intercom \ ENG Headset
Phantom Power	Audio/Intercom \ Intercom \ ENG Headset
Side Tone	Audio/Intercom \ Intercom \ ENG Headset
Tracker to Headset	Audio/Intercom \ Intercom \ ENG Headset
Tracker Volume	Audio/Intercom \ Intercom \ ENG Headset
ENG	Diagnostics \ Board ID
In Ref Level	Audio/Intercom \ Intercom \ ENG
Level	Audio/Intercom \ Intercom \ ENG
Out Ref Level	Audio/Intercom \ Intercom \ ENG
Side Tone	Audio/Intercom \ Intercom \ ENG
Test Tone Detect	Diagnostics \ Board Diagnostics \ Audio/Intercom Board
Wire Mode	Audio/Intercom \ Intercom \ ENG
EXT1 Analog	Diagnostics \ Board Diagnostics \ Sync/Encoder Board
EXT2 Analog	Diagnostics \ Board Diagnostics \ Sync/Encoder Board
External Video Board	Diagnostics \ Board ID
Factory File	Files \ ..
FM Transceiver Board	Diagnostics \ Board ID

Function	Path in Menu
Front End Board	Diagnostics \ Board ID
Generator Lock	Diagnostics \ Board Diagnostics \ Sync/Encoder Board
H Phase Course	System \ Timing
H Phase Fine	System \ Timing
H&V Ref Available	Diagnostics \ Board Diagnostics \ Trans. Output Board
Head Timing	System \ Timing
Headset	
CAM to Headset	Audio/Intercom \ Intercom \ ENG Headset
CAM Volume	Audio/Intercom \ Intercom \ ENG Headset
Tracker to Headset	Audio/Intercom \ Intercom \ ENG Headset
Tracker Volume	Audio/Intercom \ Intercom \ ENG Headset
Mic Level	Audio/Intercom \ Intercom \ ENG Headset
Mic Norm Level	Audio/Intercom \ Intercom \ ENG Headset
Mic to ENG-Cam	Audio/Intercom \ Intercom \ ENG Headset
Mic to ENG-OUT	Audio/Intercom \ Intercom \ ENG Headset
Mic to Headset	Audio/Intercom \ Intercom \ ENG Headset
Phantom Power	Audio/Intercom \ Intercom \ ENG Headset
Side Tone	Audio/Intercom \ Intercom \ ENG Headset
Hour	System \ Clock
Hor. Sync lock	Diagnostics \ Board Diagnostics
HP/LP Filter Board	Diagnostics \ Board ID
Intercom	
In Ref Level	Audio/Intercom \ Intercom \ ...
Isolate	Audio/Intercom \ Intercom \ Isolate
Isolate Source	Audio/Intercom \ Intercom \ Isolate
Level	Audio/Intercom \ Intercom \ ...
Out Ref Level	Audio/Intercom \ Intercom \ ...
Test	Audio/Intercom \ Intercom \ Test
Test routing	Audio/Intercom \ Intercom \ Test
Test Tone Detect	Diagnostics \ Board Diagnostics \ Audio/Intercom Board
Isolate	Audio/Intercom \ Intercom \ Isolate
Isolate Source	Audio/Intercom \ Intercom \ Isolate
Local Power Board	Diagnostics \ Board ID
Local Power Status	Diagnostics \ Board Diagnostics \ Power Board
MCP Available	System \ MCP Available
MCP Connected	Diagnostics \ Board Diagnostics \ Communications
Menu	Monitoring \ Menu
Menu CVBS Output	Monitoring \ Menu
Menu Monitor Output	Monitoring \ Menu
Menu Time	Monitoring \ Menu
Minute	System \ Clock
Monitor Menu Output	Monitoring \ Menu
Monitor Mode	System
Monitoring Board	Diagnostics \ Board ID
Monitoring Source	Monitoring
Month	System \ Clock
Name in Status Bar	Monitoring \ Status Bar
Notch	Video
OCP Connected	Diagnostics \ Board Diagnostics \ Communications
Operator files	Files \ ...
Power Board	Diagnostics \ Board ID
Power Overheated	Diagnostics \ Board Diagnostics \ Power Board
Power Status	Diagnostics \ Board Diagnostics \ Power Board
Private Data	Audio/Intercom \ Intercom \ Private Data
PROD	
In Ref Level	Audio/Intercom \ Intercom \ PROD
Level	Audio/Intercom \ Intercom \ PROD
Out Ref Level	Audio/Intercom \ Intercom \ PROD
Side Tone	Audio/Intercom \ Intercom \ PROD
Test Tone Detect	Diagnostics \ Board Diagnostics \ Audio/Intercom Board

Function	Path in Menu
Wire Mode	Audio/Intercom \ Intercom \ PROD
PROG	
In Ref Level	Audio/Intercom \ Intercom \ PROG
Level	Audio/Intercom \ Intercom \ PROG
Test Tone Detect	Diagnostics \ Board Diagnostics \ Audio/Intercom Board
Wire Mode	Audio/Intercom \ Intercom \ PROG
Record ENG Voice Mail	Audio/Intercom \ Intercom \ Voice Mail
Record PROD Voice Mail	Audio/Intercom \ Intercom \ Voice Mail
Record PROG Voice Mail	Audio/Intercom \ Intercom \ Voice Mail
Reference Available	Diagnostics \ Board Diagnostics \ Sync/Encoder Board
Reference Norm	Diagnostics \ Board Diagnostics \
Saturation	Video \ Saturation
Status Bar	Monitoring
Studio in Status Bar	Monitoring
Subc H Phase Course	System \ Timing
Subc H Phase Fine	System \ Timing
Subcarrier Course	System \ Timing
Subcarrier Fine	System \ Timing
Sync/Encoder Board	Diagnostics \ Board ID
Sync/Encoder Status	Diagnostics \ Board Diagnostics \ Sync/Encoder Board
System files	Files \ ...
Teleprompter	System \ TP/Aux Video
Test	Audio/Intercom \ Intercom \ Test
Time	System \ Clock
Timing	System \ Timing
TP/Aux Video	System
TP Available	Diagnostics \ Board Diagnostics \ Sync/Encoder Board
Transm. Output Board	Diagnostics \ Board ID
Transm Output Status	Diagnostics \ Board Diagnostics \ Trans. Output Board
Triax Status	Diagnostics \ Board Diagnostics \ Power Board
TV System	System
TV System	Diagnostics \ TV System
User Operator File	Files \ User Operator Files
User System File	Files \ User System Files
Video Calibr Status	Diagnostics \ Board Diagnostics \ Trans. Output Board
Video Format Detect	Diagnostics \ Board Diagnostics \ Video Receiver Board
Video Output	System
Video Rec Board	Diagnostics \ Board ID
Voice Mail	Audio/Intercom \ Intercom
White Bar Level	Video \ Colour Bar
Wire Mode	Audio/Intercom \ Intercom \ ...
Year	System \ Clock

List of Abbreviations

Abbreviation	Meaning
adap	adapter
agc	automatic gain control
awb	automatic white balance
bal	balance
cam	camera
ch	channel
cont	contour
ctemp	colour temperature
ctl	control track longitudinal
cus	customer
df	drop frame
dyn	dynamic
exec	execute
exp	exposure
ext	external
ext	extended
flt	filter
fr	front
frm	frame
f-run	free run
hd	head
hr	hour
ind	indicator
info	information
interv	interview
intv	interview
ir	infra-red
lvl	level
man	manual
max	maximum
mic	microphone
min	minute
min	minimum
mom	momentary
mon	monitor
nam	non-additive mix

Abbreviation	Meaning
nd	neutral density
ndf	no drop frame
ocam	camera operator file
ocard	smart card operator file
op	operation
oper	operator
outp	output
ovl	overload
pin	personal identification
number	
r/w	read/write
re	rear
repl	replay
r-run	record run
rst	reset
sawt	sawtooth
scam	camera scene file
scard	smart card scene file
sec	second
sel	select
srch	search
st	stereo
std	standard
str	stretch
tc	time code
tm	timer
ub	user bits
unbal	unbalanced
und	underload
var	variable
ver	version
vert	vertical
vf	viewfinder
wa	wide angle
wh	white
wrn	warning
wrx	wireless receiver

Section 4

Replacements

This section gives information on the procedures to follow when replacing printed circuit boards and mechanical components at first line level.

Contents

Introduction	4-2	Opening The Base Station	4-4
Power	4-2	Replacing Dust Filters	4-5

Introduction

The instructions given in this section are restricted to those modules which can be replaced at the first line service level. These modules include:

- The printed circuit boards
- The connector boards
- The front panels

After a printed circuit board has been replaced it is sometimes necessary to carry out adjustments to match the new boards to your base station and so maintain the performance levels. The relevant adjustment procedures are given in Section 4.

The procedures for removing the modules should be followed in reverse order when remounting the units.

Power

Removing the Power Unit

Remove the screw at the rear of the power unit. With your thumb push up the lever, as shown on the picture below, and pull the Power Unit out of the Base Station.

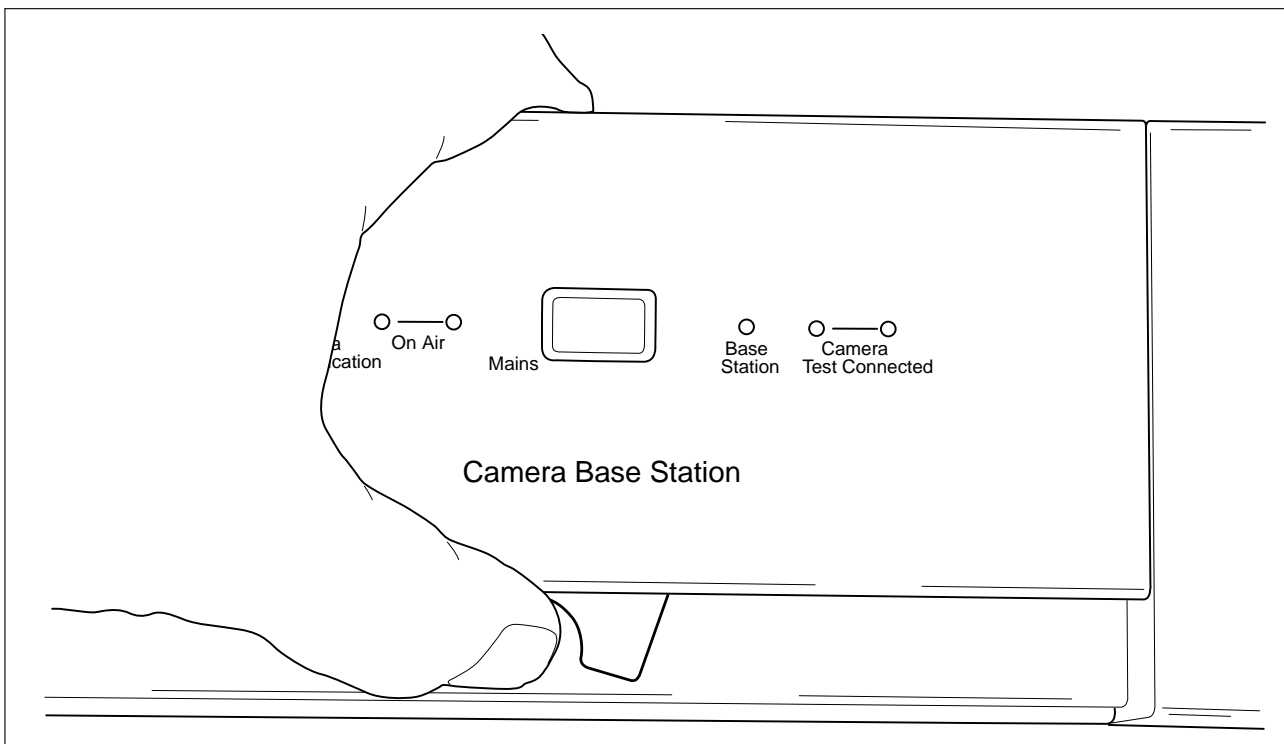

Locking the Power Unit

Put the Power Unit in the leading and push the Power in the Base Station till the locking clicks.

Check if the Power Unit is correct locked.

The correct and wrong locking positions are shown in the pictures below.

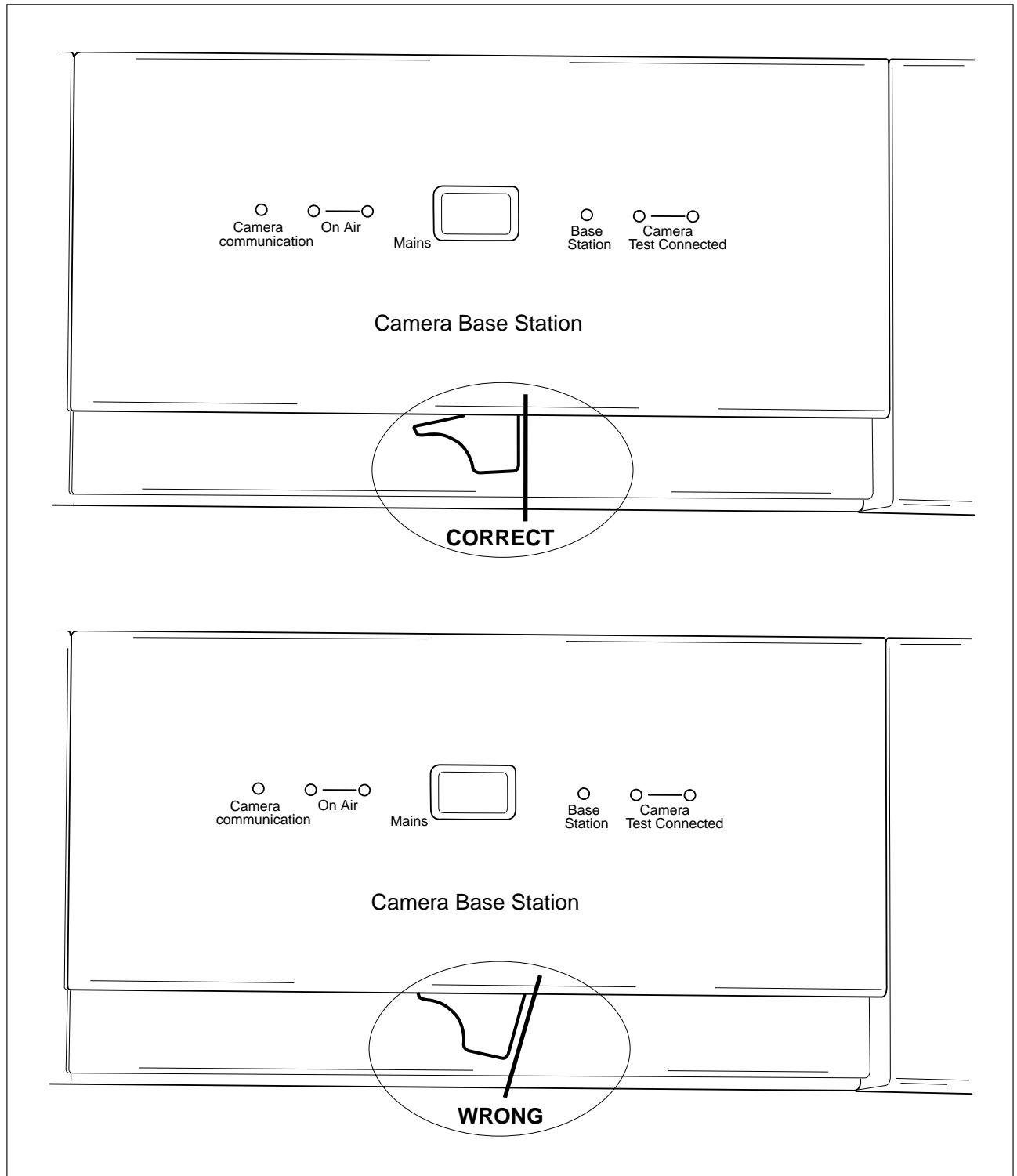

Opening The Base Station

House with top mounted

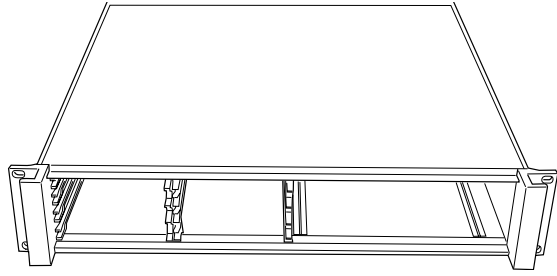

To remove top, bend both sides outwards and lift backside as shown on the picture

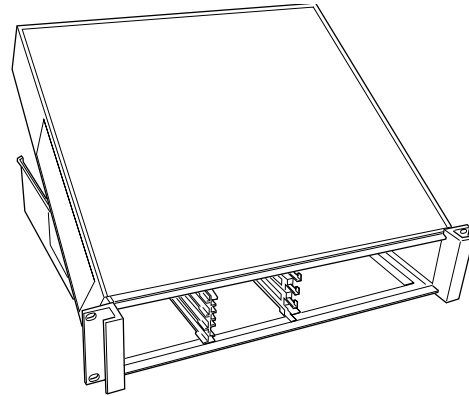

Slide top backwards and lift from house

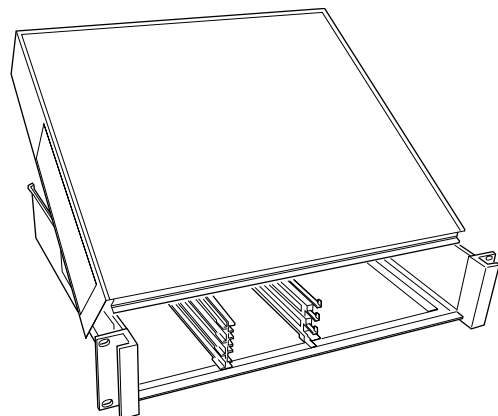

Replacing Dust Filters

Side-inlet

1. Remove 4 screws.
2. Slide back support with dust filter out of base station.

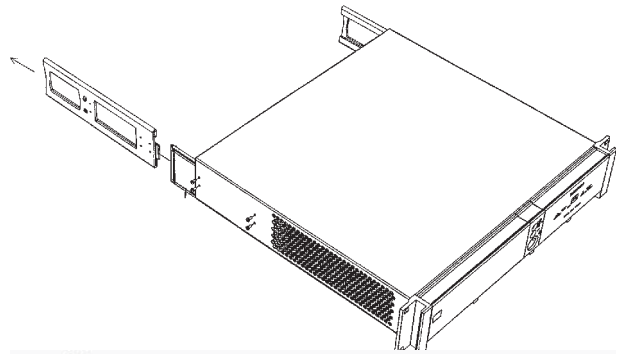

3. Remove dust filter.
4. Connect clean dust filter to back support



5. Slide back support with dust filter into base station
6. Fix back support with 4 screws

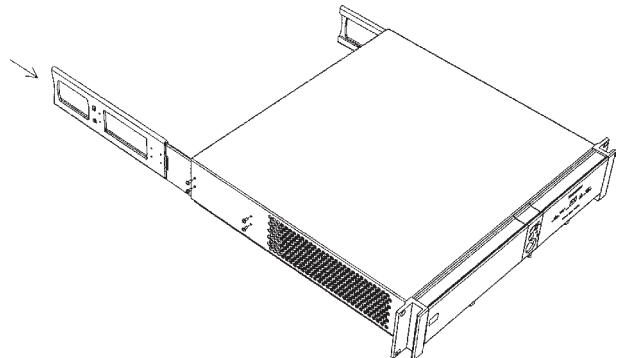

Front-inlet

1. Remove PCB frontplate.

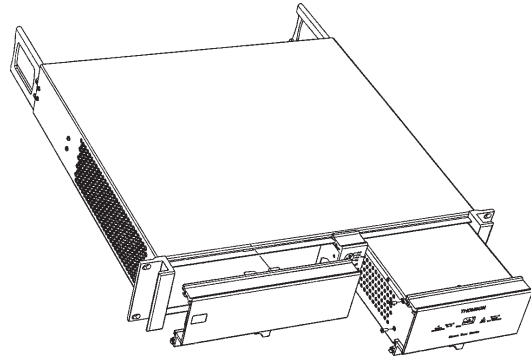

2. Remove dust filter.

3. Place clean dust filter

4. Place PCB frontplate back

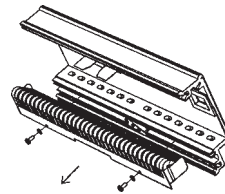

5. Remove frontplate power supply

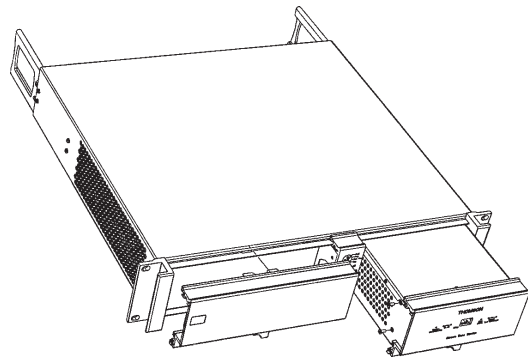

6. Remove dust filter

7. Place clean dust filter

8. Place front plate power supply back

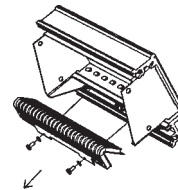

Section 5

Adjustments

This section contains the adjustment procedures to be followed to obtain the best performance from the base station. These procedures need only be used if, following a module replacement, the base station does not perform according to specifications.

Contents

Introduction	5-2
Gain Adjustments Sync Encoder Board	5-3

Introduction

This base station is factory tested and adjusted for operational use. Under normal circumstances, the internal automatic calibration procedures do not need to be started and the internal potentiometers do not need to be adjusted.

There is only one situation that might require some realignment of the base station: When a printed circuit board has been replaced.

If it is discovered that the base station is misaligned, the following procedures are given as a guide for competent service personnel, who have a thorough knowledge of the base station and have the use of calibrated equipment, to realign the base station.

If no improvement can be achieved or an adjustment is out of range, please contact your local supplier or the nearest Philips Service Centre.

The base station adjustment procedures are designed as separate units. Within a numbered procedure do not change the position of switches or jumpers unless instructed to do so in the procedure.

Gain Adjustments Sync Encoder Board

Test Equipment

- Oscilloscope
- Waveform monitor / Vectorscope

Caution

Follow all steps and complete the gain adjustment procedure to avoid misadjustments.

note: All Base station menu items necessary for the Gain adjustments are located in the Base station *Video \ Gain Adjustments \ Consult manual first* menu.

If gain adjustments are required proceed as follows:

Preparation

- Select in the Base station menu the standard Customer or Factory file. *Base station Menu: Recall Std. System File - CUST or FACT.*
- Recall standard system file. *Base station Menu: Recall Std. Sys File - exec*
- Set the Colour Bar to On. *Base station Menu: Colour Bar - On.*
- Set White Bar Level to 100%. *Base station Menu: White Bar Level - 100%*
- Supply a black burst video signal to the Reference input of the Base station.

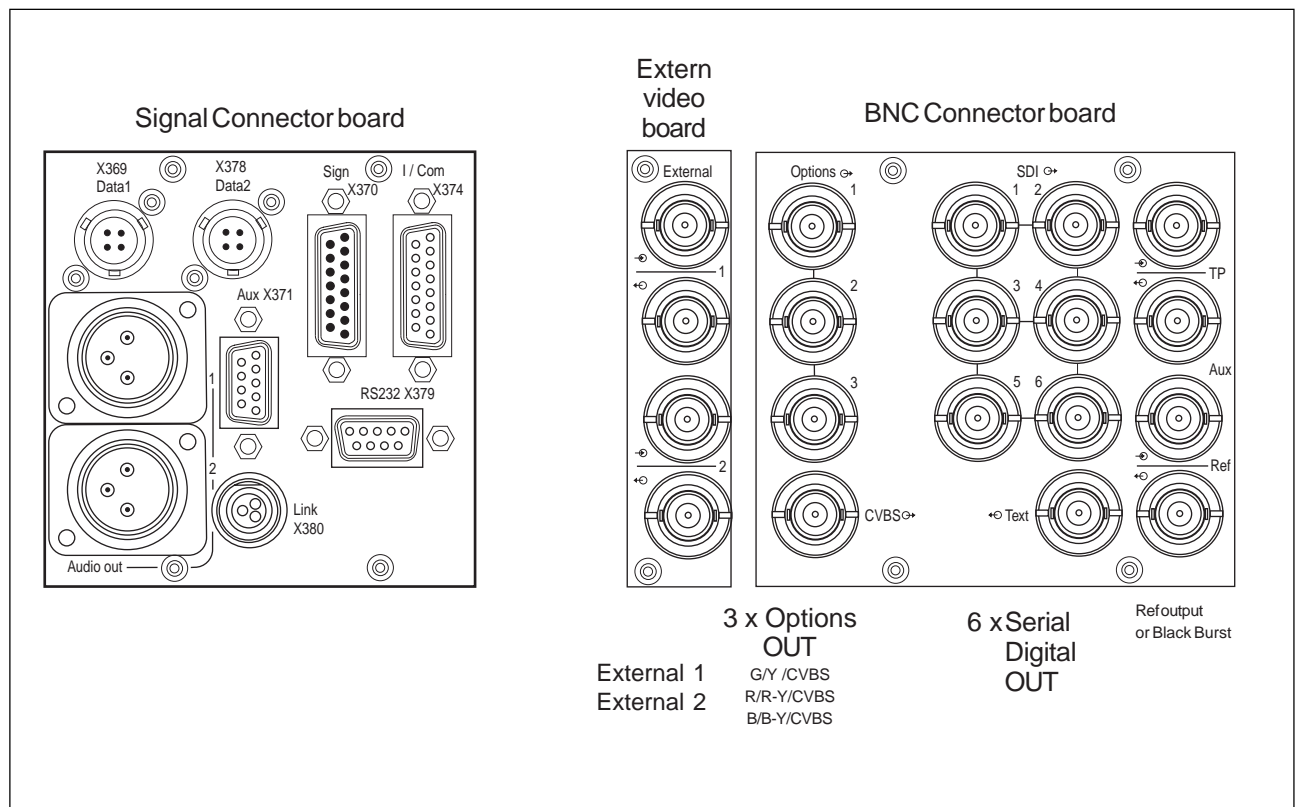

Section 6

Diagnostics

This section contains an explanation of the internal diagnostic system of the base station. The diagnostic messages and the block diagrams are a useful help when fault finding.

Contents

Diagnostic LED Indications	6-2	Fault finding chart	6-5
Triax diagnostic indications	6-3	Sync/Encoder board status	6-6
Board identification	6-4		

Diagnostic LED Indications

LED Test

When the power to the Base Station is switched on camera communication and on-air LEDs light sequentially. If a LED does not light during start-up that LED is probably defective.

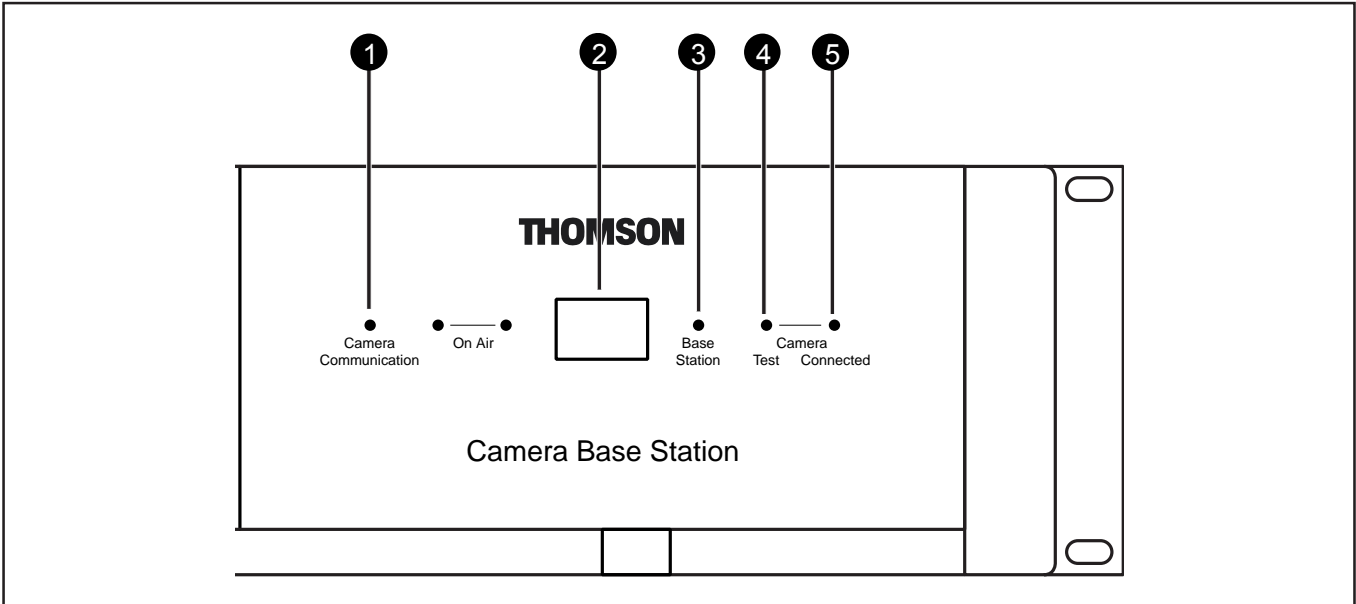

1 Camera Communication

This green LED lights when the communications between Camera and Base Station are OK.

2 Power Switch and indicator

Switches the power supply to the Base Station on and off. A built-in light lights to indicate that power is being supplied to the Base Station.

3 Base Station

This green LED lights when the local power supplies to the Base Station are present.

4 Camera indicator - Test

This bicolour TEST LED lights red or yellow to indicate the Camera and Triax status:

- Red lights continuously – Triax short circuit.
- Red flashes – Triax open circuit.
- Yellow – Camera power switched off with the Operational or Master Control Panel.

5 Camera indicator - Connected

This green CONNECTED LED lights when the Camera is connected and the Camera power is not switched off by the MCP, OCP or Base Station menu.

Diagnostic indicators for camera power

Communication	Test	Connected	
off	off	green	Camera power switched off by the camera power switch.
off	yellow	off	Camera power switched off by the MCP, OCP or base station menu.

Triax diagnostic indications

Camera test LED (4) flashes red

A red flashing camera test LED (4) indicates an open triax connection (no camera is connected). Other indicators of this condition are:

OCP: Triax LED Flashes red
MCP: *DIAGNOSE \ TRIAX - OPEN*
Menu: *Diagnostics \ Communications \ Camera Connected -No*

Camera test LED (4) lights continuously (red)

A continuously lighting red camera test LED (4) indicates a short circuit in the triax connection (or an interrupted inner core). Other indicators of this condition are:

OCP: Triax LED red (continuously)
MCP: *DIAGNOSE \ TRIAX - SHORT*
Menu: *Diagnostics \ Board Diagnostics \ Power board \ Triax Status -TSHRT, COPEN or CSHRT (The interpretation of these messages is shown below)*

COPEN

Indicates a connection between outer and inner shield or between core and outer shield (when a camera is not connected).

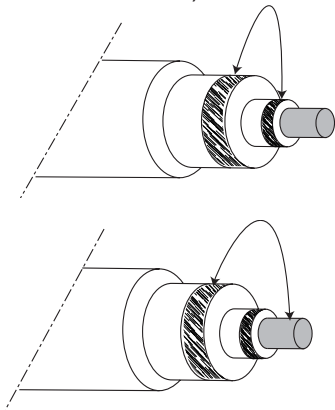

It also indicates an interrupted inner core when both shields are connected correctly (when a camera is connected).

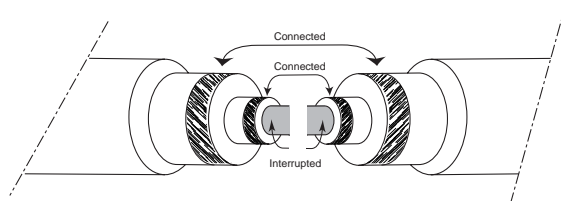

CSHRT

Indicates a short circuit between the core and the inner shield.

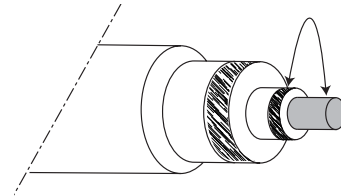

TSHRT

Indicates a short circuit between the inner shield, the outer shield and the core.

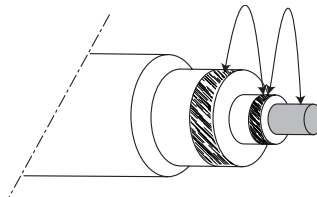

SOPEN

Indicates an open connection in the outer shield of the Triax cable or connector(s).

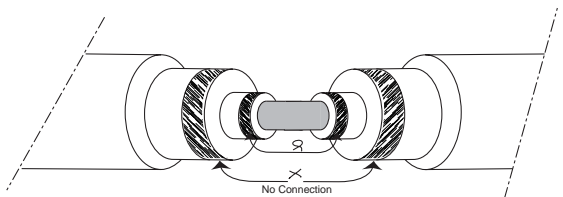

Precautions to avoid Triax problems

- Only use triax cable (with three conductors).
- Ensure that triax connectors (camera, CPU and extension cables) fit snugly into each other.
- Verify that there is no interruption in all three conductors of the triax cable before deploying (including extension triax cables).

Board identification

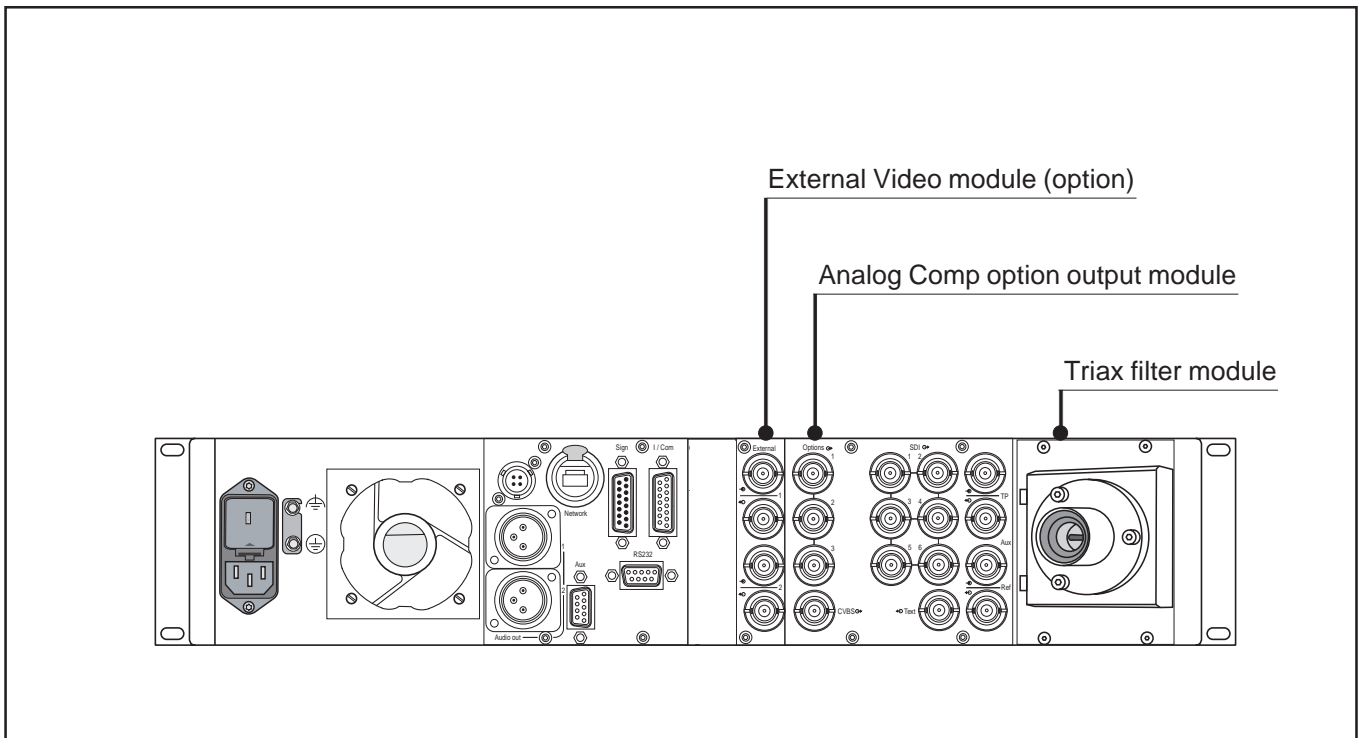
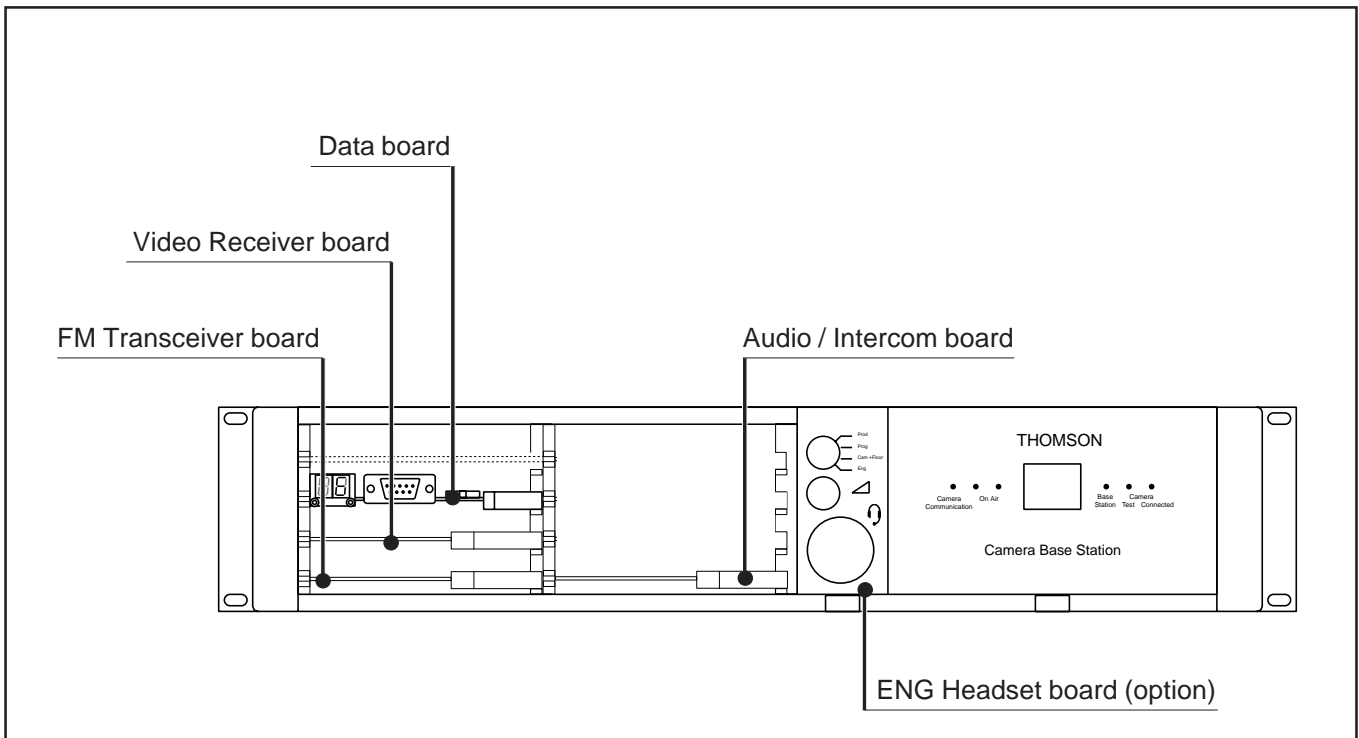

Fault finding chart

This chart shows a simple systematic approach to locating a fault in the base station. Always check the connections first. You can check the operation of a board by swapping it with another of the same type. Use the explanation of the diagnostic LEDs on the previous page to interpret triax and power problems.

