

# 8921DAC

4-CH AUDIO D-A CONVERTER WITH DELAY

Instruction Manual

SOFTWARE VERSION 1.0.0

071821401  
JULY 2004

*the most watched worldwide*

# Contacting Grass Valley

Region	Voice	Fax	Address	Web Site
North America	(800) 547-8949 Support: 530-478-4148	Sales: (530) 478-3347 Support: (530) 478-3181	Grass Valley P.O. Box 599000 Nevada City, CA 95959-7900 USA	www.thomsongrassvalley.com
Pacific Operations	+852-2585-6688 Support: 852-2585-6579	+852-2802-2996		
U.K., Asia, Middle East	+44 1753 218 777	+44 1753 218 757		
France	+33 1 45 29 73 00			
Germany, Europe	+49 6150 104 782	+49 6150 104 223		

Copyright © Thomson Broadcast and Media Solutions All rights reserved.

## Grass Valley Web Site

The [www.thomsongrassvalley.com](http://www.thomsongrassvalley.com) web site offers the following:

**Online User Documentation** — Current versions of product catalogs, brochures, data sheets, ordering guides, planning guides, manuals, and release notes in .pdf format can be downloaded.

**FAQ Database** — Solutions to problems and troubleshooting efforts can be found by searching our Frequently Asked Questions (FAQ) database.

**Software Downloads** — Software updates, drivers, and patches can be downloaded.

# *Preface*

## **About This Manual**

This manual describes the features of a specific module of the Gecko 8900 Signal Processing System. As part of this module family, it is subject to Safety and Regulatory Compliance described in the Gecko 8900 Series frame and power supply documentation (see the *8900TX/8900TF/8900TFN Frames Instruction Manual*).



# Contents

- Preface**..... 3
  - About This Manual ..... 3
  
- 8921DAC 4-Channel Audio D-A Converter**
  - Introduction ..... 7
  - Installation ..... 8
    - Module On-board Jumper Settings..... 8
    - Frame Capacity ..... 9
    - Module Placement in the Gecko 8900 Audio Frame ..... 9
    - Cabling ..... 10
      - Audio Inputs..... 10
      - Audio Outputs ..... 11
  - Power Up ..... 12
    - Operation Indicator LEDs ..... 13
  - Configuration..... 14
    - Configuration Summary..... 14
      - Audio Channel Pairing ..... 14
      - Audio Delay ..... 14
      - Audio Processing..... 14
      - Maximum Audio Analog Output Levels ..... 16
    - Local Onboard Module Configuration..... 19
      - Configuration Switches and Controls..... 19
      - 8921DAC Module Onboard Configuration Settings..... 20
    - Remote Configuration and Monitoring ..... 23
      - 8921DAC Links and Web Pages ..... 25
        - Status Web Page..... 26
        - I/O Config Web Page ..... 27
        - Functional View Web Page..... 28
        - Module Configuration Web Pages ..... 29
          - E-MEM Web Page ..... 34
          - Slot Config Page..... 37
          - Software Update Page..... 39
      - Newton Control Panel Configuration ..... 40
    - Specifications ..... 41
    - Service..... 43
    - Status Monitoring ..... 44
      - LEDs ..... 44
      - Frame Alarm ..... 45
      - Web Browser Interface ..... 45
      - SNMP Reporting ..... 46
  
  - Index** ..... 47



# *8921DAC 4-Channel Audio D-A Converter*

## **Introduction**

The 8921DAC provides conversion of two digital audio streams (balanced or unbalanced) to four balanced processed analog audio channels and four balanced buffered AES outputs. In addition to conversion, it offers independent delay controls for each channel to compensate for external video processing.

The 8921DAC features the following:

- Two AES digital audio inputs with:
  - Support of both balanced (110  $\Omega$ ) and unbalanced inputs (75  $\Omega$ ) AES input stream
  - Presence and error detection on each input pair
  - Sample rate support of 32 kHz to 96 kHz
  - Auto-detection of emphasis (50/15) with status report
  - Sample word length of up to 24 bits
- Four balanced analog audio outputs with:
  - 24-bit DAC D-to-A conversion
  - Independent control of each analog audio channel including:
    - Channel pairing
    - Level adjustment
    - Swapping, summation, phase inversion
    - Delay up to 5.4 seconds
    - Test tone generation
- Four buffered balanced AES outputs as two groups of two AES streams for AES input dual distribution (without reclocking),
- Remote web browser and Newton Control Panel interface with the 8900NET module.

# Installation

Installation of the 8921DAC module is a process of:

1. Setting on-board jumpers for desired input formats,
2. Placing the module in the proper audio frame slot, and
3. Cabling and terminating signal ports.

The 8921DAC module can be plugged in and removed from a Gecko 8900 audio frame with power on. When power is applied to the module, LED indicators reflect the initialization process (see [Power Up](#) on page 12).

## Module On-board Jumper Settings

The on-board jumpers shown in [Figure 1](#) must be set for the following:

- Local/Remote operation – set jumper J2 to LOC (pins 1-2) to lock out remote control or LOC/REM (pins 2-3) for both local and remote control.
- AES 1 and AES 2 input format – the input format for AES 1 and AES 2 must be set to either balanced (pins 2-3) or unbalanced (pins 1-2) with jumpers J9 (AES 2 – IN) and J10 (AES 1 – IN) depending on the input format desired.

Figure 1. On-Board Jumper Locations

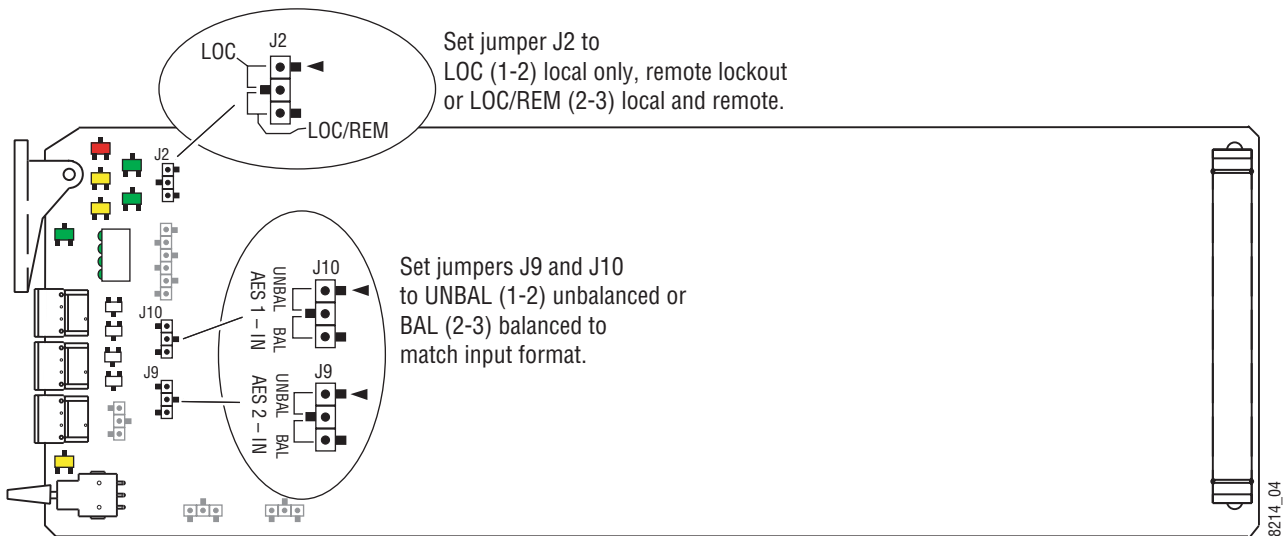



## Frame Capacity

The 8921DAC module can be installed in all Gecko 8900 audio frames but with varying maximum quantities determined by frame cooling capacity. [Table 1](#) provides the power capacity, cooling capacity, and maximum module count for each frame type.

Table 1. Audio Frame Power Capacity

Capacity Calculated	8900TX Frame	8900TF Frame	8900TFN Frame
Power (W)	100	100	100
Recommended Module Cooling (W)	30	90	90
8921DAC Modules	4	10	10

**Note** Module capacity figures assume no other modules are in the frame.  
X = Not recommended without forced air cooling.

## Module Placement in the Gecko 8900 Audio Frame

There are ten cell locations in the audio frame to accommodate audio modules. These are the left ten locations. Refer to [Figure 2](#).

The two cells on the right are allocated for the power supplies. For additional information concerning the Power Supply module, refer to the 8900 Power Supply manual.

The third cell from the right is allocated for the Frame Monitor or 8900NET Network Interface module. These modules provide health monitoring and control options.

Figure 2. Gecko 8900 Series Frame

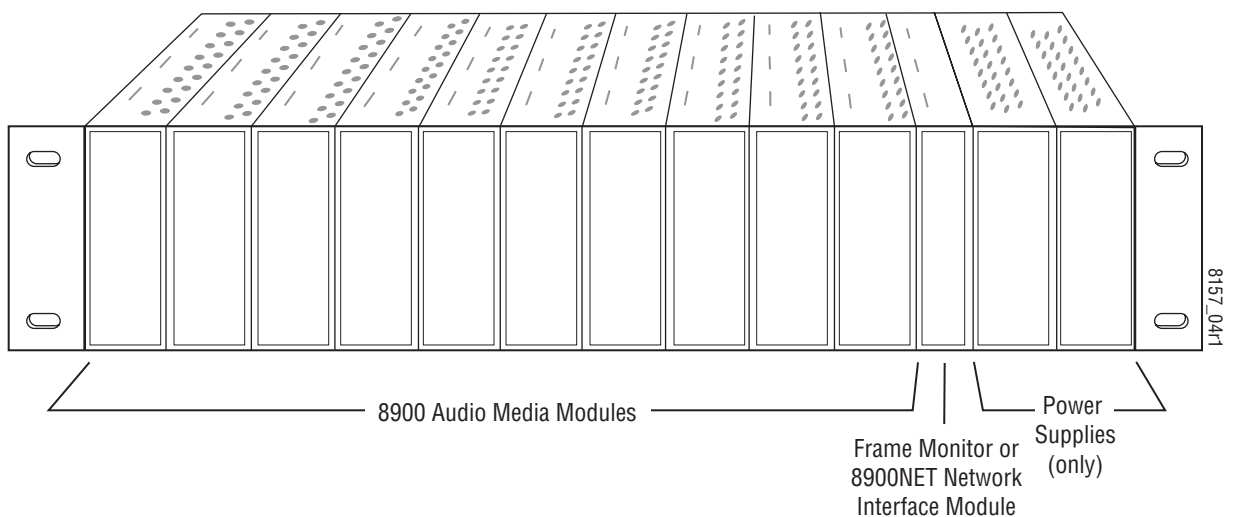

8900 module slots are interchangeable within the frame. There are audio connectors and BNCs in each slot's I/O group. The functional assignment of each connector in a group is determined by the module that is placed in that slot. The maximum number of modules a Gecko 8900 audio frame can accept is ten. [Figure 3](#) illustrates the rear connector plate for a Gecko 8900 audio frame.

Figure 3. Gecko 8900 Series Audio Frame Rear Connector

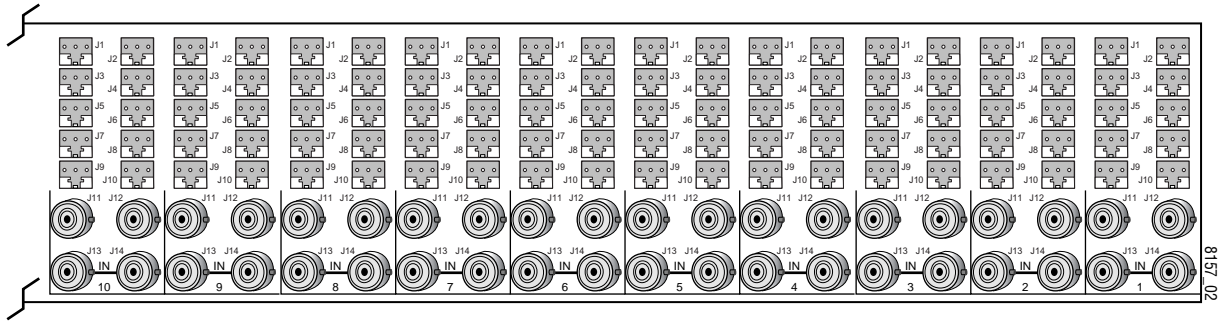

To install a module in the frame:

1. Insert the module, connector end first, with the component side of the module facing to the right and the ejector tab to the top.
2. Verify that the module connector seats properly against the backplane.
3. Press in the ejector tab to seat the module.

## Cabling

Cabling to and from the module is done at the back of the Gecko 8900 audio frame as described below and shown in [Figure 4 on page 11](#). The cabling information is also silkscreened on the back of the circuit board.

### Audio Inputs

AES audio inputs can be balanced or unbalanced. Jumpers on the circuit board must be set for the desired format for AES 1 and AES 2. Refer to [Module On-board Jumper Settings on page 8](#).

#### Unbalanced Inputs

Unbalanced AES inputs are available at BNCs J11 (AES 1 A/B In) and J12 (AES 2 C/D In).

#### Balanced Inputs

Balanced AES inputs are available at three terminal connectors J9 (AES 1 A/B In) and J10 (AES 2 C/D In).

## Audio Outputs

Audio outputs are available in both analog audio and AES formats.

### Analog Audio

There are four high impedance balanced analog audio outputs available from the module at three terminal connectors J1, J2, J3, and J4.

### AES Audio Outputs

Four balanced AES outputs are available at three terminal connectors J5, J6, J7, and J8.

Figure 4. 8921DAC Rear Input/Output Connectors

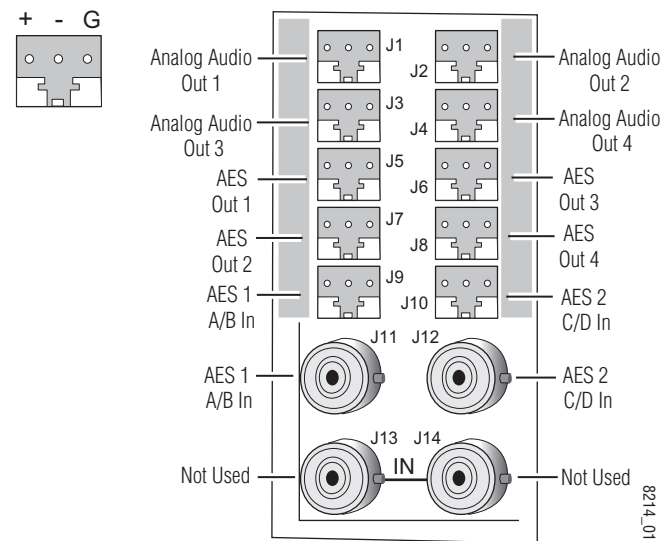

# Power Up

The front LED indicators and configuration switches are illustrated in [Figure 5](#). Upon power-up, the green PWR LED should light and the yellow CONF LED should illuminate for a few seconds for the duration of module initialization.

Figure 5. LEDs and Configuration Switches

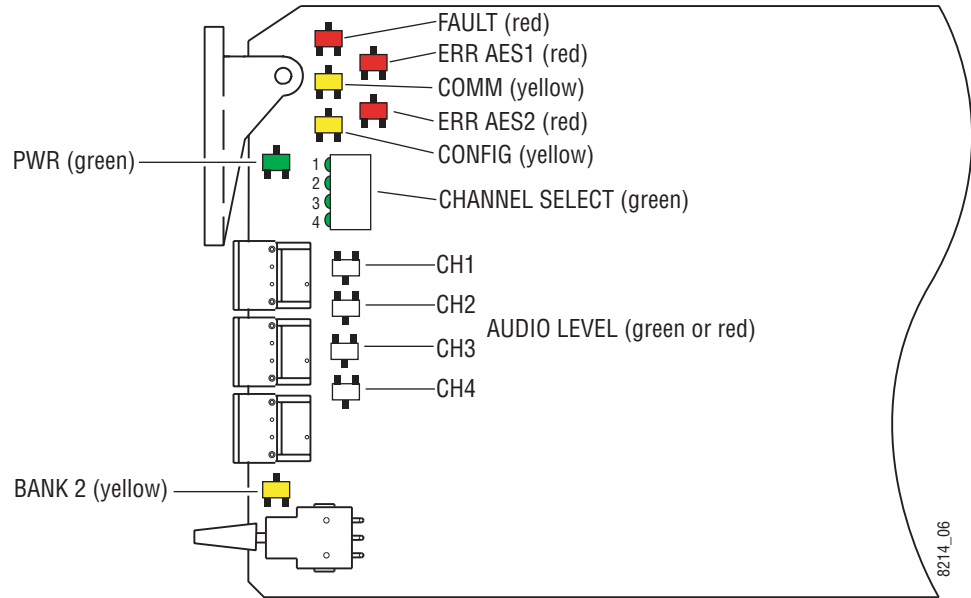

## Operation Indicator LEDs

Refer to [Figure 5 on page 12](#) and [Table 2](#) for the name and meaning of each of the board edge operating indicators on the module circuit board.

Table 2. Board Edge LED Names and Meaning

LED	Indication	Condition
<b>FAULT</b> (red)	Off	Normal operation.
	On continuously	Module has detected an internal fault. (Refer to <a href="#">Service on page 43.</a> )
	Long Flash	User configuration problems. Input missing or not locked. Processor failed to load/configure or diagnostics failed on one or more devices.
<b>COMM</b> (yellow)	Off	No activity on frame communication bus.
	3 Quick Pulses	Locate Module command received by the module from a remote control system.
	Short flash	Activity present on the frame communication bus.
<b>CONFIG</b> (yellow)	Off	Module is in normal operating mode.
	On continuously	Module is initializing, changing operating modes or programming hardware.
	3 Quick Pulses	Locate Module command received by the module from a remote control system.
<b>PWR</b> (green)	Off	No power to module or module's DC/DC converter failed.
	On continuously	Normal operation, module is powered.
<b>ERR AES1</b> (red)	On	No error detected for AES 1 A/B input. SRC A/B ready.
	Off	One of the following errors detected for AES 1 A/B input: CRC, Input not present, PLL AES receiver not locked, Validity Bit set, Non-audio bit set, excessive parity error.
<b>ERR AES2</b> (red)	On	No error detected for AES 2 C/D input. SRC C/D ready.
	Off	One of the following errors detected for AES 2 C/D input: CRC, Input not present, PLL AES receiver not locked, Validity Bit set, Non-audio bit set, excessive parity error.
<b>CH SEL 1-4</b> (green)	Off	Indicated input A-D is not selected for AES output channel selected with CONTROL rotary switch or audio channel 1-4 (after pairing) is not affected by adjustment selected with CONTROL rotary switch.
	On	Indicated input A-D is selected for AES output channel selected with CONTROL rotary switch or audio channel 1-4 (after pairing) is affected by adjustment selected with CONTROL rotary switch.
<b>CH 1-4</b> <b>AUDIO LVL</b> (green or red)	Off	Channel 1-4 Digital processed audio (before DAC) level < -40 dBFS
	Red	Channel 1-4 Digital processed audio (before DAC) level > -40 dBFS but < -0.5 dBFS
	Green	Channel 1-4 Digital processed audio (before DAC) level > -0.5 dBFS
<b>BANK 2</b> (yellow)	Off	Bank 1 of Control rotary switch is active.
	On	Bank 2 of Control rotary switch is active.

# Configuration

The 8921DAC can be configured locally using on-board switches or remotely using the 8900NET network interface GUI or a Newton Control Panel.

Refer to the following sections for configuration instructions:

- Configuration Summary ([page 14](#))
- Local On-board Module Configuration ([page 19](#))
- Remote Control and Monitoring ([page 23](#))
- Newton Control Panel Configuration ([page 40](#))

Operation of these control types is explained in detail in their respective sections of this manual.

## Configuration Summary

This section provides a summary of all parameters that can be configured on the 8921DAC module. Use this section in conjunction with the specific configuration method instructions for each configuration type. [Table 3 on page 17](#) provides a summary in table format of all parameters and their ranges, default values, and remote, local, and control panel function names and locations for setting each value.

### Audio Channel Pairing

The four AES input channels can be arbitrarily recombined (routed) to any of the four analog output channels.

### Audio Delay

Each analog audio output channel can be delayed individually or locked together in two groups. Outputs can be delayed up to 5 seconds.

### Audio Processing

Audio processing can be performed on the four analog outputs to set the the gain of each output channel or channel pair and the output processing mode for each pair.

## Output Processing Modes

Each analog audio output pair (Channel 1/2 and Channel 3/4) can be set to one of the following output modes:

- 1, 2 (Pass) – the inputs selected for Channels 1 and 2 appear at the analog audio output unmodified.
- – 1, – 2 (both phase inverted) – the inputs selected for Channel 1 and 2 are both inverted.
- – 1, 2 (Channel 1 Phase Inverted) – the input selected for Channel 1 is inverted while Channel 2 is non-inverted.
- 1, – 2 (Channel 2 Phase Inverted) – the input selected for Channel 2 is inverted while Channel 1 is non-inverted.
- 1 + 2, (monaural sum) – the inputs selected for Channels 1 and 2 are reduced in level by 6 dB, summed together, and output on both channels.
- 1 + 2, 1 – 2 (MD D/E) – 1 + 2 to Channel 1; 1 – 2 to Channel 2, – 6 dB mono sum to Channel 1 and – 6dB 1 – 2 decode/encode to Channel 2.
- – (1 +2) (1 + 2 to Both and Phase Invert) – the inputs selected for Channels 1 and 2 are reduced in level by 6 dB, summed together, inverted, and output on both channels.
- 1 kHz (Tone) – a 1 kHz tone is put on both channels at the analog audio output with a – 20 dBFS level.
- 400 Hz (Tone) – a 400 Hz tone is put on both channels at the analog audio output with a – 20 dBFS level.
- Silence – digital silence is placed on both output channels.
- 1 + 2, 3 – the two streams chosen for Channels 1 and 2 will be summed and sent to the Channel 1 output. The Channel 3 audio from Analog Outputs 3/4 will be put on the Channel 2 output. In this mode, Analog Audio Outputs 3/4 will pass its inputs for Channels 3 and 4 as selected with the output processing control for Channels 3/4.
- 1 + 2, 4 – the two streams chosen for Channels 1 and 2 will be summed and sent to the Channel 1 output. The Channel 4 audio from Channels 3/4 will be put on the Channel 2 output. In this mode, Analog Audio Outputs 3/4 will pass its inputs for Channels 3 and 4 as selected with the output processing control for Channels 3/4.
- 1/2 ID – 1/2 identification tone. A 1 kHz tone with a – 20 dBFS level that is 2 second continuous tone on Channel 1 followed by a 6 second continuous tone on Channel 2 (keeps repeating).

The Channel 3/4 output can be set to one of the following output modes:

- 3, 4 (Pass) – the inputs selected for Channels 3 and 4 appear at the analog audio output unmodified.
- – 3, – 4 (both phase inverted) – the inputs selected for Channels 3 and 4 are both inverted.
- – 3, 4 (Channel 3 Phase Inverted) – the input selected for Channel 3 is inverted while Channel 4 is non-inverted.
- 3, – 4 (Channel 4 Phase Inverted) – the input selected for Channel 4 is inverted while Channel 3 is non-inverted.
- 3 + 4, (monaural sum) – the inputs selected for Channel 3 and 4 are reduced in level by 6 dB, summed together, and output on both channels.
- 3 + 4, 3– 4 (MD D/E) – 3 + 4 to Channel 1; 3 – 4 to Channel 2, – 6 dB mono sum to Channel 3 and – 6dB 3 – 4 decode/encode to Channel 4.
- – (3 + 4) (3 + 4 to Both and Phase Invert) – the inputs selected for Channels 3 and 4 are reduced in level by 6 dB, summed together, inverted, and output on both channels.
- 1 kHz (Tone) – a 1 kHz tone is put on both channels at the analog audio output with a – 20 dBFS level.
- 400 Hz (Tone) – a 400 Hz tone is put on both channels at the analog audio output with a – 20 dBFS level.
- Silence – digital silence is placed on both output channels.
- 3/4 ID – Channel 3/4 identification tone. A 1 kHz tone with a – 20 dBFS level that is 2 second continuous tone on Channel 3 followed by a 6 second continuous tone on the Channel 4 (keeps repeating).

### Gain Controls

The gain of the four audio outputs can be adjusted from –40 to + 6 dB. Each channel output can be adjusted individually or locked together in two groups (Channel 1/2 and Channel 3/4).

### Maximum Audio Analog Output Levels

Controls are provided for setting the maximum analog audio output levels from 0 to + 24 dBu.



Table 3 provides a complete summary of the 8921DAC functions and a comparison of the functionality available with each control type along with the ranges and default values for each parameter.

Table 3. Summary of 8921DAC Configuration Functions

Function Type	Default	Range/Choices Resolution	Web Page/Function Name	Rotary Switch Bank/Setting	Control Panel Mnemonic	Notes/Conditions
Input to Channel 1	AES1 A	AES1 A AES1 B AES2 A AES2 B	Audio Channel Pairing/ Assign Channel 1	1:7	Ch1 Sel	Route AES inputs to Analog outputs
Input to Channel 2	AES1 B		Audio Channel Pairing/ Assign Channel 2	1:8	Ch2 Sel	
Input to Channel 3	AES2 A		Audio Channel Pairing/ Assign Channel 3	1:9	Ch3 Sel	
Input to Channel 4	AES2 B		Audio Channel Pairing/ Assign Channel 4	1:A	Ch4 Sel	
Delay Channel 1	0 sec	0 - 5.46 sec (2 msec steps)	Audio Delay/ Channel 1 Delay (ms)	2:7	Ch1 Dly	<b>Locked</b> boxes must be unchecked on web pages.
Delay Channel 2			Audio Delay/ Channel 2 Delay (ms)	2:8	Ch2 Dly	
Delay Channel 3			Audio Delay/ Channel 3 Delay (ms)	2:9	Ch3 Dly	
Delay Channel 4			Audio Delay/ Channel 4 Delay (ms)	2:A	Ch4 Dly	
Delay Channel 1/2			Audio Delay/ Channel 1 or 2 Delay (ms) Select <b>Locked</b> checkbox	2:B	N/A	<b>Locked</b> boxes must be checked on web pages.
Delay Channel 3/4			Audio Delay/ Channel 3 or 4 (ms) Select <b>Locked</b> checkbox	2:C		
Gain Channel 1	0 dBu	- 40 to +6 dBu (0.1 dB steps)	Audio Proc/ Channel 1 Gain (dB)	2:3	Ch1 Gain	<b>Locked</b> boxes must be unchecked on web pages.
Gain Channel 2			Audio Proc/ Channel 2 Gain (dB)	2:4	Ch2 Gain	
Gain Channel 3			Audio Proc/ Channel 3 Gain (dB)	2:5	Ch3 Gain	
Gain Channel 4			Audio Proc/ Channel 4 Gain (dB)	2:6	Ch4 Gain	
Gain Channel 1/2			Audio Proc/ Channel 1 or 2 Gain (dB) Select <b>Locked</b> checkbox	2:1	N/A	<b>Locked</b> boxes must be checked on web pages.
Gain Channel 3/4			Audio Proc/ Channel 3 or 4 Gain (dB) Select <b>Locked</b> checkbox	2:2		

Table 3. Summary of 8921DAC Configuration Functions

Function Type	Default	Range/Choices Resolution	Web Page/Function Name	Rotary Switch Bank/Setting	Control Panel Mnemonic	Notes/Conditions
Channel 1/2 Processing	1, 2	1, 2	Audio Proc/ Processing pulldown for J1 and J2	S1 AA 1/2:0	Out1, 2Proc (See Range Choices column)	Set output processing mode for Channel 1/2
		- 1, - 2		S1 AA 1/2:1		
		- 1, 2		S1 AA 1/2:2		
		1, - 2		S1 AA 1/2:3		
		1 + 2 (- 6 dB)		S1 AA 1/2:4		
		1 + 2, 1 - 2		S1 AA 1/2:5		
		- (1 + 2)		S1 AA 1/2:6		
		1 kHz		S1 AA 1/2:7		
		400 Hz		S1 AA 1/2:8		
		Silence		S1 AA 1/2:9		
		1 + 2, 3		S1 AA 1/2:A		
		1 + 2, 4		S1 AA 1/2:B		
		1/2 ID		S1 AA 1/2:E		
Channel 3/4 Processing	3, 4	3, 4	Audio Proc/ Processing pulldown for J3 and J4	S2 AA 3/4:0	Out3,4Proc (See Range Choices column)	Set output processing mode for Channel 3/4
		- 3, - 4		S2 AA 3/4:1		
		- 3, 4		S2 AA 3/4:2		
		3, - 4		S2 AA 3/4:3		
		3 + 4		S2 AA 3/4:4		
		3 + 4, 3 - 4		S2 AA 3/4:5		
		- (3 + 4)		S2 AA 3/4:6		
		1 kHz		S2 AA 3/4:7		
		400 Hz		S2 AA 3/4:8		
		Silence		S2 AA 3/4:9		
		3/4 ID		S2 AA 3/4:E		
Max Level Audio Out 1	+ 24 dBu	0 - + 24 dBu (0.1 dB steps)	Analog Audio Outputs/ Max Output Level 1	1:3	Ch1 OutLvl	<b>Locked</b> boxes must be unchecked on web pages.
Max Level Audio Out 2			Analog Audio Outputs/ Max Output Level 2	1:4	Ch2 OutLvl	
Max Level Audio Out 3			Analog Audio Outputs/ Max Output Level 3	1:5	Ch3 OutLvl	
Max Level Audio Out 4			Analog Audio Outputs/ Max Output Level 4	1:6	Ch4 OutLvl	
Max Level Audio Out 1/2			Analog Audio Outputs/ Max Out put Levels 1 or 2 Select <b>Locked</b> checkbox	1:1	N/A	<b>Locked</b> boxes must be checked on web pages.
Max Level Audio Out 3/4			Analog Audio Outputs/ Max Out put Levels 3 or 4 Select <b>Locked</b> checkbox	1:2		
Recall Factory Defaults	-	See above	E-MEM/ <b>Default</b> button	2:F	N/A	See Default column
Save/Recall User Settings	-	-	E-MEM/ <b>Save</b> or <b>Recall</b> User Settings button	1:E	N/A	

## Local Onboard Module Configuration

The 8921DAC module can be configured and operated locally using the rotary and paddle switches on the front edge of the module ([Figure 6](#)).

Figure 6. Module Jumpers and Switches for Local Configuration

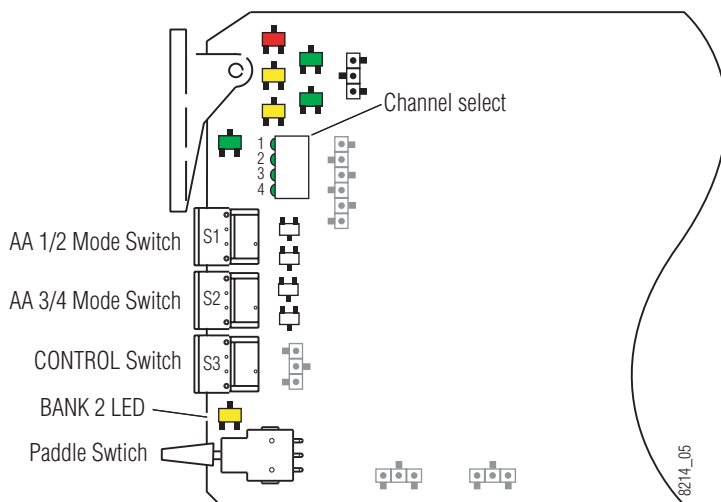

### Configuration Switches and Controls

The switches available for local configuration are described below. Refer to [Figure 6](#) for the following descriptions:

- MODE and CONTROL (rotary) switches — Three rotary hex switches are present on the front edge of the module, AA (Analog Audio) 1/2 MODE, AA 2 MODE, and CONTROL.

The AA 1 and AA 2 MODE rotary switches select the output mode for each analog audio pair from output processing settings. Local settings for each output mode are given in [Table 5 on page 22](#).

The CONTROL switch is used to set the available module parameters in conjunction with the CONTROL paddle switch. It addresses two banks of functions; each bank has 16 possible positions (0 through 9 and A through F). Not all positions are used. The next bank of functions is accessed each time the CONTROL switch makes a complete revolution past zero (or back through F). While in Bank 1, a complete revolution past zero accesses Bank 2; while in Bank 2, a complete revolution past zero accesses Bank 1 again. The yellow BANK 2 LED indicates which bank is currently being accessed.

**Note** The CONTROL rotary switch should be kept in position 0 in any bank (parked) when not in use to avoid any inadvertent change in configuration. Position 0 in each bank is inactive.

- BANK 2 (second Function) yellow LED – when off, indicates that the rotary switch is addressing the first bank of functions. When on, indicates that the rotary switch is addressing the second bank of functions.
- CONTROL (paddle) switch – actuates or selects the desired setting for the selected function when the switch is held momentarily in either the up or down position.
- CONF (configuring) yellow LED – when on, indicates the module is programming hardware.

## 8921DAC Module Onboard Configuration Settings

To make a configuration setting:

1. Rotate the CONTROL rotary switch to Bank 1 (BANK 2 LED off) or Bank 2 (BANK 2 LED on) and to the desired function within that bank according to [Table 4 on page 21](#).
2. Move the paddle switch to the up or down position and hold momentarily to set the desired function (refer to [Table 4 on page 21](#)).

**Note** Holding the paddle switch in the up or down position for more than a half second will automatically accelerate through the value range for parameters with 256 or more values. The full range can be accessed in about 10 seconds.

Table 4. CONTROL Rotary and Paddle Switch Functions

	Rotary Switch Setting	Paddle Switch Up	Paddle Switch Down	Function Description
<b>Bank 1 (BANK 2 LED off)</b>				
<b>Bank 1 (BANK 2 LED off)</b>	0	–	–	Default position for normal operation (paddle disabled).
	1	Increase	Decrease	Adjust maximum output level for Channel 1 and 2 together. <sup>1</sup>
	2	Increase	Decrease	Adjust maximum output level for Channels 3 and 4 together. <sup>1</sup>
	3	Increase	Decrease	Adjust maximum output level for Channel 1 separately.
	4	Increase	Decrease	Adjust maximum output level for Channel 2 separately.
	5	Increase	Decrease	Adjust maximum output level for Channel 3 separately.
	6	Increase	Decrease	Adjust maximum output level for Channel 4 separately.
	7	Increment input #	Decrement input #	Select input AES stream to be used for Channel 1 output.
	8	Increment input #	Decrement input #	Select input AES stream to be used for Channel 2 output.
	9	Increment input #	Decrement input #	Select input AES stream to be used for Channel 3 output.
	A	Increment input #	Decrement input #	Select input AES stream to be used for Channel 4 output.
	B – D	Currently not used (paddle disabled)		
	E	Recall	Save	Save and recall current user settings.
F	Recall	–	See <a href="#">Table 3 on page 17</a> for factory default values	
<b>Bank 2 (BANK 2 LED on)</b>				
<b>Bank 2 (BANK 2 LED on)</b>	0	–	–	Default position for normal operation (paddle disabled).
	1	Increase	Decrease	Adjust output gain of both Channel 1/2 together. <sup>1</sup>
	2	Increase	Decrease	Adjust output gain of both Channel 3/4 together. <sup>1</sup>
	3	Increase	Decrease	Adjust output gain of Channel 1.
	4	Increase	Decrease	Adjust output gain of Channel 2
	5	Increase	Decrease	Adjust output gain of Channel 3.
	6	Increase	Decrease	Adjust output gain of Channel 4.
	7	Increase	Decrease	Adjust delay of Channel 1.
	8	Increase	Decrease	Adjust delay of Channel 2.
	9	Increase	Decrease	Adjust delay of Channel 3.
	A	Increase	Decrease	Adjust delay of Channel 4.
	B	Increase	Decrease	Adjust delay of Channel 1/2 together.
	C	Increase	Decrease	Adjust delay of Channel 3/4 together.
	D-E	Currently not used (paddle disabled)		
F	Recall	–	Recall defaults	

<sup>1</sup> Preserves gain offsets between channels.

### Set Output Processing Modes

Two rotary switches are provided on the front edge of the module for setting the desired output processing mode for Channel 1/2 (AA 1/2 – SW1) and Channel 3/4 (AA 3/4 – SW2). Refer to *Output Processing Modes* on page 15 for an overview of each mode.

Table 5. AA 1/2 and AA 3/4 Mode Switch Settings

Position	Channel 1 Processing Mode	Channel 2 Processing Mode
0	1, 2 (Pass)	3, 4 (Pass)
1	-1, -2	-3, -4
2	-1, 2	-3, 4
3	1, -2	3, -4
4	1 + 2 (-6 dB)	3 + 4 (-6 dB)
5	1 + 2, 1 - 2 (MS D/E)	3 + 4, 3 - 4 (MS D/E)
6	-(1 + 2)	-(3 + 4)
7	1 kHz	1 kHz
8	400 Hz	400 Hz
9	Silence	Silence
A	1 + 2, 3	3, 4
B	1 + 2, 4	3, 4
C	1, 2	3, 4
D	1, 2	3, 4
E	1/2 ID	3/4 ID
F	1, 2	3, 4

## Remote Configuration and Monitoring

8921DAC configuration and monitoring can be performed using a web browser GUI interface when the 8900NET Network Interface module is present in the audio frame (Gecko 8900TFN-A frame). This section describes the GUI access to the module configuration functions. For Newton Control Panel information, refer to *Newton Control Panel Configuration* on page 40.

For remote access, make sure the jumper block on the module is set for both Local and Remote access (*Figure 6* on page 19).

Refer to the *8900NET Network Interface Module Instruction Manual* for information on the 8900NET Network Interface module and setting up and operating the Gecko 8900 frame network.

**Note** For optimal performance and access to the latest features, it is recommended that the 8900NET module be updated to the latest software release. Check the Grass Valley web site for the current 8900NET software.

Refer to the Frame Status web page shown in *Figure 7* on page 24. The 8900 audio modules can be addressed by clicking either on a specific module icon in the frame status display or on a module name or slot number in the link list on the left.

**Note** The physical appearance of the menu displays on the web pages shown in this manual represent the use of a particular platform, browser and version of 8900NET module software. They are provided for reference only. Displays will differ depending on the type of platform and browser you are using and the version of the 8900NET software installed in your system. This manual reflects the use of version 3.2.2 8900NET software.

Use the **Refresh** button to update the display (available with 8900NET software version 3.0 and later).

For information on status and fault monitoring and reporting shown on the Status page, refer to *Status Monitoring* on page 44.

Figure 7. Frame Status Web Page

The Links section lists the frame and its current modules. The selected link's Status page is first displayed and the sub-list of links for the selection is opened. The sub-list allows you to select a particular information page for the selected device.

Content display section displays the information page for the selected frame or module (frame slot icons are also active links).

Refresh button for manual update of page

**Bay 1 QA 8900 Audio**

- [Status](#)
- [Configuration](#)
- [1 8921DAC](#)
- [2 Media Slot 2](#)
- [3 8921DAC](#)
- [4 Media Slot 4](#)
- [5 Media Slot 5](#)
- [6 Media Slot 6](#)
- [7 Media Slot 7](#)
- [8 Media Slot 8](#)
- [9 Media Slot 9](#)
- [10 8920DMX](#)
- [11 8900NET](#)
- [12 Power Supply 1](#)
- [13 Power Supply 2](#)

**Status**

Model: 8900TFN-A Description: Module Frame  
 Frame Location: 8900: QA Bay 1  
 Frame Health Alarm **PASS** Temperature Status **Pass**

Module	Empty	Module	Empty	Empty	Empty	Empty	Empty	Empty	Empty	Module	Net Card	Empty	Power Supply
--------	-------	--------	-------	-------	-------	-------	-------	-------	-------	--------	----------	-------	--------------

Front Cover **No Cover**

**Properties**

Vendor	Thomson, Grass Valley	Software Version	3.2.2
Media Slots	10	Network Config	Network configuration stored on frame

8214\_09



## 8921DAC Links and Web Pages

The 8900 GUI provides the following links and web pages for the 8921DAC module (Figure 8):

- Status – reports input and reference signal status and module information (page 26)
- I/O Config – shows a graphic representation of inputs and outputs to the module (page 27)
- Functional View – shows a block diagram of the module with links to each configuration page (page 28),
- Module Configuration pages for setting up the module (page 29)
- E-MEM – provides Learn and Recall functions for an E-MEM register along with **Save to** and **Load from** file operations (page 34)
- Slot Config – provides a Locate Module function and Slot Memory (page 37)
- Software Update – allows updating of software from a CD-ROM or the web site (page 39)

Figure 8. 8921DAC Web Page Links

### 10 8921DAC

Status

I/O Config

Functional View

- Audio Channel Pairing

- Audio Delay

- Audio Proc

- Analog Audio Outputs

E-MEM®

Slot Config

Software Update

## Status Web Page

Use  
this  
link

- [10 8921DAC](#)
- [Status](#)
- [I/O Config](#)
- [Functional View](#)
- [Audio Channel Pairing](#)
- [Audio Delay](#)
- [Audio Proc](#)
- [Analog Audio Outputs](#)
- [E-MEM@](#)
- [Slot Config](#)
- [Software Update](#)

The Status web page (Figure 9) shows the signal status of the input AES 1 and AES 2 audio, AES outputs, analog audio outputs, and frame bus communication. Color coding of the display indicates the signal status. Refer to *Status Monitoring on page 44* for an explanation of the color coding.

Information about the module, such as part number, serial number, asset tag number, hardware revision and software and firmware versions are given in a read-only section at the bottom of the display. Enabled options are also reported if applicable.

Clicking on the underlined link for AES Input 1, AES Input 2, AES outputs, or Analog Audio Outputs will take you to the I/O Config page.

Clicking on the 8921DAC model number in the center box will take you to the Functional View page illustrating a block diagram overview of the module with links to each of the configuration pages.

Figure 9. 8921DAC Status Page

**Status**

Model: [8921DAC](#) Description: [4 Chan Aud DAC/Dly](#)  
 Frame Location: [Modular Lab](#) , Slot: [1](#)  
 Last Recalled E-MEM: -

### Multi-Channel Module Physical Structure

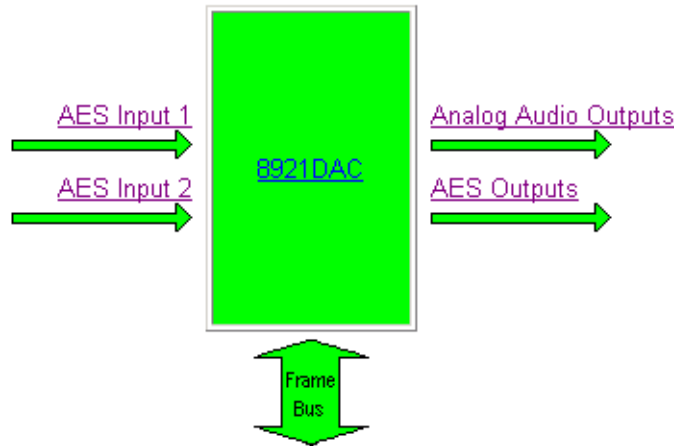

Part Number: <a href="#">671-6497-00A</a>
Serial Number: <a href="#">1234</a>
Hardware Revision: <a href="#">00A</a>
Firmware Version: <a href="#">1.0.0</a>
Software Version: <a href="#">1.0.0</a>
Asset Tag: <a href="#">LAB-1234</a>

## I/O Config Web Page

- Use this link
- [10 8921DAC](#)
  - [Status](#)
  - [I/O Config](#)
  - [Functional View](#)
  - [Audio Channel Pairing](#)
  - [Audio Delay](#)
  - [Audio Proc](#)
  - [Analog Audio Outputs](#)
  - [E-MEM@](#)
  - [Slot Config](#)
  - [Software Update](#)

The I/O Config web page (Figure 10) shows the rear input and output connections to the module. Audio input and output status is reported by the color-coding of the corresponding blocks. Refer to *Web Browser Interface* on page 45 for a complete explanation of status reporting.

Reporting of status for each input and output can be enabled or disabled by checking or unchecking the corresponding **Enabled** checkbox. Disabling reporting will turn the corresponding box gray as shown in the example for Audio Out 3 in Figure 10.

**Note** Enabling an AES input is effective for both the 3-pin connector and the BNC.

Figure 10. 8921DAC I/O Config Web Page



Model: 8921DAC Description: 4 Chan Aud DAC/Dly  
 Frame Location: Modular Lab , Slot: 1  
 Last Recalled E-MEM: -

### Rear Connections

Reporting							Reporting
<input checked="" type="checkbox"/> Enabled	Audio Out 1	J1			J2	Audio Out 2	<input checked="" type="checkbox"/> Enabled
<input type="checkbox"/> Enabled	Audio Out 3	J3			J4	Audio Out 4	<input checked="" type="checkbox"/> Enabled
<input checked="" type="checkbox"/> Enabled	AES Out 1	J5			J6	AES Out 3	<input checked="" type="checkbox"/> Enabled
<input checked="" type="checkbox"/> Enabled	AES Out 2	J7			J8	AES Out 4	<input checked="" type="checkbox"/> Enabled
<input checked="" type="checkbox"/> Enabled	AES In 1 A/B	J9			J10	AES In 2 C/D	<input checked="" type="checkbox"/> Enabled
<input checked="" type="checkbox"/> Enabled	AES In 1 A/B	J11			J12	AES In 2 C/D	<input checked="" type="checkbox"/> Enabled
	not used	J13			J14	not used	

+ - G

Three pins connector usage:



## Functional View Web Page

- Use this link
- [10 8921DAC](#)
  - [Status](#)
  - [I/O Config](#)
  - [Functional View](#)
  - [Audio Channel Pairing](#)
  - [Audio Delay](#)
  - [Audio Proc](#)
  - [Analog Audio Outputs](#)
  - [E-MEM®](#)
  - [Slot Config](#)
  - [Software Update](#)

The Functional View web page (Figure 11) illustrates a block diagram of the 8921DAC module showing module functions and signal paths that are active or inactive in the current configuration. It can be used as a link map for configuring module functions.

Color coding indicates active functions and signal flow. Grayed components are inactive due to hardware and/or software constraints. Underlined module functions are links to the web page for that function.

Use the Functional View to configure the 8921DAC module in the order of the signal flow. Refer to each of the module configuration web pages given in the next section.

Figure 11. 8921DAC Functional View Web Page

### **Functional View**

Model: [8921DAC](#) Description: 4 Chan Aud DAC/Dly  
Frame Location: [Modular Lab](#) , Slot: 1  
Last Recalled E-MEM: -

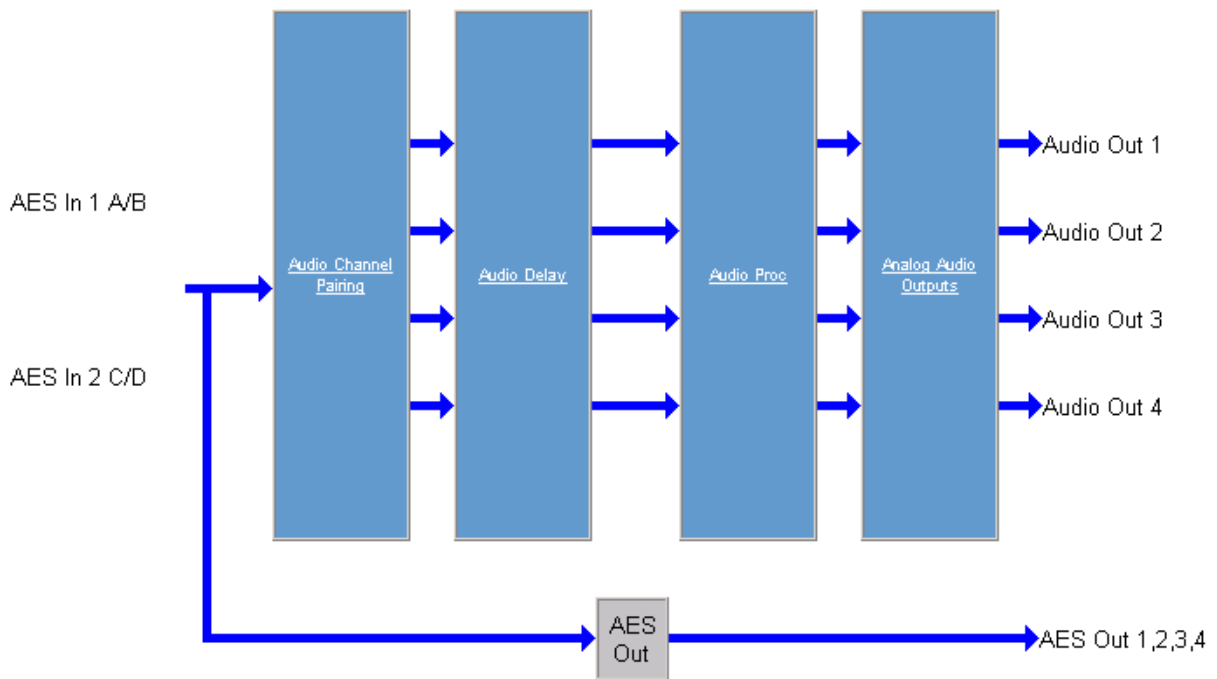

## Module Configuration Web Pages

Module configuration is provided for the following functions with the GUI interface:

- Audio Channel Pairing ([page 30](#))
- Audio Delay ([page 31](#))
- Audio Proc ([page 32](#))
- Analog Audio Outputs ([page 33](#))

Read-only information about the module is given on the top of each page including model name and description, frame and slot location and last E-MEM register recalled.

After making a parameter value change, click on **Apply** to activate settings in each selection.

Select the **Back**, **Functional View**, or **Next** link to navigate to the next function or use the links on the left of the web page.

Click on the **Refresh** button at the top of the display to update the entire display.

- Use this link
- [10 8921DAC](#)
  - [Status](#)
  - [I/O Config](#)
  - [Functional View](#)
  - [Audio Channel Pairing](#)
  - [Audio Delay](#)
  - [Audio Proc](#)
  - [Analog Audio Outputs](#)
  - [E-MEM®](#)
  - [Slot Config](#)
  - [Software Update](#)

### Audio Channel Pairing Web Page

The Audio Channel Pairing web page (Figure 12) allows routing the four AES audio input streams to be output on any of the four analog audio output channels 1, 2, 3, and 4.

Assign each AES input audio stream from the list on the left to Channel 1, 2, 3, or 4 by clicking on the corresponding radio button under the channel number. The default routing (AES 1 A to Channel 1, AES1 B to Channel 2, AES2 A to Channel 3, and AES2 B to Channel 4) is shown in the example.

Figure 12. 8921DAC Audio Channel Pairing Web Page

**Audio Channel Pairing**

Model: 8921DAC Description: 4 Chan Aud DAC/Dly  
 Frame Location: Modular Lab , Slot: 1  
 Last Recalled E-MEM: -

**Input Stream Select**

	Audio Pairing			
Channel	1	2	3	4
AES In 1 A	<input checked="" type="radio"/>	<input type="radio"/>	<input type="radio"/>	<input type="radio"/>
AES In 1 B	<input type="radio"/>	<input checked="" type="radio"/>	<input type="radio"/>	<input type="radio"/>
AES In 2 C	<input type="radio"/>	<input type="radio"/>	<input checked="" type="radio"/>	<input type="radio"/>
AES In 2 D	<input type="radio"/>	<input type="radio"/>	<input type="radio"/>	<input checked="" type="radio"/>

[Back](#) [Functional View](#) [Next](#)

### Audio Delay Web Page

The Audio Delay web page (Figure 13) provides delay controls for the Analog Audio output channels.

Use this page to do the following:

- Use this link
- [10 8921DAC](#)
  - [Status](#)
  - [I/O Config](#)
  - [Functional View](#)
  - [Audio Channel Pairing](#)
  - [Audio Delay](#)
  - [Audio Proc](#)
  - [Analog Audio Outputs](#)
  - [E-MEM@](#)
  - [Slot Config](#)
  - [Software Update](#)

- Set delay for each output channel with the Delay controls at the bottom of the page.
- Channel 1 and 2 and Channel 3 and 4 can also be adjusted in pairs by selecting the corresponding **Locked** checkbox in the Delay Locking areas for each channel pair. When locked, selecting either channel control in the pair will change the amount of delay for both channels by the same amount.

Figure 13. 8921DAC Audio Delay Web Page



Model: 8921DAC Description: 4 Chan Aud DAC/Dly  
 Frame Location: Modular Lab , Slot: 1  
 Last Recalled E-MEM: -

Audio Delay				
Channel	1	2	3	4
Selection	AES In 1 A	AES In 1 B	AES In 2 C	AES In 2 D
Delay Locking	<input type="checkbox"/> Locked		<input type="checkbox"/> Locked	
Delay	<< Delay (mS) 0 >> < Apply >	<< Delay (mS) 0 >> < Apply >	<< Delay (mS) 0 >> < Apply >	<< Delay (mS) 0 >> < Apply >

[Back](#)
[Functional View](#)
[Next](#)

### Audio Proc Web Page

The Audio Proc web page (Figure 14) reports the following for each output channel:

- Presence of processed audio output signal (True = > -40 dBFS)
- Clip status of processed audio output signal (True = > -0.5 dBFS)

Use the Audio Proc page to make the following adjustments:

- Gain – adjust the output gain in dB for each channel with the corresponding **Gain** controls.  
Gains can also be adjusted in pairs (Channel 1 and 2, Channel 3 and 4) by selecting the corresponding **Locked** checkbox in the Gain Locking area and adjusting either **Gain** control in the pair. Gain offsets between channels are preserved for each channel (except when the limits are reached).
- Processing – set the output processing mode for Analog Audio Out Channel 1/2 (rear connectors J1 and J2) and Analog Audio Out Channel 3/4 (rear connectors J3 and J4) from the corresponding Processing pull-down. Refer to *Output Processing Modes* on page 15 for an overview of each output processing mode.

- Use this link
- [10 8921DAC](#)
  - [Status](#)
  - [I/O Config](#)
  - [Functional View](#)
  - [Audio Channel Pairing](#)
  - [Audio Delay](#)
  - [Audio Proc](#)
  - [Analog Audio Outputs](#)
  - [E-MEM®](#)
  - [Slot Config](#)
  - [Software Update](#)

Figure 14. 8921DAC Audio Proc Web Page



Model: [8921DAC](#) Description: [4 Chan Aud DAC/Dly](#)  
 Frame Location: [Modular Lab](#) , Slot: [1](#)  
 Last Recalled E-MEM: -

Audio Processing				
Channel	1	2	3	4
Selection	<a href="#">AES In 1 A</a>	<a href="#">AES In 1 B</a>	<a href="#">AES In 2 C</a>	<a href="#">AES In 2 D</a>
Presence	<a href="#">True</a>	<a href="#">True</a>	<a href="#">True</a>	<a href="#">True</a>
Clip	<a href="#">False</a>	<a href="#">False</a>	<a href="#">False</a>	<a href="#">False</a>
Gain Locking	<input type="checkbox"/> Locked		<input type="checkbox"/> Locked	
Gain	Gain (dB) << 0.0 >> < Apply >	Gain (dB) << 0.0 >> < Apply >	Gain (dB) << 0.0 >> < Apply >	Gain (dB) << 0.0 >> < Apply >
Processing	J1  1.2  J2	J3  3.4  J4		

Note: Presence ==> -40 dBFS, Clip ==> -0.5 dBFS

[Back](#)

[Functional View](#)

[Next](#)



### Analog Audio Outputs Web Page



Use the Analog Audio Outputs web page (Figure 15) to set the maximum output levels for Audio Out 1 – 4:

- Max Output Level – adjust the maximum output level in dBu for each channel with the corresponding **Max Output Level** controls.

Output levels can also be adjusted in pairs (Channel 1 and 2, Channel 3 and 4) by selecting the corresponding **Locked** checkbox in the Max Output Locking area and adjusting either **Max Output Level** control in the pair. Level offsets between channels are preserved for each channel (except when the limited are reached).

- Use this link
- 10 8921DAC
  - Status
  - I/O Config
  - Functional View
    - Audio Channel Pairing
    - Audio Delay
    - Audio Proc
    - Analog Audio Outputs
    - E-MEM@
    - Slot Config
    - Software Update

Figure 15. 8921DAC Analog Audio Outputs Web Page

 **Analog Audio Outputs** 

Model: 8921DAC Description: 4 Chan Aud DAC/Dly

Frame Location: Modular Lab , Slot: 1

Last Recalled E-MEM: -

Connector	J1	J2	J3	J4
Function	Audio Out 1	Audio Out 2	Audio Out 3	Audio Out 4
Max Output Locking	<input type="checkbox"/> Locked		<input type="checkbox"/> Locked	
Max Output Levels	Max Output Level (dBu) << 24.0 >> < Apply >	Max Output Level (dBu) << 24.0 >> < Apply >	Max Output Level (dBu) << 24.0 >> < Apply >	Max Output Level (dBu) << 24.0 >> < Apply >

[Back](#) [Functional View](#) [Next](#)

## E-MEM Web Page

- [10 8921DAC](#)
- [Status](#)
- [I/O Config](#)
- [Functional View](#)
- [Audio Channel Pairing](#)
- [Audio Delay](#)
- [Audio Proc](#)
- [Analog Audio Outputs](#)
- [E-MEM®](#)
- [Slot Config](#)
- [Software Update](#)

Use  
this  
link

The E-MEM web page (Figure 16) provides local operations for learning and recalling the current user configuration. File operations are also available for saving or loading the saved files to and from a hard disk or other accessible media.

### Local Operations

To save the current module configuration to an E-MEM register stored on the 8921DAC module, select the **Learn** button. Recall a configuration stored in the Local Operations E-MEM register by selecting the **Recall** button.

Figure 16. 8921DAC E-MEM Web Page (Standard View)



Model: [8921DAC](#) Description: [4 Chan Aud DAC/Dly](#)  
 Frame Location: [Modular Lab](#) , Slot: [1](#)  
 Last Recalled E-MEM: -

		Local Operations	File Operations	
Current			Save to...	Load from...
E-MEM :	Recall	Learn	Save to...	Load from...
Recall Defaults				

### File Operations

Module configurations can also be saved and recalled to/from a file for storage in another location outside of the frame.

To save the current configuration to a file:

1. Select the **Save to...** button.
2. This will bring up a File Download screen.
3. Select the **Save** button.

4. In the resulting Save As dialog box (Figure 17), the default file name can be changed to an identifying name for the file, such as Audio\_Studio\_1. Browse to the folder where you want to save the configuration and select **Save**. The file saves as a .mcm file type.

Figure 17. E-MEM Save to Operation

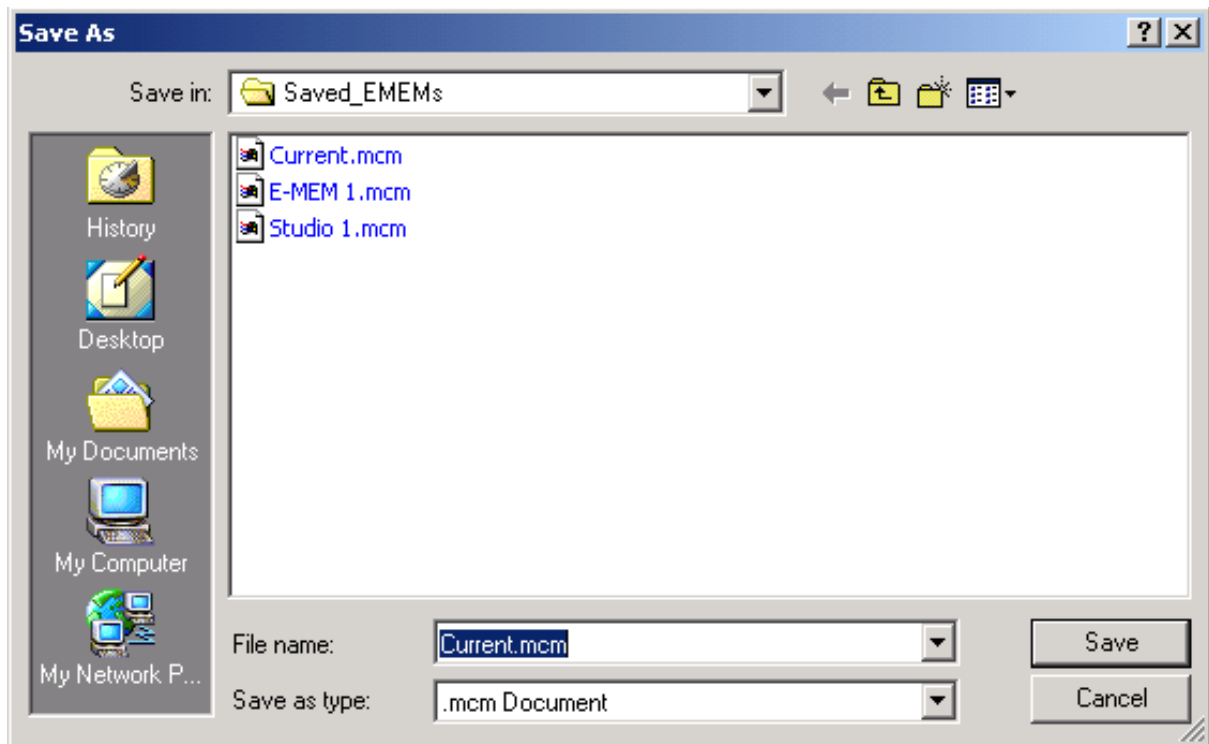

To load a saved file from a location outside of the frame

1. Select the **Load from ...** button under File Operations.  
This will bring up the Load Current Config page (Figure 18).
2. Browse to the location of the file you wish to load and select the file.  
Select the **Open** button to load the file or enter the filename and path in the Enter filename box.
3. Once the correct path and filename is loaded, select the **Load** button on the Load E-MEM page.
4. This will place the recalled configuration from the file into a module register.
5. Select **Recall** to apply the new settings.

Figure 18. Load Current Config Page

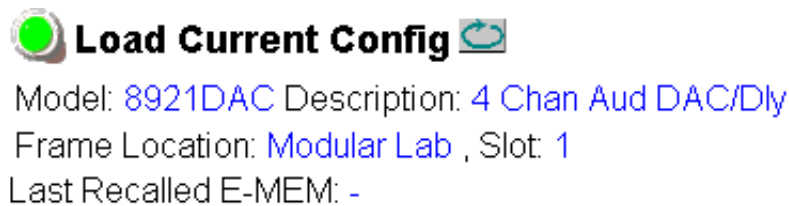

### Recall Defaults

Default settings for the module can be recalled by selecting the **Recall Defaults** button. The defaults will revert to the settings given in the Default column in Table 3 on page 17.

## Slot Config Page

Use  
this  
link

- [10 8921DAC](#)
- [Status](#)
- [I/O Config](#)
- [Functional View](#)
- [Audio Channel Pairing](#)
- [Audio Delay](#)
- [Audio Proc](#)
- [Analog Audio Outputs](#)
- [E-MEM®](#)
- [Slot Config](#)
- [Software Update](#)

Use the Slot Config page ([Figure 19 on page 38](#)) to perform the following functions on the 8921DAC module:

- **Locate Module** – selecting Flash in the **Locate Module** pulldown flashes the yellow COMM and CONF LEDs on the front of the module so it can be located in the frame.
- **Slot Identification** – You may identify the module by typing a specific name in the **Name** field. The assigned name is stored on the 8900NET module and travels with the 8900NET module if it is moved to another frame. Select **Default** to enter the factory default module name.

An asset identifier may be entered into the **Asset Tag** field for inventory purposes (functionality requires 8900NET software 3.2.1 or later). The asset tag will appear on the Status web page and can be used in the Inventory function with the NetConfig Network application.

- **Slot Memory** – the slot configuration for each media module is automatically saved periodically (once an hour) to the 8900NET module in that frame. You may also select the **Learn Module Config** button at any time to save the current configuration for this slot. The configuration is saved on the 8900NET module. If the 8900NET module is removed or powered down, the stored configurations are not saved.

When the **Restore upon Install** box has been checked, the current configuration saved to this slot is saved as slot memory. When the current module is removed and another module of the same type is installed, the configuration saved to the 8900NET module will be downloaded to the new module. The box must be checked before the current module with the saved configuration is removed.

- **Frame Health Reporting** – this function is not used on the current version of 8900NET software which controls this page.
- **Hardware Switch Controls** – a read-only status report of 8900NET module switch settings for Module Status Reporting and Asynchronous Status Reporting. These functions must be enabled for the following Slot SNMP Trap Reports to function.
- **Slot SNMP Trap Reports** – displayed only when the SNMP Agent software has been installed on the 8900NET module. Slot SNMP traps can be enabled only when the hardware switches for Module Fault reporting and Asynchronous Status reporting are in enabled on the 8900NET module (dipswitch S1 segment 5 and dipswitch S2 segment 1).

The enabled SNMP traps will be reported to any SNMP manager that is identified as an SNMP Report Destination in 8900NET configuration. Trap severity is read-only hard-coded information that is interpreted and responded to by the SNMP Manager software configuration.

SNMP reporting can be also be disabled for individual signal inputs on the I/O Config web page.

Figure 19. 8921DAC Slot Config Page

 **Slot Config** 

Model: [8921DAC](#) Description: [4 Chan Aud DAC/Dly](#)  
 Frame Location: [Modular Lab](#) , Slot: [1](#)

**Locate Module**

▾

**Slot Identification**

Name:

Asset Tag:

**Slot Memory**

Restore upon Install

**Frame Health Reporting**

	Slot Fault	Signal Loss	Reference Loss
Enabled	<input checked="" type="checkbox"/>	<input checked="" type="checkbox"/>	<input checked="" type="checkbox"/>

**Hardware Switch Controls**

Module Status Reporting: [Enabled](#) Asynchronous Status Reporting: [Enabled](#)

**Slot SNMP Trap Reports**

	Slot Fault	Module Removed	Signal Loss	Reference Loss
Enabled	<input checked="" type="checkbox"/>	<input checked="" type="checkbox"/>	<input checked="" type="checkbox"/>	<input checked="" type="checkbox"/>
Trap Severity	<a href="#">Alarm</a>	<a href="#">Warning</a>	<a href="#">Warning</a>	<a href="#">Warning</a>

## Software Update Page

- 10 8921DAC
- [Status](#)
  - [I/O Config](#)
  - [Functional View](#)
  - [Audio Channel Pairing](#)
  - [Audio Delay](#)
  - [Audio Proc](#)
  - [Analog Audio Outputs](#)
  - [E-MEM@](#)
  - [Slot Config](#)
  - [Software Update](#)
- Use this link \

The Software update page (Figure 20) allows updating of software from remote locations such as a CD-ROM or the Grass Valley web site. For instructions on updating to the latest software, refer first to the 8921DAC Release Notes that accompany the software update for complete details.

Updating with this method requires the use of an ftp server application available from the Grass Valley web site. Refer to the 8900NET Network Interface Instruction Manual for instructions for installing and using the ftp server application.

Software updates may also be performed using the NetConfig application available from Grass Valley. Refer to the NetConfig Instruction Manual for more information.

Figure 20. 8921DAC Software Update Page

### **Software Update**

Model: 8921DAC Description: 4 Chan Aud DAC/Dly

Frame Location: Modular Lab , Slot: 1

Software Version: 1.0.0      Firmware Version: 0.0.1

[Enter Username, Password and File to Initiate Update](#)

	selection	current setting
FTP Server Address:	<input type="text" value="10.16.4.103"/>	10.16.4.103
File Path:	<input type="text" value="Enter Filename Here"/>	<a href="#">Enter Filename Here</a>
FTP UserName:	<input type="text"/>	Moduser
FTP Password:	<input type="password"/>	
	<input type="button" value="Apply"/>	

## Newton Control Panel Configuration

A Newton Control Panel can be interfaced to the Gecko 8900 Series frame over the local network to control a number of module configuration and control parameters. The available control panel controls for the 8921DAC are listed in [Table 3 on page 17](#).

An example of the Newton Configurator is shown in [Figure 21](#).

Figure 21. Newton Configurator Example

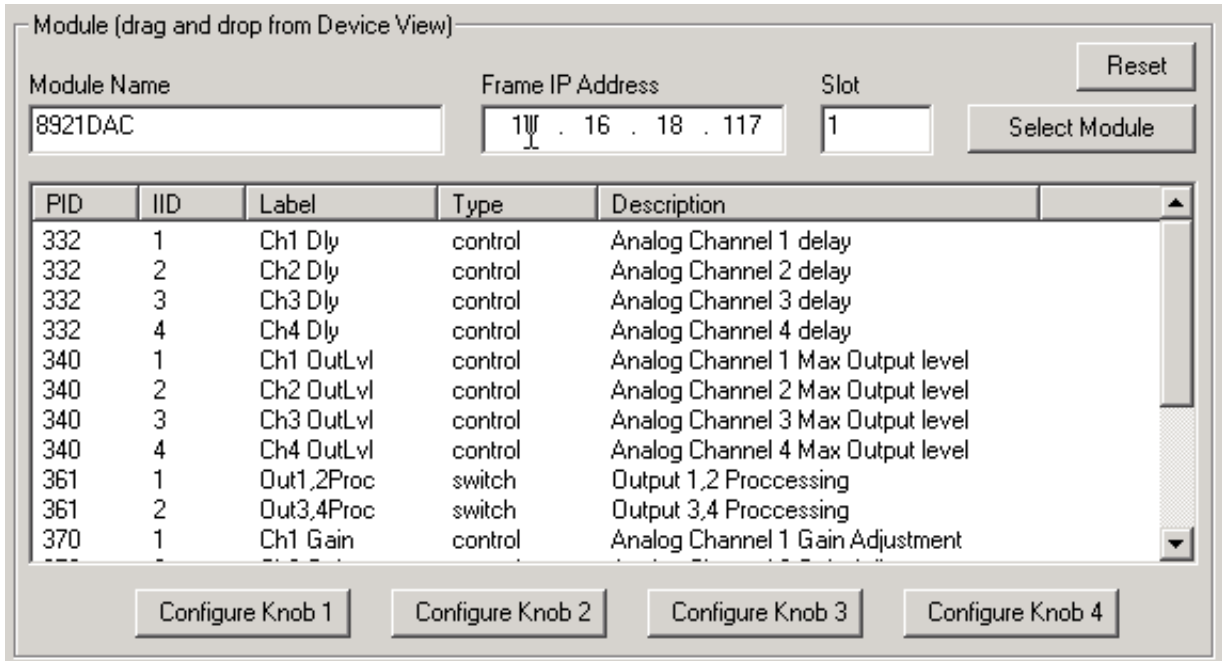

Refer to the documentation that accompanies the Newton Control Panel for installation, configuration, and operation information.



# Specifications

Table 6. 8921DAC Specifications

Parameter	Value
<b>Digital Inputs</b>	
<b>Balanced inputs</b>	
Audio input signal type	AES3-1997
Number of inputs	2 balanced
Input impedance	110 $\Omega$ $\pm$ 10%
Connector type	3-pin terminal blocks J9 (AES 1 A/B In) and J10 (AES 2 C/D In)
Common mode range	$\pm$ 10V
Differential voltage range	200 mV to 10 V p-p
Sampling rates supported	32 kHz to 96 kHz
Input return loss	> 20 dB (100 kHz to 10 MHz)
<b>Unbalanced inputs</b>	
Audio input signal type	AES3id-1995
Number of inputs	2 unbalanced
Input impedance	75 $\Omega$ $\pm$ 10%
Connector type	2 BNCs J11 (AES 1 A/B In) and J12 (AES 2 C/D In)
Differential voltage range	200 mV to 1.2 V p-p
Sampling rates supported	32 kHz to 96 kHz
Input return loss	> 20 dB (100 kHz to 10 MHz)
<b>Digital Audio Outputs</b>	
Digital audio output signal	AES3-1992
Number of outputs	4
Output impedance	110 $\Omega$ $\pm$ 20%
Connector type	3-pin terminal block (AES Out 1 – J5, AES Out 2 – J7, AES Out 3 – J6, AES Out 4 – J8)
Output rise/fall time	5 ns to 30 ns with 110 $\Omega$ load
Differential voltage range	3.4 V p-p $\pm$ 0.2 V @ 110 $\Omega$
Sampling rates supported	32 kHz to 96 kHz (AES input sample rate)
Output return loss	> 15 dB (100 kHz to 6 MHz)
<b>Analog Audio Output Signal</b>	
Number of outputs	4 channels, 1 output each channel
Output impedance	$\leq$ 5 $\Omega$ single-ended and $\leq$ 10 $\Omega$ differential
Output level (0 dBFS input)	0 dBu to + 24 dBu maximum
Output impedance	$\leq$ 10 $\Omega$ single-ended and $\leq$ 20 $\Omega$ differential
Connector type	3-pin terminal block (Audio Out 1 – J1, Audio Out 2 – J2, Audio Out 3 – J3, Audio Out 4 – J4)
Maximum differential DC on output	< $\pm$ 50 mV
Output to output isolation	> 95 dB
Maximum drive capability THD+N < 0.012%	+ 24 dBu into 10 k $\Omega$ load + 18 dBu into 600 $\Omega$ load

Table 6. 8921DAC Specifications

Parameter	Value
<b>Performance (+ 24 dBu into 10 k <math>\Omega</math> load unless otherwise stated)</b>	
Signal/noise ratio	> 104 dB unwatched 22 kHz filter > 107 dB "A" weighted
THD + noise (swept, 20 to 20 kHz)	< 0.012% 22 kHz filter, + 24 dBu (- 78 dB), typical (1 kHz): < - 87 dB
Interchange crosstalk	< - 100 dB, 20 Hz to 20 kHz
Intermediation distortion	< 0.015% CCIF two-tone test (- 76 dB) 19 kHz and 20 kHz tones
Frequency response	$\pm$ 0.1 dB, 20 Hz to 20 kHz, relative to 1 kHz @ 48 kHz to 96 kHz
De-emphasis (32 kHz to 48 kHz)	50/15 $\mu$ s pre-emphasis Automatic, Professional Mode only, no de-emphasis at output
Minimum delay from input to output	3.8 msec @ 48 kHz in/out sample rate
Delay at maximum delay setting	5.4 seconds @ 48kHz in/out sample rate
Static withstand	5 Kiev (330 $\Omega$ , 150 if) for any input or output
Factory calibration	0 dBFS = + 24 dBu $\pm$ 0.1 into 10 k $\Omega$ Mode and control switches set to 0
<b>Environmental</b>	
Frame temperature range	See frame specification
Operating humidity range	0 to 90% non-condensing
Non-operating temperature	- 10 to 70 degrees C
<b>Mechanical</b>	
Frame type	Gecko 8900 Audio
<b>Power</b>	
Power consumption	< 7 W, 500 mA @ + 12 V, 150 mA @ - 12V

# Service

The 8921DAC modules make extensive use of surface-mount technology and programmed parts to achieve compact size and adherence to demanding technical specifications. Circuit modules should not be serviced in the field unless directed otherwise by Customer Service.

If your module is not operating correctly, proceed as follows:

- Check frame and module power and signal present LEDs.
- Verify power at the voltage testpoints (see [Figure 22](#)).

**Note** The 8921DAC module does not use fuses. It has an electronic circuit breaker that protects against short circuits or excessive supply current with automatic restart after 150 ms. Current limits are set to 4 A on the + 12 V input and 2 A on the – 12 V input supply.

- Check for presence and quality of input signals.
- Verify that source equipment is operating correctly.
- Check cable connections.
- Check output connections for correct I/O mapping (correct input connector is used for the corresponding channel output).

Refer to [Figure 5](#) for the location of PWR LED and [Table 2 on page 13](#) for proper LED indications.

If the module is still not operating correctly, replace it with a known good spare and return the faulty module to a designated Grass Valley repair depot. Call your Grass Valley representative for depot location.

Refer to the [Contacting Grass Valley](#) at the front of this document for the Grass Valley Customer Service Information number.

Figure 22. 8921DAC Voltage Testpoint Locations



## Status Monitoring

This section provides a summary of status monitoring and reporting for a Gecko 8900 Series system. It also summarizes what status items are reported and how to enable/disable reporting of each item. There are a number of ways to monitor status of modules, power supplies, fans and other status items depending on the method of monitoring being used.

8900 Frame status will report the following items:

- Power supply health,
- Status of fans in the frame front cover,
- Temperature,
- Module health, and
- Frame bus status.

Module health status will report the following items:

- Internal module state (and state of submodule or options enabled) including configuration errors (warning), internal faults, and normal operation (Pass).
- Signal input states including valid/present (pass), not present or invalid (warning), not monitored, and not available (no signal inputs).
- Reference input states including locked/valid (pass), not locked/invalid (warning), and not monitored.
- Signal output states with reporting functionality (reference output).

## LEDs

LEDs on modules in the frame and on the front of the 8900TF/TFN frames indicate status of the frame and the installed power supplies, fans in the front covers, and modules. (The 8900TX-V/A frames have no LED indicators on the front cover.)

When a red FAULT LED is lit on a frame front cover, the fault will also be reported on the 8900NET or Frame Monitor module. The LEDs on the front of these modules can then be read to determine the following fault conditions:

- Power Supply 1 and 2 health,
- Fan rotation status,
- Frame over-temperature condition,
- Frame Bus fault (8900NET only), and
- Module health bus.

In general, LED colors used on the frame and modules indicate:

- Green = normal operation, (Pass) or signal present, module locked.
- Red – On continuously = fault condition, flashing = configuration error.
- Yellow – On continuously = active condition (configuration mode or communication), flashing in sequence = module locator function.

Status LEDs for this module are described in [Operation Indicator LEDs on page 13](#). LEDs for the 8900NET module are described in the *8900NET Network Interface Instruction Manual*.

## Frame Alarm

A Frame Alarm connection is available on pins 8 and 9 of the RS-232 connector on the rear of the 8900 frame (Frame Monitor or 8900NET Network Interface module required). This will report any of the status items enabled with the 8900NET or Frame Monitor module configuration DIP switch. Connection and use of the Frame Alarm is covered in detail in the *8900NET Network Interface Instruction Manual*.

## Web Browser Interface

When the 8900NET module is installed in the frame, a web browser GUI can indicate frame and module status on the following web pages:

- Frame Status page – reports overall frame and module status in graphical and text formats.
- Module Status page – shows specific input and reference signal status to the module along with enabled options and module versions.
- A Status LED icon on each web page to report communication status for the frame slot and acts as a link to the Status page where warnings and faults are displayed (8900NET version 3.0 or later).

In general, graphics and text colors used indicate the following:

- Green = Pass – signal or reference present, no problems detected.
- Red = Fault – fault condition.
- Yellow = Warning – signal is absent, has errors, or is mis-configured.
- Gray = Not monitored (older 8900 module).
- White = Not used.

Status reporting for the frame is enabled or disabled with the configuration DIP switches on the 8900NET module. Most module status reporting items can be enabled or disabled on individual configuration web pages.

## **SNMP Reporting**

The Gecko 8900 Series system uses the Simple Network Monitoring Protocol (SNMP) internet standard for reporting status information to remote monitoring stations. When SNMP Agent software is installed on the 8900NET module, enabled status reports are sent to an SNMP Manager such as the Grass Valley's NetCentral application.

There are both hardware and software report enable switches for each report. Both must be enabled for the report to be sent. Software report switches are set on the 8900NET Configuration page for the Frame, the 8900NET module, and each module slot. Refer to the *8900NET Network Interface Instruction Manual* for installation instructions.

# Index

## Numerics

- 2ND LED [20](#)
- 8900 frame
  - frame alarm [45](#)
  - module capacity [9](#)
  - status reporting [44](#)
- 8900NET module
  - installation [9](#)
- 8921DAC features [7](#)

## A

- analog audio outputs
  - levels, overview [16](#)
  - levels, remote control [33](#)
  - levels, summary table [18](#)
- Analog Audio Outputs web page [33](#)
- Asset Tag
  - assignment [37](#)
- audio channel pairing
  - local control [21](#)
  - remote control [30](#)
  - summary table [17](#)
- Audio Channel Pairing web page [30](#)
- audio delay
  - local controls [21](#)
  - overview [14](#)
  - remote control [31](#)
  - summary table [17](#)
- Audio Delay web page [31](#)
- audio inputs
  - cabling [10](#)
  - unbalanced, cabling [10](#)
- audio outputs
  - AES outputs [11](#)
  - analog outputs [11](#)
- Audio Proc web page [32](#)
- audio processing
  - modes
    - rotary switch setting table [22](#)
  - overview [14](#)

- remote controls [32](#)
- summary table [18](#)

## B

- backplane [10](#)
- BANK 2 LED [13](#)

## C

- CH SEL 1-4 LEDs [13](#)
- CH1-4 AUDIO LEV LEDs [13](#)
- COMM LED [13](#)
- CONF LED [13, 20](#)
- configuration
  - Local, onboard [19](#)
  - overview [14](#)
  - Remote, GUI [23](#)
  - summary table [17](#)
- connectors [10](#)
- control panel [40](#)
  - mneumonics [17](#)
- controller module [9](#)

## D

- documentation online [2](#)

## E

- E-MEM
  - description [34](#)
  - load from file [36](#)
- E-MEM web page [34](#)
- enable SNMP [46](#)
- environmental [42](#)
- ERR AES1 LED [13](#)
- ERR AES2 LED [13](#)

## F

- factory defaults
  - local control [21](#)
  - remote control [36](#)
  - summary table [17](#)
- FAQ database [2](#)
- FAULT LED
  - states [13](#)
  - troubleshooting [44](#)
- Frame Controller module [9](#)
- Frame Status page [45](#)
- frequently asked questions [2](#)
- Function rotary switch
  - accessing banks [20](#)
- Functional View web page [28](#)
- fuses [43](#)

## G

- gain
  - local controls [21](#)
  - overview [16](#)
  - remote control [32](#)
  - summary table [17](#)
- Gecko frame [9, 42](#)
- graphical user interface (GUI) [25](#)
- Grass Valley web site [2](#)

## I

- I/O Config web page [27](#)
- installation [8](#)

## L

- LEDs
  - front edge [13](#)
  - Names and Meanings table [13](#)
- locate module [37](#)

## M

- module
  - controller [9](#)
  - installation [9](#)
  - power supply [9](#)

- slots [10](#)
- module health status [44](#)
- Module Status page [45](#)

## N

- NetConfig
  - software updating [39](#)
- Newton Control Panel [40](#)

## O

- online documentation [2](#)
- output processing modes
  - Channel 1 and 2 [15](#)
  - Channel 3 and 4 [16](#)

## P

- power [42](#)
- power supply [9](#)
- PWR LED [13](#)

## R

- rear connectors [10](#)
- Refresh button [23](#)
- repair depot [43](#)
- report enable switches [46](#)

## S

- Slot Config web page [37](#)
- slot memory [37](#)
- SNMP reporting
  - enabling [37](#)
  - overview [46](#)
- software download from web [2](#)
- Software Update web page [39](#)
- specifications [41](#)
- status monitoring [44](#)
- Status web page [26](#)
- switches
  - onboard control [19](#)



## **T**

testpoints [43](#)  
troubleshooting [43](#)

## **V**

voltage tespoints [43](#)

## **W**

web site documentation [2](#)  
web site FAQ database [2](#)  
web site Grass Valley [2](#)  
web site software download [2](#)

