



Grass Valley

XIP-3911 & XIP-3901

Agile SDI/IP Processing Platform

User Manual

13-03065-010-AO-M00

2024-03-14

www.grassvalley.com

Notices

FCC Compliance

In order to comply with FCC/CFR47: Part 15 regulations, it is necessary to use high-quality, triple-screened Media or Monitor cable assemblies with integrated ferrite suppression at both ends.

Patent Information

This product may be protected by one or more patents.

For further information, please visit: www.grassvalley.com/patents/

Copyright and Trademark Notice

Grass Valley®, GV® and the Grass Valley logo and/or any of the Grass Valley products listed in this document are trademarks or registered trademarks of GVBB Holdings SARL, Grass Valley USA, LLC, or one of its affiliates or subsidiaries. All other intellectual property rights are owned by GVBB Holdings SARL, Grass Valley USA, LLC, or one of its affiliates or subsidiaries. All third party intellectual property rights (including logos or icons) remain the property of their respective owners.

Copyright © 2018 - 2024 GVBB Holdings SARL and Grass Valley USA, LLC. All rights reserved.

Specifications are subject to change without notice.

Terms and Conditions

Please read the following terms and conditions carefully. By using XIP-3911 & XIP-3901 documentation, you agree to the following terms and conditions.

Grass Valley hereby grants permission and license to owners of XIP-3911 & XIP-3901 to use their product manuals for their own internal business use. Manuals for Grass Valley products may not be reproduced or transmitted in any form or by any means, electronic or mechanical, including photocopying and recording, for any purpose unless specifically authorized in writing by Grass Valley.

A Grass Valley manual may have been revised to reflect changes made to the product during its manufacturing life. Thus, different versions of a manual may exist for any given product. Care should be taken to ensure that one obtains the proper manual version for a specific product serial number.

Information in this document is subject to change without notice and does not represent a commitment on the part of Grass Valley.

Warranty information is available from the Legal Terms and Conditions section of Grass Valley's website (www.grassvalley.com).

Title XIP-3911 & XIP-3901 User Manual

Part Number 13-03065-010-AO-M00

Revision 2024-03-14, 14:41

Document History

Document Number	Publication Date	Notes
13-03065-010-AA-M00	2018-06-14	Initial release
13-03065-010-AB-M00	2018-09-25	External reference support for XIP-3901-UC 1.1 XIP-3901-DC 1.0 release Agile processing platform manager for XIP-3901-UC 1.1 and XIP-3901-DC 1.0
13-03065-010-AC-M00	2018-11-23	XIP-3901-FS 1.0 release
13-03065-010-AD-M00	2019-02-15	Improved HDR settings and options New rear panel: XIP-3901-3+DRP-HD
13-03065-010-AE-M00	2020-01-24	Improved HDR settings and options: <ul style="list-style-type: none"> • Support of HDR BBC LUTs • Support of HDR Custom LUTs • Possibility to force a new Video Payload ID (Transfer Characteristic, Colorimetry, and Bit depth) • HLG and PQ Test Pattern Network: <ul style="list-style-type: none"> • New Bridged network interface through the frame • DHCP • LLDP • Network settings and statuses on local menu XIP-3901-DC: <ul style="list-style-type: none"> • DC1 SDI output duplicated on OUT2, 3, 4 • DC2 SDI output duplicated on OUT6, 7, 8 • On Quad Link 3G SDI inputs, possibility to select audio and metadata source XIP-3901-FS: <ul style="list-style-type: none"> • Transport of audio on link 2, 3, 4 in Quad Link 3G – 2SI/Square Operation mode.
13-03065-010-AF-M00	2020-02-06	Documented a card upgrade procedure to add and select a card application.
13-03065-010-AG-M00	2020-04-09	Documented the XIP-3901-UDC-IP V1.0 application.
13-03065-010-AH-M00	2020-06-18	Documented the XIP-3901-GB-IP application.

Document Number	Publication Date	Notes
13-03065-010-AI-M00	2020-07-31	<p>Documented the XIP-3901-UDC-IP V1.1 application update. Added Support for:</p> <ul style="list-style-type: none"> • Processing of common film rates 23.98p and 29.97p Hz to and from 59.94 Hz material. • Colorimetry and Transfer Characteristics System (TCS) information displayed/set at IP Receivers end • Time-code selection processing and re-generation either directly from the PTP source or a 2110-40 stream. • Video processing toolset: <ul style="list-style-type: none"> • Proc-Amp (Luma/Chroma gain, Black, Hue) • Color Corrector (RGB Gain, Offset & Gamma) • Gamut Legalization • Detail Horizontal and Vertical enhancer support on down-converted paths. <p>Documented the XIP-3901-UC/DC/FS V2.1.0: Support for BBCLUTs v1.4.</p>
13-03065-010-AJ-M00	2020-09-10	<p>Documented the XIP-3901-UDC-IP V1.2 application update. Added Support for:</p> <ul style="list-style-type: none"> • New HD Monitoring output for UDC1 in the Senders panel. • New PTP Locked indicator in the PTP Panel.
13-03065-010-AK-M00	2020-12-10	Documented the XIP-3901-UDC-IF V3.0.0 application update.
13-03065-010-AL-M00	2021-08-04	Documented the XIP-3901-JPEG-XS V1.0.0 application.
13-03065-010-AM-M00	2021-09-08	Documented the XIP-3901-UDC-IF V4.0 application update.
13-03065-010-AN-M00	2023-02-07	Documented the XIP-3901-ASI V1.0.0 application.
13-03065-010-AO-M00	2024-03-14	Documented the new XIP-3911 modular platform.

Electrostatic Discharge (ESD) Protection



Electrostatic discharge occurs when electronic components are improperly handled and can result in intermittent failure or complete damage adversely affecting an electrical circuit. When you remove and replace any card from a frame always follow ESD-prevention procedures:

- Ensure that the frame is electrically connected to earth ground through the power cord or any other means if available.
- Wear an ESD wrist strap ensuring that it makes good skin contact. Connect the grounding clip to an *unpainted surface* of the chassis frame to safely ground unwanted ESD voltages. If no wrist strap is available, ground yourself by touching the *unpainted* metal part of the chassis.
- For safety, periodically check the resistance value of the antistatic strap, which should be between 1 and 10 megohms.
- When temporarily storing a card make sure it is placed in an ESD bag.

- Cards in an earth grounded metal frame or casing do not require any special ESD protection.

Protection contre les décharges électrostatiques (DES)



Une décharge électrostatique peut se produire lorsque des composants électroniques ne sont pas manipulés de manière adéquate, ce qui peut entraîner des défaillances intermittentes ou endommager irrémédiablement un circuit électrique. Au moment de remplacer une carte dans un châssis, prenez toujours les mesures de protection antistatique appropriées :

- Assurez-vous que le châssis est relié électriquement à la terre par le cordon d'alimentation ou tout autre moyen disponible.
- Portez un bracelet antistatique et assurez-vous qu'il est bien en contact avec la peau. Connectez la pince de masse à une *surface non peinte* du châssis pour détourner à la terre toute tension électrostatique indésirable. En l'absence de bracelet antistatique, déchargez l'électricité statique de votre corps en touchant une surface métallique *non peinte* du châssis.
- Pour plus de sécurité, vérifiez périodiquement la valeur de résistance du bracelet antistatique. Elle doit se situer entre 1 et 10 mégohms.
- Si vous devez mettre une carte de côté, assurez-vous de la ranger dans un sac protecteur antistatique.
- Les cartes qui sont reliées à un châssis ou boîtier métallique mis à la terre ne nécessitent pas de protection antistatique spéciale.

Environmental Information

European (CE) WEEE directive.



This symbol on the product(s) means that at the end of life disposal it should not be mixed with general waste.

Visit www.grassvalley.com for recycling information.

Grass Valley believes this environmental information to be correct but cannot guarantee its completeness or accuracy since it is based on data received from sources outside our company. All specifications are subject to change without notice.

If you have questions about Grass Valley environmental and social involvement (WEEE, RoHS, REACH, etc.), please contact us at environment@grassvalley.com.

Laser Safety - Fiber Output SFP and QSFP Modules Warning

LASER SAFETY



The average optical output power does not exceed 0 dBm (1mW) under normal operating conditions. Unused optical outputs should be covered to prevent direct exposure to the laser beam.

Even though the power of these lasers is low, the beam should be treated with caution and common sense because it is intense and concentrated. Laser radiation can cause irreversible and permanent damage of eyesight. Please read the following guidelines carefully:

- Make sure that a fiber is connected to the board's fiber outputs before power is applied. If a fiber cable (e.g. patchcord) is already connected to an output, make sure that the cable's other end is connected, too, before powering up the board.
- **Do not** look in the end of a fiber to see if light is coming out. The laser wavelengths being used are totally invisible to the human eye and can cause permanent damage. Always use optical instrumentation, such as an optical power meter, to verify light output.

Safety and EMC Standards

This equipment complies with the following standards:

Safety Standards



Information Technology Equipment - Safety Part 1

EN60950-1: 2006

Safety of Information Technology Equipment Including Electrical Business Equipment.

UL1419 (4th Edition)

Standard for Safety – Professional Video and Audio equipment (UL file number E193966)

EMC Standards

This unit conforms to the following standards:

EN55032:2015 (Class A)

Electromagnetic Compatibility of multimedia equipment - Emission requirements

EN61000-3-2:2014 (Class A)

Electromagnetic Compatibility - Limits for harmonic current emissions

EN61000-3-3:2013

Electromagnetic Compatibility - Limits of voltage changes, voltage fluctuations and flicker

EN55103-2:2009 (Environment E2)

Electromagnetic Compatibility, Product family standard for audio, video, audio-visual and entertainment lighting control apparatus for professional use. Part 2. Immunity

WARNING

This equipment is compliant with Class A of CISPR 32. In a residential environment this equipment may cause radio interference.

FCC / CFR 47:Part 15 (Class A)

Federal Communications Commission Rules Part 15, Subpart B

Caution to the user that changes or modifications not expressly approved by the party responsible for compliance could void the user's authority to operate the equipment.

Note: This equipment has been tested and found to comply with the limits for a Class A digital device, pursuant to part 15 of the FCC Rules. These limits are designed to provide reasonable protection against harmful interference when the equipment is operated in a commercial environment. This equipment generates, uses, and can radiate radio frequency energy and, if not installed and used in accordance with the instruction manual, may cause harmful interference to radio communications. Operation of this equipment in a residential area is likely to cause harmful interference in which case the user will be required to correct the interference at his own expense.

EMC Performance of Cables and Connectors

Grass Valley products are designed to meet or exceed the requirements of the appropriate European EMC standards. In order to achieve this performance in real installations it is essential to use cables and connectors with good EMC characteristics.

All signal connections (including remote control connections) shall be made with screened cables terminated in connectors having a metal shell. The cable screen shall have a large-area contact with the metal shell.

SIGNAL/DATA PORTS

For unconnected signal/data ports on the unit, fit shielding covers. For example, fit EMI blanking covers to SFP+ type ports; and fit 75 Ω RF terminators to BNC type ports.

COAXIAL CABLES

Coaxial cables connections (particularly serial digital video connections) shall be made with high-quality double-screened coaxial cables such as Belden 8281 or BBC type PSF1/2M, Belden 1694A (for 3Gbps), and Belden 4794A (for 12Gbps).

Notices

toc

Table of Contents

1 Introduction to the XIP-3911 and XIP-3901 Agile SDI/IP Processing Platform	19
2 Applications	21
XIP-3901 -UC / -DC / -FS SDI Applications	21
XIP-3901 -UC / -DC / -FS Key Features	22
XIP-3901 -UC / -DC / -FS Supported Video Formats	23
Functional Block Diagrams	23
XIP-3901-UDC-IP Applications	24
XIP-3901-UDC-IP Key Features	25
XIP-3901-UDC-IP Supported Video Formats	26
Optional XIP-3901-UDC-IP Application Audio processing, Down/Up Mix, Shuffling	27
Functional Block Diagram	28
XIP-3901-UDC-IF v4.0 Application	28
XIP-3901-UDC-IF Key Features	29
XIP-3901-UDC-IF Supported Video Formats	31
Optional XIP-3901-UDC-IF v4.0 Application Audio processing, Down/Up Mix, Shuffling	31
Functional Block Diagram	32
XIP-3901-GB-IP Application	32
XIP-3901-GB-IP Key Features	33
XIP-3901-GB-IP Supported Video Formats	34
Functional Block Diagram	35
Optional HDR Processing	35
XIP-3901-JPEG-XS Application	36
XIP-3901-JPEG-XS Key Features	37
XIP-3901-JPEG-XS Functional Block Diagram	37
XIP-3901-ASI Application	37
XIP-3901-ASI Key Features	39
XIP-3901-ASI Functional Block Diagram	40
3 XIP-3911 & XIP-3901 Installation and Operation	41
Front Card-edge Interface	41
Card-edge Status LED	41
Installation	47
Fiber Optic Handling	47
Getting Organized / Unpacking	47
Required Tools	47
Required Material	47
Installation of the Rear Connector Panel and Card	48
Installation of the Optical Interface (option)	49
Rear Panel and Connectors	50

Images of Rear Panel Connectors	50
Summary of Rear Panel Connections	51
Details of Rear Panel Connections.....	52
REF IN – External reference	52
12G/3G/HD IN – Serial digital 3G/HD Inputs	52
12G/3G/HD OUT– Serial digital 12G/3G/HD outputs.....	54
ETH1, ETH2 – 25 GigE on fiber (SFP+)	56
GigE ETH3 – 1 GigE MANAGEMENT Port (RJ-45)	60
User Interface	60
Control options	60
4 Connections and Cabling.....	63
Cabling Diagrams XIP-3911 or XIP-3901	63
Cabling to Support SMPTE ST 2022-7.....	64
5 Local Control Using the Densité Frame Control Panel	67
Setting the Card’s IP Addresses	68
6 Getting Started with iControl.....	71
Card Upgrade with iControl Solo	71
Starting iControl Solo.....	71
Downloading new XIP applications	71
Installing new applications on the XIP-3911 or XIP-3901	71
Opening the XIP-3911 or XIP-3901 Panel	74
iControl System User Interface	76
Section 1: Status Icons	77
Section 2: Panel Selection Buttons	81
Section 3: Configuration Panel	83
Section 4: Current Preset or User Custom.....	83
XIP-3901 Card Application Configuration.....	84
7 Configuring the XIP-3901-UC / -DC / -FS Applications with iControl ...	85
Video Input/Output Panel (XIP-3901-UC)	85
Input/Output Config Tab	85
Timing Tab.....	87
Deglitcher Tab	90
De-interlacer Tab.....	91
Video Input/Output Panel (XIP-3901-DC)	92
Input/Output Config Tab	92
Timing Tab.....	94
Deglitcher Tab	96
Video Input/Output Panel (XIP-3901-FS).....	98
Input/Output Config Tab	98
Timing Tab.....	100
12G/3G/HD and Quad Link 3G.....	102
3G Level A/B DL.....	103

Quad Link 3G – 2SI/Square	104
Quad Link 3G to 12G	106
12G to Quad Link 3G	106
Deglitcher Tab	108
Clean Switch Regions and Examples	109
HDR Panel.....	111
UC1&2 / DC1&2 / FS1&2 Tabs	111
Custom LUTs Tab.....	114
Reference Panel	116
Test Panel	117
Status	119
Network Panel.....	119
Options Panel	122

8 Configuring the XIP-3901-UDC-IP v1.2 Application with iControl 125

Network Panel.....	125
Interface Tab	125
SFP Tab	128
Statistics Tab	129
FEC Tab	130
PTP Panel	131
NMOS Panel.....	133
Receivers Panel.....	134
Config Tab	135
Timing Tab.....	137
Redundancy Tab	138
Senders Panel	140
UDC1 Tabs	140
UDC2 Tab	143
Advanced Tab.....	145
Video Panel	147
Timing Tab.....	147
De-interlacer Tab	150
Detail Enhancer Tab	151
Video Proc Tab	153
Color Corrector Tab	154
Legalizer Tab	155
HDR Panel.....	156
UDC1 / UDC2 Tab	156
Custom Luts Tab	160
Metadata Panel.....	161
Audio Panel	164
Inputs Tab	165
Mixer Tab	166
Upmix Tab	168
Downmix Tab	170
Outputs Tab.....	172
Test Panel	174
Status.....	176

Options Panel	176
9 Configuring the XIP 3901-UDC-IF v4.0 Application with iControl	179
Setting the Card's Operating Mode.....	180
Network Panel.....	182
PTP Panel	183
NMOS Panel.....	185
Reference Panel	186
Inputs/Outputs Panel.....	188
Config Tab	189
Timing Tab.....	193
Processing Delay.....	194
Bulk Video and Audio Delay.....	195
Deglitcher Tab	196
De-interlacer Tab.....	197
Enhancement Tab.....	198
Video Proc Tab	199
Color Corrector Tab	200
Legalizer Tab.....	200
Receivers Panel.....	201
Config Tab	201
Timing Tab.....	204
Redundancy Tab	206
Senders Panel	207
UDC _n Tabs	207
Advanced Tab.....	210
HDR Panel.....	212
UDC _n Tabs	212
Custom LUTs Tab.....	219
Metadata Panel.....	222
Audio Panel	225
Inputs Tab	225
Mixer Tab	227
Upmix Tab	229
Downmix Tab	231
Outputs Tab.....	234
Test Panel.....	237
10 Configuring the XIP-3901-GB-IP Application with iControl	239
Network Panel.....	239
PTP Panel	239
NMOS Panel.....	239
Receivers Panel.....	239
Config Tab	240
Timing Tab.....	243
Redundancy Tab	244
Senders Panel	244
GB1 / GB2 Tabs.....	245

Advanced Tab.....	247
Video Panel	247
Timing Tab.....	247
Metadata Panel.....	248
Test Panel.....	248

11 Common Configuration iControl Panels249

Factory/Presets Panel.....	249
User Presets.....	250
Load Factory button.....	251
Profiles	251
Copy profile from.....	252
Restore profile from disk.....	254
Copy profile to.....	254
Alarm Config Panel.....	255
Status/Name	256
Card LED, Overall Alarm and GSM Contribution.....	256
Card LED	256
Overall Alarm	256
GSM Contribution	256
Log Events	256
Copy to other cards	257
Get alarm keys	258
OK, Apply, Cancel.....	258
Info Panel	258
Application Panel.....	261

12 Getting Started with the Card's Web-based Configuration Interface .263

Connecting to the XIP-3911 & XIP-3901 Card's Configuration Interface	263
Downloading new XIP applications	263
Card Upgrade	263
Card Upgrade when the XIP-3901-JPEG-XS or XIP-3901-ASI Application is Currently Running on the Card	264
Card Upgrade when Another Application is Currently Running on the Card	266
Card's Web-based User Interface Overview	268
Section 1: Status Dashboard	269
Section 2: Bandwidth Usage	270
Section 3: Panel Selection Tree.....	271
Section 4: Configuration Panel.....	272
Using the Channel Selector	272
Card Status Messages.....	273
XIP-3911 or XIP-3901 Card Application Configuration.....	273

13 Configuring the XIP 3901-JPEG-XS v1.0 Application with its Web Interface275

Setting the Card's Operation Mode.....	275
--	-----

Processing Channel Selection and Video In and Video Out	276
XIP-3901-JPEG-XS Panel Selection Tree	277
Receivers Panel	278
Senders Panel	283
Video Panel	285
Audio Panel	288
Test Panel	289
Status	290
Advanced Panel	290
Interfaces Panel	291
FEC Panel	293
SFP Panel	294
Statistics Panel	295
PTP Panel	295
NMOS Panel	297
Info Panel	299
Operation Mode	300
Applications Panel	300
Activating an Application	300
Switching to a Different Application	301
Alarm Configuration Panel	302
Factory/Presets Panel	304
Upgrade Panel	305
Technical Support Panel	305

14 Configuring the XIP 3901-ASI v1.0

Application with its Web Interface	307
XIP-3901-ASI Panel Selection Tree	307
Receivers Panel	308
Senders Panel	310
TR 101 290 Probing Panel	311
Advanced Panel	313
Interfaces Panel	313
FEC Panel	316
SFP Panel	317
Statistics Panel	318
NMOS Panel	318
Info Panel	319
Friendly Names Panel	320
Alarm Configuration Panel	321
Factory/Presets Panel	323
Applications Panel	324
Activating an Application	324
Switching to a Different Application	325
Upgrade Panel	325
Technical Support Panel	325

15 Maintenance & Troubleshooting	327
Maintenance	327
Field Replaceable Units	327
Replacing Cards	327
Replacing a rear panel	328
Removing a card	328
Installing a Card	328
Cooling Fan Operational Assessment	328
Diagnostics	328
Critical Temperature Alarm Corrective Actions	329
Fan Noise	329
Fan Alarm and Fan Noise Corrective Actions	329
Replacing the XIP-3911 & XIP-3901's Fan	330
Fan Replacement Kit	330
Required Tools	330
Cooling Fan Replacement Procedure	330
Required Materials	330
Procedure	331
Troubleshooting	333
Keep Fiber Connections Clean	334
16 Technical Specifications	337
Appendix A Local Menu	339
Appendix B Installing the SFP Ethernet Module	341
Introduction	341
Installing an SFP module	341
Connecting the fiber optic cables	342
Removing the fiber optic cables	342
Removing the SFP module	343
Appendix C BBC HLG Look-Up Table	345
Introduction	345
LUT Details	345
Scene-Light versus Display-Light Conversions	346
Extending the SDR Color Gamut	348
Output Signal Clipping	348
Contact Us	354

Introduction to the XIP-3911 and XIP-3901 Agile SDI/IP Processing Platform

The Densité modular platform is Grass Valley's flagship platform for media related processing, and now composed of the DENSITÉ 3+ FR4 which is our highest density modular frame for advanced signal processing. The 4 RU Densité 3+ FR4 Frame is a modular frame and controller designed to deliver more power per slot and higher speed connectivity needed by the increased feature set of the latest Densité products.



Figure 1-1: Densité 3+ FR4 and Densité 3+ FR1 modular frames

The Densité 3+ FR4 frame offers true multi-format operation, with the ability to process simultaneously SDI and IP, 4K, 3G, UHD, HD, SD, and analog video, as well as AES and analog audio. The frame provides advanced monitoring and back-up capabilities along with a color LCD panel with integrated touchscreen for ease of status and control navigation on the front panel. The Densité 3+ FR4 frame can host any of the latest high-powered Densité modules, such as the XIP-3911 and XIP-3901.



Figure 1-2: Densité 3+ FR4 and XIP-3901

The XIP-3911 and XIP-3901 are agile processing platforms from Grass Valley that focus on high-quality live production for HD, 1080p, 4K UHD and HDR. This platform is a bridge for the hybrid world, consisting of today's proven SDI technology and the new IP SMPTE ST 2110 connectivity. The XIP-3911 and XIP-3901 agile processing platforms with a rear XIP-3911-3+DRP-H or XIP-3901-3+DRP comes with all the 12G/quad link3G/3G/HD-SDI connectivity to support two 4K UHD processing paths with dual 25 GbE SFP cages for SMPTE ST 2110 IP I/O applications. The XIP-3911 or XIP-3901 is installed in the established Densité modular frame, packing lots of audio/video processing power in a small form factor results in savings in terms of space, power and weight. With advanced processing capabilities and power requirements, the XIP-3911 and XIP-3901 are supported by both Densité 3+ FR1 and FR4 frames.

To meet our customers' needs now and in the future, both the XIP-3911 and XIP-3901 use a flexible "virtualized" hardware platform. Based on a powerful FPGA engine, the XIP-3911 and XIP-3901 can be reconfigured with software updates for different applications as requirements change.

XIP Application Agility Evolution

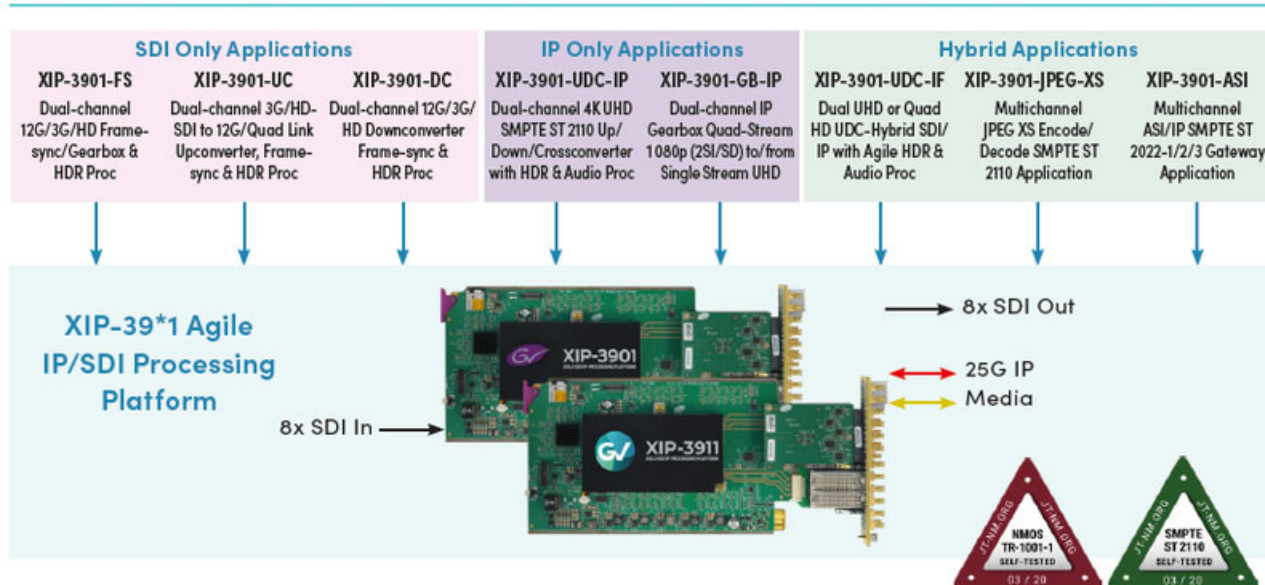

Figure 1-3: XIP-39*1 Application Agility Evolution

2 Applications

The XIP-3911 and XIP-3901 cards support a number of processing applications that can be individually activated on either card, thereby allowing the card to be redeployed for other uses. See [Application Panel](#), on page 261. This user manual describes the following applications only:

Application	See for an overview description
XIP-3901-UC, XIP-3901-DC, or XIP-3901-FS	XIP-3901 -UC / -DC / -FS SDI Applications , on page 21
XIP-3901-UDC-IP	XIP-3901-UDC-IP Applications , on page 24
XIP-3901-UDC-IF	XIP-3901-UDC-IF v4.0 Application , on page 28
XIP-3901-GB-IP	XIP-3901-GB-IP Application , on page 32
XIP-3901-JPEG-XS	XIP-3901-JPEG-XS Application , on page 36
XIP-3901-ASI	XIP-3901-ASI Application , on page 37

XIP-3901 -UC / -DC / -FS SDI Applications

The applications for the XIP-3911 and XIP-3901 agile IP/SDI processing platforms provide full functionality of up/down/frame sync-gearbox processing capability delivered through three applications that allow your live productions — either from trucks, venues or stadiums — to make the most of the new 4K UHD and HDR formats. This includes playout channels where output of a 4K UHD HDR channel needs to be downconverted for an HD SDR simulcast version.

The XIP-3911 and XIP3901 agile processing platforms with the rear panel XIP-3911-3+DRP-H or XIP-3901-3+DRP-H comes with all the 12G/Quad Link 3G/3G/HD HD-BNC SDI connectivity to support two 4K UHD processing paths with the XIP-3901-UC/DC/FS applications. The rear panel is also available for DIN SDI connectivity for backward compatibility, but Grass Valley is now promoting the HD-BNC as the miniature SDI connector going forward. The XIP-3911 and XIP-3901 are installed in a Densité modular frame. Due to advanced processing capabilities and power requirements, the XIP-3911 and XIP-3901 are supported only by the Densité 3+ FR1 and FR4 frames.

Densité 3+ XIP-3901-UC is an application that provides a dual-channel 12G/Quad Link 3G/3G/HD-SDI upconverter, which is designed to synchronize, upconvert and process HD and 3G 1080p signals for both 1080p and 4K UHD 2160p broadcast production. The XIP-3901-UC application features broadcast-quality scalers, motion-adaptive de-interlacers and color space conversions between ITU-R BT.709 and ITU-R BT.2020.

Densité 3+ XIP-3901-DC is an application that provides a dual-channel 12G/Quad Link 3G/3G/HD downconverter, which is designed to synchronize, downconvert and process 4K

UHD 2160p and 1080p for both 1080p and HD broadcast production. The XIP-3901-DC application features broadcast-quality down-scalers, interlacers and color space conversions between ITU-R BT.2020 and ITU-R BT.709.

Densité 3+ XIP-3901-FS is an application that provides a dual-channel 12G/Quad Link 3G/3G/HD frame synchronizer with gearbox functionality, which is designed to synchronize and convert color space between ITU-R BT.2020 and ITU-R BT.709 in 4K UHD, 1080p and HD broadcast productions.

All applications will delay 12G/3G/HD embedded audio and metadata to maintain synchronization with video. The optional HDR processor, XIP-3901-UDC-HDR, allows conversion between SDR and HDR formats, supporting HLG (ITU-R BT.2100), PQ (ITU-R BT.2100) and S-Log3/S-Gamut3 formats, with conversion between formats. In addition to the Grass Valley LUTs, you can select BBC LUTs v1.4 or you can choose your own Custom LUTs compliant to Adobe cube file v1.0 for fully flexible HDR processing.

Based on the proven Densité modular framework of over 100 cards, the flexible, space-efficient XIP-3911 and XIP-3901 agile processing platforms can accommodate a gradual adoption of different production elements into 1080p and 4K UHD broadcasting workflows — and it enables dual HDR/SDR production — all while protecting your investment in installed equipment. With flexibility to configure up to 12 XIP-3901 dual-channel processing applications per Densité 3+ FR4 frame, the Densité platform scales to a market-leading density of 24 4K UHD processors with HDR conversions in a 4 RU frame. This means space and cost-efficient scaling for today and tomorrow.

XIP-3901 -UC / -DC / -FS Key Features

- Independent dual processing channels
- 12G 2160p, 3G 1080p and HD 1080i/720p input/output (depending on application)
- 12G-SDI Mode 1 and Type 1
- Quad Link 3G in 2SI and Square Division
- 3G Level A & Level B Dual-Link
- High-quality scaler and advanced de-interlacer on XIP-3901-UC
- High-quality downscaler and interlacer on XIP-3901-DC
- 12G-SDI to/from Quad Link 3G in 2SI/Square Division on XIP-3901-FS
- Integrated frame synchronizer (freeze to last valid frame/field on error)
- Minimum processing delay mode available on XIP-3901-FS
- Audio/video deglitcher to handle video hot switches at the input
- Broadcast-quality color conversion (between ITU-R BT.709 and ITU-R BT.2020)
- SDR/HDR optional processing support HLG, PQ, and S-Log3/S-Gamut3 formats
- Selection between GV LUTs, BBC LUTs v1.4, or User Custom LUTs
- External reference or URS frame reference
- Embedded audio and metadata delay and synchronization
- Individual application licensed, purchased as needed
- Rapid switching between applications

XIP-3901 -UC / -DC / -FS Supported Video Formats

APPLICATIONS:	XIP-3901-UC	XIP-3901-DC	XIP-3901-FS
Output Format	720p50/59 1080i50/59 1080p50/59 A 1080p50/59 B DL 2160p50/59 Mode 1 Quad Link 3G 50/59 A Quad Link 3G 50/59 B	720p50/59 1080i50/59 1080p50/59 A 1080p50/59 B DL 2160p50/59 Mode 1 Quad Link 3G 50/59 A Quad Link 3G 50/59 B	720p50/59 1080i50/59 1080p50/59 A 1080p50/59 B DL 2160p50/59 Mode 1 Quad Link 3G 50/59 A Quad Link 3G 50/59 B
Input Format	720p50/59 1080i50/59 1080p50/59 A 1080p50/59 B DL 2160p50/59 Mode 1 Quad Link 3G 50/59 A Quad Link 3G 50/59 B	720p50/59 1080i50/59 1080p50/59 A 1080p50/59 B DL 2160p50/59 Mode 1 Quad Link 3G 50/59 A Quad Link 3G 50/59 B	720p50/59 1080i50/59 1080p50/59 A 1080p50/59 B DL 2160p50/59 Mode 1 Quad Link 3G 50/59 A Quad Link 3G 50/59 B

Figure 2-1: Supported Video Formats for XIP-3901 -UC / -DC / -FS Applications

Note: 50/59.94 Hz frame rate conversion is not supported.

Functional Block Diagrams

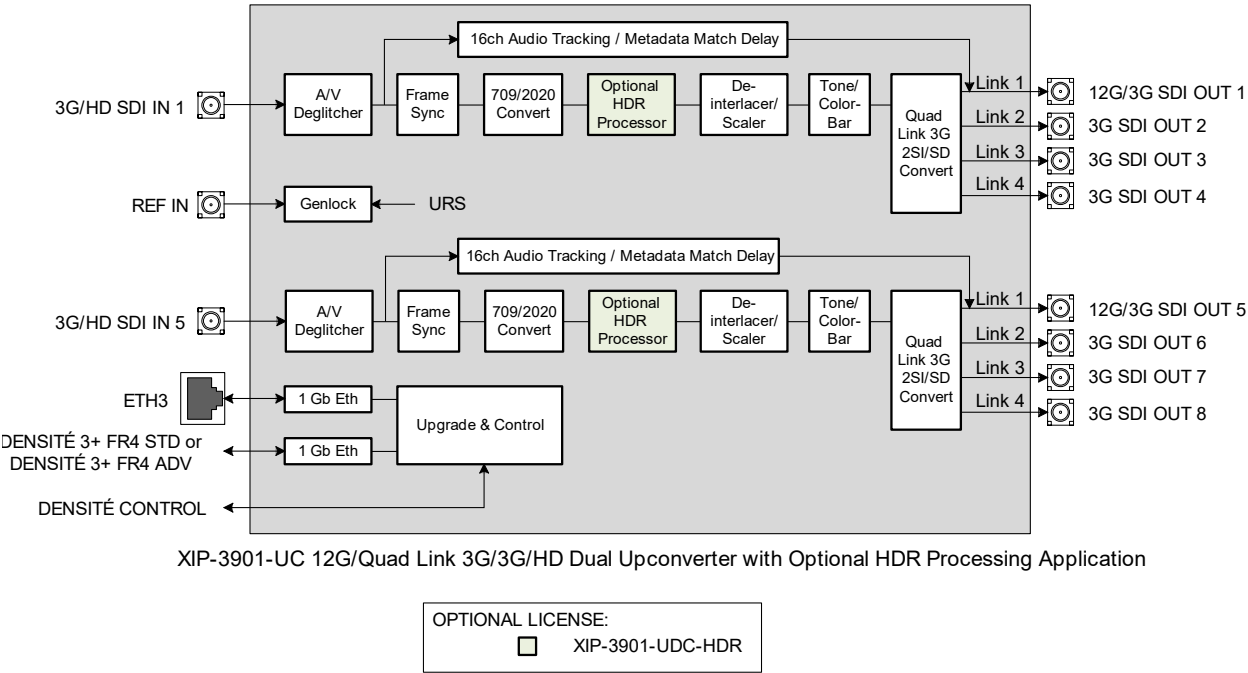

XIP-3901-UC 12G/Quad Link 3G/3G/HD Dual Upconverter with Optional HDR Processing Application

OPTIONAL LICENSE:
 XIP-3901-UDC-HDR

Figure 2-2: XIP-3901-UC Functional Block Diagram

Applications

XIP-3901-UDC-IP Applications

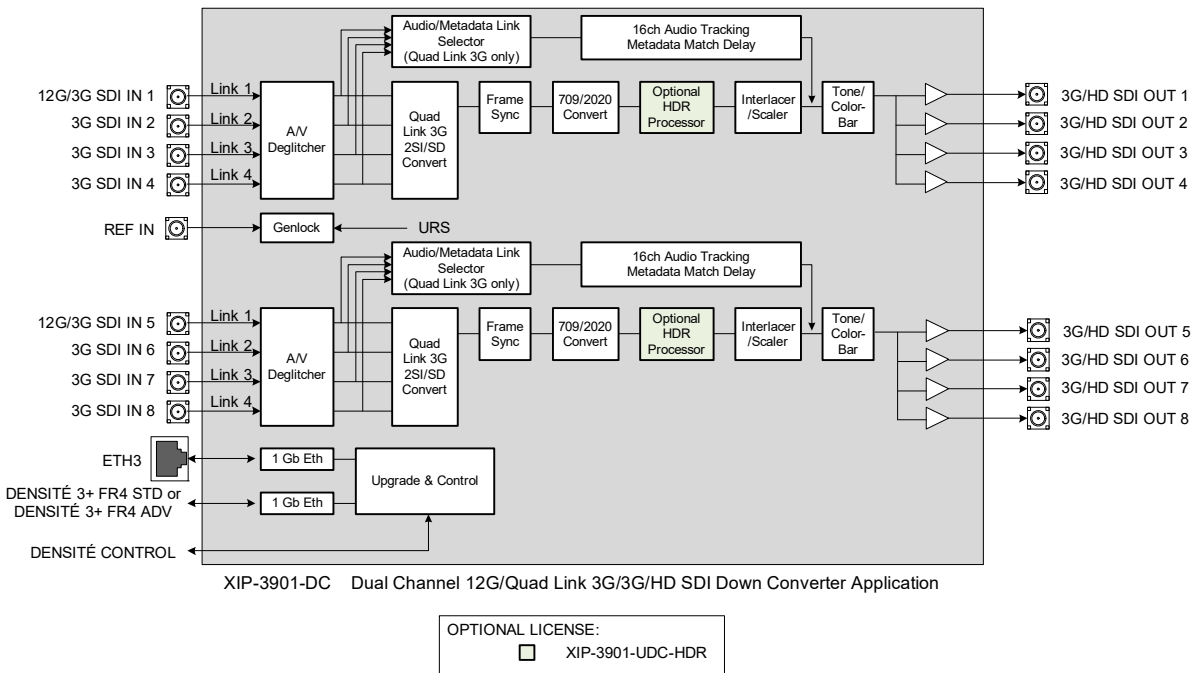

Figure 2-3: XIP-3901-DC Functional Block Diagram

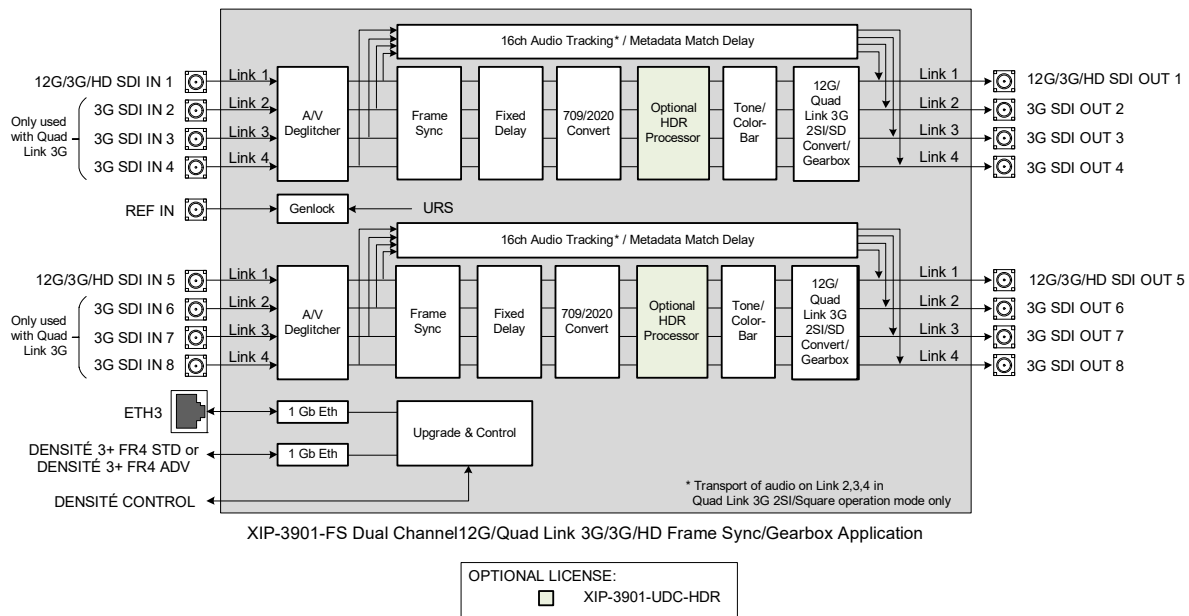

Figure 2-4: XIP-3901-FS Functional Block Diagram

XIP-3901-UDC-IP Applications

The XIP-3901-UDC-IP is a dual-channel 4K UHD broadcast quality format converter with optional HDR and Audio processor supporting IP with dual 25GbE I/O. Based on open standards, this IP edge processing application is compliant to SMPTE ST 2110 suite of standards and JT-NM TR-1001 technical recommendation for easy integration in a

broadcast network production environment as confirmed by our successful participation in **JT-NM Tested** events in August 2019 and March 2020.



The **XIP-3901-UDC-IP** integrates all the video processing function to perform up/down/cross-conversion needed to maintain the chosen output formatting, irrespective of whether the input is HD 720p, 1080i, 1080p or UHD 2160p. High quality up/down/cross-conversion is performed at both 50 and 59.94 Hz, based on multiple sophisticated processing technologies. These include detail enhancement, pixel-based de-interlacing, and advanced motion adaptive de-interlacing and anti-ringing.

The XIP-3901-UDC-IP supports processing of common film rates 23.98p and 29.97p Hz to and from 59.94 Hz material and offers timecode selection either directly from the PTP source or the SMPTE ST 2110-40 stream for processing and regeneration.

The optional HDR processor, **XIP-3901-UDC-HDR**, allows conversion between SDR and HDR formats and wide color gamut BT.709 and BT.2020, supporting HLG (ITU-R BT.2100), PQ (ITU-R BT.2100), and SLog3/SGamut3 formats. In addition to the Grass Valley LUTs, you can select BBC LUTs v1.4 or you can choose your own Custom LUTs compliant to Adobe cube file v1.0 for fully flexible HDR processing. The HDR processor operates in full 10-bit video signals with the ability to pass sub-blacks and super-whites in SMPTE Narrow video signals and the support of SMPTE Full in PQ and S-Log3 signals.

Four streams of 2110-30/31 audio conforming to Level A and Level C is supported per video channel, giving a total of 228 channels of audio with automatic delay to keep lip sync. The **XIP-3901-UDC-AUD** option gives advanced processing control with audio level, delay, up & down-mixing, and shuffling for additional flexibility.

The XIP-3901-UDC-IP can be configured, controlled and monitored by GV Orbit from Grass Valley taking advantage of its many features and functions specifically crafted to make IP easy. It can also be configured and controlled from iControl systems.

Based on the proven Densité modular framework of over 100 cards, the flexible, space-efficient XIP-3911 and XIP-3901 agile processing platforms can accommodate a gradual adoption of different production elements into 1080p and 4K UHD broadcasting workflows — and it enables dual HDR/SDR production — all while protecting your investment in installed equipment. With flexibility to configure up to 12 XIP-3901 dual-channel processing applications per Densité 3+ FR4 frame, the Densité platform scales to a market-leading density of 24 4K UHD processors with HDR conversions in a 4 RU frame. This means space and cost-efficient scaling for today and tomorrow.

XIP-3901-UDC-IP Key Features

- Independent dual-channel UHD up/down/cross IP video processor
- Additional HD Monitoring output on the first processing channel
- ST 2110-20 Video with UHD over single-stream
- ST 2110-21 Wide/Narrow profile receivers and Narrow senders

- ST 2110-30 PCM Audio
- ST 2110-31 AES3 Transparent Transport
- ST 2110-40 Metadata associated with ST 2110-20 video stream
- ST 2022-7 Class A & D seamless protection switching of IP streams.
- ST 2059-1 & -2 Precision Time Protocol with Best Master Clock Algorithm
- NMOS IS-04 discovery and registration with group hint tag support.
- NMOS IS-05 device connection management
- In-band or out-of-band control of NMOS
- Support of DHCP, LLDP and DNS-SD for easy IP configuration
- Video proc features include: gain, offset, hue, horizontal and vertical picture enhancement during downconversion, RGB color corrector, and gamut legalization
- XIP-3901-UDC-HDR option provides HDR conversion supporting both Wide Color Gamut BT.709/ BT.2020 and High Dynamic Range: HLG, PQ and S-Log3.
 - All processing operates in full 10-bit video signals with ability to pass sub-blacks and super-whites in SMPTE narrow video.
 - Choice between Grass Valley conversions algorithms, BBC HLG LUT v1.4 and user defined 3D-LUT support.
 - ITU R BT 2111 HLG/PQ Color bar test patterns
- Four ST 2110-30/31 Level A and C audio stream per processing channels.
- XIP-3901-UDC-AUD option provides 228 channels audio processors with level, delay, up/down mixing and 2:1 mixer/shuffling.
- Dual SFP28 Flexible Ethernet for 25GigE SFP+ cage:
 - **SFP-25G-SR** for short-range multi-mode optical connectors,
 - **SFP-25G-LR** for long range single-mode optical connectors,
 - Active optical cables and optical transceiver.
- Both FEC74 (CL74 Fire Code) and FEC108 (Reed Solomon IEEE) Forward Error Correction are supported.
- GV Orbit or iControl for configuration, control, and monitoring.

XIP-3901-UDC-IP Supported Video Formats

The XIP-3901-UDC-IP supports the following ST 2110-20 Single-Stream formats. In addition the XIP-3901-UDC-IP supports processing of common film rates 23.98p and 29.97p Hz to and from 59.94 Hz material.

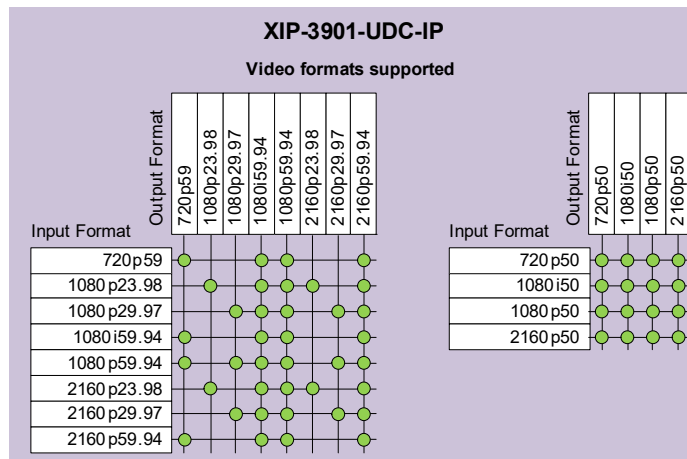

Figure 2-5: Supported Video Formats for XIP-3901-UDC-IP Applications

Optional XIP-3901-UDC-IP Application Audio processing, Down/Up Mix, Shuffling

The following audio processing features are available with the XIP-3901-UDC-AUD option.

- Audio probing (audio presence/ audio type)
- Input mixer
- Upmix
- Downmix
- Fixed delay
- Level & Phase invert
- Output audio: mixer & shuffler

See [Options Panel](#), on page 176 for how to enable this option.

Functional Block Diagram

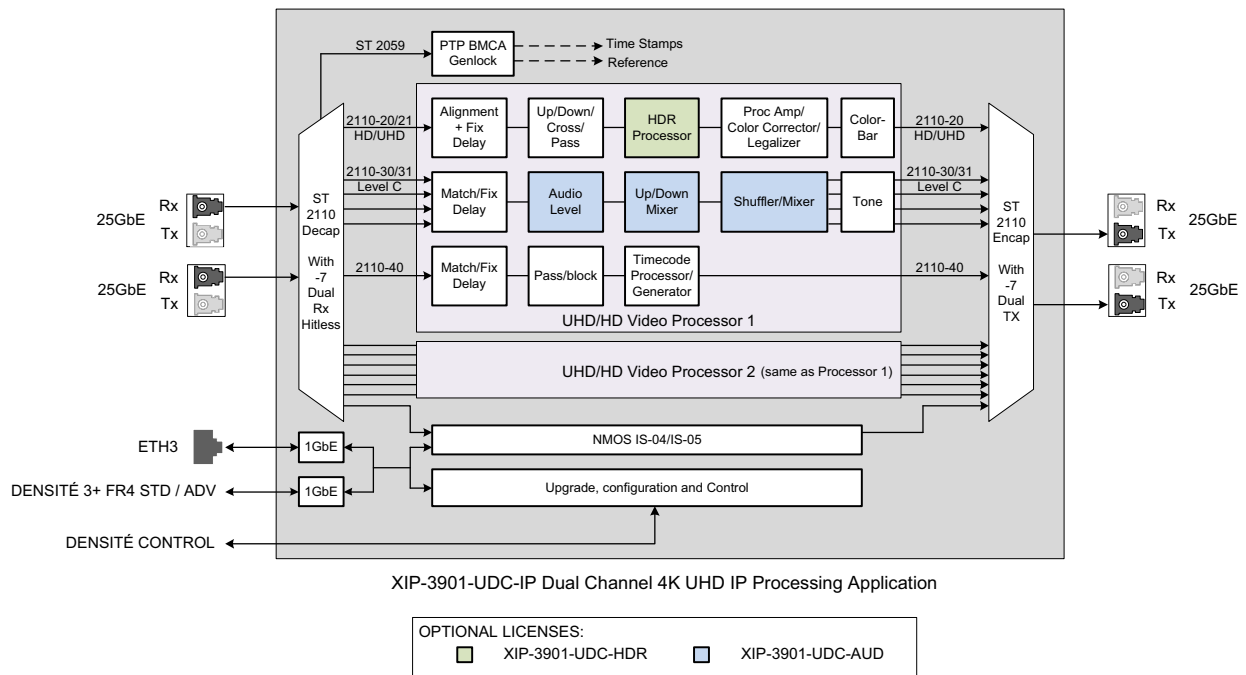

Figure 2-6: XIP-3901-UDC-IP Functional Block Diagram

XIP-3901-UDC-IF v4.0 Application

The XIP-3901-UDC-IF application from Grass Valley has two operating modes: SDI Only or SDI and IP (hybrid) for deployment flexibility and to provide a bridge to an all IP work-flow.

The XIP-3901-UDC-IF has optional HDR and audio processors and in addition allows the application to be configured as a dual-channel 4K UHD or quad-channel HD broadcast-quality format converter.



Figure 2-7: XIP-3901-UDC-IF Operating in SDI Only Mode



Figure 2-8: XIP-3901-UDC-IF Operating in SDI and IP Hybrid Mode



Figure 2-9: XIP-3901-UDC-IF Operating in SDI and IP Hybrid Mode with IP Audio Inputs

The XIP-3901-UDC-IF provides frame synchronization and video processing functions to perform up/down/crossconversion needed to maintain the chosen output format, irrespective of whether the input is HD 720p, 1080i, 1080p or UHD 2160p. High-quality

up/down/cross-conversion is performed at both 50 and 59.94 Hz, based on multiple sophisticated processing technologies. These include detail enhancement, pixel-based de-interlacing, and advanced motion adaptive de-interlacing and anti-ringing. In addition, a set of video processing functions provide operators control of proc amp adjustment, signal enhancement, color correction and legalization of both paths.

All processing channels on the XIP-3901-UDC-IF can be genlocked to PTP, an external reference, or to the frame reference internal URS signals. In the absence of a valid video input, the video output signal will freeze on the last good frame. Each processing channel is able to delay 12G/3G/HD embedded audio and metadata to maintain synchronization with the video and offers a frame buffer which allows an additional delay increase up to 6 frames/fields.

In a hybrid SDI-IP environment, the XIP-3901-UDC-IF dual 25 GbE I/O supports the SMPTE ST 2110 suite of standards and JT-NM TR-1001-1 technical recommendation for easy integration in a broadcast network environment.

The optional HDR processor, XIP-3901-UDC-HDR, allows conversion between SDR and HDR formats and wide color gamut BT.709 and BT.2020, supporting HLG (ITU-R BT.2100), PQ (ITU-R BT.2100), and S-Log3/S-Gamut3 formats. The HDR processor supports 33 point Tetrahedral 3D LUT Interpolation and in addition to the Grass Valley LUTs, you can select from the built-in BBC LUTs v1.5, NBCU or you can choose your own custom LUTs compliant to Adobe cube file v1.0 for fully flexible HDR processing. This processor operates in full 10-bit video with the ability to pass sub-blacks and super-whites in SMPTE Narrow video signals and the support of SMPTE Full in PQ and S-Log3 signals.

Four output streams of SMPTE ST 2110-30/31 audio conforming to Level A and Level C are supported per video channel. The XIP-3901-UDC-AUD option adds four audio input streams with advanced processing control for a total of 256 channels of audio with automatic delay to keep lip sync — with audio level, delay, shuffling, up-mixing, and down-mixing 5.1.4 or 5.1 surround sound signal to a stereo channel pair.

The XIP-3901-UDC-IF can be configured, controlled and monitored by Grass Valley's GV Orbit, taking advantage of many features and functions specifically crafted to make IP easy. It can also be configured and controlled from iControl systems.

XIP-3901-UDC-IF Key Features

- Independent dual-channel 4K UHD or quad-channel HD broadcast-quality up/down/cross video processor
- 12G 2160p, 3G 1080p and HD 1080i/720p SDI inputs and outputs
- Integrated frame synchronizer with additional video delay programmable to 6 frames
- Audio/video deglitcher to handle video hot switch at the input
- Video proc including: gain, offset, hue, horizontal and vertical picture enhancement during downconversion, RGB color corrector and gamut legalization
- PTP, external reference, or dual URS frame reference supported
- Embedded audio and metadata delay and synchronization
- IP output available on dual 25 GigE IP media network interfaces:
 - SMPTE ST 2110-20/21 video outputs with associated SMPTE ST 2110-40 metadata streams

- Four SMPTE ST 2110-30/31 Level A, B, C audio stream outputs per processing channel
- SMPTE ST 2022-7 for seamless protection of IP streams
- JT-NM TR-1001-1 compliant including NMOS IS-04/IS-05
- SMPTE ST 2059-1/-2 PTP with BMCA–Media interfaces supports AOC cable, Short and Long Reach fiber
- Both FEC74 (CL74 Fire Code) and FEC108 (Reed Solomon IEEE) Forward Error Correction are supported
- XIP-3901-UDC-HDR option provides HDR conversion supporting both Wide Color Gamut BT.709/ BT.2020 and High Dynamic Range: HLG, PQ and S-Log3
 - Agile HDR conversion based on input signal colorimetry
 - Supports 33 point Tetrahedral 3D LUT Interpolation with choice among Grass Valley conversion algorithms, built-in BBC LUTs v1.5, NBCU LUTs, or user defined custom LUTs compliant to Adobe cube file v1.0.
 - All processing operates in full 10-bit video signals with ability to pass sub-blacks and super-whites in SMPTE narrow video
 - ITU R BT 2111 HLG/PQ color bar test patterns
- XIP-3901-UDC-AUD option adds four SMPTE ST 2110-30/31 audio input streams per processing channel, and provides 256 channel audio processors with level, delay, 2:1 mixer/shuffling, up-mixing, and down-mixing of 5.1.4 or 5.1 surround sound signal to a stereo channel pair.
- GV Orbit for configuration, control and monitoring
- Individual XIP-3901 applications licensed, purchased as needed
- Rapid switching between XIP-3901 applications
- The XIP-3901-UDC-IF is also supported by the ATP-2000 Touch Panel with GV Orbit Dynamic Orchestration where all video processing parameters of both paths can be controlled from a touch panel interface

XIP-3901-UDC-IF Supported Video Formats

The XIP-3901-UDC-IF supports the following video formats conversion.

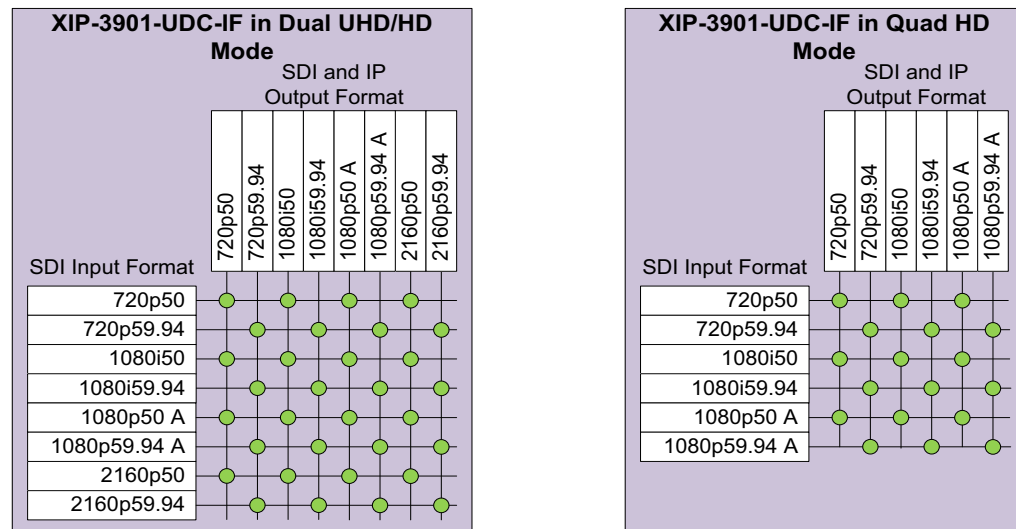

Figure 2-10: Supported Video Formats for XIP-3901-UDC-IF Application

Optional XIP-3901-UDC-IF v4.0 Application Audio processing, Down/Up Mix, Shuffling

The following audio processing features are available; some require the XIP-3901-UDC-AUD option.

Feature	Always available	XIP-3901-UDC-AUD option enabled
Audio probing (audio presence/ audio type)	●	●
Input mixer		●
Upmix		●
Downmix		●
Fixed delay		●
Level & Phase invert		●
Output audio: mixer & shuffler	●	●

See [Options Panel](#), on page 176 for how to enable this option.

Functional Block Diagram

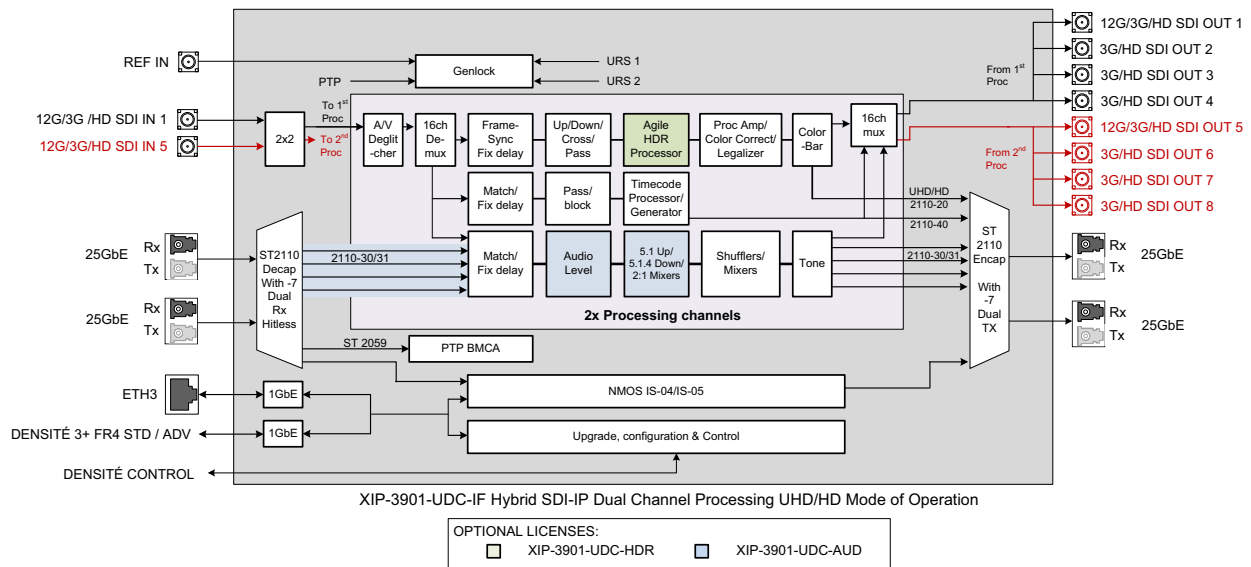

Figure 2-11: XIP-3901-UDC-IF Functional Block Diagram when the **Dual UHD/HD** option for the **Operating Mode** has been selected

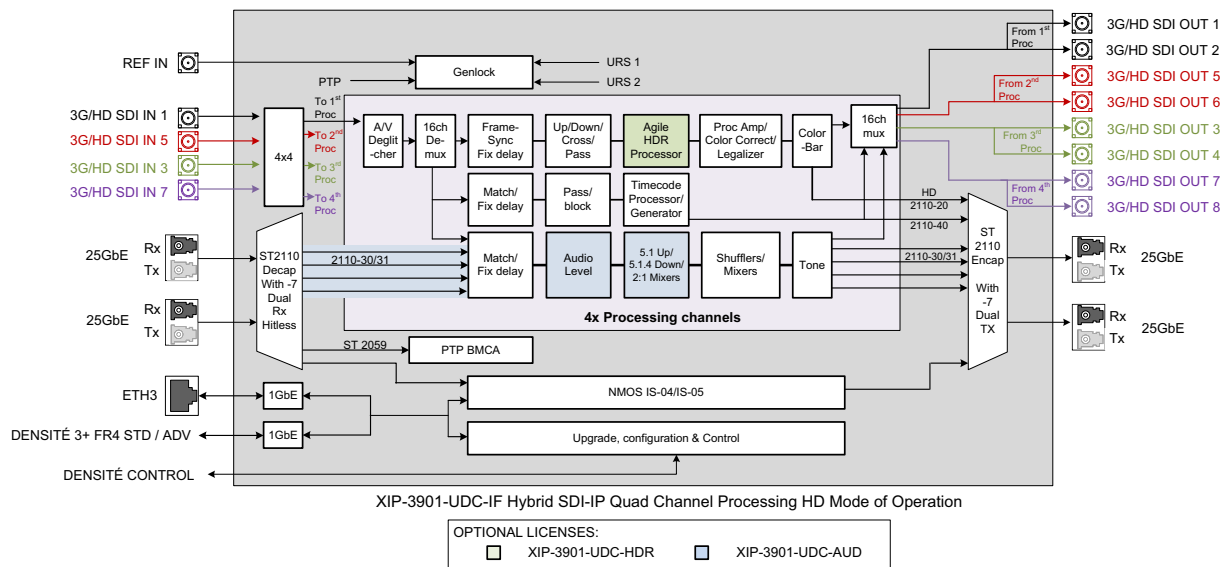

Figure 2-12: XIP-3901-UDC-IF Functional Block Diagram when the **Quad HD** option for the **Operating Mode** has been selected

XIP-3901-GB-IP Application

The XIP-3901-GB-IP is a dual-channel 4K UHD gearbox application for conversion between Quadstream 1080p Two Sample Interleave (2SI) or Square Division Quad Stream (SDQS) and Single-stream 4K UHD supporting IP with dual 25 GbE I/O. Based on open standards, this IP edge gearbox processing application is compliant to the SMPTE ST 2110 suite of

standards and JT-NM TR-1001 technical recommendation for easy integration in a broadcast IP network production environment.

The XIP-3901-GB-IP solves 4K UHD production problems with early IP devices implementing Quad-stream 1080p and SMPTE ST 2110-20 recommendations for Single-stream 2160p, which can be a gap when building a complete end-to-end 4K UHD solution.

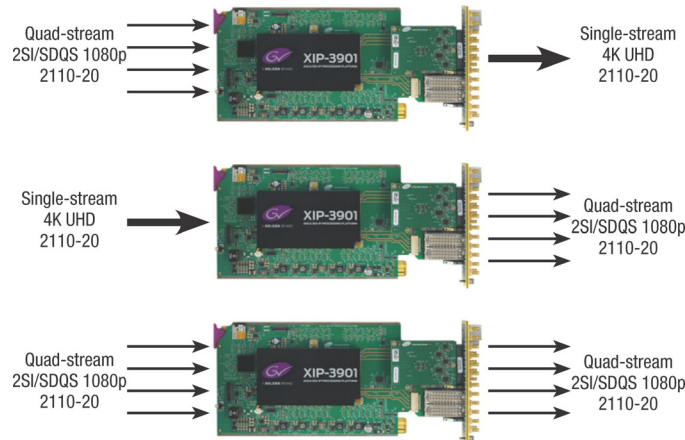

The XIP-3901-GB-IP also supports four streams of SMPTE ST 2110-30/31 audio conforming to Level A and Level C, as well as one stream of SMPTE ST 2110-40 metadata per channel of IP gearbox.

The XIP-3901-GB-IP is configured, controlled and monitored by GV Orbit, taking advantage of its many features and functions specifically crafted to make IP easy. It can also be configured and controlled from iControl systems.

Based on the proven Densité modular framework with over 80 card types, the flexible, space-efficient XIP-3911 and XIP-3901 agile processing platforms can accommodate a gradual adoption of different production elements into 1080p and 4K UHD broadcasting workflows, all while protecting your investment in installed equipment. With flexibility to configure up to 12 XIP-3901 dual-channel processing applications per Densité 3+ FR4 frame, the Densité platform scales to a density of 24 4K UHD processors in a 4 RU frame. This means space and cost-efficient scaling today and tomorrow.

All the processing applications delivered on the XIP-3911 and XIP-3901 platforms allow live productions, either from trucks, venues, stadiums or broadcast facilities to make the most of new UHD and HDR formats. Packing lots of audio/video processing power in a small form factor means considerable savings in terms of space, power and weight.

XIP-3901-GB-IP Key Features

- Independent dual-channel UHD Gearbox IP video processor
- ST 2110-20 Video with UHD over single and quad-1080p streams
- Supports Two Sample Interleave and Square Division
- ST 2110-21 Wide/Narrow profile receivers and Narrow senders
- ST 2110-30 PCM Audio
- ST 2110-31 AES3 Transparent Transport
- ST 2110-40 Metadata associated with ST 2110-20 video stream
- ST 2022-7 Class A & D seamless protection switching of IP streams.

- ST 2059-1 & -2 Precision Time Protocol with Best Master Clock Algorithm
- NMOS IS-04 discovery and registration with group hint tags support.
- NMOS IS-05 device connection management
- In-band or out-of-band control of NMOS
- Support of DHCP, LLDP and DNS-SD for easy IP configuration
- Four ST 2110-30/31 Level A and C audio streams per processing channel.
- Dual SFP28 Flexible Ethernet for 25GigE SFP+ cage:
 - **SFP-25G-SR** for short-range multi-mode optical connectors,
 - **SFP-25G-LR** for long range single-mode optical connectors,
 - Active optical cables and optical transceiver.
- Both FEC74 (CL74 Fire Code) and FEC108 (Reed Solomon IEEE) Forward Error Correction are supported.
- GV Orbit for configuration, control and monitoring

XIP-3901-GB-IP Supported Video Formats

The XIP-3901-GB-IP supports the following video formats conversion.

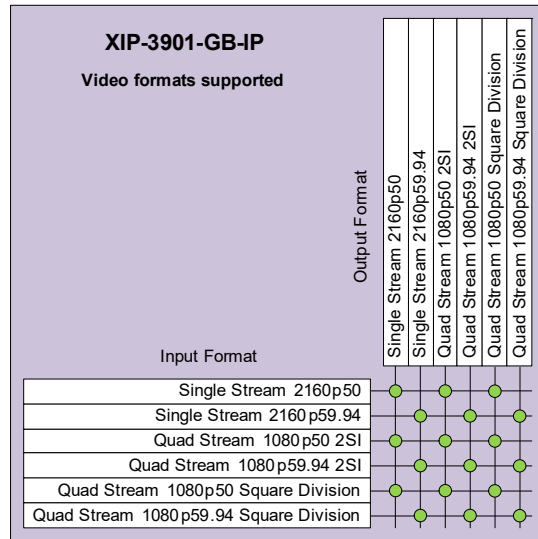

Figure 2-13: Supported Video Formats for XIP-3901-GB-IP Application

Functional Block Diagram

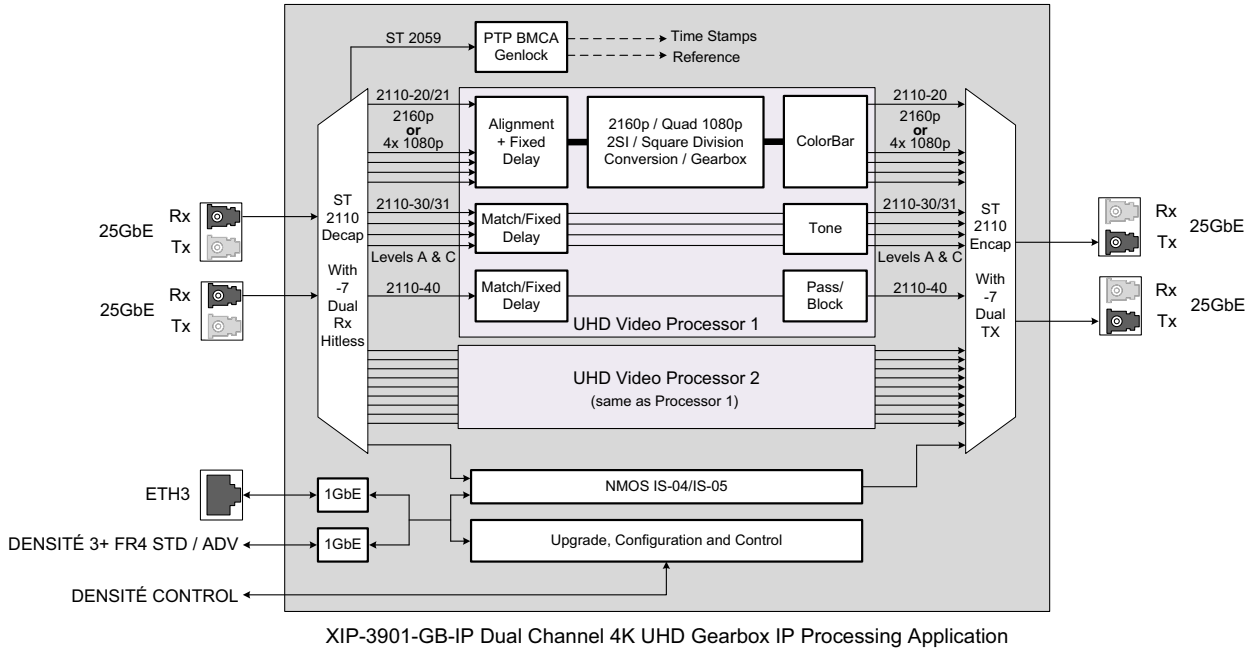

Figure 2-14: XIP-3901-GB-IP Functional Block Diagram

Optional HDR Processing

Optional HDR processing is available for the following applications only:

- XIP-3901-UC / -DC / -FS Application
- XIP-3901-UDC-IP Application
- XIP-3901-UDC-IF Application

The above applications include ITU-R BT.709 and ITU-R BT.2020 color space conversions. The **XIP-3901-UDC-HDR** option adds HDR/SDR up-mapping and down-mapping capabilities, as summarized in the following table:

GV LUT Conversions	BBC LUT	User Defined LUT
BT. 709 BT. 2020	BT.709 HLG BT.2100 SCENE REFERRED	Adobe cube file v1.0 – 33 cube
BT. 709 HLG BT.2100	BT.709 HLG BT.2100 DISPLAY REFERRED	BT. 709 BT. 2020
BT. 709 PQ ST.2100	HLG BT.2110 PQ BT.2110	Narrow Full range
HLG BT.2100 PQ ST.2100	S-Log3 BT.2020 HLG BT.2110	
S-Log3/S-Gamut3 BT. 709		
S-Log3/S-Gamut3 HLG BT.2100		
S-Log3/S-Gamut3 PQ BT.2100		
And ITU R BT 2111 HLG/PQ Color bar test patterns		

Figure 2-15: HDR/SDR Up-mapping and Down-mapping Capabilities for XIP-3901-UC / -DC / -FS & XIP-3901-UDC-IP Applications

For:

- XIP-3901-UC / -DC / -FS Applications, see [Options Panel](#), on page 122.
- XIP-3901-UDC-IP Application and XIP-3901-UDC-IF Application, see [Options Panel](#), on page 176.

XIP-3901-JPEG-XS Application

The XIP-3901-JPEG-XS is an application for the reprogrammable software-defined platforms such as XIP-3911 and XIP-3901 that support multiple channel of HD & UHD encoding/decoding between 2110-20 uncompressed video and 2110-22 high quality compressed video using the JPEG-XS standard. The application provides low latency encoding side while an optional ST-2110 streams alignment is available on the decoding side to match production studio equipment top of frame reference requirement if needed.

This solution offers a bridge between remote contribution network and core production network using ultra-low latency encoding and decoding to efficiently manage network bandwidth over long distance.

Combined with JPEG-XS enabled LDX Cameras, IPVU and GV Orbit, GV remote-integration model reduce the movement of people and equipment; increase the utilization of kit; reduce on-site setup times and maximize the efficient of production teams.

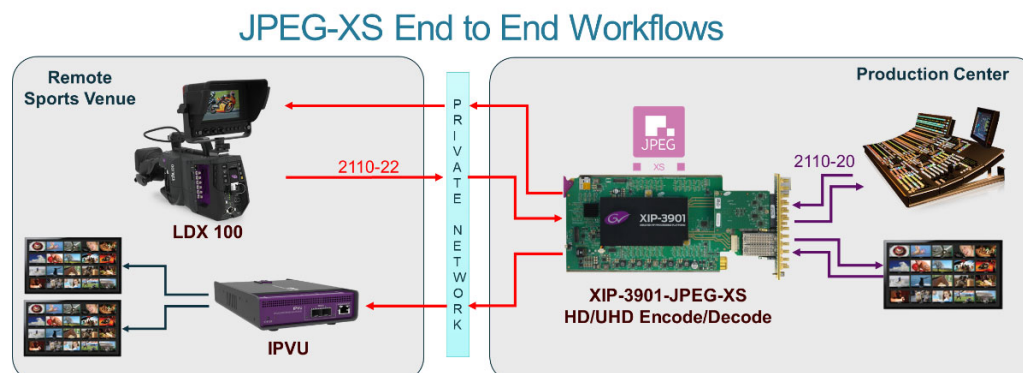

XIP-3901-JPEG-XS Key Features

- XIP-3901 application supporting ST-2110 and JT-NM TR-1001.
- SDI output on the Decoder paths.
- Ultra-low latency codec based on IntoPix's ISO standardized JPEG-XS.
- User selectable compression ratio from 6:1 to 36:1. (6:1 is nearly-lossless, 10:1 is visually lossless.)
- Support HD (720p/1080i/1080p) and UHD (2160p) video resolution, 50 and 59.94hz.
- 3 configurations are available that optimizes number of encoding/decoding paths:

Mode	Encoder paths	Decoder paths	Uncompressed input type	Uncompressed Output type
1	2 HD/UHD	2 HD/UHD	ST-2110	SDI + ST-2110
2	8 HD	0 HD	ST-2110	n/a
3	0 HD	8 HD	n/a	SDI + ST-2110

- Complete integration with GV Orbit for configuration, control and monitoring.
- New HTML 5 based control interface.

XIP-3901-JPEG-XS Functional Block Diagram

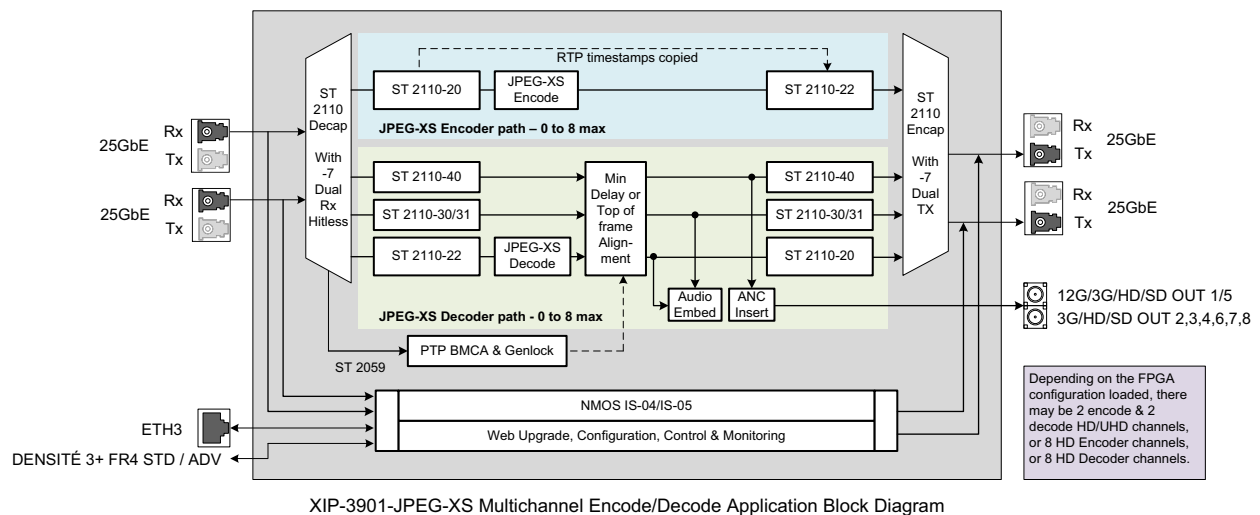

Figure 2-16: XIP-3901-JPEG-XS Functional Block Diagram

XIP-3901-ASI Application

The XIP-3901-ASI application facilitates cable, satellite and IPTV operators' migration towards IP infrastructures by offering a flexible highly integrated DVB-ASI/IP bidirectional gateway that can bridge any type of MPEG transport stream from/to IP networks. The high density allows 192 (96 ASI->IP and 96 IP->ASI) gateways per 4 RU Densité 3+ FR4 frame, saving substantial rack space in high channel count environments. Its scalability through modularity is the ideal solution to address increasing TV channel lineups.

The dual Ethernet SFP sockets allow fiber or electrical connectivity to the main and backup video backbone to provide complete redundancy of MPEG transport streams using the

SMPTE ST-2022-7 Seamless Protection Switching. Each DVB-ASI I/O can also be paired in redundant mode. Combined together the IP and DVB-ASI redundant ports offer a robust solution to ensure uninterrupted services.

The XIP-3911 and XIP-3901 Agile Processing Platforms also provide long-term value by protecting a customer's CAPEX investment in current HD and UHD SDI and now IP infrastructure. The application-based licensing model adapts the XIP-3911 and XIP3901 to new workflows with different software applications resulting in a truly virtualized hardware environment.

The XIP-3901-ASI is configured, controlled and monitored by GV Orbit from Grass Valley, taking advantage of many features and functions specifically crafted to make IP easy. It can also be configured using the on-board HTML5 web interface and documented Rest API.

Typical Applications

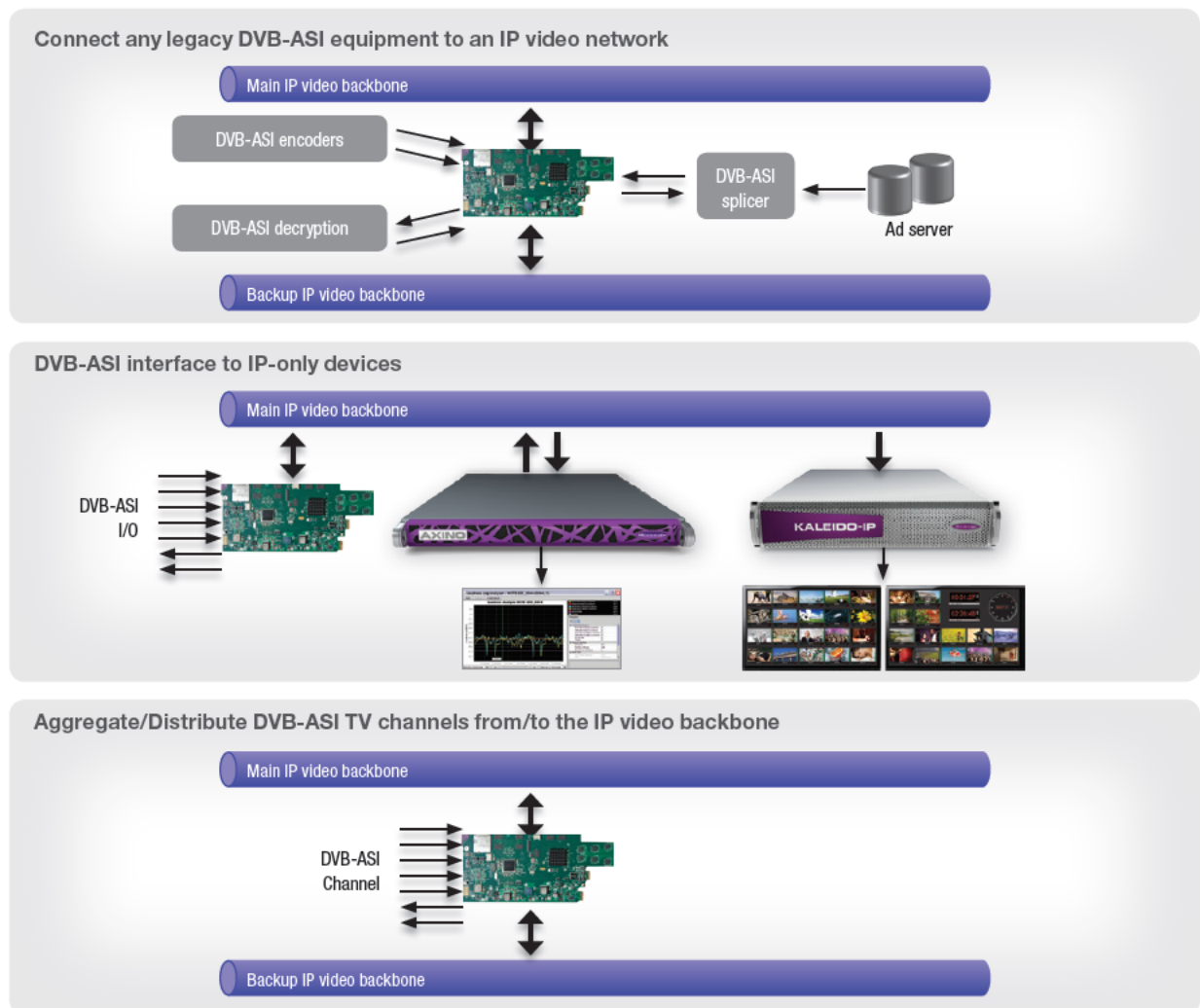

XIP-3901-ASI Key Features

- Very high density with 16 gateways per card/192 gateways per 4RU Densité 3+ FR4 frame.
- Support up to 8 DVB-ASI inputs and 8 DVB-ASI outputs
- Handle most demanding streams:
 - Up to 213 Mb/s per DVB-ASI
 - Total of 1.7 Gb/s on 10/25GbE Ethernet device
- Convert legacy ASI devices to IP and IP to ASI conversions
- Flexible IP connectivity through two distinct SFP ports for optical or electrical modules:
 - 10GbE Optical SFP
 - 25GbE Optical SFP
 - Both FEC74 (CL74 Fire Code) and FEC108 (Reed Solomon IEEE) Forward Error Correction are supported on 25GbE interfaces
- SMPTE ST 2022-1 FEC for real-time Video/Audio transport over IP Networks
- SMPTE ST 2022-2 Unidirectional Transport of Constant Bit Rate MPEG-2 Transport Streams over IP Network
- SMPTE ST 2022-3 Unidirectional Transport of Variable Bit Rate MPEG-2 Transport Streams on IP Networks
- SMPTE ST 2022-7 Class B seamless protection switching of IP streams
- UDP/RTP encapsulation of 7 TS/IP packet
- Support of multicast traffic control using IGMPv3 MSM/SSM
- Network Jitter removal
- Support of DHCP, LLDP for easy IP configuration
- HTML5 web-based configuration interface
- In-band or out-of-band control, Web Interface and RestAPI
- Open configuration management & monitoring with the Rest API
- Complete integration with GV Orbit for configuration, control, monitoring and routing
- Dynamic endpoint control (multicast join/leave) and monitoring by GV Orbit
- Individual XIP-3901 application licensed, purchased as needed
- Rapid switching between XIP-3901 applications

XIP-3901-ASI Functional Block Diagram

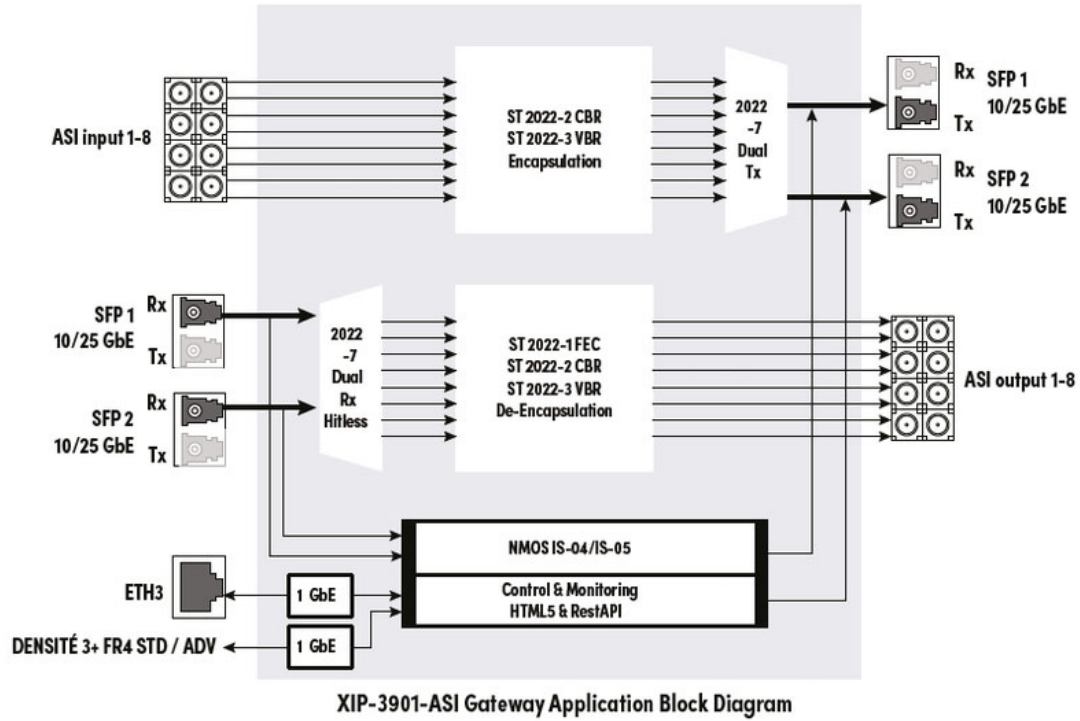

Figure 2-17: XIP-3901-ASI Functional Block Diagram

3

XIP-3911 & XIP-3901 Installation and Operation

XIP-3901-UC, XIP-3901-DC, or XIP-3901-FS	XIP-3901-UDC-IP	XIP-3901-UDC-IF	XIP-3901-GB-IP	XIP-3901-JPEG XS, or XIP-3901-ASI
●	●	●	●	●

Front Card-edge Interface

The front card-edge of the XIP-3911 or XIP-3901 incorporates two elements:

- Status LED (see [Card-edge Status LED](#), on page 41)
- Select button (see [Local Control Using the Densité Frame Control Panel](#), on page 67)

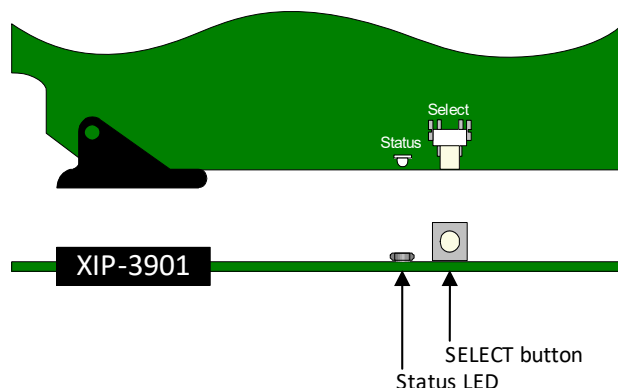

Fig. 3-1: Front Card-edge Layout

For further information about how to troubleshoot an issue, see [Troubleshooting](#), on page 333.

Card-edge Status LED

The status LED is located on the front card-edge of the XIP-3911 or XIP-3901 and is visible through the front access door of the Densité-3 frame. This LED indicates the status of the XIP-3911 or XIP-3901 using different colors and by flashing/steady illumination.

The table shows how the various error conditions that can be flagged on the XIP-3911 or XIP-3901 affect the LED status.

- If a cell is gray, the LED cannot be configured to assume that status.
- If more than one LED status is possible for a particular error condition, the status is configurable. See [Alarm Config Panel](#), on page 255 for details.
- The factory default status, if available, is marked with a ● symbol.

The LED will always show the most severe error status that has been detected and that it is configured to display. In the chart, error severity increases from left to right. Green represents no error/disabled, and flashing red represents the most severe error.

Note: If the LED is flashing yellow, the card has been selected for local control using the Densité frame control panel. See [Local Control Using the Densité Frame Control Panel](#), on page 67 for details.

Error Condition XIP-3911 or XIP-3901 Card LED Status	XIP-3911 or XIP-3901 Card									LED Status (default severity)			
	-UC	-DC	-FS	-UDC-IF	-UDC-IP	-GBIP	-JPEG-XS, -ASI			Green	Yellow	Red	Flashing Red
							2DEC/2ENC	8 DEC	8 ENC				
Hardware failure	•			•	•	•	•	•	•				•
Wrong or missing rear connector panel	•			•	•	•	•	•	•				•
IN1/5 – No carrier	•	•	•	•									•
IN1/5 – Unsupported	•	•	•	•									•
IN1/5 – Video/TRS error	•	•	•	•									•
IN1/5 – Reference mismatch	•	•	•	•									•
IN2/3/4/6/7/8 – No carrier		•	•										•
IN2/3/4/6/7/8 – Unsupported		•	•										•
IN2/3/4/6/7/8 – Video/TRS error		•	•										•
IN2/3/4/6/7/8 – Reference mismatch		•	•										•
IN1 to IN4– Quad Link 3G ALIGN		•	•										•
IN5 to IN8 – Quad Link 3G ALIGN		•	•										•
Channel 1/2 – Reference present	•	•											•
Channel 1/2 – Reference supported	•	•											•
Channel 1/2 – Reference locked	•	•											•
Channel 1 to 2 – Color Bars & Tone enabled	•	•	•	•	•	•	•	•	•		•		
Channel 2 to 4 – Color Bars & Tone enabled							•	•	•		•		
Channel 5 to 8 – Color Bars & Tone enabled								•	•		•		

Error Condition XIP-3911 or XIP-3901 Card LED Status	XIP-3911 or XIP-3901 Card									LED Status (default severity)			
	-UC	-DC	-FS	-UDC-IF	-UDC-IP	-GBIP	-JPEG-XS, -ASI			Green	Yellow	Red	Flashing Red
							2DEC/2ENC	8 DEC	8 ENC				
ETH1/ETH2 Link up				•	•	•	•	•	•			•	
ETH3/FRM Link up				•	•	•	•	•	•	•			
ETH1/ETH2 SFP Presence				•	•	•	•	•	•			•	
ETH1/ETH2 SFP Alarm Rx Power Low/High				•	•	•	•	•	•			•	
ETH1/ETH2 SFP Alarm Tx Power Low/High				•	•	•	•	•	•			•	
ETH1/ETH2 SFP Alarm Tx Bias Low/High				•	•	•	•	•	•			•	
ETH1/ETH2 SFP Alarm Vcc Low/High				•	•	•	•	•	•			•	
ETH1/ETH2 SFP Alarm Temperature Low/High				•	•	•	•	•	•			•	
ETH1/ETH2 SFP Warning Rx Power Low/High				•	•	•	•	•	•		•		
ETH1/ETH2 SFP Warning Tx Power Low/High				•	•	•	•	•	•		•		
ETH1/ETH2 SFP Warning Tx Bias Low/High				•	•	•	•	•	•		•		
ETH1/ETH2 SFP Warning Vcc Low/High				•	•	•	•	•	•		•		
ETH1/ETH2 SFP Warning Temperature Low/High				•	•	•	•	•	•		•		
PTP Locked				•	•	•	•	•	•			•	
NMOS registered				•	•	•	•	•	•			•	
Channel 1 to 2 - Receivers - Video 1 ST 2110-20 - Stream ETH1/ETH2					•	•			•			•	
Channel 1 to 2 - Receivers - Video 1 ST 2110-20 - Media					•	•			•			•	
Channel 1 to 2 - Receivers - Video 1 ST 2110-20 - Redundancy					•	•			•			•	
Channel 1 to 2 - Receivers - Video 2 to 4 ST 2110-20 - Stream ETH1/ETH2						•						•	

XIP-3911 & XIP-3901 Installation and Operation
 Card-edge Status LED

Error Condition XIP-3911 or XIP-3901 Card LED Status	XIP-3911 or XIP-3901 Card									LED Status (default severity)			
	-UC	-DC	-FS	-UDC-IF	-UDC-IP	-GBIP	-JPEG-XS, -ASI			Green	Yellow	Red	Flashing Red
							2DEC/ 2ENC	8 DEC	8 ENC				
Channel 1 to 2 - Receivers - Video 2 to 4 ST 2110-20 - Media						.						.	
Channel 1 to 2 - Receivers - Video 2 to 4 ST 2110-20 - Redundancy						.						.	
Channel 3 to 4 - Receivers - Video 1 ST 2110-20 - Stream ETH1/ETH2							.		.			.	
Channel 3 to 4 - Receivers - Video 1 ST 2110-20 - Media							.		.			.	
Channel 3 to 4 - Receivers - Video 1 ST 2110-20 - Redundancy							.		.			.	
Channel 5 to 8 - Receivers - Video 1 ST 2110-20 - Stream ETH1/ETH2									.			.	
Channel 5 to 8 - Receivers - Video 1 ST 2110-20 - Media									.			.	
Channel 5 to 8 - Receivers - Video 1 ST 2110-20 - Redundancy									.			.	
Channel 1 to 2 - Receivers - Video 1 ST 2110-22 - Stream ETH1/ETH2							.	.				.	
Channel 1 to 2 - Receivers - Video 1 ST 2110-22 - Media							.	.				.	
Channel 1 to 2 - Receivers - Video 1 ST 2110-22 - Redundancy							.	.				.	
Channel 3 to 8 - Receivers - Video 1 ST 2110-22 - Stream ETH1/ETH2								.				.	
Channel 3 to 8 - Receivers - Video 1 ST 2110-22 - Media								.				.	

Error Condition XIP-3911 or XIP-3901 Card LED Status	XIP-3911 or XIP-3901 Card									LED Status (default severity)			
	-UC	-DC	-FS	-UDC-IF	-UDC-IP	-GBIP	-JPEG-XS, -ASI			Green	Yellow	Red	Flashing Red
							2DEC/ 2ENC	8 DEC	8 ENC				
Channel 3 to 8 - Receivers - Video 1 ST 2110-22 - Redundancy													
Channel 1 to 2 - Receivers - Meta 1 ST 2110-40 - Stream ETH1/ETH2													
Channel 1 to 2 - Receivers - Meta 1 ST 2110-40 - Media													
Channel 1 to 2 - Receivers - Meta 1 ST 2110-40 - Redundancy													
Channel 3 to 8 - Receivers - Meta 1 ST 2110-40 - Stream ETH1/ETH2													
Channel 3 to 8 - Receivers - Meta 1 ST 2110-40 - Media													
Channel 3 to 8 - Receivers - Meta 1 ST 2110-40 - Redundancy													
Channel 1 to 2 - Receivers - Audio 1 ST 2110-3x - Stream ETH1/ETH2													
Channel 1 to 2 - Receivers - Audio 1 ST 2110-3x - Media													
Channel 1 to 2 - Receivers - Audio 1 ST 2110-3x - Redundancy													
Channel 1 to 2 - Receivers - Audio 2 to 3 ST 2110-3x - Stream ETH1/ETH2													
Channel 1 to 2 - Receivers - Audio 2 to 3 ST 2110-3x - Media													
Channel 1 to 2 - Receivers - Audio 2 to 3 ST 2110-3x - Redundancy													

XIP-3911 & XIP-3901 Installation and Operation
 Card-edge Status LED

Error Condition XIP-3911 or XIP-3901 Card LED Status	XIP-3911 or XIP-3901 Card									LED Status (default severity)			
	-UC	-DC	-FS	-UDC-IF	-UDC-IP	-GBIP	-JPEG-XS, -ASI			Green	Yellow	Red	Flashing Red
							2DEC/ 2ENC	8 DEC	8 ENC				
Channel 3 to 8 - Receivers - Audio 1 ST 2110-3x - Stream ETH1/ETH2													
Channel 3 to 8 - Receivers - Audio 1 ST 2110-3x - Media													
Channel 3 to 8 - Receivers - Audio 1 ST 2110-3x - Redundancy													
Channel 1 to 2 - Inputs_Outputs - Video In													
Channel 3 to 8 - Inputs_Outputs - Video In													
Channel 1 to 2 - Metadata - Packet 1 to 8 Presence													
Channel 1 to 2 - Senders - Video 1 ST 2110-20 - Stream ETH1/ETH2													
Channel 1 to 2 - Senders - Video 2 to 4 ST 2110-20 - Stream ETH1/ETH2													
Channel 3 to 8 - Senders - Video 1 ST 2110-20 - Stream ETH1/ETH2													
Channel 1 to 2 - Senders - Video 1 ST 2110-22 - Stream ETH1/ETH2													
Channel 3 to 8 - Senders - Video 1 ST 2110-22 - Stream ETH1/ETH2													
Channel 1 to 2 - Senders - Meta 1 ST 2110-40 - Stream ETH1/ETH2													
Channel 3 to 8 - Senders - Meta 1 ST 2110-40 - Stream ETH1/ETH2													

Error Condition XIP-3911 or XIP-3901 Card LED Status	XIP-3911 or XIP-3901 Card									LED Status (default severity)			
	-UC	-DC	-FS	-UDC-IF	-UDC-IP	-GBIP	-JPEG-XS, -ASI			Green	Yellow	Red	Flashing Red
							2DEC/2ENC	8 DEC	8 ENC				
Channel 1 to 2 - Senders - Audio 1 ST 2110-3x - Stream ETH1/ETH2				
Channel 1 to 2 - Senders - Audio 2 to 4 ST 2110-3x - Stream ETH1/ETH2				
Channel 3 to 8 - Senders - Audio 1 ST 2110-3x - Stream ETH1/ETH2								.				.	

Installation

Fiber Optic Handling

Never assume a fiber is dark. Never look directly into the end of a fiber cable. All people in the area must wear laser safety glasses with side shields. See also [Keep Fiber Connections Clean](#), on page 334.

Getting Organized / Unpacking

Make sure the following items have been shipped with your XIP+3911 & XIP+3901 order. If any of these are missing, contact your distributor or Grass Valley (see [Grass Valley Technical Support](#), on page 354).

Your XIP+3911 & XIP+3901 package includes the following:

- XIP-3911 & XIP-3901 (front and rear modules), as per order
- SFP modules, as per order

Required Tools

In addition to the above, you will need the following tools (field supplied):

- Phillips #2 screwdriver to remove and install rear panels

Required Material

In addition to the above, you will need the following (field supplied):

- Client PC
- Optionally for a multiviewer, display cables /converter (to connect your multiviewer to displays)
- At least one Densité frame with available modular card slots
- Ethernet network connectivity

Installation of the Rear Connector Panel and Card

Grass Valley Densité series cards are each associated with a rear connector panel, which must be installed in the Densité frame before the card can be inserted.

The XIP-3911 and XIP-3901 cards are designed to fit into Grass Valley's Densité3+ frames. The following rear connector panels are available:

- **XIP-3901-3+DRP:** Double rear connector panel for Densité 3+ (DIN connectors)
- **XIP-3901-3+DRP-H:** Double rear connector panel for Densité 3+ (HD BNC connectors)
- **XIP-3911-3+DRP-H:** Double rear connector panel for Densité 3+ (HD BNC connectors)

See [Rear Panel and Connectors](#), on page 50 for details of the signal connections available on a rear panel.

All cards and rear connector panels can be installed with the frame powered on. The card has connectors that plug into a mid-frame motherboard to distribute power and connect to the controller card, as well as a second connector that plugs directly into the rear connector panel for input and output.

The rear connector panel must be installed with the card out of the frame.

- To remove an existing card from the slot, tilt up the swivel handle on the front of the card to lever the connectors apart, then use the handle to pull the card straight out of the slot.

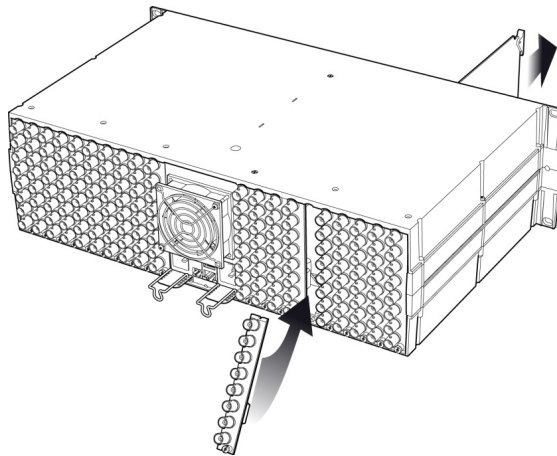

Densité-3 frame – rear panel installation

Step 1: To install the rear connector panel:

- 1 If a card is installed in the slot whose rear panel is being changed, remove it as described above.
- 2 Remove the existing rear connector panel (either blank or belonging to an existing card that is being changed) by releasing the captive screw(s) at the bottom (Densité3+ or Densité-3+FR4) or on the side (Densité-3+FR1) of the panel.
- 3 Position the new rear connector panel and secure it in place with the captive screw(s) at the bottom or on the side.

Step 2: To install the XIP-3911 or XIP-3901 Card:

Once a matching rear connector panel is in place, install the XIP-3911 or XIP-3901 card as follows:

- 1 Open the front panel of the frame.
- 2 Slide the XIP-3911 or XIP-3901 card into the slot and push gently on the handle to seat the connectors.
 - When using a double-slot-width rear panel in a Densité-3+FR1 frame, the card should be inserted into the lower of the two slots.
 - When using a double-slot-width rear panel in a Densité-3+FR4 frame, the card should be inserted into the rightmost of the two slots.

Inserting the card into the wrong slot will not damage the card, but the status LED on the card will flash red to indicate that there is no connection to the rear panel.

- 3 Close the front panel of the frame.

Installation of the Optical Interface (option)

See [Installing the SFP Ethernet Module](#), on page 341.

Rear Panel and Connectors

Images of Rear Panel Connectors

The rear connector panel is shown below. Details of the inputs and outputs are described below. Note that an application may not use all available inputs and outputs.

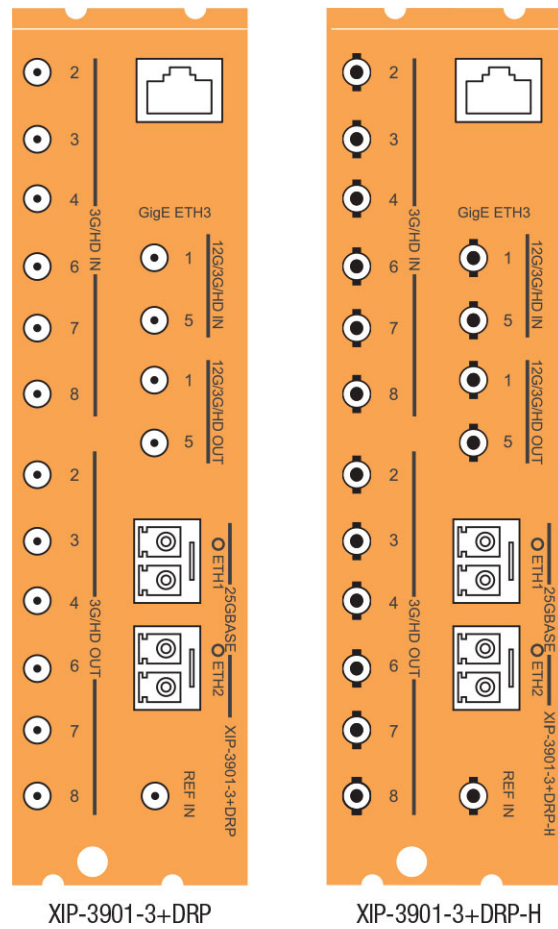

Fig. 3-2: XIP-3901 Rear Panels

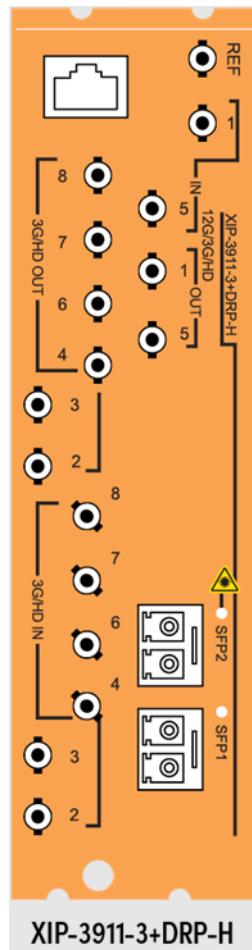

Fig. 3-3: XIP-3911 Rear Panel

Summary of Rear Panel Connections

Connector Nomenclature	Count	XIP-3901-3+DRP Rear Connector Type	XIP-3911-3+DRP-H or XIP-3901-3+DRP-H Rear Connector Type	Used for application	See
REF IN	1	DIN	HD BNC	XIP-3901-UC / DC / FS XIP-3901-UDC-IF	REF IN – External reference , on page 52

Connector Nomenclature	Count	XIP-3901-3+DRP Rear Connector Type	XIP-3911-3+DRP-H or XIP-3901-3+DRP-H Rear Connector Type	Used for application	See
3G/HD IN 2 / 3 / 4 / 6 / 7 / 8	6	DIN	HD BNC	XIP-3901 -DC / -FS XIP-3901-ASI	12G/3G/HD IN – Serial digital 3G/HD Inputs, on page 52 and 12G/3G/HD OUT– Serial digital 12G/3G/HD outputs, on page 54
12G/3G/HD IN 1 / 5	2	DIN	HD BNC	XIP-3901-UC / DC / FS XIP-3901-UDC-IF XIP-3901-ASI	
3G/HD OUT 2 / 3 / 4 / 6 / 7 / 8	6	DIN	HD BNC	XIP-3901-UC / FS XIP-3901-UDC-IF XIP-3901-ASI XIP-3901-JPEG-XS: • 8 HD DEC mode	
12G/3G/HD OUT 1 / 5	2	DIN	HD BNC	XIP-3901-UC / DC / FS XIP-3901-UDC-IF XIP-3901-ASI XIP-3901-JPEG-XS: • 2 UHD/HD DEC mode • 8 HD DEC mode	
25G BASE ETH1 / ETH2	2	SFP+	SFP+	XIP-3901-UDC-IP XIP-3901-GB-IP XIP-3901-UDC-IF XIP-3901-JPEG-XS XIP-3901-ASI	ETH1, ETH2 – 25 GigE on fiber (SFP+), on page 56
GigE ETH3	1	RJ-45	RJ-45	XIP-3901-UC / DC / FS XIP-3901-UDC-IP XIP-3901-GB-IP XIP-3901-UDC-IF XIP-3901-JPEG-XS XIP-3901-ASI	GigE ETH3 – 1 GigE MANAGEMENT Port (RJ-45), on page 60

Details of Rear Panel Connections

REF IN – External reference

Connect an NTSC or PAL reference signal (SMPTE 170M/SMPTE 318M/ITU 624-4 black burst). This is used with the XIP-3901-UC / DC / FS applications only.

12G/3G/HD IN – Serial digital 3G/HD Inputs

Connect serial digital video signals, conforming to SMPTE ST 2081 and ST 2082 for 12G input signals, SMPTE 425M for 3G input signals or SMPTE 292M for HD input signals, to the connectors specified in the tables below.

Connector Nomenclature	XIP-3901-UC Input Signal
12G/3G/HD IN 1	UC1 3G/HD SDI
3G/HD IN 2	Not used
3G/HD IN 3	Not used
3G/HD IN 4	Not used
12G/3G/HD IN 5	UC2 3G/HD SDI
3G/HD IN 6	Not used
3G/HD IN 7	Not used
3G/HD IN 8	Not used

Connector Nomenclature	XIP-3901-DC Input Signal
12G/3G/HD IN 1	DC1 Quad Link 3G - Link 1/12G/3G
3G/HD IN 2	DC1 Quad Link 3G - Link 2
3G/HD IN 3	DC1 Quad Link 3G - Link 3
3G/HD IN 4	DC1 Quad Link 3G - Link 4
12G/3G/HD IN 5	DC2 Quad Link 3G - Link 1/12G/3G
3G/HD IN 6	DC2 Quad Link 3G - Link 2
3G/HD IN 7	DC2 Quad Link 3G - Link 3
3G/HD IN 8	DC2 Quad Link 3G - Link 4

Connector Nomenclature	XIP-3901-FS Input Signal
12G/3G/HD IN 1	FS1 Quad Link 3G - Link 1/12G/3G/HD
3G/HD IN 2	FS1 Quad Link 3G - Link 2
3G/HD IN 3	FS1 Quad Link 3G - Link 3
3G/HD IN 4	FS1 Quad Link 3G - Link 4
12G/3G/HD IN 5	FS2 Quad Link 3G - Link 1/12G/3G/HD
3G/HD IN 6	FS2 Quad Link 3G - Link 2
3G/HD IN 7	FS2 Quad Link 3G - Link 3
3G/HD IN 8	FS2 Quad Link 3G - Link 4

Connector Nomenclature	XIP-3901-UDC-IF Input Signal
12G/3G/HD IN 1	UC1 3G/HD SDI
3G/HD IN 2	Not used
3G/HD IN 3	Not used
3G/HD IN 4	Not used

Connector Nomenclature	XIP-3901-UDC-IF Input Signal
12G/3G/HD IN 5	UC2 3G/HD SDI
3G/HD IN 6	Not used
3G/HD IN 7	Not used
3G/HD IN 8	Not used

Connector Nomenclature	XIP-3901-ASI Input Signal
12G/3G/HD IN 1	DVB-ASI
3G/HD IN 2	DVB-ASI
3G/HD IN 3	DVB-ASI
3G/HD IN 4	DVB-ASI
12G/3G/HD IN 5	DVB-ASI
3G/HD IN 6	DVB-ASI
3G/HD IN 7	DVB-ASI
3G/HD IN 8	DVB-ASI

12G/3G/HD OUT– Serial digital 12G/3G/HD outputs

SDI output signals appear on the rear panel connectors as shown in the table, conforming to SMPTE ST 2081 and ST 2082 for 12G output signals, SMPTE 425M for 3G output signals or SMPTE 292M for HD output signals.

Connector Nomenclature	XIP-3901-UC Output Signal
12G/3G/HD OUT 1	UC1 Quad Link 3G - Link 1/12G/3G
3G/HD OUT 2	UC1 Quad Link 3G - Link 2
3G/HD OUT 3	UC1 Quad Link 3G - Link 3
3G/HD OUT 4	UC1 Quad Link 3G - Link 4
12G/3G/HD OUT 5	UC2 Quad Link 3G - Link 1/12G/3G
3G/HD OUT 6	UC2 Quad Link 3G - Link 2
3G/HD OUT 7	UC2 Quad Link 3G - Link 3
3G/HD OUT 8	UC2 Quad Link 3G - Link 4

Connector Nomenclature	XIP-3901-DC Output Signal
12G/3G/HD OUT 1	DC1 3G/HD SDI
3G/HD OUT 2	DC1 3G/HD SDI
3G/HD OUT 3	DC1 3G/HD SDI
3G/HD OUT 4	DC1 3G/HD SDI

Connector Nomenclature	XIP-3901-DC Output Signal
12G/3G/HD OUT 5	DC2 3G/HD SDI
3G/HD OUT 6	DC2 3G/HD SDI
3G/HD OUT 7	DC2 3G/HD SDI
3G/HD OUT 8	DC2 3G/HD SDI

Connector Nomenclature	XIP-3901-FS Output Signal
12G/3G/HD OUT 1	FS1 Quad Link 3G - Link 1/12G/3G/HD
3G/HD OUT 2	FS1 Quad Link 3G - Link 2
3G/HD OUT 3	FS1 Quad Link 3G - Link 3
3G/HD OUT 4	FS1 Quad Link 3G - Link 4
12G/3G/HD OUT 5	FS2 Quad Link 3G - Link 1/12G/3G/HD
3G/HD OUT 6	FS2 Quad Link 3G - Link 2
3G/HD OUT 7	FS2 Quad Link 3G - Link 3
3G/HD OUT 8	FS2 Quad Link 3G - Link 4

Connector Nomenclature	XIP-3901-UDC-IF Output Signal
12G/3G/HD OUT 1	UDC1 12G/3G/HD SDI
3G/HD OUT 2	UDC1 3G/HD SDI
3G/HD OUT 3	UDC1 3G/HD SDI
3G/HD OUT 4	UDC1 3G/HD SDI
12G/3G/HD OUT 5	UDC2 12G/3G/HD SDI
3G/HD OUT 6	UDC2 3G/HD SDI
3G/HD OUT 7	UDC2 3G/HD SDI
3G/HD OUT 8	UDC2 3G/HD SDI

Connector Nomenclature	XIP-3901-JPEG-XS Output Signal	
	2 UHD/HD DEC 2 UHD/HD ENC	8 HD DEC
12G/3G/HD OUT1	Channel 1	Channel 1
3G/HD OUT2		Channel 2
3G/HD OUT3		Channel 3
3G/HD OUT4		Channel 4
12G/3G/HD OUT5	Channel 2	Channel 5
3G/HD OUT6		Channel 6

Connector Nomenclature	XIP-3901-JPEG-XS Output Signal	
	2 UHD/HD DEC 2 UHD/HD ENC	8 HD DEC
3G/HD OUT7		Channel 7
3G/HD OUT8		Channel 8

Connector Nomenclature	XIP-3901-ASI Output Signal
12G/3G/HD OUT 1	DVB-ASI
3G/HD OUT 2	DVB-ASI
3G/HD OUT 3	DVB-ASI
3G/HD OUT 4	DVB-ASI
12G/3G/HD OUT 5	DVB-ASI
3G/HD OUT 6	DVB-ASI
3G/HD OUT 7	DVB-ASI
3G/HD OUT 8	DVB-ASI

ETH1, ETH2 – 25 GigE on fiber (SFP+)

Transmit and receive video/audio/metadata streams for use with the following applications only:

- XIP-3901-UDC-IP
- XIP-3901-UDC-IF
- XIP-3901-GB-IP
- XIP-3901-JPEG-XS
- XIP-3901-ASI

In addition to video/audio/meta streams, the 25 GigE ports (media ports) support the following protocols:

- PTP
- NMOS IS-04 and IS-05

Note: These connections are not used for SDI applications such as XIP-3901-UC / DC / FS.

To install the SFP+ cartridge, see [Installing the SFP Ethernet Module](#), on page 341.

For the XIP-3901-UDC-IP / XIP-3901-GB-IP, the receiver supports:

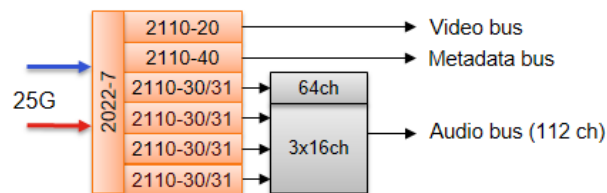

Fig. 3-4: XIP-3901-UDC-IP / -GB-IP Receiver Overview

- One ST 2110-20/21 Wide/Narrow profile stream supporting:
 - 720p, 1080i, 1080p, 2160p 50/59.94 (single-stream) for the XIP-3901-UDC-IP
 - Quad-stream and single-stream 2160p 50/59.94 for the XIP-3901-GB-IP
- One ST 2110-40 stream associated with video
- Up to 4 × ST 2110-30/31 streams
 - level A (from 1 to 8 channels with 1 ms packet times), and
 - Stream 1: level C (1 to 64 channels with 125 us packet times)
 - Stream 2-4: level C (1 to 16 channels with 125 us packet times)
- Full 2022-7 Class A (10msec) & D (150usec) hitless switching protection

For the XIP-3901-JPEG-XS, the receiver supports:

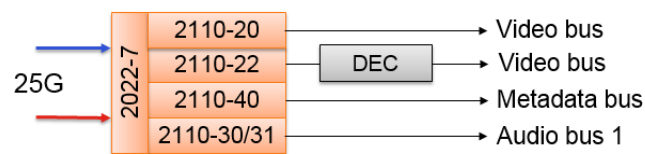

Fig. 3-5: XIP-3901-JPEG-XS Receiver Overview

- One ST 2110-20/21 Wide/Narrow profile stream supporting:
 - 720p, 1080i, 1080p, 2160p 50/59.94 (single-stream)
 - Active on Channel 3 and Channel 4 when the card is in the **Dual UHD/HD DEC & Dual UHD/HD ENC** operation mode
 - Active on Channel 1 to 8 when the card is in the **8 HD ENC** operation mode
- One ST 2110-22 Wide/Narrow profile stream supporting:
 - 720p, 1080i, 1080p, 2160p 50/59.94 (single-stream)
 - Active on Channel 1 and Channel 2 when the card is in the **Dual UHD/HD DEC & Dual UHD/HD ENC** operation mode
 - Active on Channel 1 to 8 when the card is in the **8 HD DEC** operation mode
- One ST 2110-40 stream associated with video
 - Active on Channel 1 and Channel 2 when the card is in the **Dual UHD/HD DEC & Dual UHD/HD ENC** operation mode
 - Active on Channel 1 to 8 when the card is in the **8 HD DEC** operation mode
- One ST 2110-30/31 streams
 - level A (from 1 to 8 channels with 1 ms packet times), and
 - level C (1 to 16 channels with 125 us packet times)
 - Active on Channel 1 and Channel 2 when the card is in the **Dual UHD/HD DEC & Dual UHD/HD ENC** operation mode
 - Active on Channel 1 to 8 when the card is in the **8 HD DEC** operation mode
- Full 2022-7 Class A (10msec) & D (150usec) hitless switching protection

For the XIP-3901-ASI, the receiver supports:

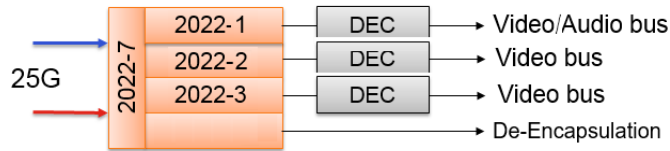

Fig. 3-6: XIP-3901-ASI Receiver Overview

- Full 2022-7 Class B (50ms) hitless switching protection
 - Support for the ST 2022-7 with compliance to class B, maximum of 50ms skew between both media network interface
 - Support for 8 ASI transport output, with a maximum of 213 Mb of payload for each output
 - ST 2022-7 for Seamless Protection Switching of RTP Datagrams
- One ST 2022-1 Wide/Narrow profile stream supporting:
 - ST 2022-1 FEC (Forward Error Correction) for real-time Video/Audio transport over IP Networks
- One ST 2022-2 stream associated with video:
 - ST 2022-2 CBR for Unidirectional Transport of Constant Bit Rate MPEG-2 Transport Streams over IP Network
 - Support for RTP/UDP reception as per ST 2022-2 and ST 2022-3 de-encapsulation
- One ST 2022-3 stream associated with video:
 - ST 2022-3 VBR for Unidirectional Transport of Variable Bit Rate MPEG-2 Transport Streams on IP Networks
 - Support for RTP/UDP reception as per ST 2022-2 and ST 2022-3 de-encapsulation

For the XIP-3901-UDC-IP / XIP-3901-GB-IP, the transmitter supports:

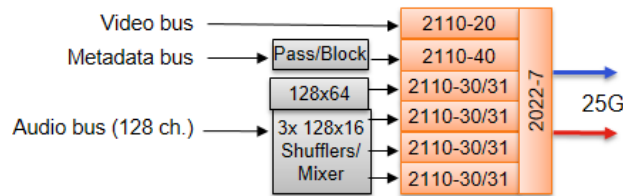

Fig. 3-7: XIP-3901-UDC-IP / -GB-IP Transmitter Overview

- One ST 2110-20 Narrow profile stream supporting:
 - 720p, 1080i, 1080p, 2160p 50/59.94 (single-stream) for the XIP-3901-UDC-IP
 - Quad-stream and single-stream 2160p 50/59.94 for the XIP-3901-GB-IP
- One ST 2110-40 stream associated with video
- Up to 4 × ST 2110-30/31 streams
 - level A (from 1 to 8 channels with 1 ms packet times), and
 - Stream 1: level C (1 to 64 channels with 125 us packet times)
 - Stream 2-4: level C (1 to 16 channels with 125 us packet times)
- Full 2022-7 switching protection

For the XIP-3901-JPEG-XS, the transmitter supports:

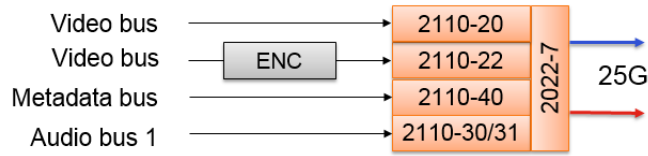

Fig. 3-8: XIP-3901-JPEG-XS Transmitter Overview

- One ST 2110-20 Narrow profile stream supporting:
 - 720p, 1080i, 1080p, 2160p 50/59.94 (single-stream)
 - Active on Channel 1 and Channel 2 when the card is in the **Dual UHD/HD DEC & Dual UHD/HD ENC** operation mode
 - Active on Channel 1 to 8 when the card is in the **8 HD ENC** operation mode
- One ST 2110-22 Narrow profile stream supporting:
 - 720p, 1080i, 1080p, 2160p 50/59.94 (single-stream)
 - Active on Channel 3 and Channel 4 when the card is in the **Dual UHD/HD DEC & Dual UHD/HD ENC** operation mode
 - Active on Channel 1 to 8 when the card is in the **8 HD ENC** operation mode
- One ST 2110-40 stream associated with video
 - Active on Channel 1 and Channel 2 when the card is in the **Dual UHD/HD DEC & Dual UHD/HD ENC** operation mode
 - Active on Channel 1 to 8 when the card is in the **8 HD DEC** operation mode
- One ST 2110-30/31 streams
 - level A (from 1 to 8 channels with 1 ms packet times), and
 - level C (1 to 16 channels with 125 us packet times)
 - Active on Channel 1 and Channel 2 when the card is in the **Dual UHD/HD DEC & Dual UHD/HD ENC** operation mode
 - Active on Channel 1 to 8 when the card is in the **8 HD DEC** operation mode
- Full 2022-7 switching protection

For the XIP-3901-ASI, the transmitter supports:

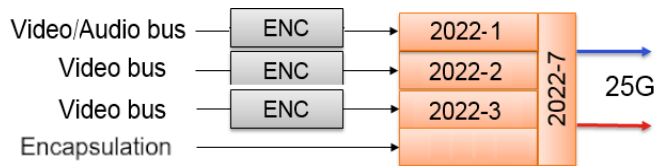

Fig. 3-9: XIP-3901-ASI Transmitter Overview

- One ST 2022-1 Wide/Narrow profile stream supporting:
 - ST 2022-1 FEC (Forward Error Correction) for real-time Video/Audio transport over IP Networks
 - Support for ST 2022-1, Forward Error Correction with independently setting for « **D** » and « **L** » parameters by following the rules described in the standard
 - Selection of multicast or unicast using the IP address range for each stream

- One ST 2022-2 stream associated with video:
 - ST 2022-2 CBR for Unidirectional Transport of Constant Bit Rate MPEG-2 Transport Streams over IP Network
 - Support for RTP/UDP reception as per ST 2022-2 and ST 2022-3 encapsulation
- One ST 2022-3 stream associated with video:
 - ST 2022-3 VBR for Unidirectional Transport of Variable Bit Rate MPEG-2 Transport Streams on IP Networks
 - Support for RTP/UDP reception as per ST 2022-2 and ST 2022-3 encapsulation
- Full 2022-7 switching protection:
 - Support for the ST 2022-7, by replication of each RTP/UDP packet on both media port as per the standard requirement, with primary and secondary IP address settings
 - Support for 8 ASI transport inputs, with a maximum of 213 Mb of payload per stream
 - ST 2022-7 for Seamless Protection Switching of RTP Datagrams

GigE ETH3 – 1 GigE MANAGEMENT Port (RJ-45)

This network port is used:

- For Densité Upgrade Manager (DUM) upgrades.
- To upload Custom LUTs (for the XIP-3901-UC / DC / FS and XIP-3901-UDC-IP applications only).
- For NMOS IS-04 and IS-05 (for the XIP-3901-UDC-IP, XIP-3901-GB-IP, XIP-3901-JPEG-XS, and XIP-3901-ASI applications only).

This connection is not necessary when the XIP-3911 or XIP-3901 is used with Densité frames that are equipped with Densité 3+FR4 STD or Densité 3+ FR4 ADV frame controllers that are connected to the management IP network.

User Interface

Control options

The XIP-3911 or XIP-3901 card's applications can be controlled in the following ways:

Application	See
XIP-3901-UC, XIP-3901-DC, or XIP-3901-FS	<ul style="list-style-type: none">• The local control panel and its buttons can be used to move through a menu of status reports. See Local Control Using the Densité Frame Control Panel, on page 67.• Grass Valley's iControl system must be used to access the card's operating parameters remotely using a convenient graphical user interface (GUI). See Card Upgrade with iControl Solo, on page 71.
XIP-3901-UDC-IP	
XIP-3901-UDC-IF	
XIP-3901-GB-IP	

Application	See
XIP-3901-JPEG XS	<ul style="list-style-type: none">• The local control panel and its buttons can be used to move through a menu of status reports. See Local Control Using the Densité Frame Control Panel, on page 67.• A web browser must be used to access the card's operating parameters remotely using a convenient graphical user interface (GUI). See Configuring the XIP 3901-JPEG-XS v1.0 Application with its Web Interface, on page 275.
XIP-3901-ASI	<ul style="list-style-type: none">• The local control panel and its buttons can be used to move through a menu of status reports. See Local Control Using the Densité Frame Control Panel, on page 67.• A web browser must be used to access the card's operating parameters remotely using a convenient graphical user interface (GUI). See Configuring the XIP 3901-ASI v1.0 Application with its Web Interface, on page 307.

4 Connections and Cabling

XIP-3901-UC, XIP-3901-DC, or XIP-3901-FS	XIP-3901-UDC-IP	XIP-3901-UDC-IF	XIP-3901-GB-IP	XIP-3901-JPEG XS, or XIP-3901-ASI
•	•	•	•	•

Cabling Diagrams XIP-3911 or XIP-3901

The following figures show the typical connections for an XIP-3911 or XIP-3901.

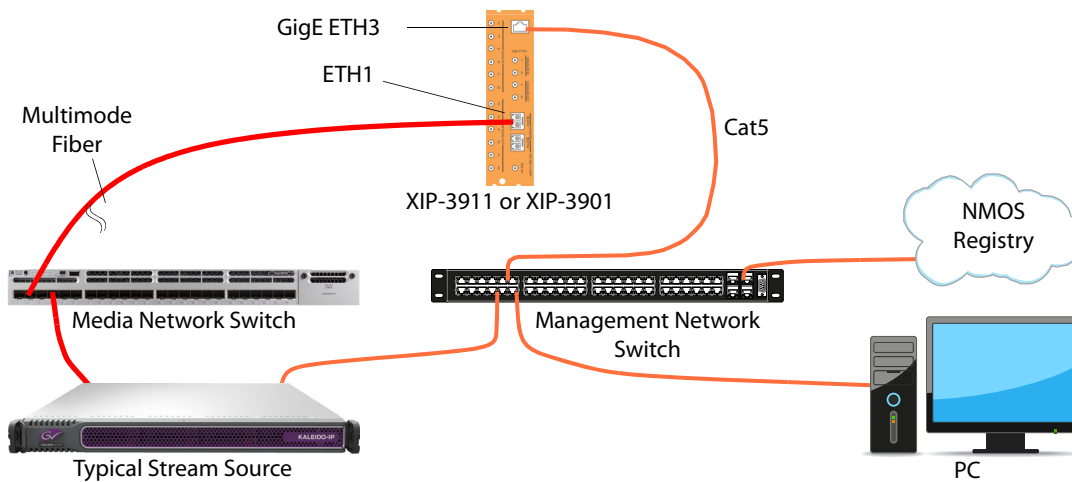

Fig. 4-1: Typical XIP-3911 or XIP-3901 Network Cabling when the card is installed in a Densité 3+FR1 or Densité 3+FR4 frame with a CPU-ETH3 Basic controller, then the card's ETH3 port must be used to connect to the Management IP network.

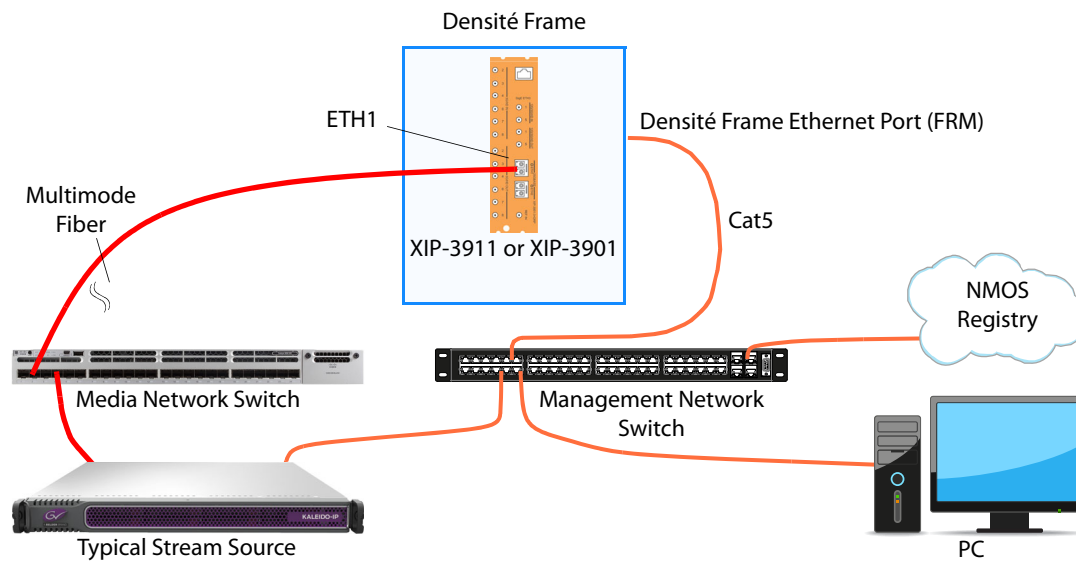

Fig. 4-2: Typical XIP-3911 or XIP-3901 Network Cabling when the XIP-3911 or XIP-3901 is used with Densité frames that are equipped with Densité 3+FR4 STD or Densité 3+ FR4 ADV frame controller that is connected to the Management IP network.

Cabling to Support SMPTE ST 2022-7

The XIP-3911 or XIP-3901 supports network redundancy, for use with any SMPTE ST 2022-7 compatible equipment.

To make streaming more reliable over an IP network, the implementation of SMPTE ST 2022-7 seamless protection switching depends on stream redundancy. This protection scheme transmits two identical packet streams over physically separate network routes (shown as Media Red LAN and Media Blue LAN in the figure below), so that if packets from one route are lost, the data can be reconstructed using packets from the second stream. This process is seamless because switching between the streams is instantaneous and does not impact content.

PREREQUISITE:

- At least two DCNM-compliant switches must be used for this application. Contact Grass Valley for more information about switch compatibility. See [Grass Valley Technical Support](#), on page 354.

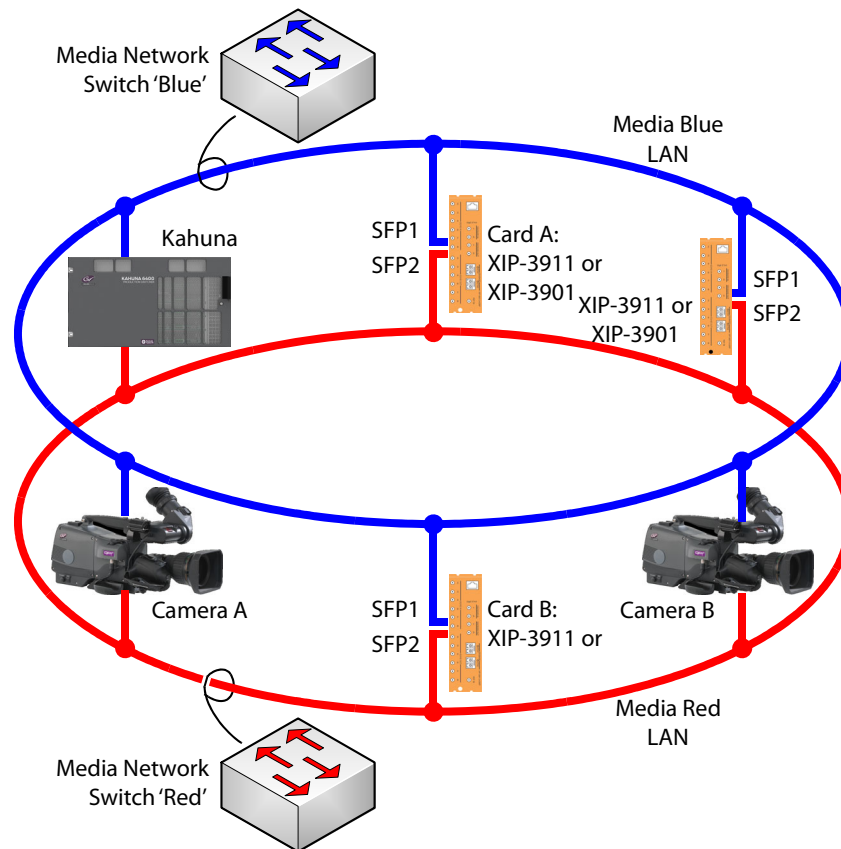
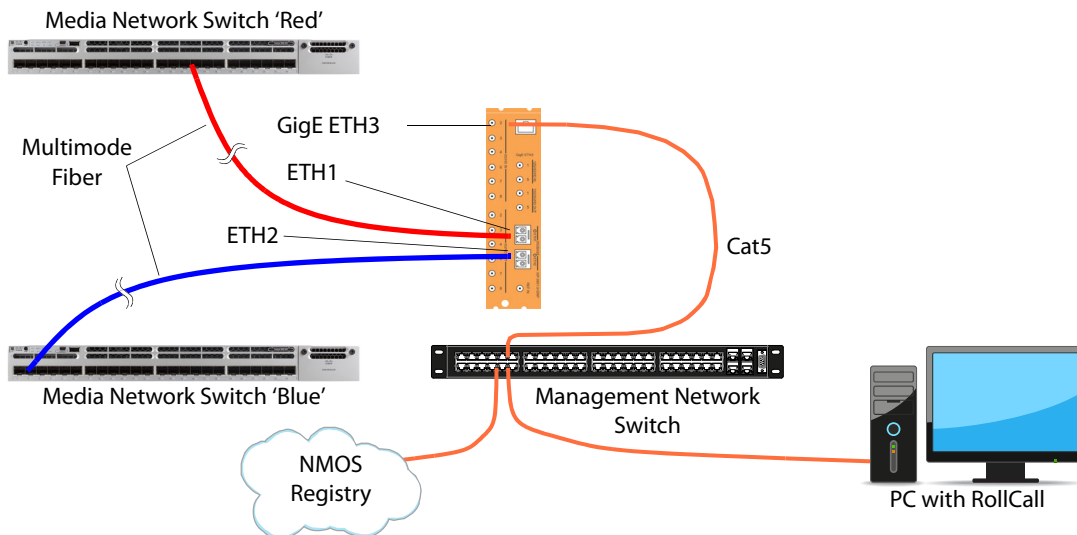
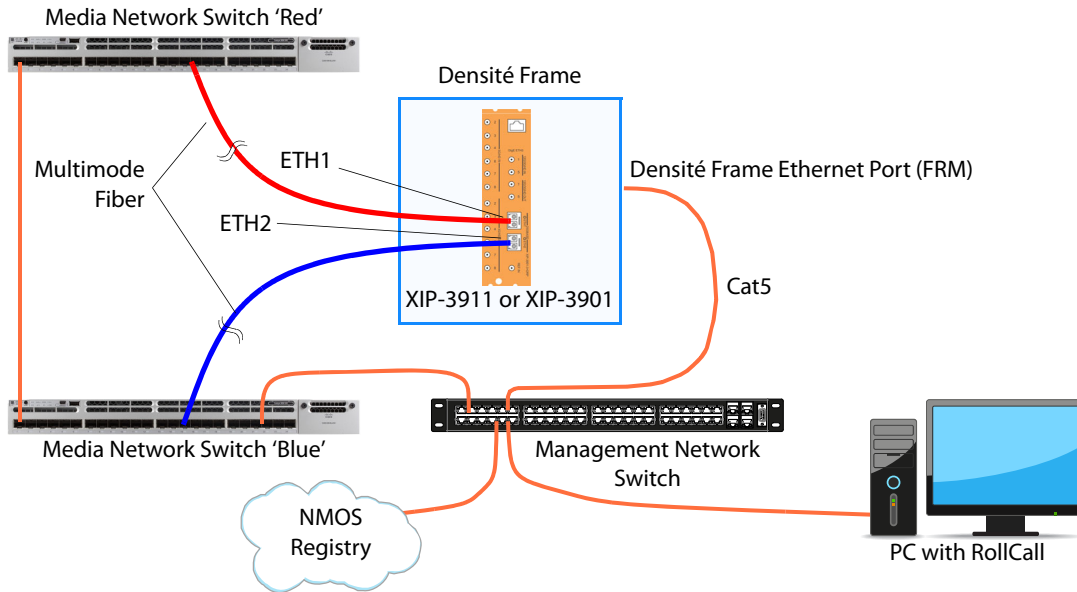

Fig. 4-3: Typical SMPTE ST 2022-7 XIP-3911 or XIP-3901 Network Overview

The SMPTE ST 2022-7 cabling connections are shown in greater detail below for XIP-3911 or XIP-3901.



The SMPTE ST 2022-7 cabling connections are shown in greater detail below for XIP-3911 or XIP-3901 when installed in a Densité frame that is equipped with Densité 3+FR4 STD or Densité 3+ FR4 ADV frame controllers that is connected to the management IP network.





5

Local Control Using the Densité Frame Control Panel

XIP-3901-UC, XIP-3901-DC, or XIP-3901-FS	XIP-3901-UDC-IP	XIP-3901-UDC-IF	XIP-3901-GB-IP	XIP-3901-JPEG XS, or XIP-3901-ASI
●	●	●	●	●

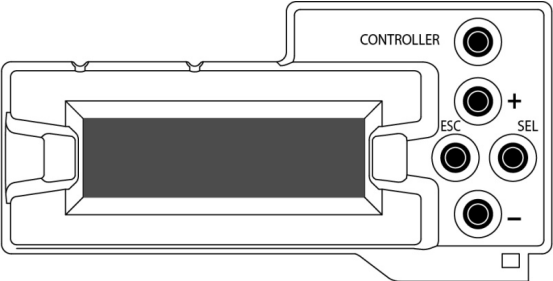
There are two types of local control panels:

Panel type	Frame models	Appearance
Physical	Densité-3+FR1	
Touch-screen	Densité-3+FR4, GV Node	

To assign the local control panel to the XIP-3911 or XIP-3901:

- Physical panel: Open the front door of the frame to access the panel. Push the [SELECT] button on the front of the card (see [Front Card-edge Interface](#), on page 41).
- Touch-screen panel: Use the opening in the frame door to access the panel. On the home screen, touch the icon that corresponds to the card.

The status LED on the XIP-3911 or XIP-3901 will flash yellow, and the touch-screen status will be yellow for the XIP-3911 and XIP-3901.

The panel displays two lines of 16 characters and the following four buttons for navigating the menu:

Button	Description
[+] [-]	Navigate menus and modify values.

Button	Description
[SEL]	Accesses the next menu level. When a parameter value is shown, push this button once to modify the value using the [+] and [-] buttons; push it again to confirm the new value.
[ESC]	<p>Cancels parameter value changes that have not been confirmed and reverts the parameter to its former value.</p> <p>Returns to the previous menu. In the main menu, [ESC] does <i>not</i> exit the menu system. To exit, push the [SELECT] button on the card being controlled.</p>

If no controls are operated for 30 seconds, the controller reverts to its normal standby status, and the selected card's status reverts to its normal operating mode.

The complete menu structure is shown in [Local Menu](#), on page 339.

Setting the Card's IP Addresses

Only make changes to the Ethernet settings during off hours as any settings change will take the card offline for up to 30 seconds.

Push the SELECT button on the XIP+3911 & XIP+3901 card edge (see [Front Card-edge Interface](#), on page 41) to assign the local control panel to operate the XIP+3911 & XIP+3901.

- The STATUS LED on the XIP+3911 & XIP+3901 card edge flashes yellow.

Use the control panel buttons to navigate through the menu. The menu allows you to view and set the card's current:

- **MANAGEMENT** Ethernet port IP address.
- **SFP1** and **SFP2** Ethernet port IP addresses that you use for media streams.

See also the **Network**, Interface tab.

To Configure	See also the Network > Interface tab
XIP-3901-UC, XIP-3901-DC, or XIP-3901-FS	Network Panel , on page 119
XIP-3901-UDC-IP	Network Panel , on page 125
XIP-3901-UDC-IF	Network Panel , on page 182
XIP-3901-GB-IP	Network Panel , on page 239
XIP-3901-JPEG-XS, or XIP-3901-ASI	Interfaces Panel , on page 291

The Ethernet port configuration parameters are:

- The Ethernet port's current operating mode: DHCP or DISABLE.
- The Ethernet port's current IP Address: when mode is set to DISABLE, set the card's IP address.
- The Ethernet port's current subnet Mask: when mode is set to DISABLE, set the subnet mask for your network.

- The Ethernet port's current default Gateway: When mode is set to DISABLE, set the network switch's IP address.

The XIP+3911 & XIP+3901 will reboot once you have changed a network parameter when:

- Densité local control is removed from the card or,
- You navigate back to the top level menu. You can change all network parameters in one shot (without the unit rebooting for every parameter change) by staying at a menu level lower than the top level menu (stay within the NETWORK SETTINGS menu level or lower) when changing the network settings.

A reboot takes approximately 30 seconds.

Getting Started with iControl



XIP-3901-UC, XIP-3901-DC, or XIP-3901-FS	XIP-3901-UDC-IP	XIP-3901-UDC-IF	XIP-3901-GB-IP	XIP-3901-JPEG XS, or XIP-3901-ASI
•	•	•	•	

Card Upgrade with iControl Solo

The XIP-3911 or XIP-3901 card upgrade can be made through iControl Solo or through the iControl Appserver.

Starting iControl Solo

To setup the XIP-3911 or XIP-3901 card, you must have installed on your PC iControl Solo, version 7.51 or higher.

To verify the version of iControl Solo installed on your PC, go to the **Help** menu and select **About**, as shown below:

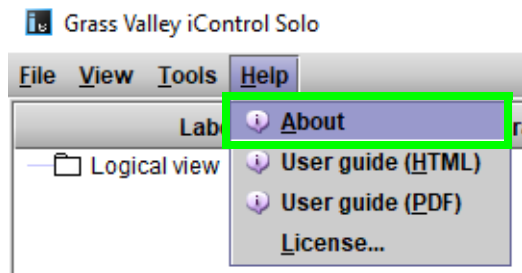

iControl Solo can be downloaded from the Grass Valley website. See [iControl Solos Software](#).

Downloading new XIP applications

XIP-3901 applications can be downloaded from the Grass Valley support site, under **Downloads for Broadcast Products** and look for **XIP-3901 Agile Modular SDI/IP Processing Platform for Densité 3+** to download latest applications.

This is a .ZIP file. Do not unzip the file for the following procedures.

Installing new applications on the XIP-3911 or XIP-3901

To install a new application on an XIP-3911 or XIP-3901, proceed as follows:

- 1 In iControl Solo or in iControl Navigator, go in the **Tools** menu and select **Densité Upgrade Manager**, as shown below:

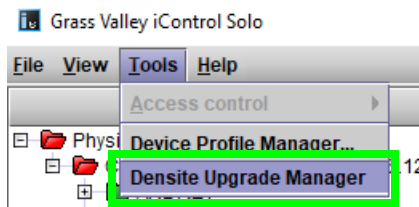

This will start the Densité Upgrade Manager. It may take a few minutes for the frames and cards to populate the window.

In the **Physical View** Tab (1), you will see a list of Densité frames (2), and for each Densité frame is a list of cards installed in the frame's slots (3). You need to expand the tree to see the information, as shown below:

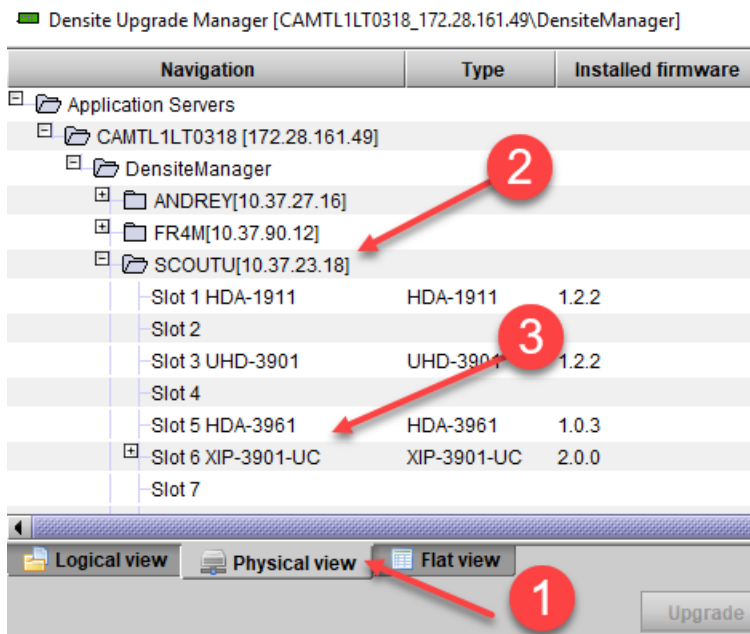

- 2 Click **Upload files** found at the bottom of the Densité upgrade manager, and in the file browser, select one or more XIP application ZIP files, as shown below. Use <Ctrl> + click to select more than one file.

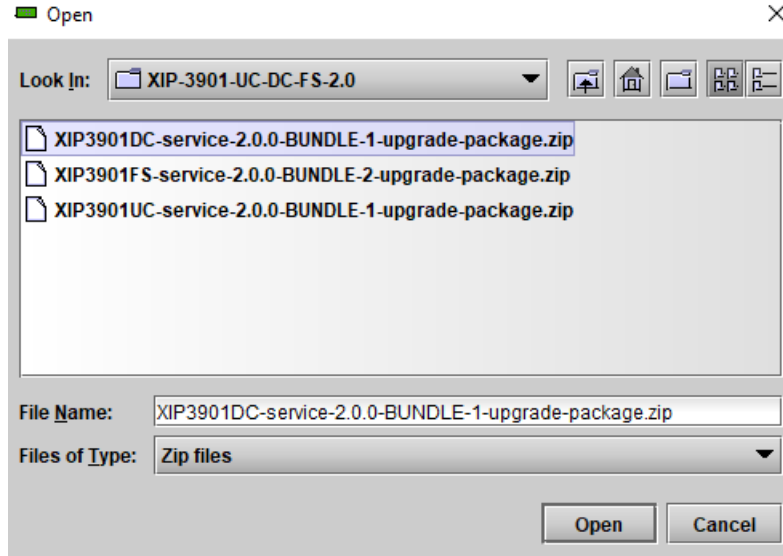

- 3 Click **Open**.
- 4 Click **Upload** in the Progress dialog:

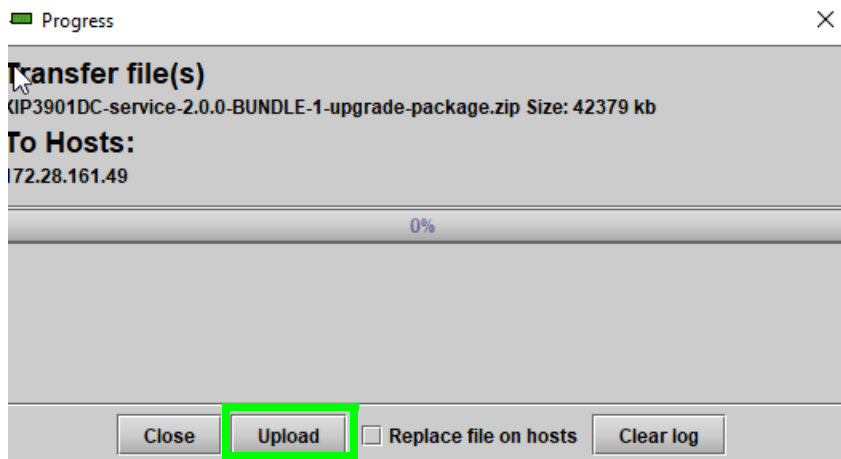

- 5 Once the upload of the application(s) has completed, click **Close**.
- 6 Once complete, click **Clear** at the bottom of the Densité Upgrade Manager window.
- 7 Select the application you want to now use on your XIP-3911 or XIP-3901 card. Click the **Available package** pulldown for the corresponding XIP-3911 or XIP-3901 card you want to install/update and select the appropriate bundle for it from the list.

Getting Started with iControl

Opening the XIP-3911 or XIP-3901 Panel

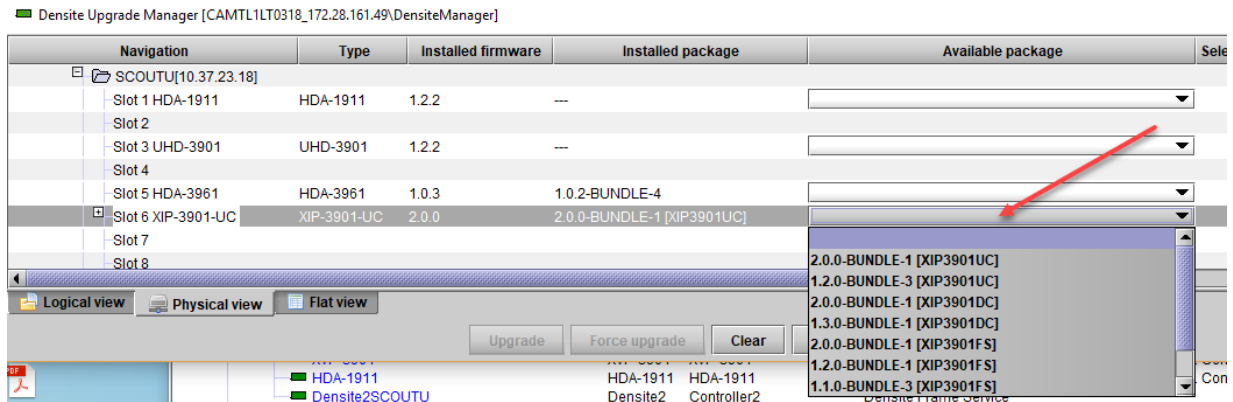

8 Click **Upgrade** to launch the card's upgrade process by uploading the firmware into the XIP-3911 or XIP-3901 card and installing the corresponding application.

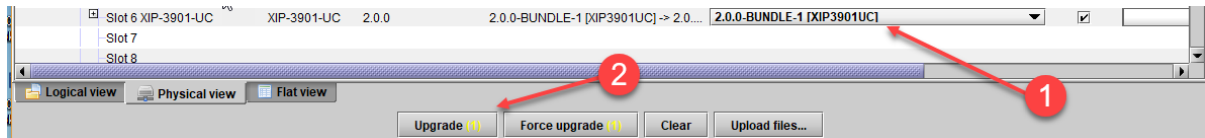

The installation progress bar updates, as shown below:



And then it completes.



The XIP-3911 or XIP-3901 card then will disappear for 30 seconds as it will reboot after the upgrade and then it will show the XIP-3911 or XIP-3901 card with the right firmware and installed package, as shown below.

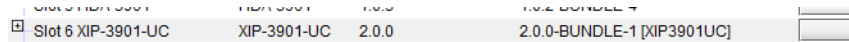

You can use the **Available package** pull-down to activate any other application, at any time. The last installed application will be the current one running on the XIP-3911 or XIP-3901.

Opening the XIP-3911 or XIP-3901 Panel

Close the Densité Upgrade Manager and then launch the XIP-3901 application from iControl Solo by double clicking on the XIP-3901-UC application to launch the iControl panel for the card. As shown below, this example shows that the XIP-3901-UC was the last application installed on the card:

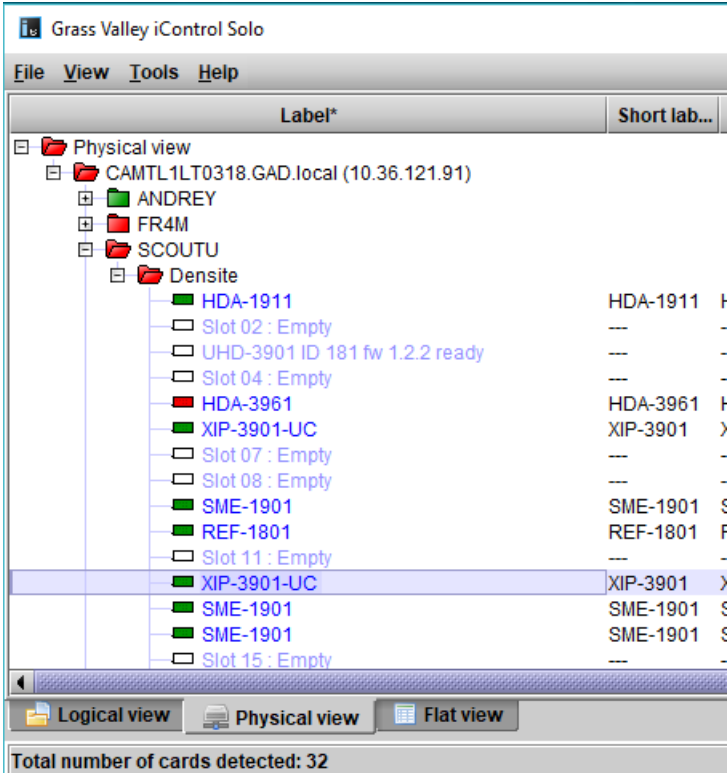

The iControl panel for the card then shown.

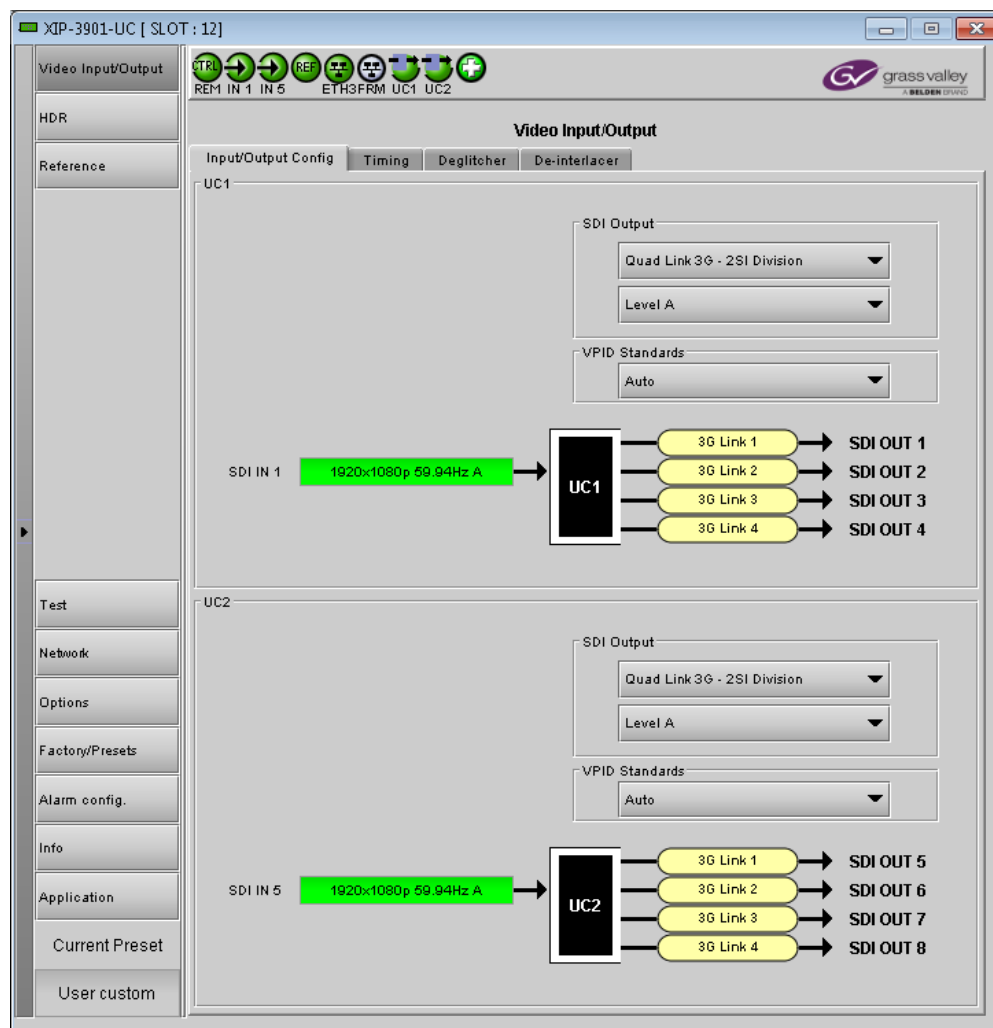

You can also change the current application in the **Application** panel. See [Application Panel](#), on page 261.

iControl System User Interface

XIP-3901-UC, XIP-3901-DC, or XIP-3901-FS	XIP-3901-UDC-IP	XIP-3901-UDC-IF	XIP-3901-GB-IP	XIP-3901-JPEG XS, or XIP-3901-ASI
●	●	●	●	

The XIP-3901 applications can be remotely controlled using Grass Valley's iControl system. This manual describes the control panels associated with the XIP-3901 applications and their use. Please consult the iControl User's Guide for information about setting up and operating iControl.

In iControl Navigator or iControl Websites, double-click on the XIP-3901-UC, XIP-3901-DC, XIP-3901-FS, XIP-3901-UDC-IP or XIP-3901-GB-IP icon to open the control panel (for XIP-3901-UC v1.0 only, the icon shows XIP-3901).

The basic configuration window structure is shown in [XIP-3901 iControl Graphic Interface \(Shown on XIP-3901-UC\)](#), on page 77. Although the example displayed is from the XIP-3901-UC, the XIP-3901-DC, XIP-3901-FS, XIP-3901-UDC-IP, and XIP-3901-GB-IP interfaces follow the same structure. The window title bar shows the card type and the slot number where the card is installed in its Densité frame.

There are four main sections in the window:

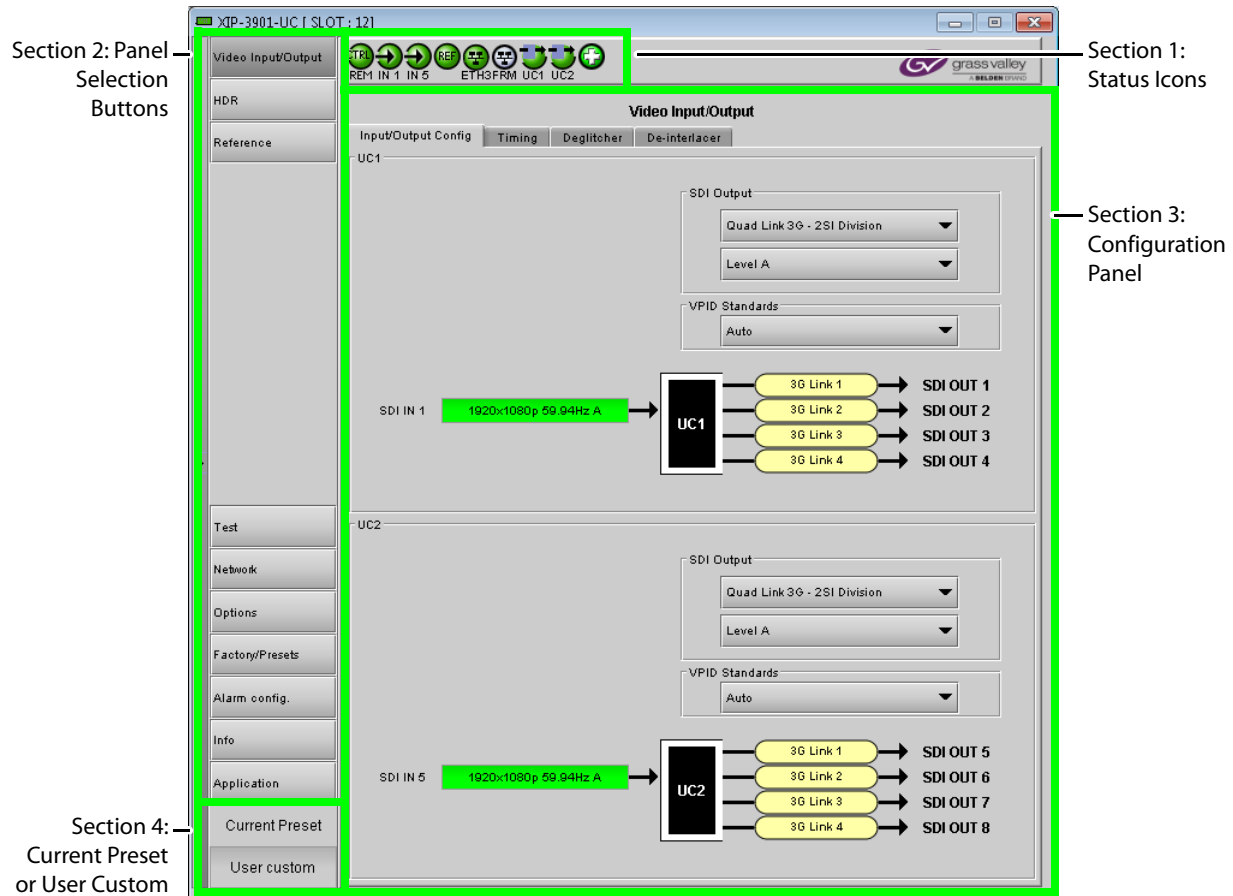

Figure 6-1: XIP-3901 iControl Graphic Interface (Shown on XIP-3901-UC)

Section 1: Status Icons

The top section displays icons that report different statuses, such as the card communication status, input status, health status, and card operating mode. Mousing over an icon will display a status message with additional information.



Figure 6-2: XIP-3901-UC Status Icons



Figure 6-3: XIP-3901-DC Status Icons



Figure 6-4: XIP-3901-FS Status Icons



Figure 6-5: XIP-3901-UDC-IP Status Icons



Figure 6-6: XIP-3901-UDC-IF Status Icons



Figure 6-7: XIP-3901-GB-IP Status Icons

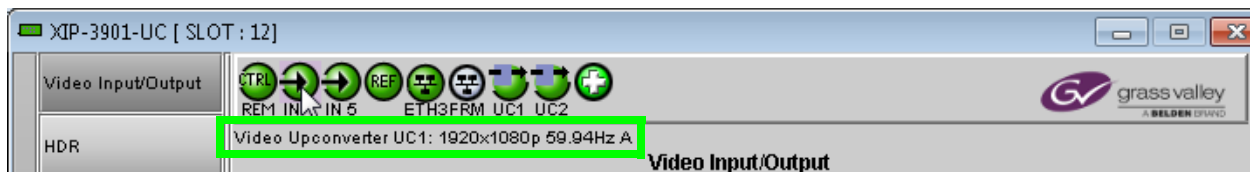



























Figure 6-8: XIP-3901 Status Message (mouse over a status icon, shown on XIP-3901-UC)

The table below describes the various iControl status icons that can appear. If more than one interpretation is possible, read the error message in the iControl window to see which applies.

Status Icon	Description
Manual Card Configuration	
 CTRL REM (green)	Remote card control is activated. The iControl interface can be used to operate the card.
 CTRL LOCAL (yellow)	Local card control is activated. The card is being controlled using the Densité frame control panel, as described in Local Control Using the Densité Frame Control Panel , on page 67. Any changes made using the iControl interface will have no effect on the card.
Media Network (UDC-IP, UDC-IF, and GB-IP only)	
 IP (green)	No IP status error.

Status Icon	Description
 IP (red)	At least one IP status is in error. See: <ul style="list-style-type: none"> • Receiver Stream statuses, see: <ul style="list-style-type: none"> • Config Tab, on page 135 • Config Tab, on page 189 • Config Tab, on page 240 • Receiver Media statuses, see: <ul style="list-style-type: none"> • Timing Tab, on page 137 • Timing Tab, on page 193 • Timing Tab, on page 243 • Receiver Media statuses, see: <ul style="list-style-type: none"> • Redundancy Tab, on page 138 • Redundancy Tab, on page 206 • Redundancy Tab, on page 244. • Sender Stream statuses, see: <ul style="list-style-type: none"> • UDC1 Tabs, on page 140, UDC2 Tab, on page 143 • UDCn Tabs, on page 212 • GB1 / GB2 Tabs, on page 245 • NMOS IS-04 Registration status, see: <ul style="list-style-type: none"> • NMOS Panel, on page 133 • NMOS Panel, on page 185 • NMOS Panel, on page 239
UDC1 / UDC2 Input Status (-UDCIP only)	
 UDC1 (green)	Video is present and valid. The video format is indicated when there are no errors.
 UDC1 (red)	Video not present; or Video invalid; or Video unsupported; or Rate mismatch.
 UDC1 (grey)	Receiver Disabled.
GB1 / GB2 Input Status (-GBIP only)	
 GB1 (green)	Video is present and valid. The receiver operation mode is indicated.
 GB1 (red)	Video not present; or Video invalid; or Video unsupported.

Status Icon	Description
 (grey)	Receiver Disabled.
SDI IN Status (UC)	
 (green)	SDI is present and valid. The video format is indicated when there are no errors.
 (red)	SDI not present; or SDI invalid; or SDI unsupported; or Reference mismatch.
SDI IN Status (DC and FS only)	
 (green)	All SDI inputs are present and valid. At least one SDI input is reporting an error. See the diagram in the Input/Output Config tab to diagnose the issue.
 (red)	At least one SDI input is reporting an error. See the diagram in the Input/Output Config tab to diagnose the issue.
Reference Status (UDC-IF, UC, DC, and FS only)	
 (green)	References on both processing channels are locked.
 (red)	Reference on at least one processing channel is not locked. See Reference Panel , on page 116 or Reference Panel , on page 186 for more details on the problem(s).
PTP Status (UDC-IP, UDC-IF, and GB-IP only)	
 (green)	The card is locked to the network's PTP.
 (red)	The card is not locked to the network's PTP. For more details on the problem(s), See PTP Panel , on page 131, PTP Panel , on page 183, or PTP Panel , on page 239.
Network Status (ETH1/ETH2/ETH3/FRM)	
 (green)	Network linkup and active.
 (red)	No network link (port down).
 (gray)	Network port is disabled.

Status Icon	Description
 (yellow)	Network connections in progress.
Operating Mode	
 (green)	Operating mode: Process
 (red)	Operating mode: Color Bars & Tone
Health Monitoring	
 (green)	Hardware OK.
 (red)	Hardware failure detected. If this icon is flashing red, call Technical Support.

If there is an error, the error status message will appear in the message area.

- If there are multiple errors, the error messages cycle so that each message can be seen.
- The icon for the status or error message being shown will be highlighted in mauve.

Section 2: Panel Selection Buttons

Click a button in the left portion of the window to select a configuration panel. The button is highlighted when it is selected.

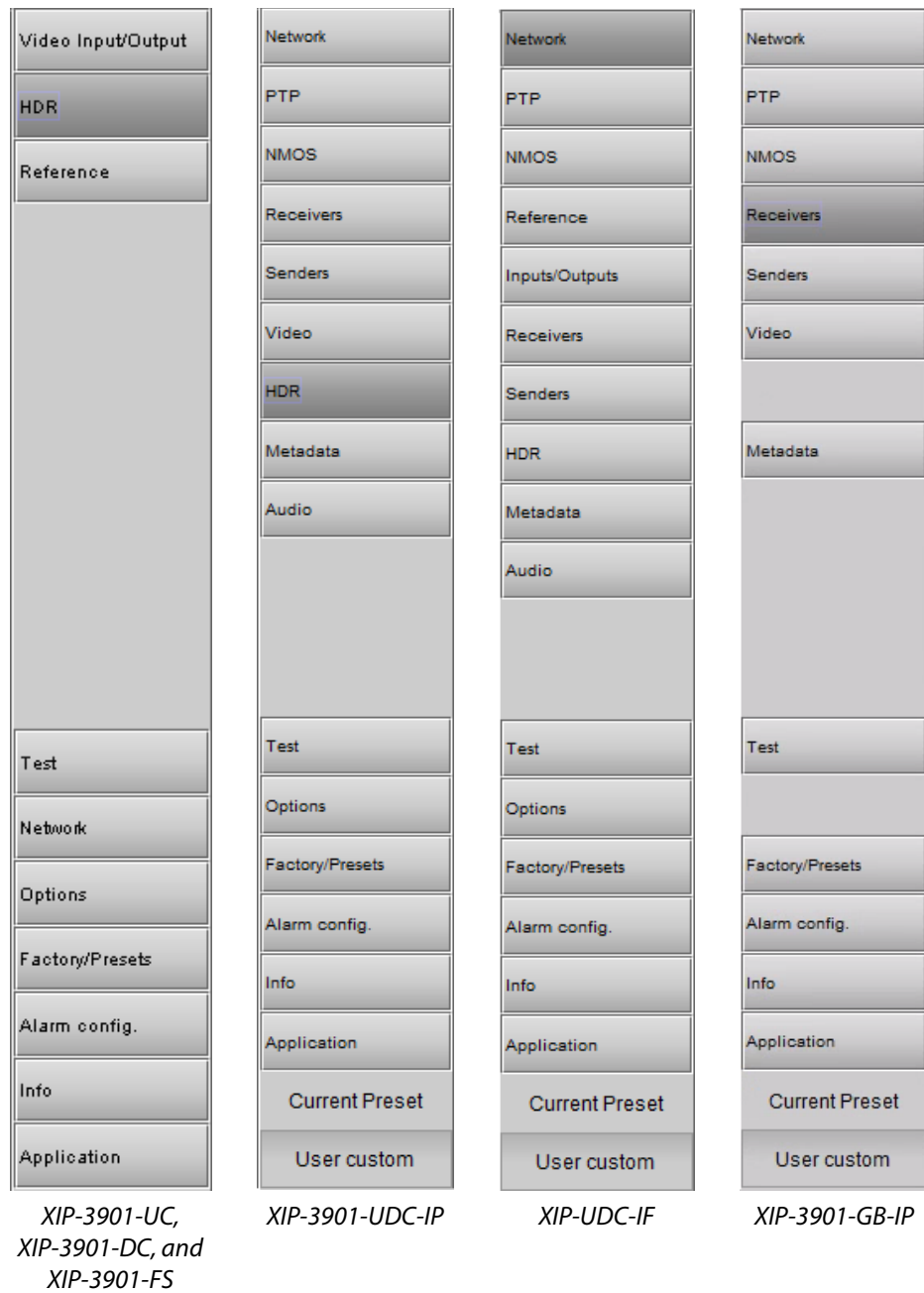

Figure 6-9: Buttons for Each Individual Panel

Section 3: Configuration Panel

This main section displays the panel selected in Section 2. It may contain multiple tabs to access any appropriate sub-panel.

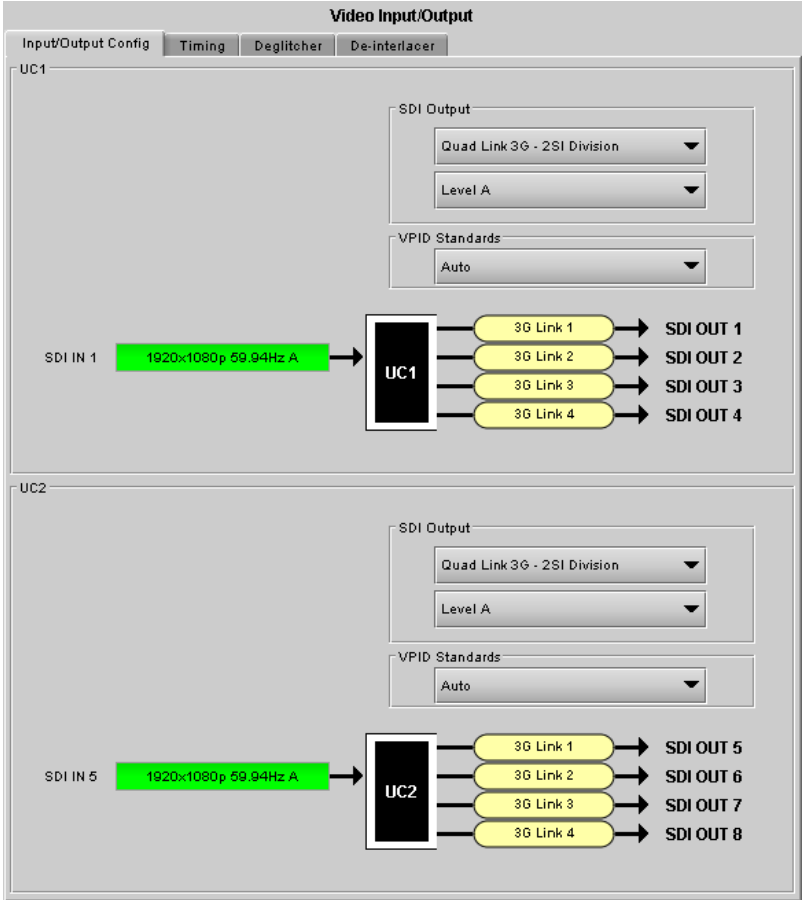

Figure 6-10: Panel Display (Shown on XIP-3901-UC)

Section 4: Current Preset or User Custom

The lower left corner of the window identifies the preset currently in use, "User custom" if none is applicable, or "Factory default" when the card is currently using its factory-default settings.

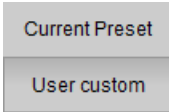

Figure 6-11: Current Preset or User Custom

XIP-3901 Card Application Configuration

To Configure	Configuration Interface		See
	iControl	Web Browser	
XIP-3901-UC, XIP-3901-DC, or XIP-3901-FS	●		Configuring the XIP-3901-UC / -DC / -FS Applications with iControl , on page 85
XIP-3901-UDC-IP	●		Configuring the XIP-3901-UDC-IP v1.2 Application with iControl , on page 125
XIP-3901-UDC-IF	●		Configuring the XIP 3901-UDC-IF v4.0 Application with iControl , on page 179
XIP-3901-GB-IP	●		Configuring the XIP-3901-GB-IP Application with iControl , on page 239
XIP-3901-JPEG-XS		●	Configuring the XIP 3901-JPEG-XS v1.0 Application with its Web Interface , on page 275
XIP-3901-ASI		●	Configuring the XIP 3901-ASI v1.0 Application with its Web Interface , on page 307



Configuring the XIP-3901-UC / -DC / -FS Applications with iControl

XIP-3901-UC, XIP-3901-DC, or XIP-3901-FS	XIP-3901-UDC-IP	XIP-3901-UDC-IF	XIP-3901-GB-IP	XIP-3901-JPEG XS	XIP-3901-ASI
●					

This section describes the control panels associated with the XIP-3901-UC / DC / FS applications and their use.

Application	See
XIP-3901-UC	Video Input/Output Panel (XIP-3901-UC) , on page 85
XIP-3901-DC	Video Input/Output Panel (XIP-3901-DC) , on page 92
XIP-3901-FS	Video Input/Output Panel (XIP-3901-FS) , on page 98

Video Input/Output Panel (XIP-3901-UC)

Input/Output Config Tab

This panel allows you to configure the settings for the two upconverters. Each can be configured independently.

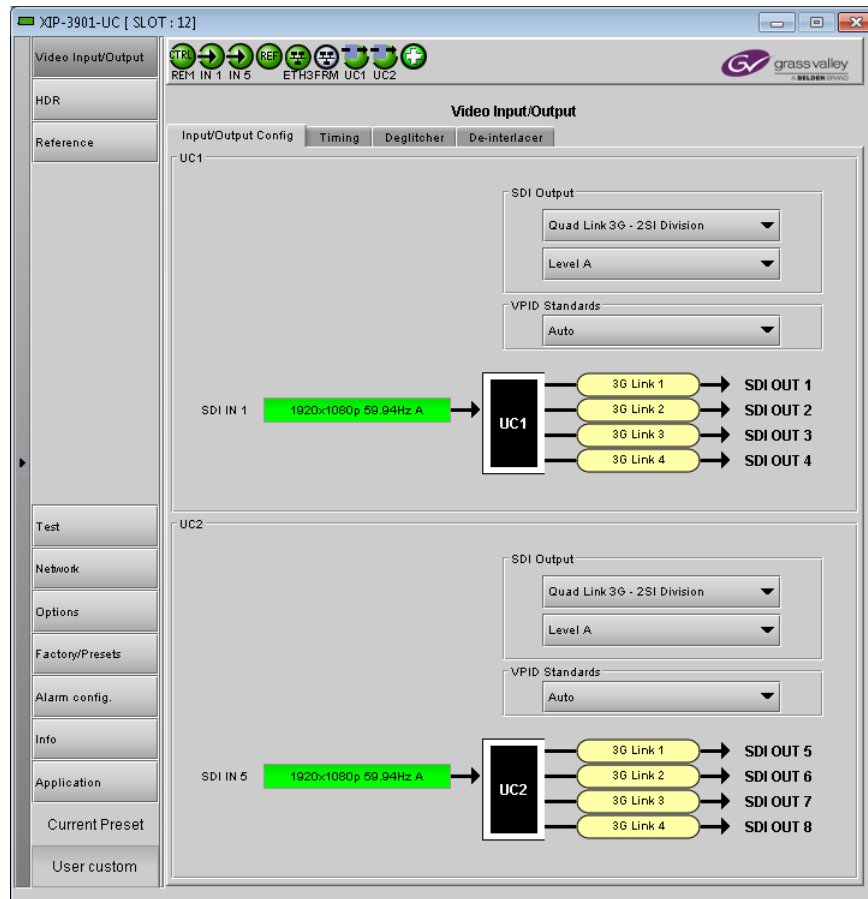

Figure 7-1: Video I/O Config

Use the pull-down menus to configure these parameters:

Parameter	Settings	Note	
SDI Output	Transport & 2160-Line Data Mapping (on Quad Link 3G)	Quad Link 3G – 2SI Division (default) Quad Link 3G – Square Division 12G 3G	1
	3G Mapping	Level A (default) Level B Dual-Link	3
Video Payload ID (Transfer Characteristic, Colorimetry, and Bit depth) Standards	Auto (default) 3 Gbps Legacy (SMPTE 4251)	2	

Note 1: For each processing channel, you must select the format of the SDI output transport using the SDI Output pull-down menu. For the Quad Link 3G SDI Transport setting, you must also select which 2160-Line Data Mapping to use (Square Division or 2SI Division). The choice will depend on the format used by the destination equipment.

- **Quad Link 3G – Square Division:** The 4K image is split into four full-resolution quadrants, each sent on a single 3G link.

- **Quad Link 3G – 2SI Division:** The 4K image is sub-sampled into four full-frame images, each at half the vertical and horizontal resolution.
- **12G:** The 4K image is sent on a single 12G link.
- **3G:** The image is sent on a single 3G Link.

Note 2: Usually, 2-Sample Interleave outputs have a different Video Payload ID (Transfer Characteristic, Colorimetry, and Bit depth) on each link, per SMPTE 4255. Some downstream equipment may not support this standard, so the use of SMPTE 4251 Video Payload IDs (Transfer Characteristic, Colorimetry, and Bit depth) can be forced by selecting 3Gbps legacy in the Video Payload ID (Transfer Characteristic, Colorimetry, and Bit depth) Standards pulldown menu. Video Payload ID (Transfer Characteristic, Colorimetry, and Bit depth) Standards settings are ignored when the SDI Output is set to 3G or 12G.

Video Payload ID (Transfer Characteristic, Colorimetry, and Bit depth) Standards	Quad Link 3G	
	Square Division	2SI Division
Auto	SMPTE 4251	SMPTE 4255
3Gbps legacy	SMPTE 4251	SMPTE 4251

Note 3: The XIP-3901-UC supports two of the mappings of video into the serial digital interface defined by SMPTE 424M. 3G Mapping settings are ignored when the SDI Output is set to 12G.

- The Level A format is the direct mapping of uncompressed 1080p (up to 60 fps) video into a serial digital interface at the nominal 3 Gbps.
- The Level BDL (DualLink) format is the mapping of DualLink HDSDI/SMPTE 372M (for example, 1080p up to 60 fps) in a single serial digital interface at the nominal 3 Gbps.

A diagram of the upconversion process is displayed underneath the settings for each processing channel. Each link will be either green (no error) or red (error).

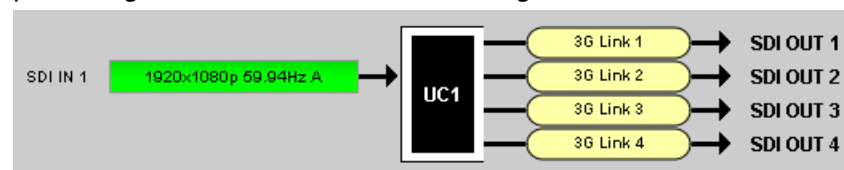

Figure 7-2: Upconversion Diagram

Timing Tab

For each processing channel, you can adjust the timing relative to the reference. Use the slider or type a value into the data box on the right of the slider.

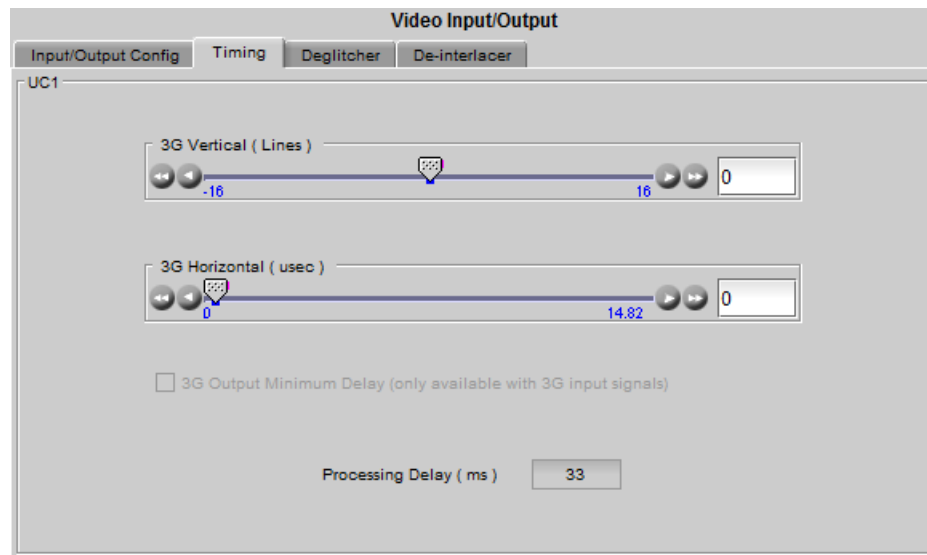

Figure 7-3: Video I/O Timing

The sliders can be adjusted as follows:

Adjustment	Range
Vertical (lines)	16 to +16
Horizontal (msec)	Up to 1 line: 0 to 14.82msec (59 Hz) 0 to 17.77msec (50 Hz)

For a 3G SDI Output, the 3G Output Minimum Delay setting can be enabled. In this case, the reference source will be forced to Input for this channel and your settings for the reference source will be ignored (see [Reference Panel](#), on page 116 for more information). The 3G Mapping settings will also be ignored. If Level A format is received, the card will output Level A. If Level B DualLink format is received, the card will output Level B DualLink. The following features are also disabled:

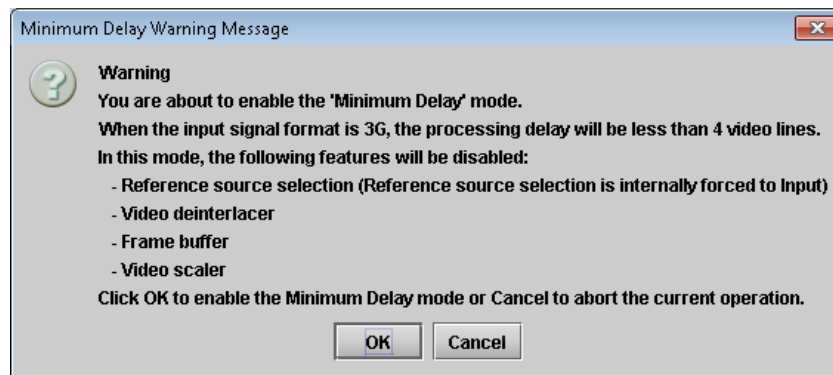

Figure 7-4: Disabled Features

This section also displays the Processing Delay in milliseconds (ms) for each channel so you can manage the processing delay on your system.

Min. Delay	Ref	SDI Input	SDI Output	Processing Delay			
				Async or Isochrone Inputs		Synced & Phase-Aligned Inputs	
				Minimum	Maximum	59Hz	50Hz
OFF	Input	1080i	ALL	2 fields	2 fields	33 ms	40 ms
		720p, 1080p	ALL	2 frames	2 frames	33 ms	40 ms
	URS, External	1080i	ALL	12 ms + 1 field	12 ms + 3 fields	33 ms	40 ms
		720p, 1080p	ALL	12 ms + 1 frame	12 ms + 2 frames	33 ms	40 ms
ON	Input	1080p	1080p	< 4 lines	< 4 lines	< 4 lines	< 4 lines

The XIP-3911 or XIP-3901 has an integrated frame sync that supports synchronous and asynchronous SDI input signals. The input signals will be synchronized and realigned to either the URS or External Reference.

The frame sync behaves like a frame buffer. It also supports frame skips/repeats in the case of an asynchronous SDI input. When an input error occurs, it freezes to the last valid field/frame.

Min. Delay	Ref	Signal	SDI Input	SDI Output	Skip/Repeat Period	Freeze on Input Error
OFF	Input	ALL	ALL	ALL	N/A	None
	URS, External	Video	HD/1080i	ALL	2 fields	Last valid field
			HD/720p	ALL	1 frame	Last valid frame
			3G Level A	ALL	1 frame	Last valid frame
			3G Level B DL	12G	1 frame	Last valid frame
				3G Level A	1 frame	Last valid frame
				Quad Link 3G Level A	1 frame	Last valid frame
				3G Level B DL	2 frames	Last valid frame
			Quad Link 3G Level B DL	2 frames	Last valid frame	
	Audio	PCM	N/A	Tracking during 15 seconds per frame	Muted	
Non-PCM		N/A	Instant catch-up	Muted		
Metadata	ALL	N/A	Lost when skipped, duplicated when repeated	Blanked		
ON	ALL	ALL	ALL	ALL	N/A	None

Deglitcher Tab

For each processing channel, select the appropriate deglitcher mode (ON or OFF) using the pulldown menu.

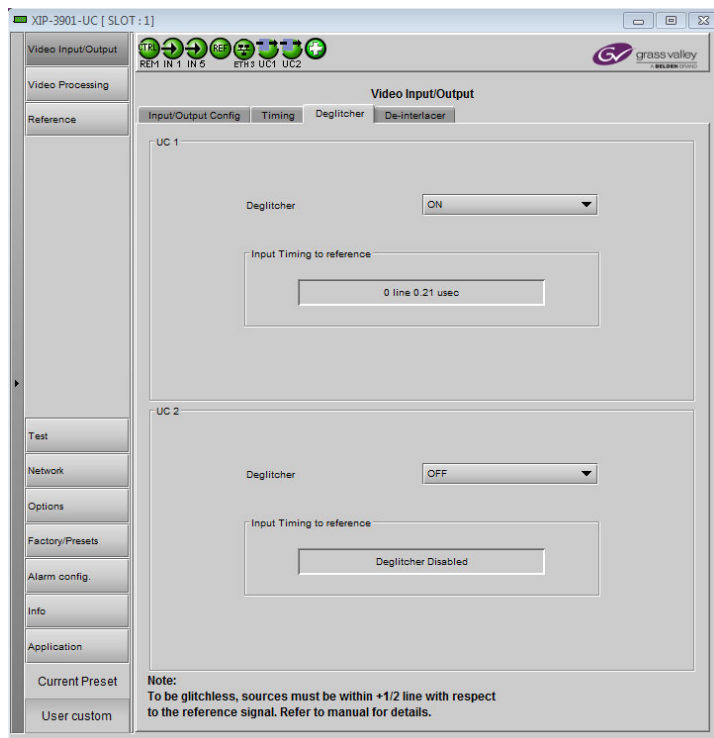

Figure 7-5: *Deglitcher Tab*

When the deglitcher is enabled, the card supports a hotswitch between upstream signals without producing a freeze on the frame sync, and without producing artifacts on the output.

The deglitcher must be disabled when the input is asynchronous to the reference. Otherwise, it will create audio and video glitches at the output.

For this mode to function correctly, the following requirements must be met:

- The two inputs must be synchronized to the reference
- They must be phased within one line of each other
- They must be phased to within $\pm \frac{1}{2}$ line of the HREF of the reference signal

The offset from the VREF can be variable, but a distance of greater than 10 lines could create an artifact in the active video. If the two signals are more than one line apart, a vertical jump will occur at the moment of switching that is proportional to the number of vertical lines of offset between the two signals. This will last for only one frame. For more information about using clean switch regions to perform glitch-free switches, see [Clean Switch Regions and Examples](#), on page 109.

The Input Timing to Reference box reports any difference in timing between the input and reference when the transition occurs. When the deglitcher is disabled, it will display “Deglitcher Disabled”. When the deglitcher is enabled, it can display one of the following error messages in red:

- **Missing Reference:** The External or URS reference source is missing.
- **Locked on Input:** The reference source is set to Input.
- **Video Error:** There is an error with the input.

De-interlacer Tab

Each processing channel has its own de-interlacer used during interlaced sources. The Film Mode and Video Over Film settings can either be set to **On** or **Off**. By default, both are set to **On** for optimal performance.

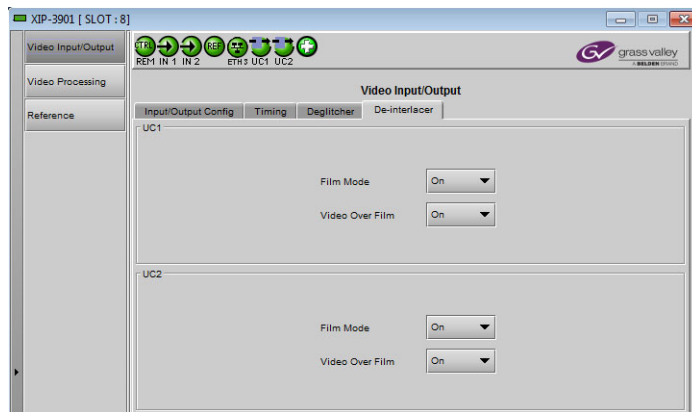

Figure 7-6: Video I/O De-interlacer

Property	Description
Film Mode	Some interlaced video sources are film-based, originating from 24p film images. When Film Mode is on, the de-interlacer will monitor the input for this type of source. When detected, it will merge the fields to recreate the original 24p image, thereby avoiding de-interlacer artifacts prior to scaling and upconversion. Film detection is provided for 3:2, 2:2 (59 Hz and 50 Hz sources) and 5:5 sequences.
Video Over Film	Video Over Film is available only when Film Mode is enabled. When Video Over Film is on, the de-interlacer will detect video over film content and bypass field-merging on certain video regions such as scrolling video characters over an entire film frame, thereby preventing any unwanted combing effects.

Video Input/Output Panel (XIP-3901-DC)

Input/Output Config Tab

This panel allows you to configure the settings for the two downconverters. Each can be configured independently.

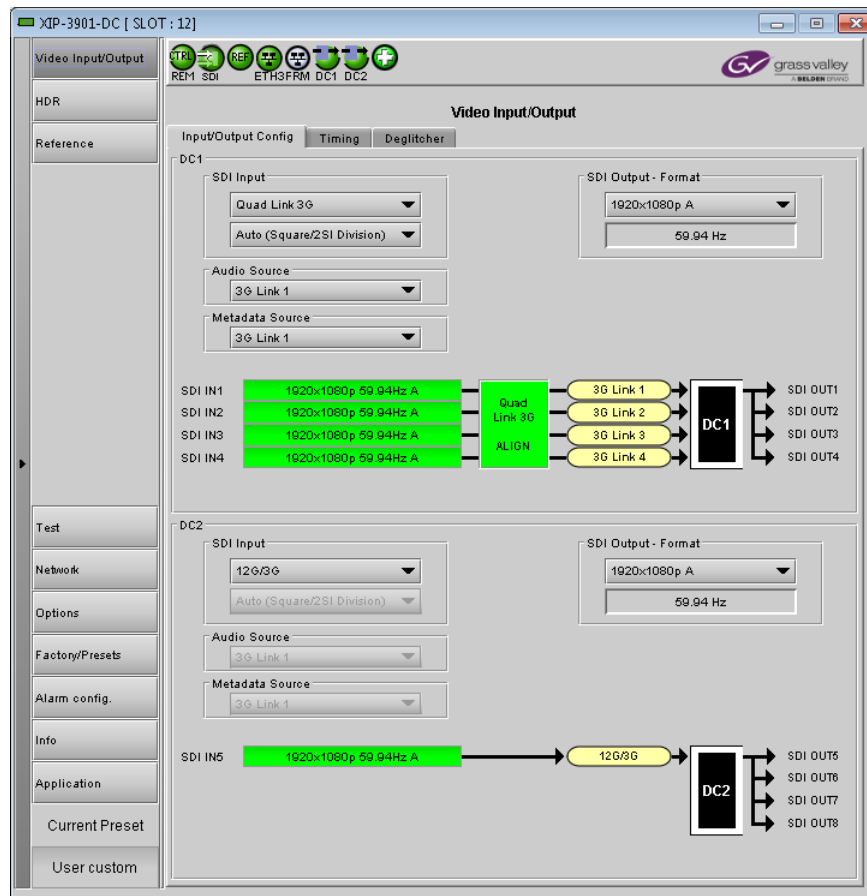

Figure 7-7: Video I/O Config

Use the pulldown menus to configure these parameters:

Parameter	Settings	Note	
SDI Input	SDI Transport	Quad Link 3G (default) 12G/3G	1
	2160-Line Data Mapping	Auto (Square/2SI Division) (default) 2SI Division Square Division	2
Audio Source	3G Link 1 to 4. Set the SDI input link to receive the audio source. Default value is 3G Link 1.	–	
Metadata Source	3G Link 1 to 4. Set the SDI input link to receive the metadata source. Default value is 3G Link 1.	–	

Parameter		Settings	Note
SDI Output – Format	SDI Output – Resolution	1920x1080p A (default) 1920x1080p B DL 1920x1080i 1280x720p	3

Note 1: For each processing channel, you must select the format of the SDI input transport using the SDI Input pulldown menu. The choice will depend on the format used by the origin equipment.

- **Quad Link 3G:** The 4K UHD image is split into four full-resolution quadrants, each received on a single 3G link.
- **12G/3G:** The 4K UHD image is received on a single 12G or the HD image on a 3G link.

Note 2: For Quad Link 3G SDI Transport, you must also select how 2160-Line Data Mapping is detected.

- **Auto (Square/2SI Division):** Automatically detects the mapping type based on the incoming Video Payload ID (Transfer Characteristic, Colorimetry, and Bit depth) on the first link (this setting may not be able to automatically detect certain legacy signals).
- **2SI Division:** Assumes 2SI Division regardless of the incoming Video Payload ID (Transfer Characteristic, Colorimetry, and Bit depth).
- **Square Division:** Assumes Square Division regardless of the incoming Video Payload ID (Transfer Characteristic, Colorimetry, and Bit depth).

2160-Line Data Mapping settings are ignored when the SDI Input is set to 12G/3G.

Note 3: The frame rate (59.94 Hz or 50 Hz) of the selected SDI output resolution is reported underneath the SDI Output - Resolution menu.

A diagram of the downconversion process is displayed underneath the settings for each processing channel. The status for each input SDI will be either green (no error) or red (error). In the event of an error, you can mouse over this field to display a tooltip with more details.

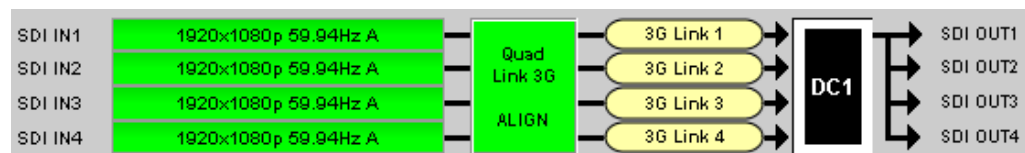

Figure 7-8: Downconversion Diagram

The possible errors are as follows:

- **No Carrier:** No SDI Carrier is detected.
- **No Error:** No errors are detected.
- **Video/TRS Error:** The received video has TRS errors.
- **Not Supported:** The received video format is not supported.
- **Reference Mismatch:** The received video does not match the reference frame rate.
- **Wrong Link:** Received the wrong Quad Link 3G link on 2SI Division.
- **Quad Link 3G Error:** The received Quad Link 3G has different video formats.
- **Unexpected Format:** Did not receive the video format you selected.

Quad Link 3G ALIGN monitors the timing of the four link inputs. The timing difference between the Quad Link 3G links shall not exceed 400 ns, as per SMPTE ST4255.

Status	Quad Link 3G ALIGN	
Gray	No carrier on Quad Link 3G links	
Green	Timing difference between Quad Link 3G links does not exceed the internal buffer	
Red	Timing difference between Quad Link 3G links exceeds the internal buffer	

Timing Tab

For each downconverter and output resolution, you can adjust the timing relative to the reference. The vertical setting applies to all output formats, whereas the horizontal settings are specific to individual output formats. To adjust the timing, use the slider or type a value into the data box on the right of the slider.



Figure 7-9: Video I/O Timing

The sliders can be adjusted as follows:

Adjustment	Range (50 Hz)	Range (59 Hz)
Vertical (Lines)	16 to +16	16 to +16
1920x1080p (A and B DL) Horizontal (msec)	0 to 17.771 msec	0 to 14.825 msec
1920x1080i Horizontal (msec)	0 to 35.542 msec	0 to 29.646 msec

Adjustment	Range (50 Hz)	Range (59 Hz)
1280x720p Horizontal (msec)	0 to 26.653 msec	0 to 22.231 msec

This section also displays the Processing Delay in milliseconds (ms) for each channel so you can manage the processing delay on your system. For more details about processing delay, see the table below.

Ref	SDI Input	SDI Output	Processing Delay			
			Async or Isochrone Inputs		Synced & Phase-Aligned Inputs	
			Min	Max	59Hz	50Hz
Input	ALL	ALL	2 frames	2 frames	33 ms	40 ms
URS, External	3G Level A	ALL	12 ms	12 ms + 1 frame	17 ms	20 ms
	3G Level B DL	HD	12 ms	12 ms + 1 frame	17 ms	20 ms
		3G Level A	12 ms	12 ms + 1 frame	17 ms	20 ms
	3G Level B DL	3G Level B DL	12 ms	12 ms + 2 frames	33 ms	40 ms
	12G	ALL	12 ms + 1 frame	12 ms + 2 frames	33 ms	40 ms
	Quad Link 3G Level A	ALL	12 ms + 1 frame	12 ms + 2 frames	33 ms	40 ms
	Quad Link 3G Level B DL	HD	12 ms + 1 frame	12 ms + 2 frames	33 ms	40 ms
		3G Level A	12 ms + 1 frame	12 ms + 2 frames	33 ms	40 ms
3G Level B DL		12 ms + 2 frames	12 ms + 4 frames	67 ms	80 ms	

The XIP-3911 or XIP-3901 has an integrated frame sync that supports synchronous and asynchronous SDI input signals. The input signals will be synchronized and realigned to either the URS or External Reference.

The frame sync behaves like a frame buffer. It also supports frame skips/repeats in the case of an asynchronous SDI input. When an input error occurs, it freezes to the last valid field/frame.

Ref	Signal	SDI Input	SDI Output	Skip/Repeat Period	Freeze on Input Error
Input	ALL	ALL	ALL	N/A	None

Ref	Signal	SDI Input	SDI Output	Skip/Repeat Period	Freeze on Input Error
URS, External	Video	12G,	ALL	1 frame	Last valid frame
		3G Level A	ALL	1 frame	Last valid frame
		Quad Link 3G Level A	ALL	1 frame	Last valid frame
		3G Level B DL	3G Level A	1 frame	Last valid frame
			3G Level B DL	2 frames	Last valid frame
		Quad Link 3G Level B DL	3G Level A	1 frame	Last valid frame
	3G Level B DL		2 frames	Last valid frame	
Audio	PCM	N/A	Tracking during 15 seconds per frame	Muted	
	Non-PCM	N/A	Instant catch-up	Muted	
Metadata	ALL	N/A	Lost when skipped, duplicated when repeated	Blanked	

Deglitcher Tab

For each processing channel, select the appropriate deglitcher mode (ON or OFF) using the pulldown menu.

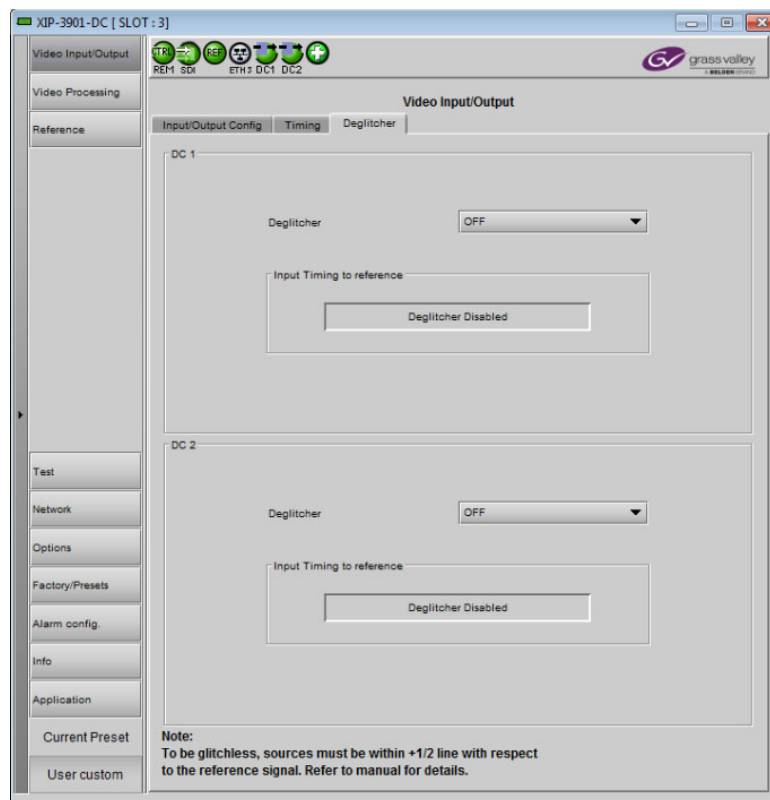

Figure 7-10: Deglitcher Tab

When the deglitcher is enabled, the card supports a hot switch between upstream signals without producing a freeze on the frame sync, and without producing artifacts on the output.

The deglitcher must be disabled when the input is asynchronous to the reference. Otherwise, it will create audio and video glitches at the output.

For this mode to function correctly, the following requirements must be met:

- The two inputs must be synchronized to the reference
- They must be phased within one line of each other
- They must be phased to within $\pm \frac{1}{2}$ line of the HREF of the reference signal

The offset from the VREF can be variable, but a distance of greater than 10 lines could create an artifact in the active video. If the two signals are more than one line apart, a vertical jump will occur at the moment of switching that is proportional to the number of vertical lines of offset between the two signals. This will last for only one frame. For more information about using clean switch regions to perform glitch-free switches, see [Clean Switch Regions and Examples](#), on page 109.

The Input Timing to Reference box reports any difference in timing between the input and reference when the transition occurs. Since the XIP-3901-DC supports multiple links, the measurement displayed is taken from the first link (shown as SDI IN 1 in the Input/Output Config tab). When the deglitcher is disabled, it will display "Deglitcher Disabled". When the deglitcher is enabled, it can display one of the following messages in red:

- **Missing Reference:** The External or URS reference source is missing.
- **Locked on Input:** The reference source is set to Input.
- **Video Error:** There is an error with the input.

Video Input/Output Panel (XIP-3901-FS)

Input/Output Config Tab

This panel allows you to configure the settings for the two synchronizers. Each can be configured independently.

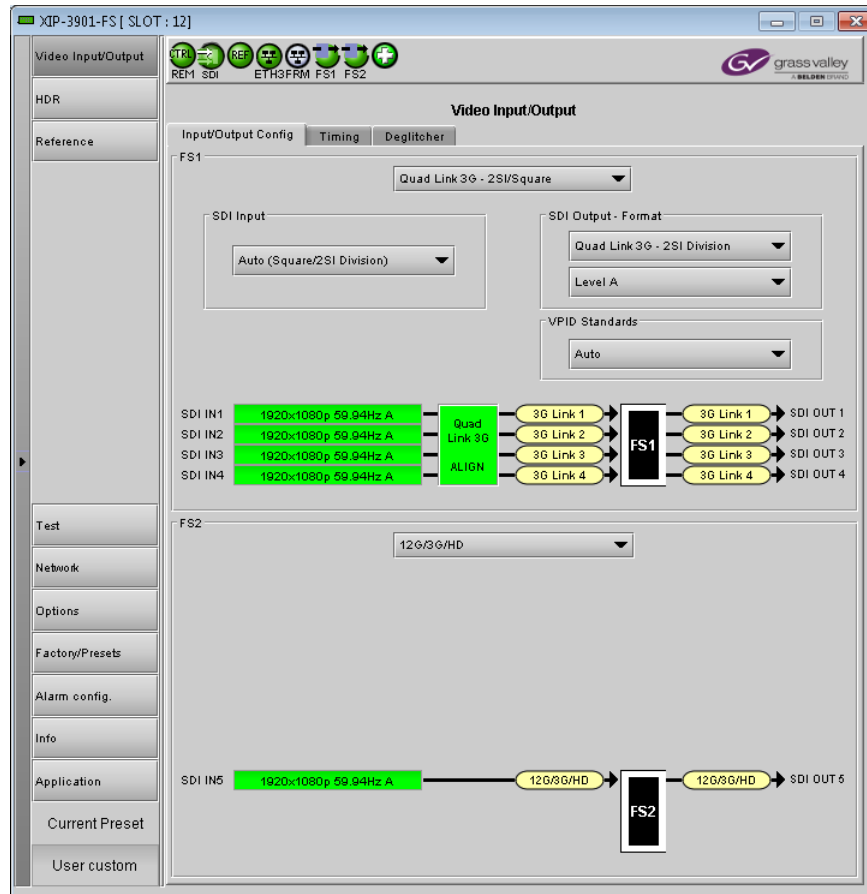

Figure 7-11: Video I/O Config

Use the topmost pulldown menu to select an operation mode. Depending on the selected mode, you may also need to select an SDI input format, SDI output format, and/or Video Payload ID (Transfer Characteristic, Colorimetry, and Bit depth) standards.

Operation Mode	Setting Type	Settings	Note
12G/3G/HD	N/A	N/A	N/A
Quad Link 3G (default)	N/A	N/A	N/A
3G Level A/B DL	SDI Output – Format (3G Mapping)	Level A (default) Level B Dual-Link	3

Operation Mode	Setting Type	Settings	Note
Quad Link 3G - 2SI/Square	SDI Input (2160p Data Mapping)	Auto (Square/2SI Division) (default) 2SI Division Square Division	1
	SDI Output - Format (2160p Data Mapping)	Quad Link 3G - Square Division Quad Link 3G - 2SI Division (default)	2
	SDI Output - Format (3G Mapping)	Level A (default) Level B Dual-Link	3
	Video Payload ID (Transfer Characteristic, Colorimetry, and Bit depth) Standards *only active for 2SI Division	Auto (default) 3Gbps legacy (SMPTE 4251)	4
Quad Link 3G to 12G	SDI Input (2160p Data Mapping)	Auto (Square/2SI Division) (default) 2SI Division Square Division	1
12G to Quad Link 3G	SDI Output - Format (2160p Data Mapping)	Quad Link 3G - Square Division Quad Link 3G - 2SI Division (default)	2
	SDI Output - Format (3G Mapping)	Level A (default) Level B Dual-Link	3
	Video Payload ID (Transfer Characteristic, Colorimetry, and Bit depth) Standards *only active for 2SI Division	Auto (default) 3Gbps legacy (SMPTE 4251)	4

Note 1: Using the Auto setting, the XIP-3901-FS can automatically detect whether the input format is Square Division or 2SI Division. You can also choose to consider the input as either Square Division or 2SI Division.

Note 2: For the Quad Link 3G SDI Output - Format setting, you must select which 2160p Data Mapping to use (Square Division or 2SI Division). The choice will depend on the format used by the destination equipment.

- **Quad Link 3G – Square Division:** The 4K image is split into four full-resolution quadrants, each sent on a single 3G link.
- **Quad Link 3G – 2SI Division:** The 4K image is sub-sampled into four full-frame images, each at half the vertical and horizontal resolution.

Note 3: The XIP-3901-FS supports two of the mappings of video into the serial digital interface defined by SMPTE 424M. 3G Mapping settings are ignored when the SDI Output is set to 12G.

- The Level A format is the direct mapping of uncompressed 1080p (up to 60 fps) video into a serial digital interface at the nominal 3 Gbps.
- The Level B DL (Dual-Link) format is the mapping of Dual-Link HDSDI/SMPTE 372M (for example, 1080p up to 60 fps) in a single serial digital interface at the nominal 3 Gbps.

Note 4: Usually, 2-Sample Interleave outputs have a different Video Payload ID (Transfer Characteristic, Colorimetry, and Bit depth) on each link, per SMPTE 4255. Some downstream equipment may not support this standard, so the use of SMPTE 4251 Video

Payload IDs (Transfer Characteristic, Colorimetry, and Bit depth) can be forced by selecting 3Gbps legacy in the Video Payload ID (Transfer Characteristic, Colorimetry, and Bit depth) Standards pulldown menu. Video Payload ID (Transfer Characteristic, Colorimetry, and Bit depth) Standards settings are ignored when the SDI Output is set to 3G or 12G.

Video Payload ID (Transfer Characteristic, Colorimetry, and Bit depth) Standards	Quad Link 3G	
	Square Division	2SI Division
Auto	SMPTE 4251	SMPTE 4255
3 Gbps legacy	SMPTE 4251	SMPTE 4251

A diagram of the synchronization process is displayed underneath the settings for each synchronizer. The status for each input SDI will be either green (no error) or red (error). In the event of an error, you can mouse over this field to display a tooltip with more details.

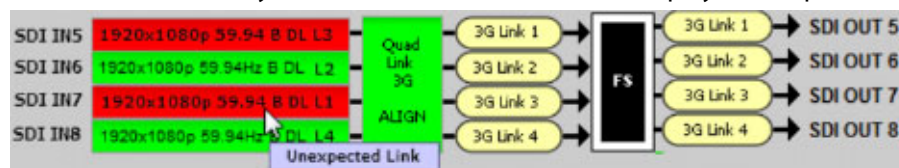

Figure 7-12: Synchronization Diagram

The possible errors are as follows:

- **No Carrier:** No SDI Carrier is detected.
- **No Error:** No errors are detected.
- **Video/TRS Error:** The received video has TRS errors.
- **Not Supported:** The received video format is not supported.
- **Reference Mismatch:** The received video does not match the reference frame rate.
- **Wrong Link:** Received the wrong Quad Link 3G link on 2SI Division.
- **Quad Link 3G Error:** The received Quad Link 3G has different video formats.
- **Unexpected Format:** Did not receive the video format you selected.

Quad Link 3G ALIGN monitors the timing of the four link inputs. The timing difference between the Quad Link 3G links shall not exceed 400 ns, as per SMPTE ST4255.

Status	Quad Link 3G ALIGN
Gray	No carrier on Quad Link 3G links
Green	Timing difference between Quad Link 3G links does not exceed the internal buffer
Red	Timing difference between Quad Link 3G links exceeds the internal buffer

Timing Tab

For each synchronizer and output resolution, you can adjust the timing relative to the reference. The vertical setting applies to all output formats, whereas the horizontal settings are specific to individual output formats. To adjust the timing, use the slider or type a value into the data box on the right of the slider.



Figure 7-13: Video I/O Timing

The sliders can be adjusted as follows:

Adjustment	Range (50 Hz)	Range (59 Hz)
Vertical (Lines)	16 to +16	16 to +16
1920x1080p (A and B DL) Horizontal (msec)	0 to 17.771 msec	0 to 14.825 msec
1920x1080i Horizontal (msec)	0 to 35.542 msec	0 to 29.646 msec
1280x720p Horizontal (msec)	0 to 26.653 msec	0 to 22.231 msec
Additional Frame Delay	0 to 10	0 to 10

Additional frame delay is usually selected in steps of one frame, but some exceptions exist for 1080p B DL where you can only select frames in multiples of two. The following table lists the number of frame steps for each combination of operation modes and SDI inputs and outputs.

Operation Mode	SDI Input	SDI Output	Frame Steps
12G/3G/HD	1080p A, 1080i, 720p, 2160p	N/A	1
	1080p B DL	N/A	2
Quad Link 3G	Quad Link 3G Level A	N/A	1
	Quad Link 3G Level B DL	N/A	2

Operation Mode	SDI Input	SDI Output	Frame Steps
3G Level A/B DL	1080p A	1080p A	1
		1080p B DL	1
	1080p B DL	1080p A	1
		1080p B DL	2
Quad Link 3G - 2SI/Square	Quad Link 3G Level A	1080p A	1
		1080p B DL	1
	Quad Link 3G Level B DL	1080p A	1
		1080p B DL	2
Quad Link 3G to 12G	Quad Link 3G Level A, Quad Link 3G Level B DL	2160p	1
12G to Quad Link 3G	2160p	1080p A	1
		1080p B DL	1

This section also displays the Processing Delay in milliseconds (ms) for each channel so you can manage the processing delay on your system. For more details about processing delay, see the tables below for the various operation modes.

12G/3G/HD and Quad Link 3G

Min. Delay	Ref	Operation Mode	SDI Input (SDI output = SDI input)	Processing Delay			
				Async or Isochrone Inputs		Synced & Phase-Aligned Inputs	
				Min.	Max.	59 Hz	50Hz
OFF	Input	ALL	ALL	2 frames	2 frames	33 ms	40 ms
		12G/3G/HD	12G, 3G Level A	3 ms	3 ms + 1 frame	17 ms	20 ms
			HD	3 ms	3 ms + 2fields	33 ms	40 ms
			3G Level B DL	3 ms	3 ms + 2 frames	33 ms	40 ms
		Quad Link 3G	Quad Link 3G Level A	3 ms	3 ms + 1 frame	17 ms	20 ms
			Quad Link 3G Level B DL	3 ms	3 ms + 2 frames	33 ms	40 ms

Min. Delay	Ref	Operation Mode	SDI Input (SDI output = SDI input)	Processing Delay			
				Async or Isochrone Inputs		Synced & Phase-Aligned Inputs	
				Min.	Max.	59 Hz	50Hz
ON	Input	ALL	HD	< 3 lines	< 3 lines	< 3 lines	< 4 lines
			3G Level A	< 3 lines	< 3 lines	< 3 lines	< 3 lines
			3G Level B DL	< 6 lines	< 6 lines	< 6 lines	< 6 lines
			12G	< 4 lines	< 4 lines	< 4 lines	< 4 lines
			2SI Quad Link 3G Level A	< 4 lines	< 4 lines	< 4 lines	< 4 lines
			2SI Quad Link 3G Level B DL	< 7 lines	< 7 lines	< 7 lines	< 7 lines
			SQ Quad Link 3G Level A	< 3 lines	< 3 lines	< 3 lines	< 3 lines
			SQ Quad Link 3G Level B DL	< 6 lines	< 6 lines	< 6 lines	< 6 lines

For the 12G/3G/HD and Quad Link 3G operating modes, Minimum Delay can be enabled on a channel. The reference source will be internally forced to Input for the channel, and your settings for the reference source will be ignored (see [Reference Panel](#), on page 116 for more information). The Frame Sync and Deglitcher will be bypassed, and the Test Tone Generator will no longer be available. The following warning message will appear to request confirmation to enable Minimum Delay:

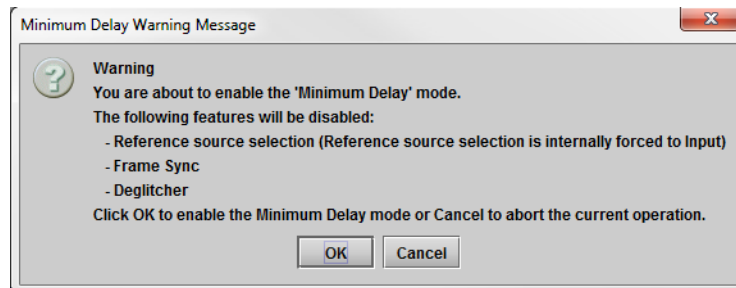

Figure 7-14: Disabled Features

3G Level A/B DL

Ref	SDI Input	SDI Output	Processing Delay			
			Async or Isochrone Inputs		Synced & Phase-Aligned Inputs	
			Min.	Max.	59 Hz	50Hz
Input	ALL	ALL	2 frames	2 frames	33 ms	40 ms

Ref	SDI Input	SDI Output	Processing Delay			
			Async or Isochrone Inputs		Synced & Phase-Aligned Inputs	
			Min.	Max.	59 Hz	50Hz
URS, External	3G Level A	ALL	3 ms	3 ms + 1 frame	17 ms	20 ms
	3G Level B DL	3G Level A	3 ms	3 ms + 1 frame	17 ms	20 ms
		3G Level B DL	3 ms	3 ms + 2 frames	33 ms	40 ms

Quad Link 3G – 2SI/Square

Ref	SDI Input	SDI Output	Processing Delay			
			Async or Isochrone Inputs		Synced & Phase-Aligned Inputs	
			Min.	Max.	59Hz	50Hz
Input	ALL	ALL	2 frames	2 frames	33 ms	40 ms

Ref	SDI Input	SDI Output	Processing Delay			
			Async or Isochrone Inputs		Synced & Phase-Aligned Inputs	
			Min.	Max.	59Hz	50Hz
URS, External	2SI Quad Link 3G Level A	2SI Quad Link 3G Level A	3 ms	3 ms + 1 frame	17 ms	20 ms
		2SI Quad Link 3G Level B DL	3 ms	3 ms + 1 frame	17 ms	20 ms
	2SI Quad Link 3G Level B	2SI Quad Link 3G Level A	3 ms	3 ms + 1 frame	17 ms	20 ms
		2SI Quad Link 3G Level B DL	3 ms	3 ms + 2 frames	33 ms	40 ms
	2SI Quad Link 3G Level A	SQ Quad Link 3G Level A	3 ms + 1 frame	3 ms + 2 frames	33 ms	40 ms
		SQ Quad Link 3G Level B DL	3 ms + 1 frame	3 ms + 2 frames	33 ms	40 ms
	2SI Quad Link 3G Level B	SQ Quad Link 3G Level A	3 ms + 1 frame	3 ms + 2 frames	33 ms	40 ms
		SQ Quad Link 3G Level B DL	3 ms + 2 frames	3 ms + 4 frames	67 ms	80 ms
	SQ Quad Link 3G Level A	2SI Quad Link 3G Level A	3 ms + 1 frame	3 ms + 2 frames	33 ms	40 ms
		2SI Quad Link 3G Level B DL	3 ms + 1 frame	3 ms + 2 frames	33 ms	40 ms
	SQ Quad Link 3G Level B	2SI Quad Link 3G Level A	3 ms + 1 frame	3 ms + 2 frames	33 ms	40 ms
		2SI Quad Link 3G Level B DL	3 ms + 2 frames	3 ms + 4 frames	67 ms	80 ms
	SQ Quad Link 3G Level A	SQ Quad Link 3G Level A	3 ms	3 ms + 1 frame	17 ms	20 ms
		SQ Quad Link 3G Level B DL	3 ms	3 ms + 1 frame	17 ms	20 ms
	SQ Quad Link 3G Level B	SQ Quad Link 3G Level A	3 ms	3 ms + 1 frame	17 ms	20 ms
		SQ Quad Link 3G Level B DL	3 ms	3 ms + 2 frames	33 ms	40 ms

Quad Link 3G to 12G

Ref	SDI Input	SDI Output	Processing Delay			
			Async or Isochrone Inputs		Synced & Phase-Aligned Inputs	
			Min.	Max.	59Hz	50Hz
Input	ALL	12G	2 frames	2 frames	33 ms	40 ms
URS, External	2SI Quad Link 3G Level A	12G	3 ms	3 ms + 1 frame	17 ms	20 ms
	2SI Quad Link 3G Level B DL	12G	3 ms	3 ms + 1 frame	17 ms	20 ms
	SQ Quad Link 3G Level A	12G	3 ms + 1 frame	3 ms + 2 frames	33 ms	40 ms
	SQ Quad Link 3G Level B DL	12G	3 ms + 1 frame	3 ms + 2 frames	33 ms	40 ms

12G to Quad Link 3G

Ref	SDI Input	SDI Output	Processing Delay			
			Async or Isochrone Inputs		Synced & Phase-Aligned Inputs	
			Min.	Max.	59Hz	50Hz
Input	12G	ALL	2 frames	2 frames	33 ms	40 ms
URS, External	12G	2SI Quad Link 3G Level A	3 ms	3 ms + 1 frame	17 ms	20 ms
	12G	2SI Quad Link 3G Level B DL	3 ms	3 ms + 1 frame	17 ms	20 ms
	12G	SQ Quad Link 3G Level A	3 ms + 1 frame	3 ms + 2 frames	33 ms	40 ms
	12G	SQ Quad Link 3G Level B DL	3 ms + 1 frame	3 ms + 2 frames	33 ms	40 ms

The XIP-3911 or XIP-3901 has an integrated frame sync that supports synchronous and asynchronous SDI input signals. The input signals will be synchronized and realigned to either the URS or External Reference.

The frame sync behaves like a frame buffer. It also supports frame skips/repeats in the case of an asynchronous SDI input. When an input error occurs, it freezes to the last valid field/frame.

Min. Delay	Ref	Signal	SDI Input	SDI Output	Skip/Repeat Period	Freeze on Input Error
OFF	Input	ALL	ALL	ALL	N/A	None
	URS, External	Video	HD/1080i	HD/1080i	2 fields	Last valid field
			HD/720p	HD/720p	1 frame	Last valid frame
			3G Level A	ALL	1 frame	Last valid frame
			12G	ALL	1 frame	Last valid frame
			3G Level B DL	3G Level A	1 frame	Last valid frame
				3G Level B DL	2 frames	Last valid frame
			Quad Link 3G Level A	ALL	1 frame	Last valid frame
			Quad Link 3G Level B DL	Quad Link 3G Level A	1 frame	Last valid frame
				Quad Link 3G Level B DL	2 frames	Last valid frame
			Audio	PCM	N/A	Tracking during 15 seconds per frame
	Non-PCM	N/A		Instant catch-up	Muted	
	Metadata	ALL	N/A	Lost when skipped, duplicated when repeated	Blanked	
ON	ALL	ALL	ALL	ALL	N/A	None

Deglitcher Tab

For each synchronizer, select the appropriate deglitcher mode (ON or OFF) using the pulldown menu.

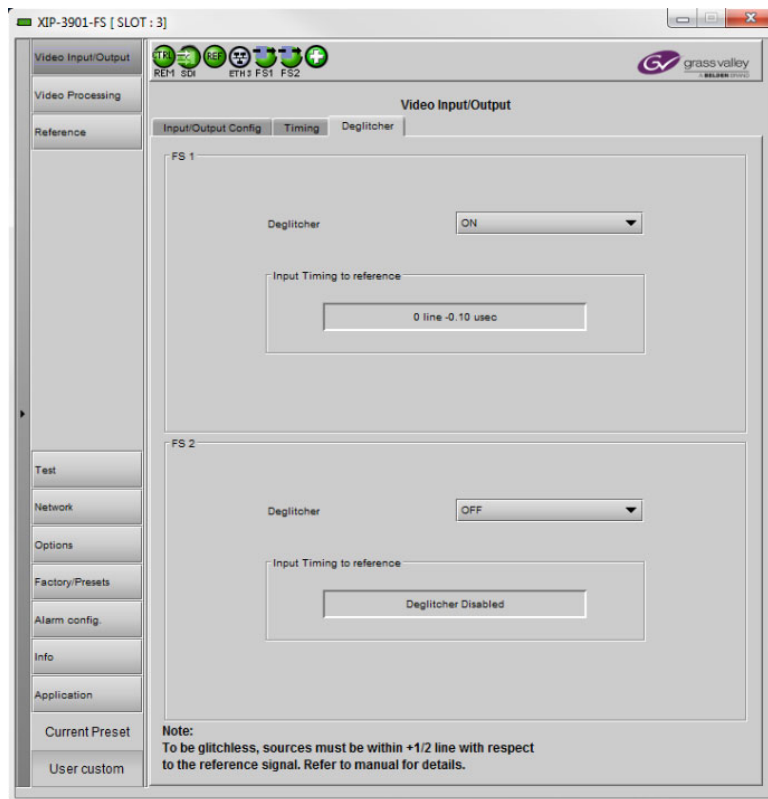

Figure 7-15: *Deglitcher Tab*

When the deglitcher is enabled, the card supports a hot switch between upstream signals without producing a freeze on the frame sync, and without producing artifacts on the output.

The deglitcher must be disabled when the input is asynchronous to the reference. Otherwise, it will create audio and video glitches at the output.

For this mode to function correctly, the following requirements must be met:

- The two inputs must be synchronized to the reference
- They must be phased within one line of each other
- They must be phased to within $\pm \frac{1}{2}$ line of the HREF of the reference signal

The offset from the VREF can be variable, but a distance of greater than 10 lines could create an artifact in the active video. If the two signals are more than one line apart, a vertical jump will occur at the moment of switching that is proportional to the number of vertical lines of offset between the two signals. This will last for only one frame. For more information about using clean switch regions to perform glitch-free switches, see [Clean Switch Regions and Examples](#), on page 109.

The Input Timing to Reference box reports any difference in timing between the input and reference when the transition occurs. When the deglitcher is disabled, it will display

“Deglitcher Disabled”. When the deglitcher is enabled, it can display one of the following error messages in red:

- **Missing Reference:** The External or URS reference source is missing.
- **Locked on Input:** The reference source is set to Input.
- **Video Error:** There is an error with the input.

Clean Switch Regions and Examples

To perform a glitch-free switch between two sources, they must be in the same clean switch region. A clean switch region is contained within $\pm \frac{1}{2}$ line about an H=0 point in the reference signal, as shown by the dotted lines in the figure. There is a clean switch region centered on every H interval. As you can see, vertical alignment with the reference is not important for the deglitcher to operate properly.

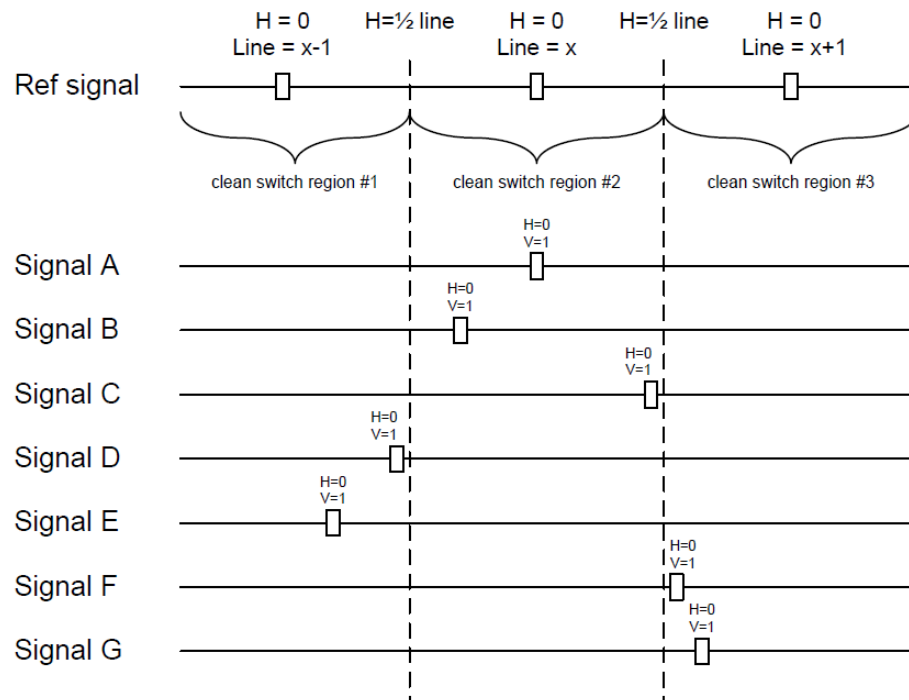

Figure 7-16: Clean Switch Regions

You may switch between signals A, B or C, without any glitches, and also between the D<>E and F<>G signals. Any other transition, like A<>D, will cause a vertical image shift for one frame.

To determine whether a clean hot switch is possible, you need to determine whether the two sources lie in the same clean switch region. You can measure the position of the signals with respect to the reference:

- Use the deglitcher tab in iControl (Video Input/Output > Deglitcher)

When the deglitcher is enabled, the alignment offset between the reference signal and the input signal can be displayed for either of these sources. Knowing the offset for both input signals, you can determine if they are in the same clean switch region. If so, any hot switch between those two signals will be glitch-free.

To determine the limits of a clean switch region, you must know the input's line length in μs . The first region is delimited by $+\frac{1}{2}$ line and $\frac{1}{2}$ line of the reference. For example, with an HD (1080i59) signal, the line length is $29.65 \mu\text{s}$ and so the first region lies between $14.83 \mu\text{s}$ and $14.83 \mu\text{s}$. Other regions can be found by adding or removing a multiple of line length to the two boundaries.

Example: For an HD (1080i59) input signal, we have these clean switch regions:

- 1 line and $14.83 \mu\text{s}$ to 0 line and $14.83 \mu\text{s}$;
- 0 line and $14.83 \mu\text{s}$ to 0 line and $14.83 \mu\text{s}$;
- 0 line and $14.83 \mu\text{s}$ to 1 line and $14.83 \mu\text{s}$; etc.

Practical examples:

Example 1: We have two HD (1080i59) sources, one that indicates an offset of $10 \mu\text{s}$ with respect to the reference (A) and the other an offset of $20 \mu\text{s}$ (B). We know that a clean switch region limit is present at $\frac{1}{2}$ line, which corresponds to $14.83 \mu\text{s}$. We can now determine that this switch will not be clean, because the two sources are on opposite sides of the limit and are therefore not in the same clean switch region.

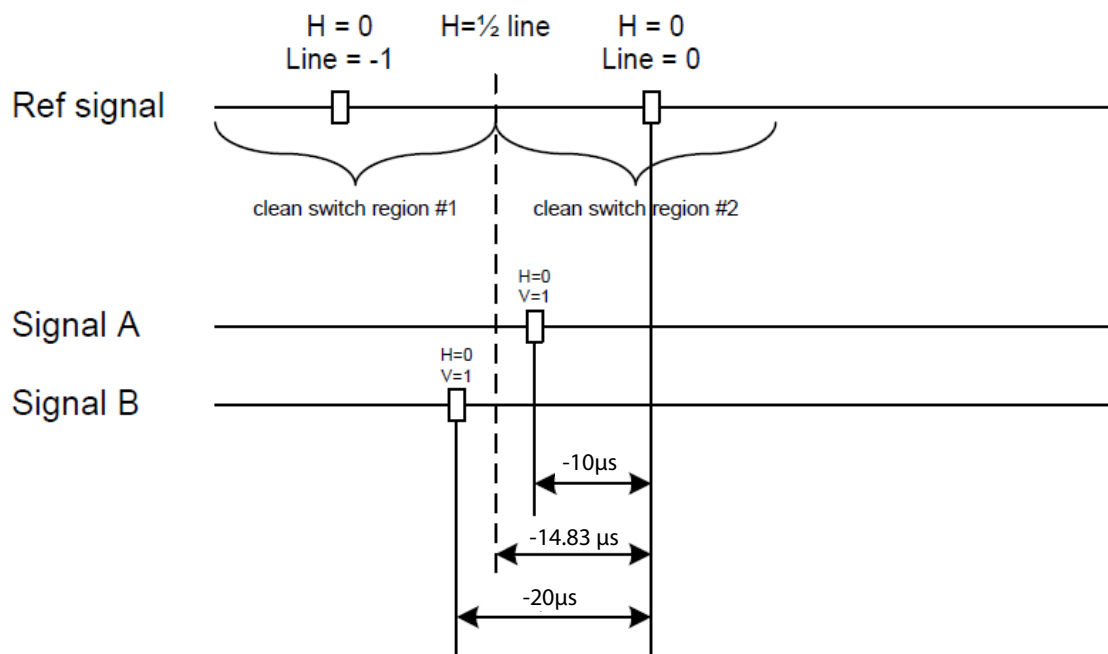

Figure 7-17: Clean Switch Regions Example 1

Example 2: We have two HD (1080i59) sources, one that indicates an offset of $30 \mu\text{s}$ with respect to the reference (A) and the other an offset of $20 \mu\text{s}$ (B). We know that a clean switch region limit is present at $+\frac{1}{2}$ line and another one at $\frac{1}{2}$ line plus one line. These correspond to $14.83 \mu\text{s}$ and $44.48 \mu\text{s}$. We can now determine that this switch will be clean, because the two sources are inside the same clean switch region.

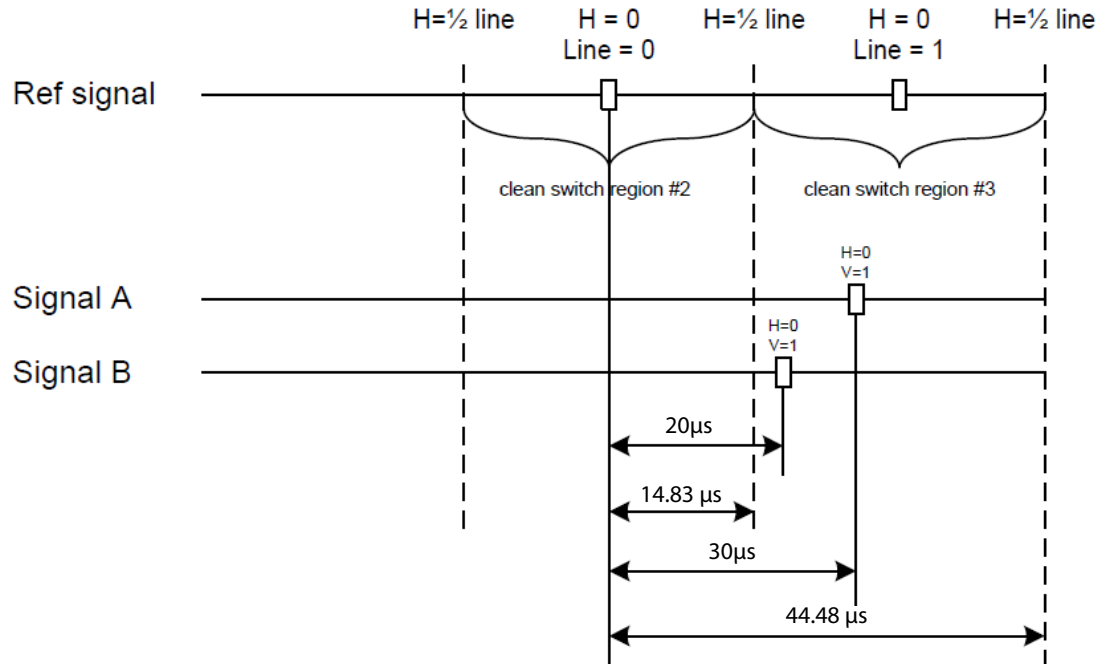

Figure 7-18: Clean Switch Regions Example 2

HDR Panel

The HDR panel has two tabs (**UC1** and **UC2 / DC1** and **DC2 / FS1** and **FS2**); one for each of XIP-3901-UC / DC / FS's independent processing channels. The configuration of the **UC2 / DC2 / FS2** tab is the same as the **UC1 / DC1 / FS1** tab. Only the configuration of the **UC1** tab is shown below as a representative example for all XIP-3901-UC / DC / FS applications.

UC1&2 / DC1&2 / FS1&2 Tabs

Grass Valley offers its own HDR processing. However, you can decide to use BBC LUTs or to load your own Custom LUTs. Furthermore, we can correct incoming Video Payload ID (Transfer Characteristic, Colorimetry, and Bit depth) without applying any HDR conversion. Use the radio button to select the desired processing. Grass Valley HDR processing is selected by default.

Grass Valley color space conversion internal LUT's, for example, BT.709 to BT2020 and BT.2020 to BT.709 are always available. Other video processing settings can be enabled for each channel by activating the **XIP-3901-UDC-HDR** option. See [Options Panel](#), on page 122 for details about how to activate card options.



Figure 7-19: HDR UC1 / UC2 Tab (Shown on XIP-3901-UC)

Property	Description
Enable	Set to enable color space conversion and dynamic range conversion. When disabled, incoming color space and dynamic range are bypassed without processing. The Applied Conversion statuses will indicate "Bypass". You can change the HDR processing setting values even if processing is disabled, but processing will not be performed. Processing is disabled by default.

Property	Description
Grass Valley LUTs	<p>Set the LUT to use for HDR processing. The following HDR processing setting are available as part of the Grass Valley LUTs:</p> <p>BT.709 to BT.2020 BT.2020 to BT.709 SDR to HLG BT.2100 SDR to PQ BT.2100 HLG BT.2100 to SDR PQ BT.2100 to SDR PQ BT.2100 to HLG BT.2100 HLG BT.2100 to PQ BT.2100 S-Log3 S-Gamut3 to BT.709 800% S-Log3 S-Gamut3 to HLG BT.2100 S-Log3 S-Gamut3 to PQ BT.2100</p>
BBC LUTs	<p>Set the LUT to use for HDR processing. The following HDR processing setting are available as part of the BBC LUTs:</p> <p>SDR to HLG Scene (4-1a - v1.4) SDR to HLG Scene Strict (4-2a - v1.4) SDR to HLG Scene Upmap (6-1a - v1.4) SDR to HLG Scene Upmap Strict (6-2a - v1.4) SDR to HLG Display (3c - v1.4) SDR to HLG Display Upmap (5c - v1.4) HLG to SDR Scene (12-1c - v1.4) HLG to SDR Scene Strict (12-2c - v1.4) HLG to SDR Display (8c - v1.4) HLG to SDR Display Harsh (9c - v1.4) PQ 1000 Nits Full Range to HLG (1c - v1.4) PQ 1000 Nits Narrow Range to HLG (1e - v1.4) PQ 4000 Nits Full Range to HLG (2c - v1.4) PQ 4000 Nits Narrow Range to HLG (2e - v1.4) HLG to PQ 1000 Nits Narrow range (7c - v1.4) SLog3 100% Scene to HLG (10a - v1.4) SLog3 200% Scene to HLG (11a - v1.4) Unity</p>
Custom LUTs	<p>Set the LUT to use for HDR processing. You can pre-load up to 8 custom HDR conversions on the card. These are configured in the Custom LUTs tab.</p>
Only force colorimetry fields in VPID/SDP	<p>Set to force the use of a Video Payload ID (Transfer Characteristic, Colorimetry, and Bit depth). Sometimes, incoming HDR processing is not flagged properly on Video Payload ID (Transfer Characteristic, Colorimetry, and Bit depth). You can use this option to correct the outgoing Video Payload ID (Transfer Characteristic, Colorimetry, and Bit depth):</p> <p>SDR BT.709 Narrow HLG BT.2020 Narrow PQ BT.2020 Narrow PQ BT.2020 Full</p> <p>Note: This application does not use an input SDP file.</p>

Property	Description
HLG BT.2100 to SDR – Input HDR Ref White (nits)	Set the <i>reference white</i> luminance level in nits that will become 100% white in the SDR output. The value range must be between 100 and 1000 nits. The default value is 203 nits. This parameter is only applied when the Grass Valley HLG BT.2100 to SDR LUT is selected.
SDR to HLG BT.2100 – Output HDR Ref White (nits)	Set the <i>reference white</i> luminance level in nits for the HDR output that represents 100% white in the SDR input. The value range must be between 100 and 1000 nits. The default value is 203 nits. This parameter is only applied when the Grass Valley SDR to HLG BT.2100 LUT is selected.
PQ BT.2100 to SDR – Input HDR Ref White (nits)	Set the <i>reference white</i> luminance level in nits that will become 100% white in the SDR output. The value range must be between 100 and 1000 nits. The default value is 203 nits. This parameter is only applied when the Grass Valley PQ BT.2100 to SDR is selected.
PQ BT.2100 to SDR – Input Range	Set the input range to Full or Narrow : Full: 0 to 1023 image mapping range according to SMPTE RP. 2077. Narrow: The standard 64 to 940 image mapping broadcast range. This parameter is only applied when the Grass Valley PQ BT.2100 to SDR LUT is selected.
SDR to PQ BT.2100 – Output HDR Ref White (nits)	Set the <i>reference white</i> luminance level in nits for the HDR output that represents 100% white in the SDR input. The value range must be between 100 and 1000 nits. The default value is 203 nits. This parameter is only applied when the Grass Valley SDR to PQ BT.2100 LUT is selected.
SDR to PQ BT.2100 – Output Range	Set the output range to Full or Narrow : Full: 0 to 1023 image mapping range according to SMPTE RP. 2077. Narrow: The standard 64 to 940 image mapping broadcast range. This parameter is only applied when the Grass Valley SDR to PQ BT.2100 LUT is selected.
Colorimetry	Shows the applied conversion according to the above settings.
Transfer Characteristic	
Range	

Custom LUTs Tab

This tab allows you to load up to 8 custom LUTs (**LUT1** to **LUT8**) that can be selected for use in the **UDC1** / **UDC2** tabs. The XIP only supports files that conform to the Adobe Cube file v1.0 format. Custom LUTs are shared among all XIP applications. This feature requires the **XIP-3901-UDC-HDR** option. See [Options Panel](#), on page 122 for details about how to activate card options.

In order to use Custom LUTs, you first need to configure the Network tab. See [Network Panel](#), on page 119.

You can Load up to 8 LUTs. For each custom LUT you load, you need to specify input/output colorimetry, input/output range and output transfer characteristics.

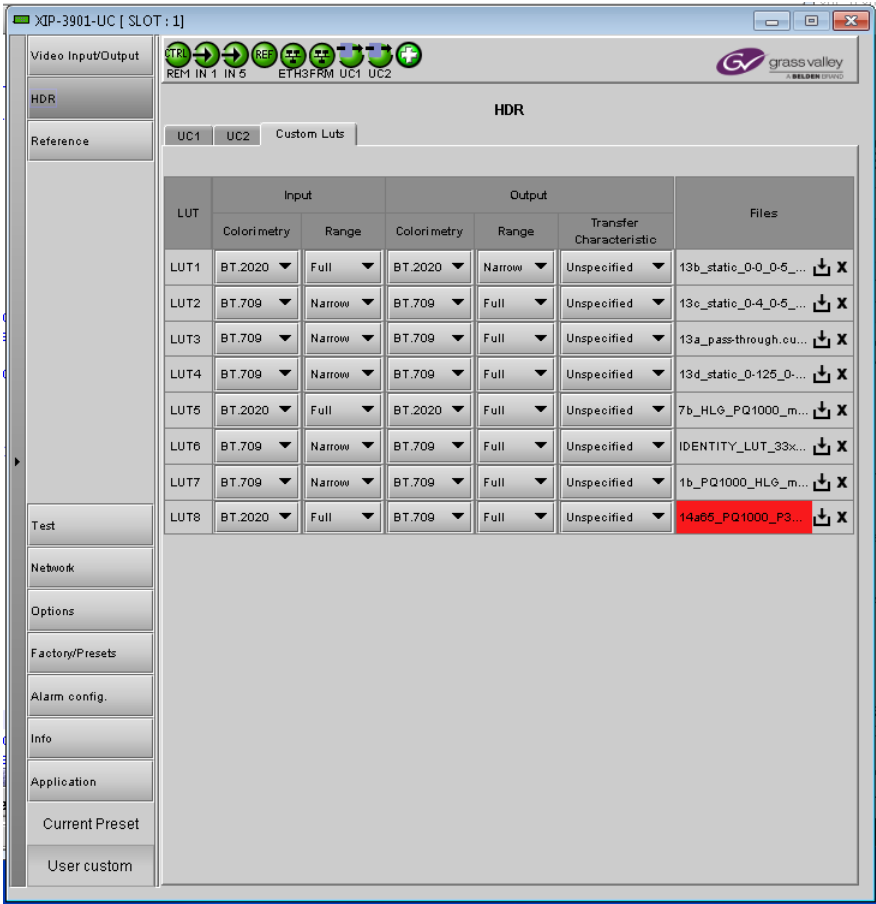

Figure 7-20: Custom LUTs Tab

Property	Custom LUTs Parameters	Available Values / Description
Input	Colorimetry	BT.709, BT.2020
	Input Range	Narrow, Full
Output	Colorimetry	BT.709, BT.2020
	Output Range	Narrow, Full
	Transfer Characteristic	SDR, HLG, PQ, Unspecified
Files	-	Click to upload or replace a LUT file. Click to remove the currently loaded LUT file. The name of the currently loaded LUT file will be partially displayed. Mouse-over the field to display the full name. The background will change to RED if the uploaded file is invalid.

Reference Panel

This panel is used to select the reference to be used by the XIP-3911 or XIP-3901 to synchronize the SDI inputs.



Figure 7-21: Reference Panel (Shown on XIP-3901-UC)

Property	Description
Reference Presence	The icons show the presence and status of the various reference sources. For the external reference, the format is shown in the External Format window. Gray: There is no carrier or the carrier is not valid. Yellow: The carrier is present and is valid but its format is not supported. Green: The carrier is present and is valid and its format is supported.
External Format	Shows the current external reference format. The following shows which reference formats are supported: NTSC: Supported PAL: Supported 1080i 59 Hz: Unsupported 1080i 50 Hz: Unsupported 720p 59 Hz: Unsupported 720p 50 Hz: Unsupported

Property	Description
Selected Reference	<p>Shows which source is selected as a reference for each channel. The icons show whether the channel is locked to its reference or not.</p> <p>Gray: Locked on input, but the reference is not available.</p> <p>Green: Locked.</p> <p>Red: Missing, invalid, unsupported, or the channel is not locked to the selected reference.</p> <p>Note: If the selected reference is missing, invalid or unsupported, the SDI output(s) will be inactive (no carrier).</p>
Reference Source	<p>Use the radio buttons to select from the following settings:</p> <p>Auto (default): This mode selects the first source detected in this order of priority:</p> <ol style="list-style-type: none"> 1 External Reference input 2 URS 3 Input <p>External: Selects the signal connected to the rear panel REF IN connector.</p> <p>URS: Selects the Universal Reference Signal from the Densité frame's backplane.</p> <p>Input: Each path will lock on its SDI input:</p> <ul style="list-style-type: none"> • UC1/DC1/FS1 on the rear panel 12G/3G/HD IN 1 connector. • UC2/DC2/FS2 on the rear panel 12G/3G/HD IN 5 connector. <p>Note: On the XIP-3901-UC, you can enable 3G Output Minimum Delay for a 3G SDI Output in the Timing tab for a channel. On the XIP-3901-FS, you can enable Minimum Delay for a channel with the 12G/3G/HD and Quad Link 3G operation modes. In these cases, the reference source will be forced to Input for the channel (for the XIP-3901-UC, this will only occur if SDI input is 3G). For more information, see Timing Tab, on page 87.</p>
URS Format	<p>Use the radio buttons in the URS Format area to select the URS mode:</p> <p>OFF (default): URS cannot be selected as the reference source and is ignored by the Auto detection mode. URS is grayed out in the Reference Source section of the user interface.</p> <p>URS 29.97 Hz: If Reference Source is set to URS, lock on 29.97 Hz.</p> <p>URS 25 Hz: If Reference Source is set to URS, lock on 25 Hz.</p>

Test Panel

You may activate the Color Bars & Tone test signal for the two channels independently by enabling the appropriate checkboxes.





Figure 7-22: Test Panel (Shown on XIP-3901-UC)

Property	Description
Color Bars & Tone	<p>Enables test signals at the card's output:</p> <ul style="list-style-type: none"> Video: Generate a video test pattern. On HD Video outputs, this will generate a 75% color bar with 75% white. On 3G, Quad Link 3G and 12G Video outputs, test pattern will follow the format setting. In the XIP-3901 UC only, the 75% color bar is inserted as 3G/HD SDI and upconverted to 12G/3G/Quad Link 3G. Audio: Generate a 1 KHz sine wave at -18dBFS on all audio channel outputs: Continuous tone on right channel; pulsed tone on left channel of every pair (250 ms pulse every 3 seconds). Audio inserted on Quad Link 3G - link 1 only. Metadata: blank except for Video Payload ID (Transfer Characteristic, Colorimetry, and Bit depth) on SDI output.

Property	Description
Format	Set video test pattern format for 3G, Quad Link 3G and 12G Video outputs: <ul style="list-style-type: none"> • SDR BT.709 (75%): 75% Color bar with 75% white • HLG BT.2110-0: Test pattern HLG narrow range as per ITU-R BT.2111-0 • PQ Narrow BT.2111-0: Test pattern PQ narrow range as per ITU-R BT.2111-0 • PQ Full BT 2111-0: Test pattern PQ full range as per ITU-R BT.2110-0

Status

When Test mode is activated on a channel, the status icon display for that channel will show the Color Bars&Tone icon.

Test Pattern	Operating Mode	Icon
Enabled	Color Bars&Tone	
Disabled	Process	

Network Panel

The Network panel is used to set the network configuration of the ETH3 Ethernet port on the XIP-3911 or XIP-3901, and the bridged port through the Densité frame controller (FRM). These settings are shared by all UC, DC, and FS applications, since there is only one Ethernet port on the platform.

The ETH3 Ethernet port is used to perform firmware upgrades and to upload HDR Custom LUTs on the XIP-3911 or XIP-3901 only if the card is installed in a Densité 3+FR1 or Densité 3+FR4 frame with a CPUETH3 Basic controller. When the card is installed in a Densité 3+FR4 frame with a CPUETH3 Standard or Advanced controller, the firmware upgrade is performed using the frame controller's Ethernet port and HDR Custom LUTs can be uploaded through the bridged port through the Densité frame controller (FRM).

Configuring the XIP-3901-UC / -DC / -FS Applications with iControl
Network Panel



Figure 7-23: Network Panel (Shown on XIP-3901-UC)

Property	Description
Hostname	Set a unique network identification label by which this device will be known. Only alphanumeric characters and the hyphen are permitted.
Domain Name	Shows the name of the domain(s) the card is part of. At least one interface must be configured with DHCP in order to be able to receive this information.
DNS Servers	Shows the addresses of the name resolution servers. At least one interface must be configured with DHCP in order to be able to receive this information.

Property	Description
Control Port ETH3, Control Port Frame (FRM)	<p>The FRM port is a bridged port through the Densité frame controller. The physical frame controller's Ethernet port must be connected to the network for this interface to work. See Connections and Cabling, on page 63. Note: The FRM port address must not contain any of the frame controller's IP addresses.</p> <p>Control ports can be used for firmware upgrades:</p> <ul style="list-style-type: none"> • If the card is installed in a Densité 3+FR1 or Densité 3+FR4 frame with a CPU-ETH3 Basic controller, the ETH3 port must be used. Note: Before upgrading through the ETH3 port, you will need to configure ETH3 through local menu or install the iControl bundle for the current firmware version in order to configure ETH3. Once ETH3 has been configured, you will be able to upgrade/downgrade the card and its iControl bundle. • If the card is installed in a Densité 3+FR4 frame with a CPU-ETH3 Standard or Advanced controller, the firmware upgrade is performed using the frame controller's Ethernet port (FRM).
Mode	<p>Set the mode to assign an IP address to an Ethernet port.</p> <p>Off: Ethernet port disabled, it will not be used.</p> <p>Auto (DHCP): Ethernet port enabled with automatic configuration using a network's DHCP server.</p> <p>Static: Ethernet port enabled with static user specified configuration (IP Address, Subnet Mask, and Gateway).</p>
IP Address	When Mode is set to Static , set the card's IP address.
Subnet Mask	When Mode is set to Static , set the subnet mask for your network.
Gateway	When Mode is set to Static , set the network switch's IP address.
MAC address	Shows the Ethernet port's MAC Address.
LLDP	Shows the Link Layer Discovery Protocol (LLDP) TLV values. LLDP is used to advertise the identity, capabilities, and neighbors on a LAN. Click Details for any one Ethernet port to view the LLDP TLV values. See Network ETH LLDP Properties , on page 122.
Test Address	Test the IP connectivity to a device (on the same network) from any one Ethernet port for troubleshooting purposes. Enter the device's IP address and click Ping . In Status , a message shows the ping's IP connectivity status.
Apply Cancel	When active, this applies or rejects your current changes. Pending changes are displayed in red.

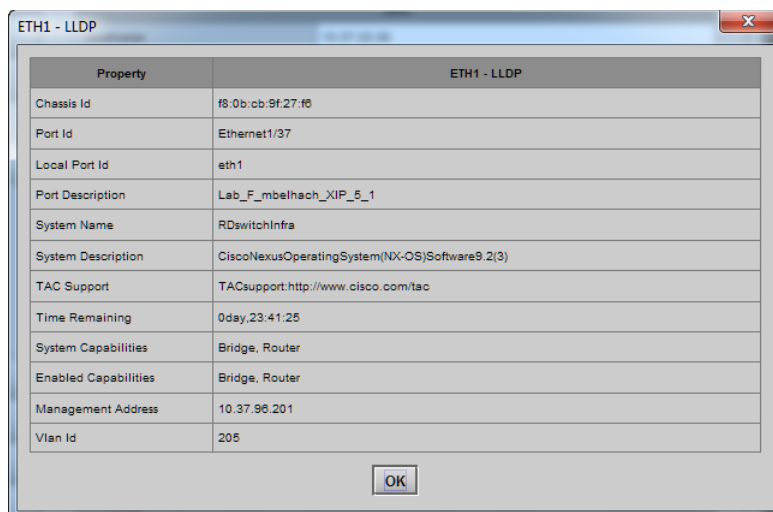

Figure 7-24: Network ETH LLDP Properties

Options Panel

There is one option available for the XIP-3901-UC / -DC / -FS:

- **XIP-3901-UDC-HDR:** Enables the card's HDR conversion function. This option is shared by all applications; for example, when activated on a XIP-3901-UC application, it will also be activated on any XIP-3901-DC and XIP-3901-FS applications. When this option is activated, all HDR conversion settings are available. When it is not activated, only the BT.709 to BT.2020 and BT.2020 to BT.709 settings are available. See also [Optional HDR Processing](#), on page 30.

See [HDR Panel](#), on page 111 to see all settings available with this option.

To activate this option, you must:

- 1 Obtain a license key for the option from Grass Valley.
- 2 Open the Options panel and select the appropriate tab.
- 3 Type the license key in the Enter key box.
- 4 Click **Enable option** to enable the option's features.

Once the option is activated, the status box beneath the Enter key area will show the status as active, with a green background.

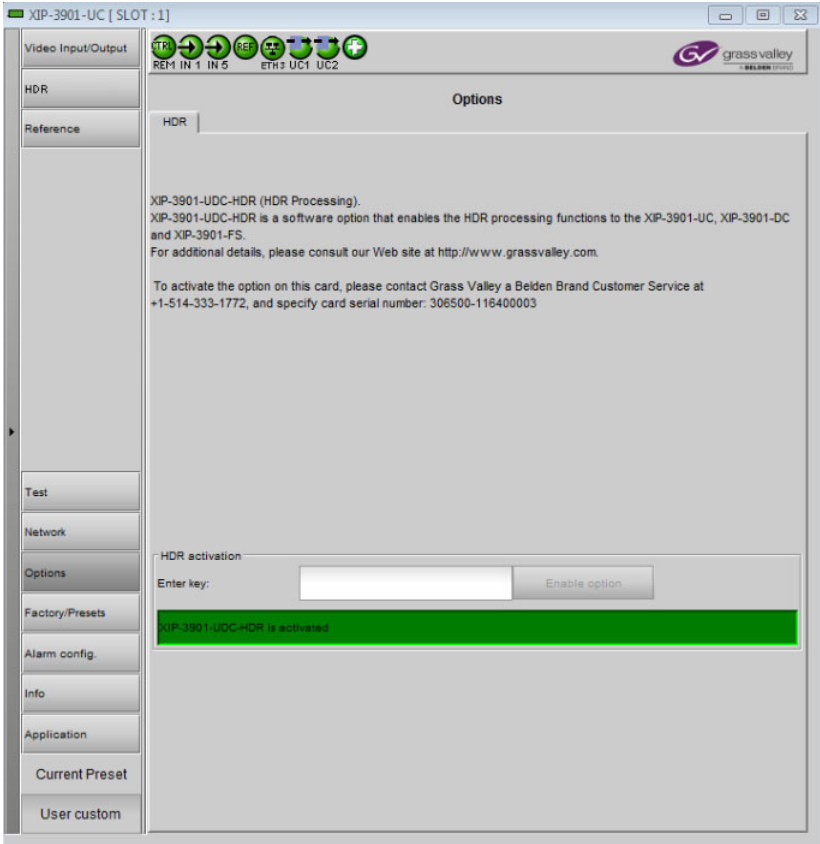

Figure 7-25: Options Panel (Shown on XIP-3901-UC)



Configuring the XIP-3901-UDC-IP v1.2 Application with iControl

XIP-3901-UC, XIP-3901-DC, or XIP-3901-FS	XIP-3901-UDC-IP	XIP-3901-UDC-IF	XIP-3901-GB-IP	XIP-3901-JPEG XS	XIP-3901-ASI
	●				

This section describes the control panels associated with the XIP-3901-UDC-IP application and its use.

Network Panel

The Network panel is used to set the network configuration of the media and control Ethernet ports on the XIP-3901-UDC-IP. ETH1 and ETH2 are media ports and ETH3 and FRM are control (management) ports.

- Media ports manage PTP, video, metadata, and audio streams, as well as NMOS IS-04 and IS-05 also.
- Control ports manage card upgrade as well as NMOS IS-04 and IS-05 also.

Interface Tab

This tab allows you to configure the network settings for media and control ports.

Configuring the XIP-3901-UDC-IP v1.2 Application with iControl
Interface Tab

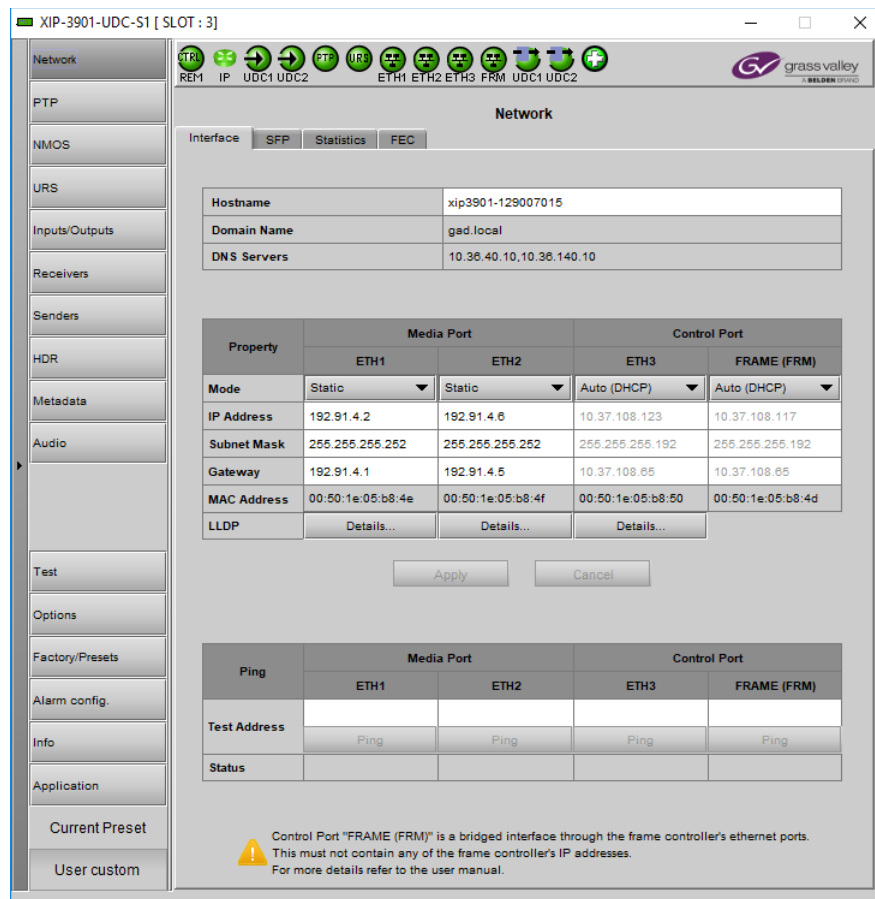

Figure 8-1: Network Interface Tab

Property	Description
Hostname	Set a unique network identification label by which this device will be known. Only alphanumeric characters and the hyphen are permitted.
Domain Name	Shows the name of the domain(s) the card is part of. At least one interface must be configured with DHCP in order to be able to receive this information.
DNS Servers	Shows the addresses of the name resolution servers. At least one interface must be configured with DHCP in order to be able to receive this information.
Media Port ETH1 and ETH2	The media ports support PTP, video, metadata, and audio streams and can be used for NMOS IS-04/IS-05 (see NMOS Panel , on page 133).

Property	Description
Control Port ETH3 Control Port Frame (FRM)	<p>The FRM port is a bridged port through the Densité frame controller. The physical frame controller's Ethernet port must be connected to the network for this interface to work. See Connections and Cabling, on page 63. Note: The FRM port address must not contain any of the frame controller's IP addresses.</p> <p>Control ports can be used for firmware upgrades:</p> <ul style="list-style-type: none"> • If the card is installed in a Densité 3+FR1 or Densité 3+FR4 frame with a CPU-ETH3 Basic controller, the ETH3 port must be used. Note: Before upgrading through the ETH3 port, you will need to configure ETH3 through the frame's local menu or install the iControl bundle for the current firmware version in order to configure ETH3. Once ETH3 has been configured, you will be able to upgrade/downgrade the card and its iControl bundle. • If the card is installed in a Densité 3+FR4 frame with a CPU-ETH3 Standard or Advanced controller, the firmware upgrade is performed using the frame controller's Ethernet port (FRM). <p>Control ports can also be used for NMOS IS-04 and IS-05. If both control ports are enabled and in the same subnet as the NMOS registry, the FRM port will be used.</p>
Mode	<p>Set the mode to assign an IP address to an Ethernet port.</p> <p>Off: Ethernet port disabled, it will not be used.</p> <p>Auto (DHCP): Ethernet port enabled with automatic configuration using a network's DHCP server.</p> <p>Static: Ethernet port enabled with static user specified configuration (IP Address, Subnet Mask, and Gateway).</p>
IP Address	When Mode is set to Static , set the card's IP address.
Subnet Mask	When Mode is set to Static , set the subnet mask for your network.
Gateway	When Mode is set to Static , set the network switch's IP address.
MAC address	Shows the Ethernet port's MAC Address.
LLDP	Shows the Link Layer Discovery Protocol (LLDP) TLV values . LLDP is used to advertise the identity, capabilities, and neighbors on a LAN. Click Details for any one Ethernet port to view the LLDP TLV values . See Network ETH LLDP Properties , on page 122.
Test Address	Test the IP connectivity to a device (on the same network) from any one Ethernet port for troubleshooting purposes. Enter the device's IP address and click Ping . In Status , a message shows the ping's IP connectivity status.
Apply Cancel	When active, this applies or rejects your current changes made in this tab. Pending changes are displayed in red.

SFP Tab

The SFP tab shows the media ports' SFP cartridge status.

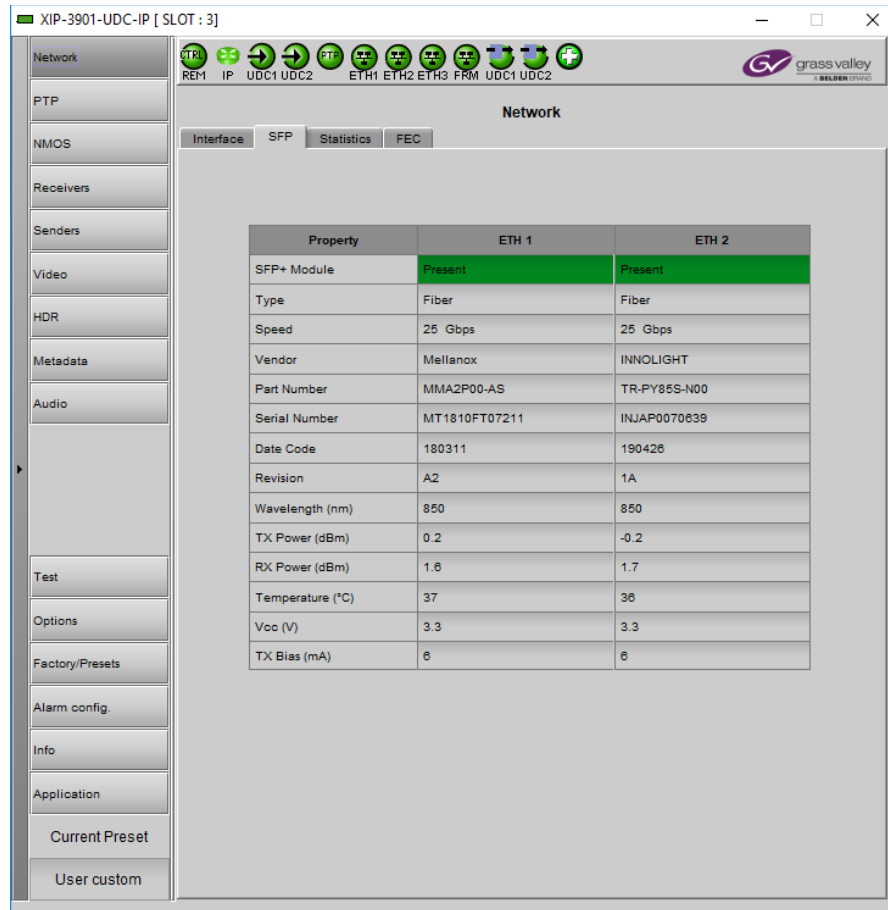

Figure 8-2: Network SFP Tab

Property	Description
SFP+ Module	The current status of the SFP+ module. Green: SFP module detected Grey: SFP mode not detected
Type	The connection media type.
Speed	The connection speed
Vendor	Manufacturer's information about the SFP+ module.
Part Number	
Serial Number	
Datacode	
Revision	

Property	Description
Wavelength	These are values from the SFP's Diagnostic Monitoring Interface (DMI). The background color changes according to the current state: Green: low/high warning flags Red: low/high alarm flags Grey: current state is normal
TX Power	
RX Power	
Temperature	
Vcc	
TX Bias	

Statistics Tab

The Statistics tab shows the data transmission and reception statistics for the media ports. This information can be used to see the level of network utilization and to know if the level of media traffic is at or near the rated network bandwidth. A saturated network will result in packet loss at the receiver.

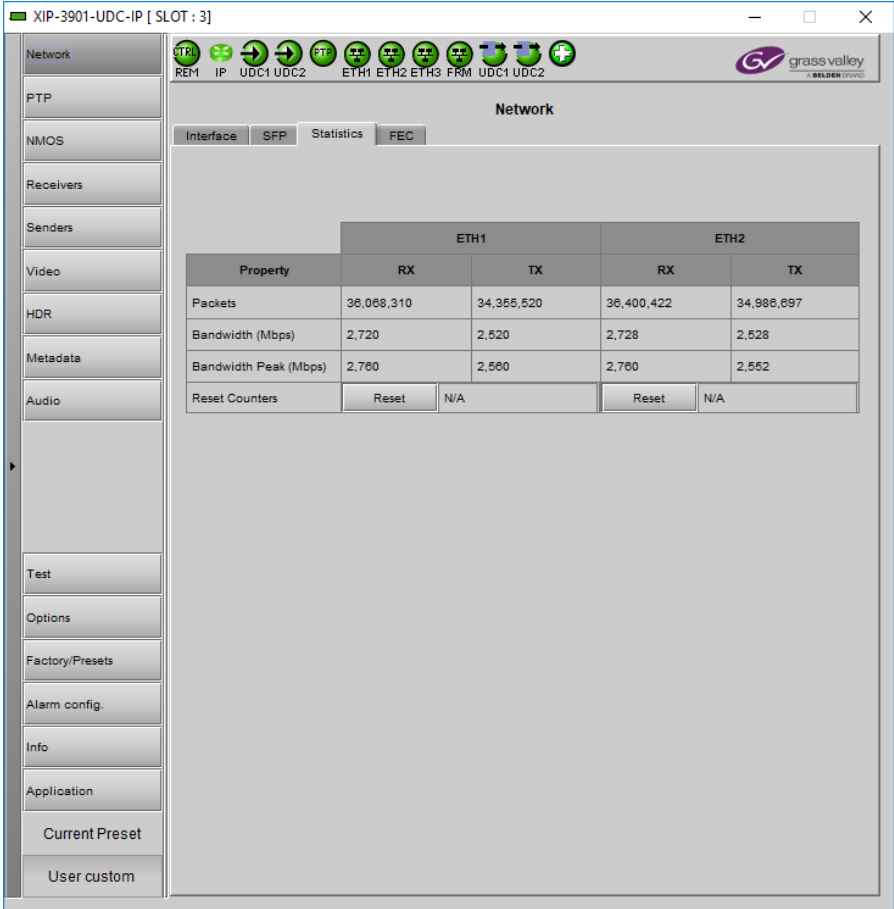

Figure 8-3: Network Statistics Tab

When Reset is clicked, the current date and time is shown as a record of how long the packet counters have been running.

FEC Tab

This tab allows you to configure the media network's error correction scheme for **ETH 1** and **ETH 2**.

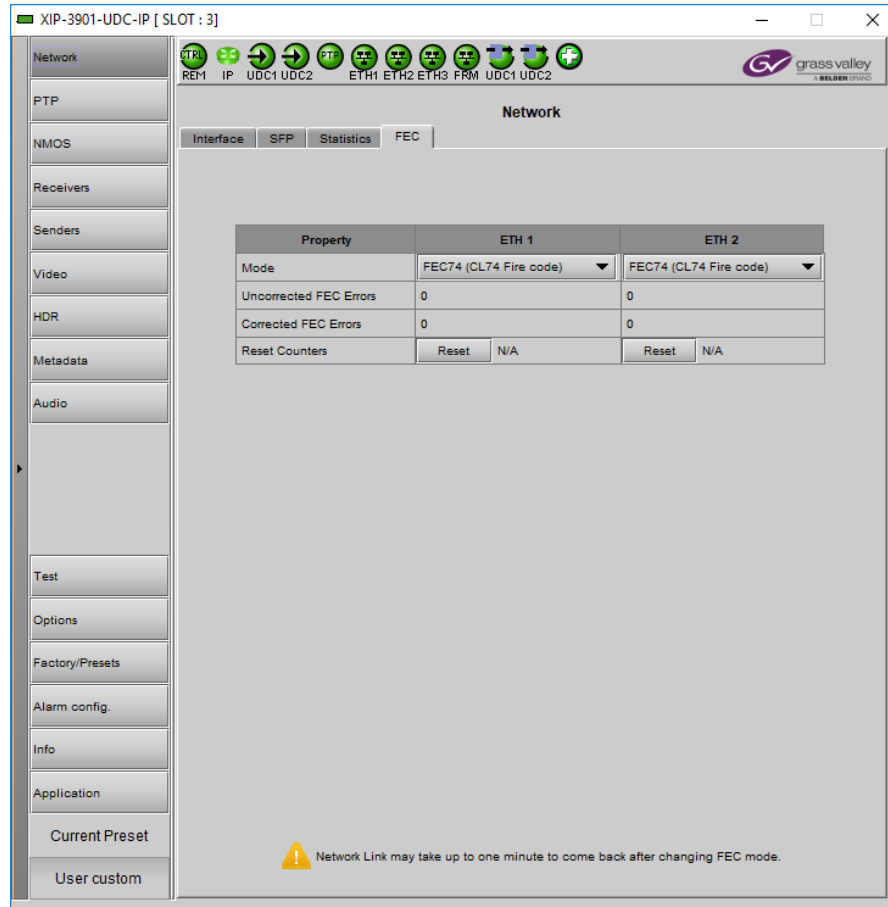

Figure 8-4: Network FEC Tab

Property	Description
Mode	<p>The error correction mode:</p> <ul style="list-style-type: none"> • Off: No error correction is used. • FEC74: Applies IEEE 802.3 Clause 74 Fire Code Forward Error Correction. • FEC108: Applies IEEE 802.3 Clause 108 Reed Solomon Forward Error Correction. <p>Corresponding equipment sending or receiving these media streams must also be configured with the same error correction method. Otherwise the link will fail.</p>
Uncorrected FEC Error Corrected FEC Error	<p>The current number of detected errors at the physical layer.</p> <ul style="list-style-type: none"> • Corrected errors are errors that the FEC algorithm was able to remove. • Uncorrected errors are errors that the FEC algorithm was unable to remove as the bit stream is too damaged. <p>NOTE: The error counters only work when the Mode is set to FEC108 or FEC74.</p>

Property	Description
Reset Counter	Clear the number of errors shown above. When Reset is clicked, the current date and time is shown as a record of how long the corresponding error counter has been running since the last reset.

PTP Panel

To allow vertically accurate video frame synchronization, multicast Precision Timing Protocol (described in IEEE Standard 1588) is used to distribute time across a packet network. It is used on both media ports (ETH1 and ETH2) for BMCA redundancy. This supports Best Master Clock Algorithm (BMCA) as per IEEE-1588-2008. The XIP-3901-UDC-IP supports:

- SMPTE 2059-2 profile; locks the inputs and outputs on PTP
- AES-67 profiles
- Automatic one-step and two-step synchronization mode
- End-to-End Delay mechanism.
- Multicast PTP only

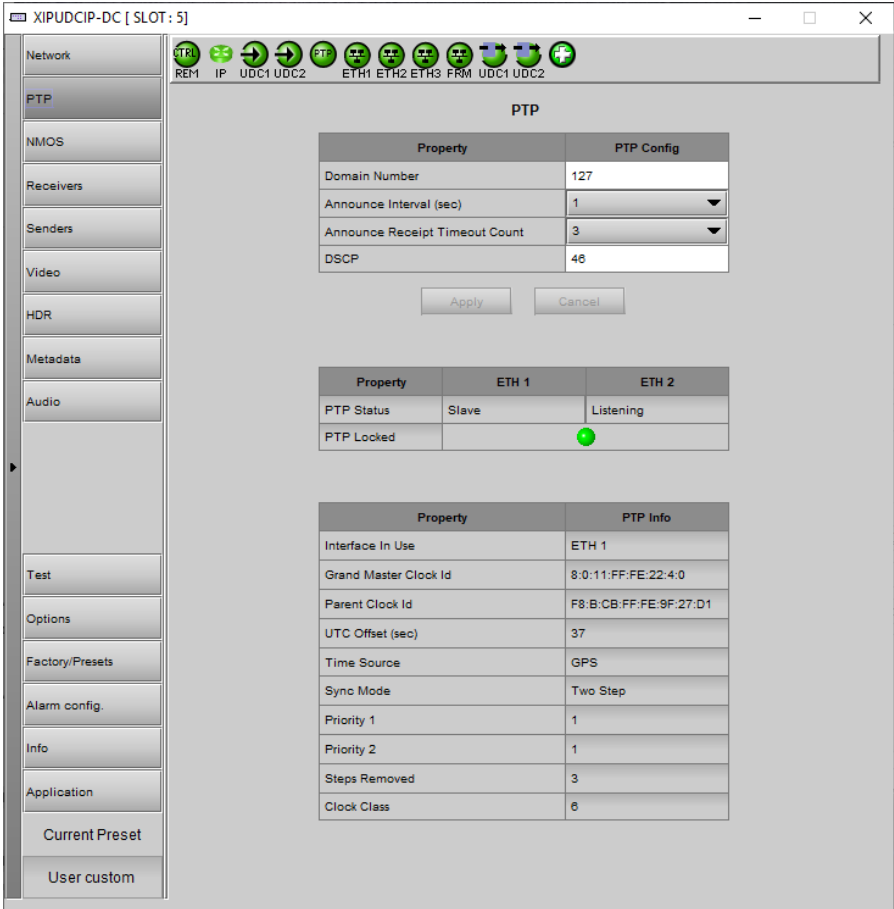

Figure 8-5: PTP Panel

Property	Description
Domain Number	Specify the PTP Domain Number the card is to use to synchronize its clock. A domain is an interacting set of clocks that synchronize to one another using PTP. Clocks are assigned to a domain by virtue of the contents of the Subdomain name or the domain Number (IEEE 1588-2008) fields in PTP messages they receive or generate. The range is 0 to 127. The default value is 127.
Announce Interval	Specify the Announce message interval used by the parent clock (Boundary clock). Announce Interval range is: 0.125, 0.250, 0.500, 1, 2, 4, 8, 16 seconds. The default value is 0.125 second.
Announce Receipt Timeout Count	Specify the Announce Receipt Timeout used by the parent Boundary clock. The Announce Receipt Timeout range is 2 to 10 seconds. The default value is 3 seconds.
DSCP	Sets the quality of service priority for outgoing PTP packets. The range is 0 to 63. The default value is 46.
PTP Status ETH1 & ETH2	Shows the status of the ETH interfaces. The possible values are: Faulty: The protocol's fault state. Listening: The port is waiting for the announceReceiptTimeout to expire or to receive an Announce message from a master. Uncalibrated: One or more master ports have been detected in the domain. Slave: The port is synchronized to the selected master port.
PTP Locked	Shows the card's current overall PTP lock status to the network's Grandmaster clock. Green: The card has successfully locked to the network's PTP Grandmaster clock. Red: The card is not locked to the network's PTP Grandmaster clock.
Interface In Use	Shows the interface that is currently receiving PTP (ETH1, ETH2).
Grand Master ID	Shows the Grand Master's ID (for example, Tektronix).
Parent Master ID	Shows the Boundary clock's ID (Switch ID).
UTC Offset (sec)	Shows the current time offset between UTC and PTP. This value can change. The possible range is -32768 to 32767.
Time Source	Shows the source of time used by the grandmaster clock. The possible values are Atomic Clock, GPS, Terrestrial Radio, PTP, NTP, Hand Set, Other, Internal Oscillator.
Sync mode	Shows the Sync Mode from the Grand Master. A boundary clock cannot have a different setting. The possible values are One Step, Two Step.
Priority 1	Shows the first priority. This is used in the execution of the Best Master Clock Algorithm (BCMA). The Priority (1 or 2) with the lowest value will be used as the clock reference. The possible values are 0 to 255.
Priority 2	Shows the second priority. This is used in the execution of the Best Master Clock Algorithm (BCMA). The possible values are 0 to 255.

Property	Description
Step Removed	Shows how many hops the card is from the Grandmaster. This is used by the Best Master Clock Algorithm (BCMA). The possible values are 0 to 65535.
Clock Class	Shows the clockClass attribute of an ordinary or boundary clock. This denotes the traceability of the time or frequency distributed by the grandmaster clock. The possible values are 0 to 255. For example, 6 = GPS, 99 = free run.

NMOS Panel

XIP-3901-UDC-IP supports Networked Media Open Specifications (NMOS) AMWA IS-04 for device discovery and registration and IS-05 for connection management. Furthermore, it supports AMWA BCP-002 recommendations for Grouping NMOS Resources.

XIP-3901-UDC-IP relies on an external NMOS registry that is used to register NMOS devices. You must point XIP-3901-UDC-IP to this external NMOS registry.

PREREQUISITE: A working NMOS registry service must be available on the network.

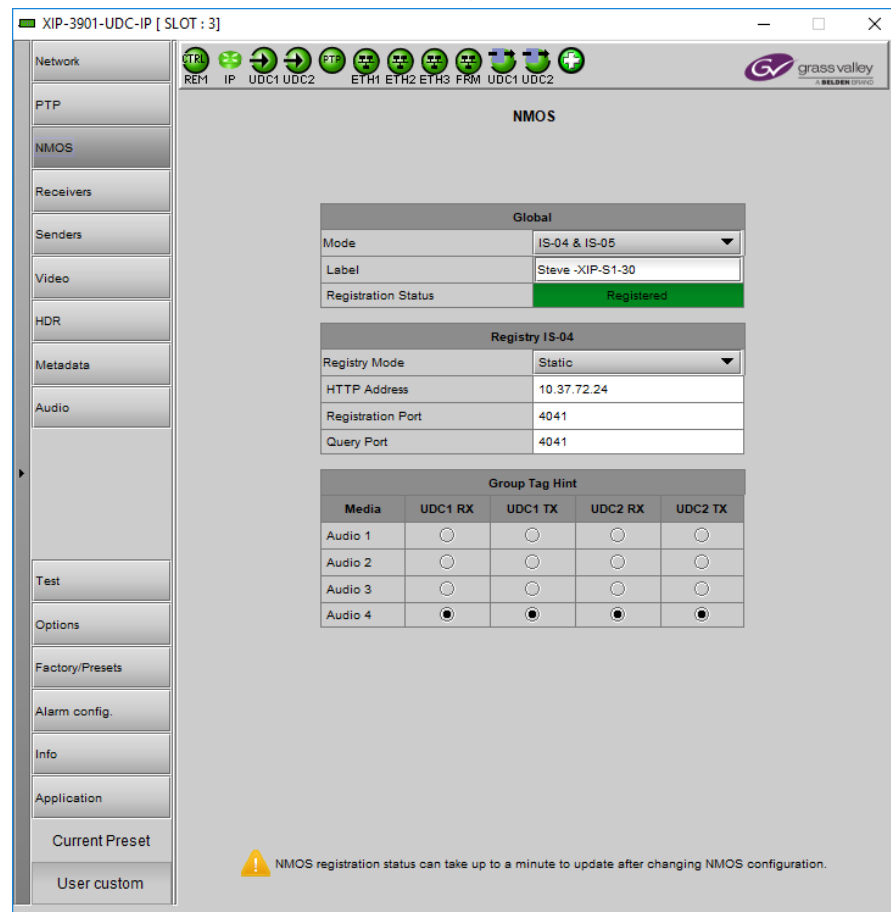

Figure 8-6: NMOS Panel

Property	Description
Mode	<p>Set the NMOS mode:</p> <p>IS-04: enable the Networked Media Open Specifications (NMOS) IS-04 v1.2 or higher for device discovery and registration. All senders will publish and update SDP file, but receivers can't be updated.</p> <p>IS-04 & IS-05: enable the NMOS IS-04 for device discovery and registration and IS-05 for connection management. All senders will publish and update an SDP File and receivers will accept routing request and process the received SDP file.</p> <p>OFF: disable NMOS. This eliminates the RED status when NMOS IS-04 is not used. This is the default.</p>
Label	Set the identifier by which this XIP-3901-UDC-IP card will be known in the NMOS registry, and by extension, to other NMOS devices using this NMOS registry.
Registration Status	<p>Shows if the card has successfully registered itself in the NMOS registry.</p> <p>Green: the card has successfully registered itself with the NMOS registry.</p> <p>Red: the card is not yet registered with the NMOS registry.</p> <p>Grey: NMOS is disabled (Mode is OFF).</p>
Registry IS-04, Registry Mode	<p>Set the IS-04, Registry Mode:</p> <p>Auto: automatic discovery of the NMOS registry using DNS Service Discovery (DNS-SD), as described in AMWA IS-04 NMOS Discovery and Registration Specification v1.2.</p> <p>Static: manually specified NMOS registry values for address, registration port and query port. In this mode, by specifying a registry address in the same subnet as one of the interfaces, the interface will be used. However, when specifying an address in a different subnet, the first available interface will be used in the following order: FRM, ETH3, ETH1, and then ETH2.</p> <p>The default Registry Port value is 3210. The default Query Port value is 3211.</p>
HTTP Address	Set the NMOS registry's IP Address when the Registry IS-04, Registry Mode is Static.
Registration Port	Set the NMOS registry's registration port number when the Registry IS-04, Registry Mode is Static.
Query Port	Set the NMOS registry's query port number when the Registry IS-04, Registry Mode is Static.
Group Tag Hint	Set which audio receiver/sender to include in the Group Hint Tag. By Default GV Convergent creates logical source/destination groups with only one audio stream. If you want to have more audio receivers in a source/destination group, you will have to create them manually in GV Convergent.

Receivers Panel

The Receivers panel has two tabs (**UDC1** and **UDC2**); one for each of XIP-3901-UDC-IP's independent processing channels. The configuration of the **UDC2** tab is the same as the **UDC1** tab. Only the configuration of the **UDC1** tab is shown below.

Config Tab

This tab allows you to configure the expected source media’s audio channels, stream address, port, and IGMPv3 source. The receivers are SMPTE ST 2110-20 (Video1), ST 2110-40 (Meta 1), and ST 2110-30 (Audio 1, Audio 2, Audio 3, and Audio 4).

Statuses confirm that the RTP stream is successfully streaming.

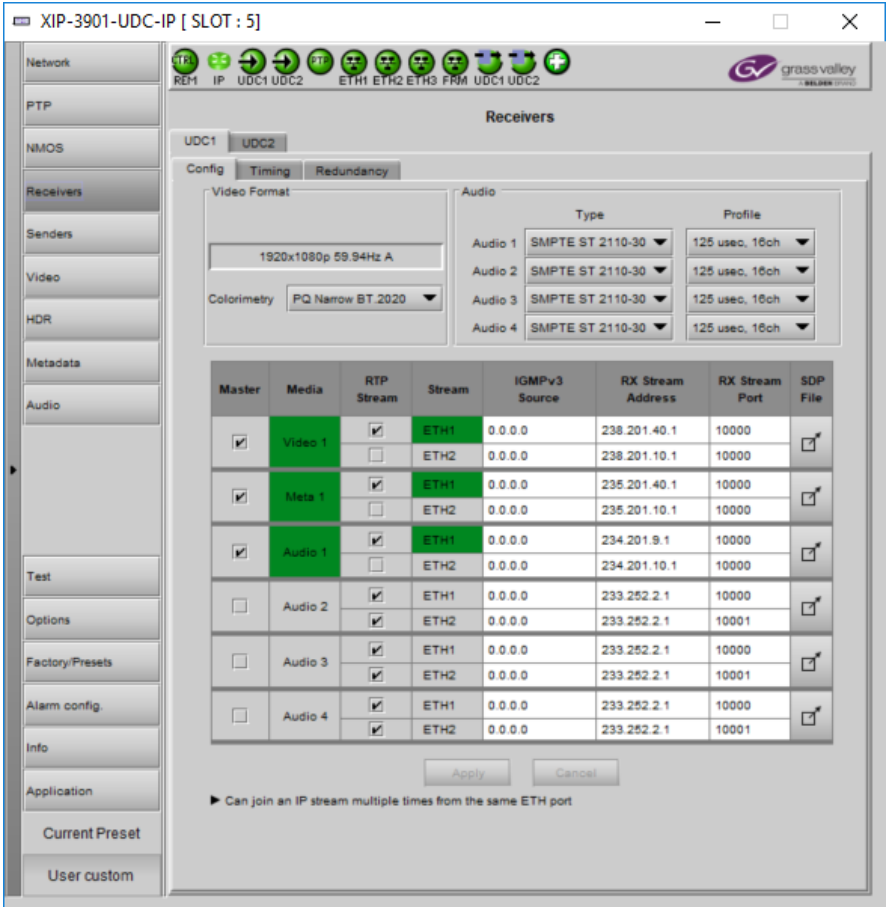

Figure 8-7: Receivers Config Tab

Property	Description
Video Format	Shows the video source stream’s format (resolution / frame rate).
Colorimetry	Shows the colorimetry and Transfer Characteristics System (TCS) information extracted from the associated SDP file for the selected SMPTE 2110 stream allowing for a constant update between a sender and a receiver. In the absence of valid SDP contents, use the dropdown list to manually set the stream colorimetry type.

Property	Description
Audio	<p>Type: Use the pull-down to set the audio source stream's type for streams Audio 1 to Audio 4.</p> <ul style="list-style-type: none"> • Type SMPTE ST 2110-30: for PCM linear audio (AES67 compatible) • Type SMPTE ST 2110-31: for transparent transport of non-linear audio and data formats: provides bit-transparent AES3 over IP <p>Profile: Use the pull-down to set the audio profile for streams Audio 1 to Audio 4. Audio receivers support Level C as per SMPTE 2110-30/31: 48kHz stream from 1 to 8 channels (1 to 4 for SMPTE 2110-31) at packet times of 1ms and 1 to 64 channels (1 to 60 for SMPTE 2110-31) at packet time of 125us.</p> <p>These settings can also be managed by external NMOS control. See NMOS Panel, on page 133.</p>
Master	<p>Set to enable a media receiver. This manages the Join/Release of both the primary and secondary streams.</p> <p>These settings can also be managed by external NMOS control. See NMOS Panel, on page 133.</p>
Media	<p>Shows the stream type. The background shows the current media status:</p> <p>Green: no error Red: error Grey: inactive</p>
RTP Stream	<p>Set to enable each stream receiver individually (primary and secondary).</p>
Stream	<p>Shows the primary (ETH1) and secondary (ETH2) stream receiver status:</p> <p>Green: no error Red: error Grey: inactive</p>
IGMPv3 Source	<p>Set the source from which to receive multicast streams. With this protocol, the card deals with a switch to subscribe to one or many streams that are coming from different sources. Both iGMPv3 and iGMPv2 protocols are supported. Set this to 0.0.0.0 if iGMP source is not used. The source range is 0.0.0.0 to 255.255.255.255. The default value is 0.0.0.0.</p> <p>These settings can also be managed by external NMOS control. See NMOS Panel, on page 133.</p>
RX Stream Address	<p>Set the IP address and UDP port number at which this card receives a specific stream. IP address 0.0.0.0 disables a receiver. The default UDP port values are: 10000 for all media receivers.</p>
RX Stream Port	<p>These settings can also be managed by external NMOS control. See NMOS Panel, on page 133.</p>
SDP File	<p>Click to show the last SDP file received through NMOS IS-05 since the last bootup. This window does not refresh automatically; you need to close and re-open the window to see an update. If the card has never received an SDP file since last its last bootup, the window will be empty.</p>
Apply Cancel	<p>When active, this applies or rejects your current changes made in this tab except for Audio type and Profile</p>

Timing Tab

This tab allows you to view the network health of the stream's connection (link latency, receiver buffer level, and offset time).

The screenshot displays the 'Receivers' configuration window for 'XIP-3901-UDC-IP [SLOT : 5]'. The 'Timing' tab is selected, showing a table of receiver statistics. The table has columns for Media, Stream, Link Latency (usec), Buffer Level (usec and %), and Link Offset (usec). Below the table is a 'Property Value' section with settings for Network Tolerance, Audio Mode, and Synchronized Audio.

Media	Stream	Link Latency (usec)	Buffer Level		Link Offset (usec)
			(usec)	(%)	
Video 1	ETH1	620	7246	11.83	7626
	ETH2	0	0	0.00	0
Meta 1	ETH1	122	0	0.09	122
	ETH2	0	0	0.00	0
Audio 1	ETH1	125	7250	2.83	7637
	ETH2	0	0	0.00	0
Audio 2	ETH1	0	0	0.00	0
	ETH2	0	0	0.00	0
Audio 3	ETH1	0	0	0.00	0
	ETH2	0	0	0.00	0
Audio 4	ETH1	0	0	0.00	0
	ETH2	0	0	0.00	0

Property	Value
Network Tolerance	10
Audio Mode	Video Group Sync
Synchronized Audio 1	<input type="checkbox"/>
Synchronized Audio 2	<input type="checkbox"/>
Synchronized Audio 3	<input type="checkbox"/>
Synchronized Audio 4	<input type="checkbox"/>

Figure 8-8: Receivers Timing Tab

Property	Description
Media	Shows the stream type. The background shows the current media status: Green: No error Red: Error Grey: Inactive
Stream	Shows the primary (ETH1) and secondary (ETH2) stream receiver status: Green: No error Red: Error Grey: Inactive
Link Latency	Shows the time it takes for a packet to come from the source to the receiver. This measurement represents the difference between incoming RTP timestamp and PTP time before the receiver's buffer.

Property	Description
Buffer level	Shows the amount of preloaded data stored in the receiver that is ready for use in microseconds and in percentage. The current buffer level in microseconds shows the minimum latency required to receive a continuous stream. The current buffer level in percentage shows how much of the internal buffering is used to receive the current stream.
Link Offset	Shows the resulting link latency after being read out from receiver's buffer. This measurement is the difference between the packet RTP timestamp and the PTP time after the receiver's buffer and represents the total reception delay. Video, Metadata, and audio link offset depends on the selected Network Tolerance. Moreover, Audio link offset can also depend on the currently-selected Audio Mode.
Network Tolerance	Network Tolerance is directly related to the current operating level of the video receiver's buffer. That is, the bigger the value, the greater the buffer usage will be. Additional latency is then introduced as a result, thus giving a better tolerance to packet distribution and network jitter. SMPTE ST 2022-7 Class A, wide source or software-based sources can then be received without errors. To optimize this parameter, start with the smallest Network Tolerance and increase it until video, metadata, and audio streams statuses become GREEN. NOTE: Metadata streams are automatically synchronized to the video. Incoming metadata streams should not be delayed by more than one frame with respect to the video to be properly synchronized. If the metadata stream is delayed by more than one frame, then it is going to be delayed by one frame. Use the Link Offset measurement to monitor this condition.
Audio Mode	Video Group Sync: Audio is synchronized with the video stream. You might have to add more Network Tolerance until the audio Receiver Stream Statuses are GREEN in order to be able to receive audio streams that are delayed. Audio streams are synchronized to the video based on the RTP Timestamp. Audio Group Sync: Audio reception is done without regard to video synchronization. Audio buffer level is set automatically based on incoming Link Latency measures of all audio streams. A common link offset value will be selected based on the highest received link latency (except those in synchronized mode). It will keep the worst measured link latency since a stream was enabled, after a PTP disturbance or bootup. To force a recalculation of the link offset, disable/enable one of your received streams.
Syntonized Audio 1 to 4	Set to ignore Audio RTP timestamps. Audio buffer reception is then fixed to 25%. Use these settings to manage audio streams that are not properly time stamped. Enable syntonize for audio 1 to 4 individually.

Redundancy Tab

This tab allows you to view the reception state regarding SMPTE ST 2022-7 redundancy. The primary and secondary streams, at the packet level, will work together in order to produce a valid resulting stream. To achieve redundancy, both streams need to be in range with respect to the receiver buffer. Adjustments can be done by applying a bigger Network Tolerance if need be (see [Timing Tab](#), on page 137). In the circumstance in which only one stream is successfully received, the resulting stream will be valid as well but without any active redundancy protection.



Figure 8-9: Receivers Redundancy Tab

Property	Description
Media	The background shows the current media status: Green: No error Red: Error Grey: Inactive
Stream	Shows the primary (ETH1) and secondary (ETH2) stream receiver status: Green: No error Red: Error Grey: Inactive
Error	Shows the number of packets in error that will required SMPTE 2022-7 reconstruction for each Ethernet port.
Reconstruction Error	Shows if the redundant stream was successful at maintaining signal integrity for the previous 5 seconds, when primary (ETH1) and secondary (ETH2) ports are enabled.
Reset Counters	Clears the number of errors shown above. When Reset is clicked, the current date and time is shown as a record of how long the error counters have been running since the last reset.

Senders Panel

The Senders panel has three tabs (**UDC1**, **UDC2**, and **Advanced**); **UDC1** and **UDC2** are for each of XIP-3901-UDC-IP's independent processing UHD channels. The **Advanced** tab allows you to configure the outgoing payload type and DSCP priority.

The XIP-3901-UDC-IP provides an additional HD output for monitoring purposes of the first processing path's video (**UDC1**) when the secondary processing path **UDC2** is also configured to provide an HD Output. While the maximum output bandwidth is 25 Gbps, certain stream format combinations can oversubscribe the card's output bandwidth.

Table 1 – Selecting the resolution and number of video streams to remain within the XIP-3901-UDC-IP's output network bandwidth capacity

Video Output Stream	Required Network Bandwidth
UDC1: Video 1	UHD: 12 Gbps HD: 3 Gbps Disabled: 0 Gbps
UDC2: Video 2 (Monitoring)	HD: 3 Gbps Disabled: 0 Gbps
UDC2: Video 1	UHD: 12 Gbps HD: 3 Gbps Disabled: 0 Gbps

Output stream formats must be chosen in the **UDC1** and **UDC2** tabs such that the total effective bandwidth of the combined video streams is 24 Gbps or less, as bandwidth must be set aside for audio and ancillary (**Meta**) stream bandwidth also. Streams can be disabled by deselecting **Master** for the corresponding stream (see below).

When the XIP-3901-UDC-IP's maximum output bandwidth is oversubscribed (total streams require more than the available 25 Gbps bandwidth), the symptoms are that of packet loss: missing blocks of video, audio dropout, and random loss of ancillary data on both processing channels.

UDC1 Tabs

This tab allows you to configure the destination media's video format, audio channels, and the SMPTE ST 2110 output stream's IP addresses and port numbers for the first processing channel (**UDC1**).

The **UDC1** processing channel can:

- Send up to two SMPTE 2110-20 video streams (**Video 1** and **Video 2**).
 - **Video 1** is the main up / down conversion video stream.
 - **Video 2 (Monitoring)** is an additional HD Monitoring output. For example, when a lower bandwidth video monitoring output feed is required for equipment that cannot directly make use of a 4K UHD video stream being sent by **Video 1**. **Video 2 (Monitoring)** is optionally available:
On the **UDC1** processing channel only.

When **Video** in the **UDC2** processing channel has also been configured to provide an HD output video stream format.

See [Table 1 – Selecting the resolution and number of video streams to remain within the XIP-3901-UDC-IP’s output network bandwidth capacity](#), on page 140 for more information.

- Send full ancillary space on one SMPTE 2110-40 metadata stream (**Meta 1**)
- Send 4 audio streams (**Audio 1 to Audio 4**)
 - **Audio 1** can send up to 64 processed audio channels.
 - **Audio 2 to Audio 4** can send up to 64 audio channels, but only audio channels 1 to 16 are processed audio channels. Audio channels 17 to 64 will contain silence.

Statuses confirm that the RTP stream is successfully streaming.

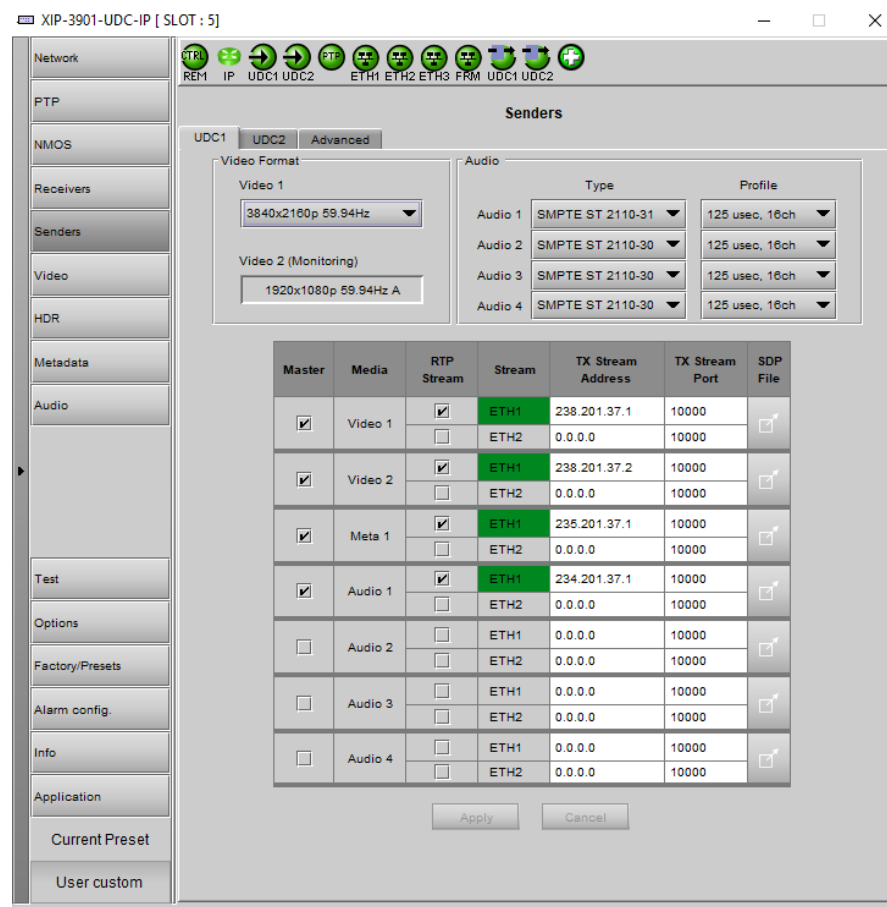

Figure 8-10: Senders UDC1 Tab

Property	Description
Video Format	<p>Video 1: Use the pull-down to set the video format for the destination (resolution / frame rate).</p> <p>Video 2 (Monitoring): Shows the video format of the secondary monitoring stream that is derived by the UDC1 processing channel and is typically used for monitoring applications.</p> <ul style="list-style-type: none"> • When UDC1 Video 1 main output is configured to provide an HD video format, Video 2 (Monitoring) output is of the same quality as the UDC1 Video 1 output. • When UDC1 Video 1 main output is configured to provide a UHD video format, Video 2 (Monitoring) output is one of the internal 2SI links (HD video output rate). • Video 2 (Monitoring) is meaningful for a card topology when Video 1 in the UDC2 processing channel has been configured to provide an HD output. • In the scenario that UDC1 and UDC2 processing channels are both configured to provide a UHD outputs, then Video 2 (Monitoring) should not be deployed: in this case deselect Master to disable Video 2 (Monitoring) output. <p>See Table 1 – Selecting the resolution and number of video streams to remain within the XIP-3901-UDC-IP’s output network bandwidth capacity, on page 140 for more information.</p>
Audio	<p>Type: Use the pull-down to set the audio stream’s type for streams Audio 1 to Audio 4.</p> <ul style="list-style-type: none"> • Type SMPTE ST 2110-30: for PCM linear audio (AES67 compatible) • Type SMPTE ST 2110-31: for transparent transport of non-linear audio and data formats. Provides bit-transparent AES3 over IP. <p>Profile: Use the pull-down to set audio profile for streams Audio 1 to Audio 4. Audio senders support Level C as per SMPTE 2110-30/31: 48kHz stream from 1 to 8 channels (1 to 4 for SMPTE 2110-31) at packet times of 1ms and 1 to 64 channels (1 to 60 for SMPTE 2110-31) at packet time of 125us.</p> <p>For Audio 2 to Audio 4, only the first 16 channels will carry active audio and channels 17-64 will carry silence.</p> <p>These settings can also be managed by external NMOS control. See NMOS Panel, on page 133.</p>
Master	Set to enable a media sender. This manages both the primary and secondary streams. This can also be managed by external NMOS control. See NMOS Panel , on page 133.
Media	Shows the stream type.
RTP Stream	Set to enable a media stream sender for primary and secondary. This can also be managed by external NMOS control. See NMOS Panel , on page 133.
Stream	Shows the primary (ETH1) and secondary (ETH2) streaming status: Green: streaming Red: not streaming Grey: not active
TX Stream Address	Set the IP address and UDP port number of the outgoing stream. IP address 0.0.0.0 disables a sender. The default UDP port values are 10000.
TX Stream Port	Address & UDP port can also be managed by external NMOS control. See NMOS Panel , on page 133.

Property	Description
SDP File	Click to show the last SDP file transmitted through NMOS since the last bootup. This window does not refresh automatically; you need to close and re-open the window to see an update. If the card has never received an SDP file since its last bootup, the window will be empty.
Apply Cancel	When active, this applies or rejects your current changes made in this tab except for Audio Type and Audio Profile

UDC2 Tab

This tab allows you to configure the destination media's video format, audio channels, and the SMPTE ST 2110 output stream's IP addresses and port numbers for the second processing channel (**UDC2**).

The **UDC2** processing channel can:

- Send a single up / down conversion SMPTE 2110-20 video stream (**Video**). When **Video** in the **UDC2** processing channel has been configured to provide an HD output video stream format, it allows you to use the optional HD Monitoring output available on the **UDC1** processing channel (**Video 2 (Monitoring)**). See [Table 1 – Selecting the resolution and number of video streams to remain within the XIP-3901-UDC-IP's output network bandwidth capacity](#), on page 140 for more information.
- Send full ancillary space on one SMPTE 2110-40 metadata stream (**Meta 1**)
- Send 4 audio streams (**Audio 1 to Audio 4**)
 - Audio 1 can send up to 64 processed audio channels.
 - Audio 2 to 4 can send up to 64 audio channels, but only audio channels 1 to 16 are processed audio channels. Audio channels 17 to 64 will contain silence.

Statuses confirm that the RTP stream is successfully streaming.

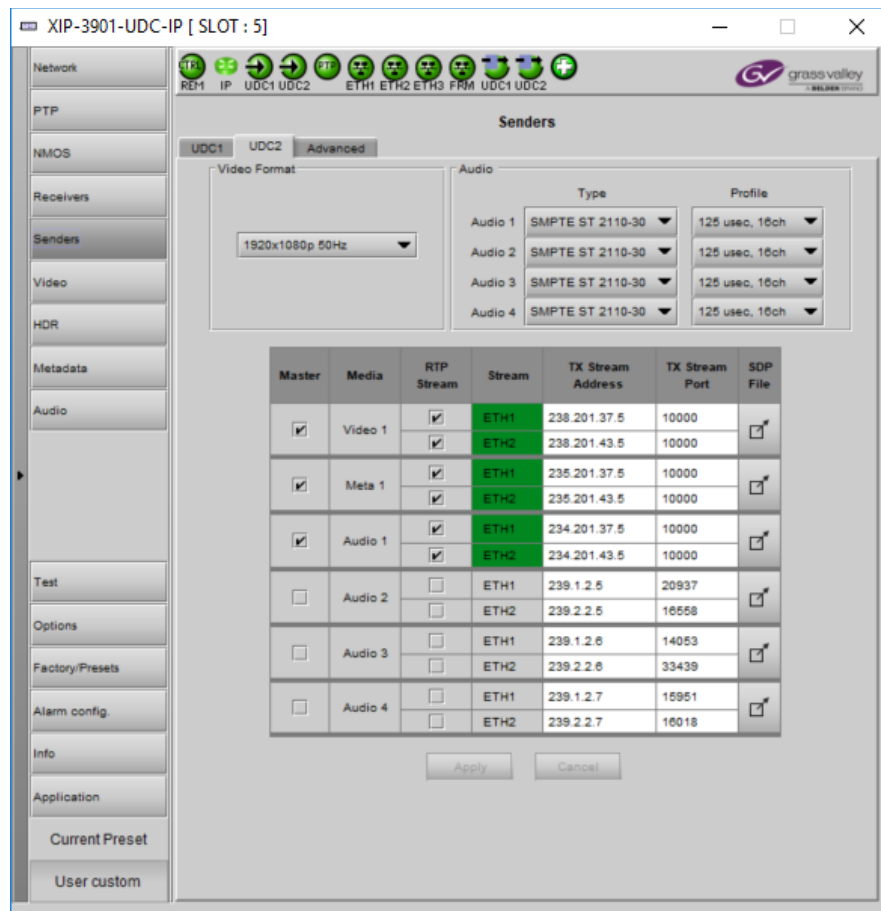

Figure 8-11: Senders UDC2 Tab

Property	Description
Video Format	Use the pull-down to set the video format for the destination (resolution / frame rate). See Table 1 – Selecting the resolution and number of video streams to remain within the XIP-3901-UDC-IP’s output network bandwidth capacity , on page 140 for more information.
Audio	<p>Type: Use the pull-down to set the audio stream’s type for streams Audio 1 to Audio 4.</p> <ul style="list-style-type: none"> • Type SMPTE ST 2110-30: for PCM linear audio (AES67 compatible) • Type SMPTE ST 2110-31: for transparent transport of non-linear audio and data formats. Provides bit-transparent AES3 over IP. <p>Profile: Use the pull-down to set audio profile for streams Audio 1 to Audio 4. Audio senders support Level C as per SMPTE 2110-30/31: 48kHz stream from 1 to 8 channels (1 to 4 for SMPTE 2110-31) at packet times of 1ms and 1 to 64 channels (1 to 60 for SMPTE 2110-31) at packet time of 125us.</p> <p>For Audio 2 to Audio 4, only the first 16 channels will carry active audio and channels 17-64 will carry silence.</p> <p>These settings can also be managed by external NMOS control. See NMOS Panel, on page 133.</p>

Property	Description
Master	Set to enable a media sender. This manages both the primary and secondary streams. This can also be managed by external NMOS control. See NMOS Panel , on page 133.
Media	Shows the stream type.
RTP Stream	Set to enable a media stream sender for primary and secondary. This can also be managed by external NMOS control. See NMOS Panel , on page 133.
Stream	Shows the primary (ETH1) and secondary (ETH2) streaming status: Green: streaming Red: not streaming Grey: not active
TX Stream Address	Set the IP address and UDP port number of the outgoing stream. IP address 0.0.0.0 disables a sender. The default UDP port values are 10000.
TX Stream Port	Address & UDP port can also be managed by external NMOS control. See NMOS Panel , on page 133.
SDP File	Click to show the last SDP file transmitted through NMOS since the last bootup. This window does not refresh automatically; you need to close and re-open the window to see an update. If the card has never received an SDP file since its last bootup, the window will be empty.
Apply Cancel	When active, this applies or rejects your current changes made in this tab except for Audio Type and Audio Profile

Advanced Tab

This tab allows you to configure the outgoing payload type and DSCP priority for SMPTE 2110-20 (UDC video streams: **Video**, **Video 1**, and **Video 2 (Monitoring)**), SMPTE 2110-40 (**Meta 1**) and SMPTE 2110-30/31 (**Audio 1** to **Audio 4**). These setting apply to both **UDC1** and **UDC2** tabs.

Configuring the XIP-3901-UDC-IP v1.2 Application with iControl
Advanced Tab

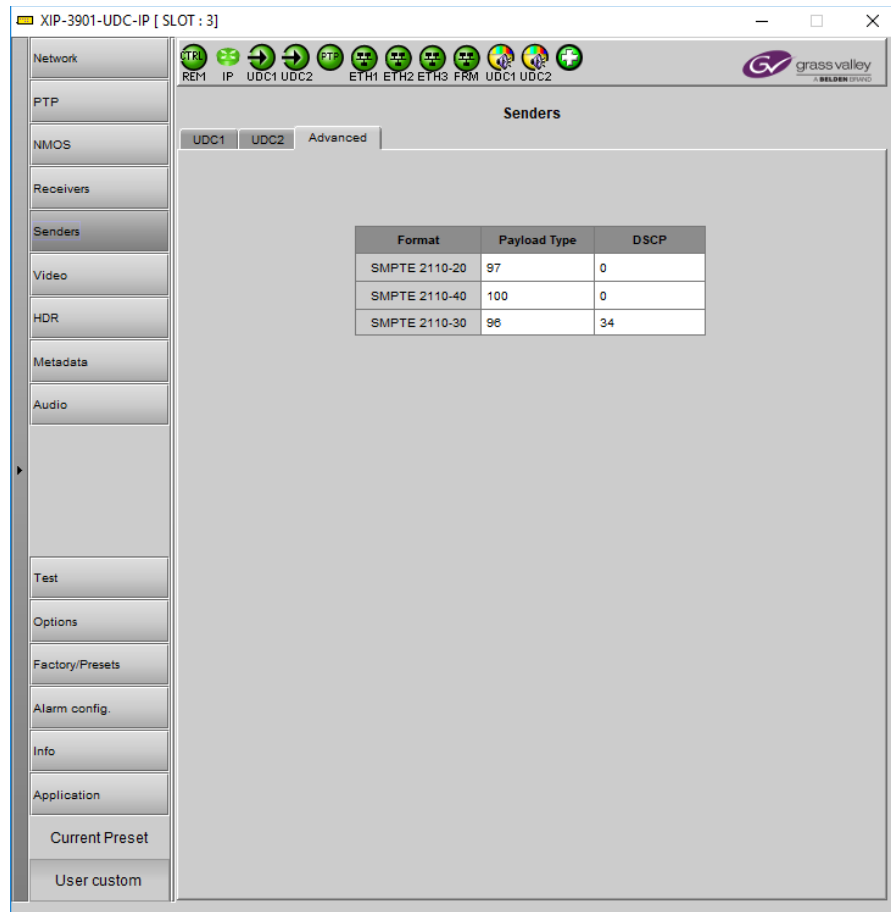

Figure 8-12: Senders Advanced Tab

Property	Description
Payload Type	Sets the RTP Payload ID value of outgoing video, metadata and audio streams. Possible range: 0 to 128 The default value are: <ul style="list-style-type: none"> • 97 for SMPTE 2110-20 (Video) • 100 for SMPTE 2110-40 (Metadata) • 96 for SMPTE 2110-30 (audio)
DSCP	Sets the quality of service priority on the network for the outgoing video, metadata, and audio streams. The range is 0 to 63. The default values are: <ul style="list-style-type: none"> • 0 for SMPTE 2110-20 (Video) • 0 for SMPTE 2110-40 (Metadata) • 34 for SMPTE 2110-30 (audio)

Video Panel

The Video panel has two tabs (**UDC1** and **UDC2**); one for each of XIP-3901-UDC-IP's independent processing channels. The configuration of the **UDC2** tab is the same as the **UDC1** tab. Only the configuration of the **UDC1** tab is shown below.

Timing Tab

For each processing channel, you can adjust the timing relative to the reference. Use the slider or type a value into the data box on the right of the slider. Metadata and audio streams will match the video delay set below.



Figure 8-13: Video Timing Tab

The following adjustment sliders are available:

Adjustment	Range (50 Hz)	Range (59 Hz)	Description
Vertical (Lines)	200 to +200	200 to +200	Vertical setting applies to all output formats.

Adjustment	Range (50 Hz)	Range (59 Hz)	Description
1920x1080p (A) Horizontal (msec)	0 to 17.771 msec	0 to 14.825 msec	Horizontal settings are specific to individual output formats.
1920x1080i Horizontal (msec)	0 to 35.542 msec	0 to 29.646 msec	
1280x720p Horizontal (msec)	0 to 26.653 msec	0 to 22.231 msec	
Additional Frame Delay	0 to 6	0 to 6	Manage frames for progressive outputs and fields for interlaced format. With interlaced formats, the slider jumps by steps of 2 fields.

This section also displays the Processing Delay in microseconds so you can manage the processing delay on your system.

The following table shows the amount of time for a vertical line.

Input Video Format Setting	Output Video Format	Line length	Description
1280x720p 59Hz	Auto (Follow Input)	22.244 μ sec	Frame rate follows Input - video format (detected video format)
1280x720p 50Hz		26.667 μ sec	
1920x1080p 23.98Hz		37.074 μ sec	
1920x1080p 29.97Hz		29.659 μ sec	
1920x1080i 59Hz		29.659 μ sec	
1920x1080i 50Hz		35.556 μ sec	
1920x1080p 59Hz		14.830 μ sec	
1920x1080p 50Hz		17.778 μ sec	
3840x2160p 23.98Hz		37.074 μ sec	
3840x2160p 29.97Hz		29.659 μ sec	
3840x2160p 59Hz		14.830 μ sec	
3840x2160p 50Hz		17.778 μ sec	

Input Video Format Setting	Output Video Format	Line length	Description
Ignored	1280x720p 59Hz	22.244 μ sec	Frame rate follows Output - video format
	1280x720p 50Hz	26.667 μ sec	
	1920x1080p 23.98Hz	37.074 μ sec	
	1920x1080p 29.97Hz	29.659 μ sec	
	1920x1080i 59Hz	29.659 μ sec	
	1920x1080i 50Hz	35.556 μ sec	
	1920x1080p 59Hz	14.830 μ sec	
	1920x1080p 50Hz	17.778 μ sec	
	3840x2160p 23.98Hz	37.074 μ sec	
	3840x2160p 29.97Hz	29.659 μ sec	
	3840x2160p 59Hz	14.830 μ sec	
	3840x2160p 50Hz	17.778 μ sec	

De-interlacer Tab

Each processing channel has its own de-interlacer for use with interlaced sources. The Film Mode and Video Over Film settings can either be set to **On** or **Off**. By default, both are set to **On** for optimal performance.

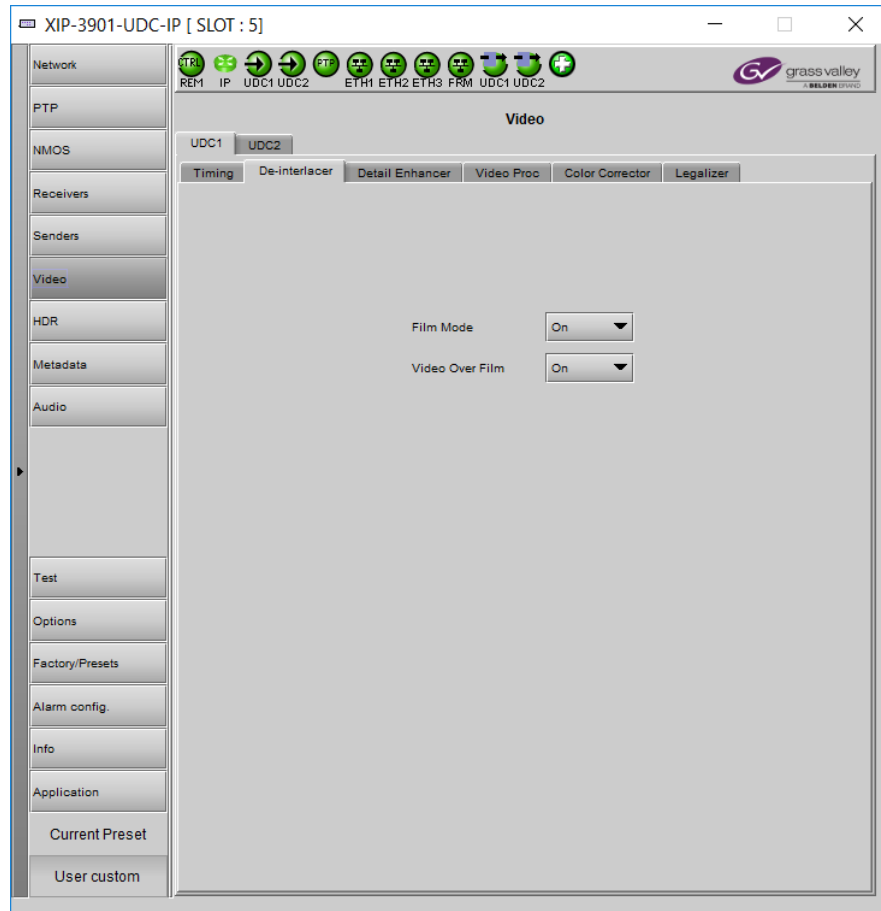

Figure 8-14: De-interlacer Timing Tab

Property	Description
Film Mode	Some interlaced video sources are film-based, originating from 24p film images. When Film Mode is on, the de-interlacer will monitor the input for this type of source. When detected, it will merge the fields to recreate the original 24p image, thereby avoiding de-interlacer artifacts prior to scaling and upconversion. Film detection is provided for 3:2, 2:2 (59 Hz and 50 Hz sources) and 5:5 sequences.
Video Over Film	Video Over Film is available only when Film Mode is enabled. When Video Over Film is on, the de-interlacer will detect video over film content and bypass field-merging on certain video regions such as scrolling video characters over an entire film frame, thereby preventing any unwanted combing effects.

Detail Enhancer Tab

The Detail Enhancer allows you to apply a level of enhancement to the signal to regain lost detail or to simply create a sharper image. Horizontal and Vertical slide controllers allow you to adjust the magnitude of the enhancer to be set both horizontal and vertical directions. These controls only work after down-scaling of video resolution. For example, 2160p to 1080p or 1080i for instance.

The **Mode** Control allows you to select the particular luminance frequency band to be enhanced – Medium Frequency or High frequency.

Horizontal and Vertical Enhancer Controls are usually used with restraint by only making minor adjustments. The optimum settings of the Horizontal and Vertical Detail Enhancer are dependent on the source. The amount of aliasing on the output will be dependent upon the higher frequencies present in the source content and a balance would need to be established between aliasing artifacts, picture sharpness, and the amount of detail. For example, if the enhancers are configured to allow more high frequency content through, this will have the benefit of making the output pictures appear sharper, but the effect can come at the cost of introducing aliasing to the image.



Figure 8-15: Detail Enhancer Tab

Property	Description
Enable	Set to enable vertical and horizontal enhancement adjustment. The below settings can be adjusted, but they will only be applied when Enable is set.
Mode	Select the particular frequency band to be enhanced: High: Boost the high frequency content of the input signal. Medium: Boost the medium frequency content of the input signal.
Horizontal Detail Enhancer	Set the amount of horizontal detail enhancement to be applied to the video signal. TIP: Use restraint and only make minor adjustments.
Vertical Detail Enhancer	Set the amount of vertical detail enhancement to be applied to the video signal. The Vertical Enhancer adjustment ranges from a <i>soft</i> range (negative values) to a max intensity The Vertical Enhancer adjustment ranges from a <i>soft</i> range (negative values) to a max intensity <i>sharper</i> (positive values): It is not usual practice to want to make pictures <i>softer</i> than the source. However, in some circumstances this is a requirement. For example, when an ultra-sharp high definition content is to be down-converted, the high frequency content of the source may cause aliasing in the downconverted output. By <i>softening</i> the processed pictures, the aliasing can be reduced or eliminated. TIP: Use restraint and only make minor adjustments.
Reset Defaults	Click to revert all controls to their default settings.

Video Proc Tab

The Video Proc controls allow you to apply a correction to the individual signal components of the Y'CrCb color space. This follows the input colorimetry of the one selected in the HDR panel.



Figure 8-16: Video Proc Tab

Property	Description
Enable	Set to enable Y'CrCb color space adjustment.
Master Gain	Set the overall gain (Y and Cb/Cr). Y and C gain may be independently adjusted with the controls shown below. Note: The total range of both Master + Y and Master + C controls is limited to +6 dB to -6 dB
Luma (Y) Gain	Set the Y (Luminance) gain.
Chroma (Cb/Cr) Gain	Set the Cb/Cr (Color difference) gain.
Black Level	Set the Black level.
Hue	Set the Hue of the signal.

Property	Description
Reset Defaults	Click to revert all controls to their default settings.

Color Corrector Tab

The Color Corrector controls allow you to apply correction to the individual primary RGB channels.



Figure 8-17: Color Corrector Tab

Property	Description
Enable	Set to enable RGB color space adjustment.
Gang	Set to adjust all three RGB channels together at the same time. Deselect to adjust the RGB channels individually.
Green Gain	Set the Green Channel Gain value.
Blue Gain	Set the Blue Channel Gain value.
Red Offset (Lift)	Set the Red Channel Offset value.

Property	Description
Green Offset (Lift)	Set the Green Channel Offset value.
Blue Offset (Lift)	Set the Blue Channel Offset value.
Red Gamma	Set the Red Gamma.
Green Gamma	Set the Green Gamma.
Blue Gamma	Set the Blue Gamma.
Reset Defaults	This function allows for all controls to revert to their preset values.

Legalizer Tab

The Legalizer ensures that the output video stays within the legal RGB gamut limit, making it suitable for the broadcast signal chain.

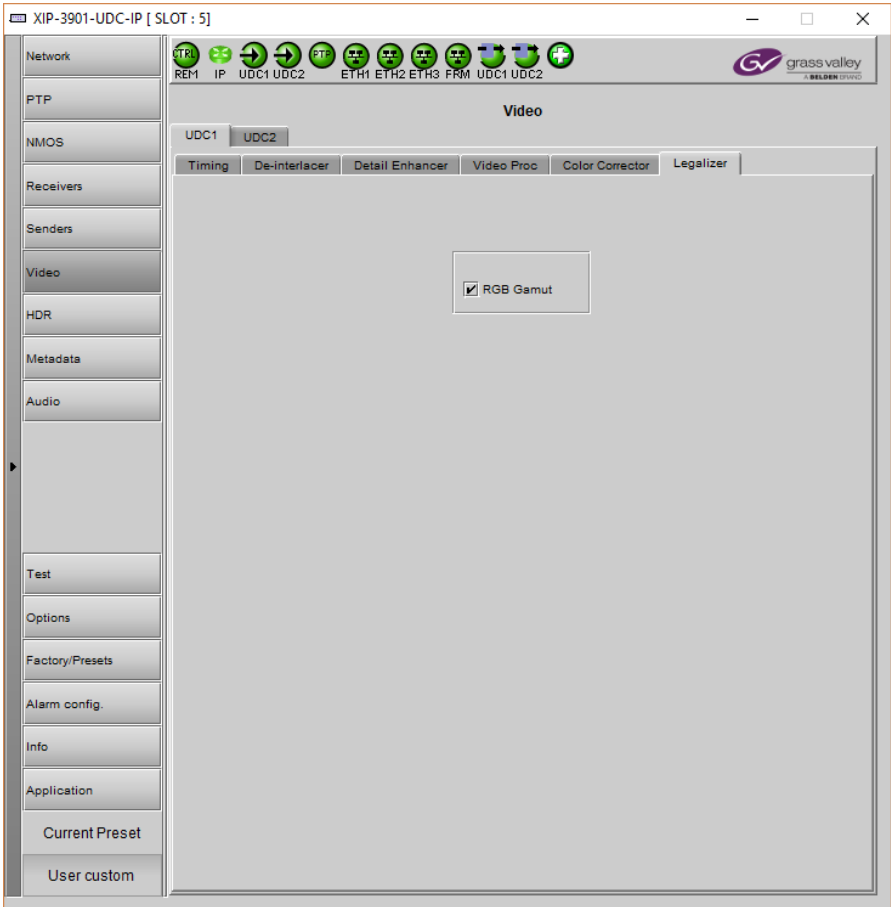

Figure 8-18: Legalizer Tab

Property	Description
RGB Gamut	Set to clip all illegal Y'CbCr colors in the RGB space to a legal value.

HDR Panel

The HDR panel has two tabs (**UDC1** and **UDC2**); one for each of XIP-3901-UDC-IP's independent processing channels. The configuration of the **UDC2** tab is the same as the **UDC1** tab. Only the configuration of the **UDC1** tab is shown below.

UDC1 / UDC2 Tab

Grass Valley offers its own HDR processing. However, you can decide to use BBC LUTs or to load your own Custom LUTs. Furthermore, the incoming Video Payload ID (Transfer Characteristic, Colorimetry, and Bit depth) can be corrected without applying any HDR conversion. Use the radio button to select the desired processing. Grass Valley HDR processing is selected by default.

Grass Valley color space conversion internal LUT's, for example, BT.709 to BT2020 and BT.2020 to BT.709 are always available. Other video processing settings can be enabled for each channel by activating the **XIP-3901-UDC-HDR** option. See [Options Panel](#), on page 176 for details about how to activate card options.



Figure 8-19: HDR UDC1 / UDC2 Tab

Property	Description
Enable	Set to enable color space conversion and dynamic range conversion. When disabled, incoming color space and dynamic range are bypassed without processing. The Applied Conversion statuses will indicate "Bypass". You can change the HDR processing setting values even if processing is disabled, but processing will not be performed. Processing is disabled by default.

Property	Description
Global table > Grass Valley LUTs	<p>Set the LUT to use for HDR processing. The following HDR processing setting are available as part of the Grass Valley LUTs:</p> <ul style="list-style-type: none"> • BT.709 to BT.2020 • BT.2020 to BT.709 • SDR to HLG BT.2100 • SDR to PQ BT.2100 • HLG BT.2100 to SDR • PQ BT.2100 to SDR • PQ BT.2100 to HLG BT.2100 • HLG BT.2100 to PQ BT.2100 • S-Log3 S-Gamut3 to BT.709 800% • S-Log3 S-Gamut3 to HLG BT.2100 • S-Log3 S-Gamut3 to PQ BT.2100
Global table > BBC LUTs	<p>Set the LUT to use for HDR processing. The following HDR processing setting are available as part of the BBC LUTs:</p> <ul style="list-style-type: none"> • SDR to HLG Scene (4-1a - v1.4) • SDR to HLG Scene Strict (4-2a - v1.4) • SDR to HLG Scene Upmap (6-1a - v1.4) • SDR to HLG Scene Upmap Strict (6-2a - v1.4) • SDR to HLG Display (3c - v1.4) • SDR to HLG Display Upmap (5c - v1.4) • HLG to SDR Scene (12-1c - v1.4) • HLG to SDR Scene Strict (12-2c - v1.4) • HLG to SDR Display (8c - v1.4) • HLG to SDR Display Harsh (9c - v1.4) • PQ 1000 Nits Full Range to HLG (1c - v1.4) • PQ 1000 Nits Narrow Range to HLG (1e - v1.4) • PQ 4000 Nits Full Range to HLG (2c - v1.4) • PQ 4000 Nits Narrow Range to HLG (2e - v1.4) • HLG to PQ 1000 Nits Narrow range (7c - v1.4) • SLog3 100% Scene to HLG (10a - v1.4) • SLog3 200% Scene to HLG (11a - v1.4) • Unity
Global table > Custom LUTs	<p>Set the LUT to use for HDR processing. You can pre-load up to 8 custom HDR conversions on the card. These are configured in the Custom Luts tab.</p>

Property	Description
Global table > Only force colorimetry fields in VPID/SDP	<p>Set to force the use of an SDP File. Sometimes, incoming HDR processing is not flagged properly by its SDP File. You can use this option to correct the outgoing SDP File:</p> <ul style="list-style-type: none"> • SDR BT.709 Narrow • HLG BT.2020 Narrow • PQ BT.2020 Narrow • PQ BT.2020 Full <p>Note: This application does not use the input Video Payload ID (Transfer Characteristic, Colorimetry, and Bit depth).</p>
Grass Valley LUTs table > HLG BT.2100 to SDR – Input HDR Ref White (nits)	<p>Set the <i>reference white</i> luminance level in nits that will become 100% white in the SDR output. The value range must be between 100 and 1000 nits. The default value is 203 nits. This parameter is only applied when the Grass Valley HLG BT.2100 to SDR LUT is selected.</p>
Grass Valley LUTs table > SDR to HLG BT.2100 – Output HDR Ref White (nits)	<p>Set the <i>reference white</i> luminance level in nits for the HDR output that represents 100% white in the SDR input. The value range must be between 100 and 1000 nits. The default value is 203 nits. This parameter is only applied when the Grass Valley SDR to HLG BT.2100 LUT is selected.</p>
Grass Valley LUTs table > PQ BT.2100 to SDR – Input HDR Ref White (nits)	<p>Set the <i>reference white</i> luminance level in nits that will become 100% white in the SDR output. The value range must be between 100 and 1000 nits. The default value is 203 nits. This parameter is only applied when the Grass Valley PQ BT.2100 to SDR is selected.</p>
Grass Valley LUTs table > PQ BT.2100 to SDR – Input Range	<p>Set the input range to Full or Narrow:</p> <ul style="list-style-type: none"> • Full: 0 to 1023 image mapping range according to SMPTE RP. 2077. • Narrow: The standard 64 to 940 image mapping broadcast range. <p>This parameter is only applied when the Grass Valley PQ BT.2100 to SDR LUT is selected.</p>
Grass Valley LUTs table > SDR to PQ BT.2100 – Output HDR Ref White (nits)	<p>Set the <i>reference white</i> luminance level in nits for the HDR output that represents 100% white in the SDR input. The value range must be between 100 and 1000 nits. The default value is 203 nits. This parameter is only applied when the Grass Valley SDR to PQ BT.2100 LUT is selected.</p>
Grass Valley LUTs table > SDR to PQ BT.2100 – Output Range	<p>Set the output range to Full or Narrow:</p> <ul style="list-style-type: none"> • Full: 0 to 1023 image mapping range according to SMPTE RP. 2077. • Narrow: The standard 64 to 940 image mapping broadcast range. <p>This parameter is only applied when the Grass Valley SDR to PQ BT.2100 LUT is selected.</p>

Property	Description
Applied Conversions table > Colorimetry	Shows the applied conversion according to the above settings.
Transfer Characteristic	
Range	

Custom Luts Tab

This tab allows you to load up to 8 custom LUTs (**LUT1** to **LUT8**) that can be selected for use in the **UDC1** / **UDC2** tabs. The XIP only supports files that conform to the Adobe Cube file v1.0 format. Custom LUTs are shared among all XIP applications. This feature requires the **XIP-3901-UDC-HDR** option. See [Options Panel](#), on page 176 for details about how to activate card options.

You can Load up to 8 LUTs. For each custom LUT you load, you need to specify input/output colorimetry, input/output range and output transfer characteristics.

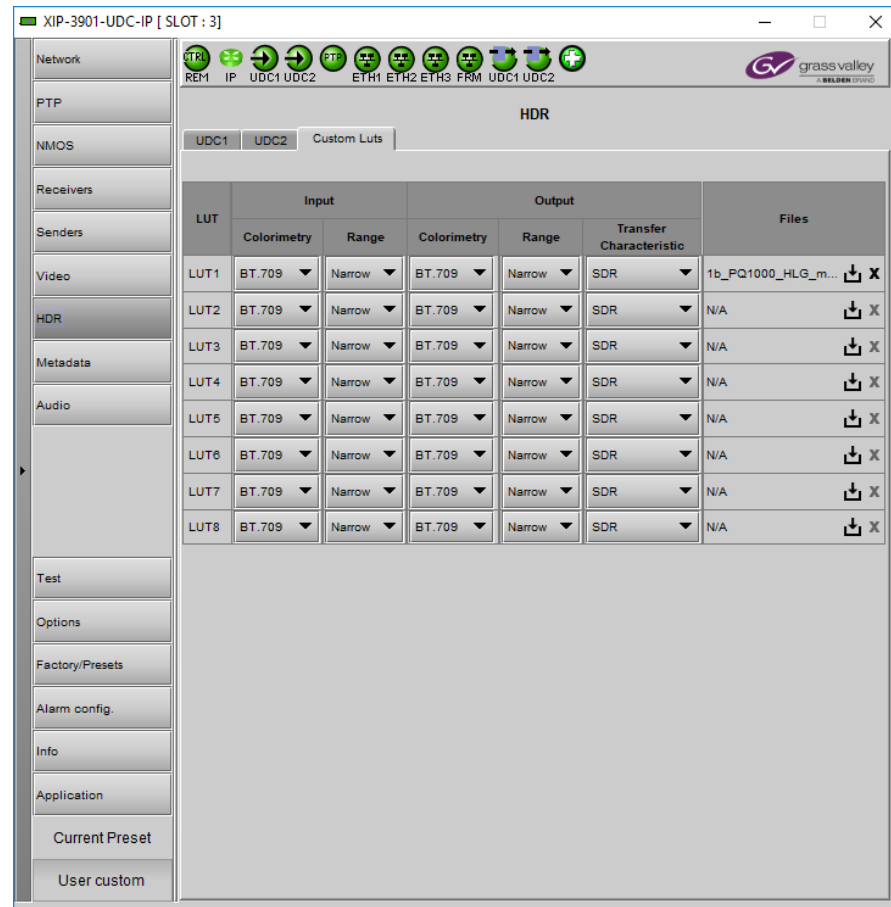



Figure 8-20: Custom LUTs Tab

Property	Custom LUTs Parameters	Available Values / Description
Input	Colorimetry	BT.709, BT.2020
	Input Range	Narrow, Full
Output	Colorimetry	BT.709, BT.2020
	Output Range	Narrow, Full
	Transfer Characteristic	SDR, HLG, PQ, Unspecified
Files	–	<p>Click  to upload or replace a LUT file.</p> <p>Click X to remove the currently loaded LUT file.</p> <p>The name of the currently loaded LUT file will be partially displayed. Mouse-over the field to display the full name.</p> <p>The background will change to RED if the uploaded file is invalid.</p>

Metadata Panel

The Metadata panel has two tabs (**UDC1** and **UDC2**); one for each of XIP-3901-UDC-IP's independent processing channels. The configuration of the **UDC2** tab is the same as the **UDC1** tab. Only the configuration of the **UDC1** tab is shown below.

The XIP-3901-UDC-IP manages the transfer of metadata between its input and output, but does not process the metadata information regarding the video conversion. In the Metadata Panel, you can selectively pass or block any one of eight specific ANC data types by specifying the DIDs and SDIDs to be passed from input to output and those that are to be blocked.

In the case of **Time Code** option, when set to the **Process** mode, this activates the controls under the **Timecode** tab.

Configuring the XIP-3901-UDC-IP v1.2 Application with iControl
 Metadata Panel

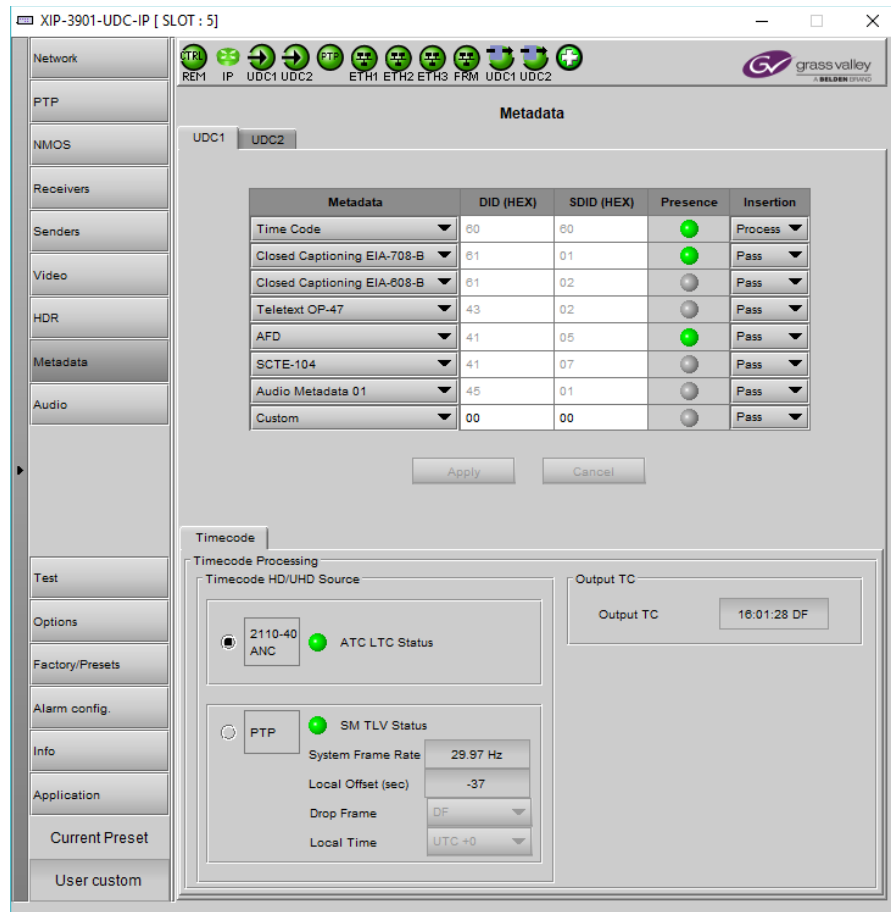

Figure 8-21: Metadata panel

Property	Description
Metadata DID (HEX) SDID (HEX)	<p>Use any of the eight pulldowns to select the metadata you want to pass or block. You can select any predefined Metadata and the card will manage DID and SDID for you:</p> <ul style="list-style-type: none"> • Time Code: DID/SDID = 60h/60h. When set to Process mode, this activates the controls under the Timecode tab at the bottom of the panel. • Closed Captioning EIA-708-B: DID/SDID = 61h/01h • Closed Captioning EIA-608-B: DID/SDID = 61h/02h • Teletext OP-47: DID/SDID = 43h/02h • AFD: DID/SDID = 41h/05h • SCTE 104: DID/SDID = 41h/07h • Audio Metadata 01: DID/SDID = 45h/01h • Audio Metadata 02: DID/SDID = 45h/02h • Audio Metadata 03: DID/SDID = 45h/03h • Audio Metadata 04: DID/SDID = 45h/04h • Audio Metadata 05: DID/SDID = 45h/05h • Audio Metadata 06: DID/SDID = 45h/06h • Audio Metadata 07: DID/SDID = 45h/07h • Audio Metadata 08: DID/SDID = 45h/08h • Audio Metadata 09: DID/SDID = 45h/09h • Custom: you can specify a custom metadata by specifying DID and SDID. <p>You cannot set the same metadata twice based on DID and SDID.</p>
Presence	<p>Shows if the selected metadata type has been detected. The status indicator shows the current metadata status:</p> <p>Green: the selected metadata is present. Grey: the selected metadata is not present.</p>
Insertion	<p>Set whether the detected ancillary packet is to be inserted into the card's output:</p> <p>Pass: allow the detected ancillary packet is to be passed through the card. Block: drop the detected ancillary packet from being passed through the card. Process: When Timecode is set to Process mode, this activates the controls under the Timecode tab at the bottom of the panel.</p>
Apply Cancel	<p>When active, this applies or rejects your current changes made in this tab.</p>

Property	Description
Timecode HD/UHD Source	<p>Select the source containing Timecode information for further processing.</p> <p>2110-40 ANC: Extract Timecode from the 2110-40 metadata stream in the format of ATC LTC timecode. The presence status of ATC LTC timecode is reflected through the color of the associated LED:</p> <ul style="list-style-type: none"> • Green: ATC LTC timecode packet present • Red: ATC LTC timecode packet not present <p>PTP: Extract Timecode from the PTP packet and extract the following additional information from the TLV messages:</p> <ol style="list-style-type: none"> 1 System Frame Rate associated with the timecode information. 2 Style of Timecode DF (drop frame) or NDF (non-drop frame). 3 Local Offset and the derive Local Time form Local Offset. <p>The presence status of all three TLV's is reflected through the color of the associated LED:</p> <ul style="list-style-type: none"> • Green: SM TLV timecode packet present • Red: SM TLV timecode packet not present
Drop Frame	<p>For the PTP option, when there is no TLV Status (status LED is red), set the timecode type with the dropdown list:</p> <p>DF: Drop frame.</p> <p>NDF: Non-drop frame.</p>
Local Time	<p>For the PTP option, when there is no TLV Status (status LED is red), set your UTC time zone offset for your geographic location with the dropdown list.</p>
Output TC	<p>Shows the output timecode in Hours:Min:Sec and the timecode type: DF (drop frame) or NDF (non-drop frame). Only active when Time Code under Metadata is set to Process.</p>

Audio Panel

The Audio panel has two tabs (**UDC1** and **UDC2**); one for each of XIP-3901-UDC-IP's independent processing channels. The configuration of the **UDC2** tab is the same as the **UDC1** tab. Only the configuration of the **UDC1** tab is shown below.

For **Audio 2** to **Audio 4**, only the first 16 channels will carry active audio and channels 17-64 will carry silence.

The relative processing order of audio panel components is shown below.

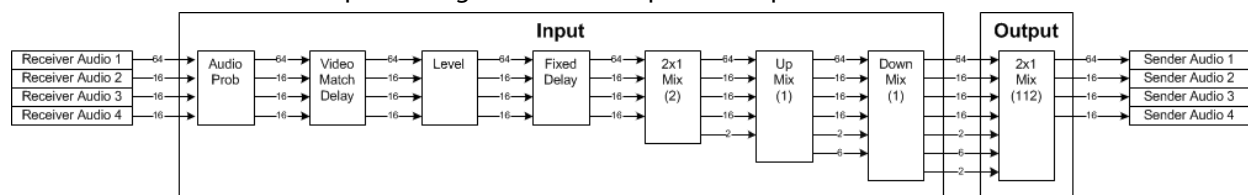

Figure 8-22: Overview of XIP-3901-UDC-IP Audio Processing

Certain of the above audio processing components are only available when the **XIP-3901-UDC-AUD** option is enabled. See [Optional XIP-3901-UDC-IP Application Audio processing, Down/Up Mix, Shuffling](#), on page 27 for the feature overview for this licensed option.

Inputs Tab

This tab allows you to set individual audio stream input parameters such as the level, delay, phase invert, and to mute an input. This tab also supports audio probing: embedded audio group detection, audio presence and audio type for all incoming audio channels. There are also tabs for incoming audio: **Audio 1**, **Audio 2**, **Audio 3**, and **Audio 4**. This feature requires the **XIP-3901-UDC-AUD** option. See [Options Panel](#), on page 176 for details about how to activate card options.

Tab	Audio Channels Supported
Audio 1	CH1 to CH64
Audio 2	CH1 to CH16
Audio 3	CH1 to CH16
Audio 4	CH1 to CH16

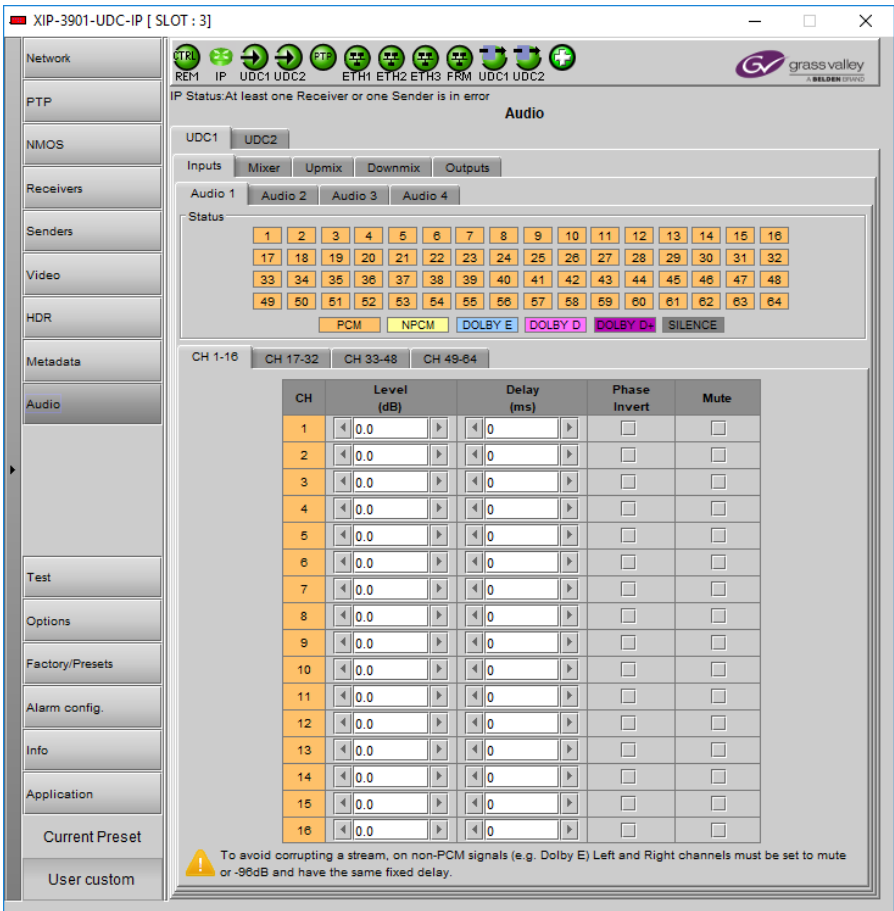
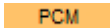
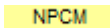
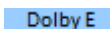
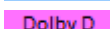
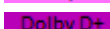



Figure 8-23: Audio Inputs Tab

Property	Description
Status	Shows audio group 1 to 4 detection for embedded audio: Green: Audio Group present Grey: Audio Group not present  PCM Signal is present and detected audio type is PCM  NPCM Signal is present and detected audio type is NPCM  Dolby E Signal is present and detected audio type is Dolby E  Dolby D Signal is present and detected audio type is Dolby Digital (Dolby D)  Dolby D+ Signal is present and detected audio type is Dolby Digital plus (Dolby D+)  Silence Signal not present because a silence of -60 dBFS or less was detected for over 3 seconds
Level	Sets input gain level for an audio channel. At -96dB, the signal is completely muted. You can mouse over the level setting to see the available range. The range is always -96 to 12dB and can be set in 0.5 dB steps. By default no gain level is applied (0 dB). This setting has no effect on a non-PCM audio channel except if this level is set to -96dB (signal is muted). This feature requires the XIP-3901-UDC-AUD option. See Options Panel , on page 176 for details about how to activate card options.
Delay	You can delay or advance audio from the nominal value, in order to deal with problems such as lip-sync errors and audio phase alignment in the incoming feed. You can delay of up to 500 ms in steps of 1ms. To advance audio, you need first to delay the video. Video can be delayed up to 6 fields/frames. As an example, if you delay 1920x1080p59Hz output by 2 frames, you can advance the audio by up to 66ms. At any time you can mouse over this field to see the current available fixed delay range. By default no fixed delay is applied (0ms). A fixed delay can still be used with non-PCM signals, but you must use the same delay values for the left and right channels to preserve signals such as Dolby E. This feature requires the XIP-3901-UDC-AUD option. See Options Panel , on page 176 for details about how to activate card options.
Phase Invert	Set to phase invert an audio channel. This setting has no effect on a non-PCM audio channel. By default, phase invert is disabled. This feature requires the XIP-3901-UDC-AUD option. See Options Panel , on page 176 for details about how to activate card options.
Mute	Set to mute an audio channel. By default, mute is disabled.

Mixer Tab

This tab provides two 2 × 1 mixers. Each mixer will add two new audio mix output channels that are added to the audio processing path: **Mixer - CH1** and **Mixer - CH2**. These channels are available as inputs to other audio processing tabs. See also [Overview of XIP-3901-UDC-IP Audio Processing](#), on page 164.

All incoming audio channels are available for mixing:

Audio Channel	Description
Audio 1 - CH1 to CH64	Audio coming from the 1st audio receiver.
Audio 2 - CH1 to CH16	Audio coming from the 2nd audio receiver.
Audio 3 - CH1 to CH16	Audio coming from the 3rd audio receiver.
Audio 4 - CH1 to CH16	Audio coming from the 4th audio receiver.

This feature requires the XIP-3901-UDC-AUD option. See [Options Panel](#), on page 176 for details about how to activate card options.

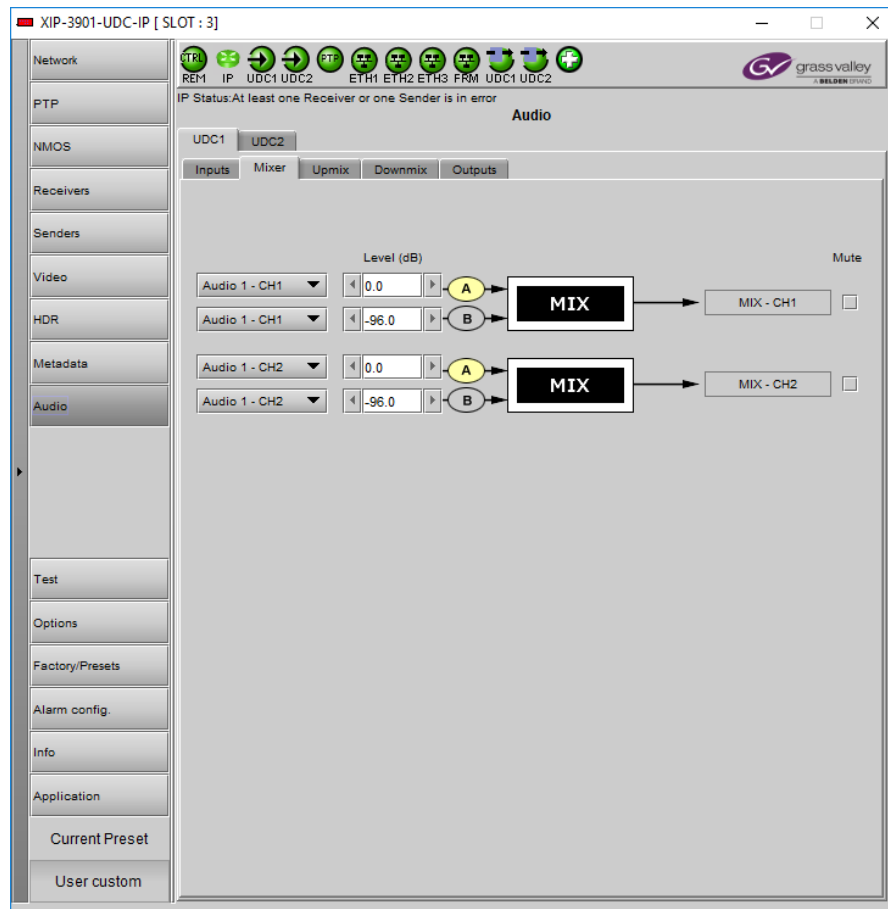

Figure 8-24: Audio Mixer Tab

Property	Description
Inputs: Mixer Source A and Source B	Select audio sources.

Property	Description
Level	Sets input gain level for an audio channel. At -96dB, the signal is completely muted. You can mouse over the level setting to see the available range. The range is always -96 to 12dB and can be set in 0.5 dB steps. By default no gain level is applied (0 dB). By default, Source A is passed-through and Source B is muted. If one audio mix input channel is non-PCM, Source A will pass-through except if its level setting is -96dB (signal is muted).
Mute	Set to mute a mixed audio channel output. By default, mixed signals are not muted.

Upmix Tab

This tab allows you to upmix stereo audio channels into simulated 5.1 surround sound. Upmix generates 6 new audio channels that are added to the audio processing path: **UPMIX - CH1 to CH6** that can be used as inputs to other audio processing tabs. See also [Overview of XIP-3901-UDC-IP Audio Processing](#), on page 164.

All incoming audio channels and new mixed audio channels are available:

Audio Channel	Description
Audio 1 - CH1 to CH64	Audio coming from the 1st audio receiver.
Audio 2 - CH1 to CH16	Audio coming from the 2nd audio receiver.
Audio 3 - CH1 to CH16	Audio coming from the 3rd audio receiver.
Audio 4 - CH1 to CH16	Audio coming from the 4th audio receiver.
Mixer - CH1 to CH2	Mixed audio channels.

This feature requires the **XIP-3901-UDC-AUD** option. See [Options Panel](#), on page 176 for details about how to activate card options.



Figure 8-25: Audio Upmix Tab

Property	Description
Inputs: Left (L), Right (R) Inputs	Select audio sources. If one or more upmix input channel is non-PCM, all UPMIX output channels will be muted.
Operation	OFF: Disable upmix processing. UPMIX – CH1 to UPMIX – CH6 outputs are muted. ON: Enable upmix processing. By default, upmix is disabled.
Stereo Mix Level	Set the gain level for the left and right upmix channels. Possible values are: +3.0 dB, +1.5 dB, 0.0 dB, -1.5 dB, -3.0 dB, -4.5 dB, -6.0 dB and Mute. The default level is -3.0 dB.
Center Mix Level	Set the gain level for the center upmix channel. Possible values are: +3.0 dB, +1.5 dB, 0.0 dB, -1.5 dB, -3.0 dB, -4.5 dB, -6.0 dB, and Mute. The default level is -3.0 dB.
Surround Mix Level	Set the gain level for the left surround and right surround upmix channels. Possible values are: +3.0 dB, +1.5 dB, 0.0 dB, -1.5 dB, -3.0 dB, -4.5 dB, -6.0 dB, and Mute. The default level is -3.0 dB.

Property	Description
LFE Mix Level	Set the gain level for the low-frequency effects (LFE) upmix channel. Possible values are: +10.0 dB, + 9.0 dB, +7.5 dB, +6.0 dB, +4.5 dB, +3.0 dB, +1.5 dB, 0.0 dB, -1.5 dB, -3.0 dB, -4.5 dB, -6.0 dB, and Mute. The default level is Muted.
LFE Filter Frequency	Set the crossover frequency for bass at which: <ul style="list-style-type: none"> • Bass program content is filtered to the low-frequency effects (LFE) upmix channel. • The remaining upper frequency band is filtered to the other upmix channels (left, right, center, left surround, and right surround). • The default frequency is 120Hz.

Downmix Tab

This tab allows you to downmix a 5.1 surround sound signal to a LoRo or LtRt stereo channel pair. Downmix generates 2 new audio channels that are added to the audio processing path: **DMIX - CH1 to CH2** that can be used as inputs to other audio processing tabs. See also [Overview of XIP-3901-UDC-IP Audio Processing](#), on page 164.

All incoming audio channels, new mixed and upmixed audio channels are available:

Audio Channel	Description
Audio 1 - CH1 to CH64	Audio coming from the 1st audio receiver.
Audio 2 - CH1 to CH16	Audio coming from the 2nd audio receiver.
Audio 3 - CH1 to CH16	Audio coming from the 3rd audio receiver.
Audio 4 - CH1 to CH16	Audio coming from the 4th audio receiver.
Mixer - CH1 to CH2	Mixed audio channels.
Upmix - CH1 to CH6	Upmixed audio channels.

This feature requires the **XIP-3901-UDC-AUD** option. See [Options Panel](#), on page 176 for details about how to activate card options.

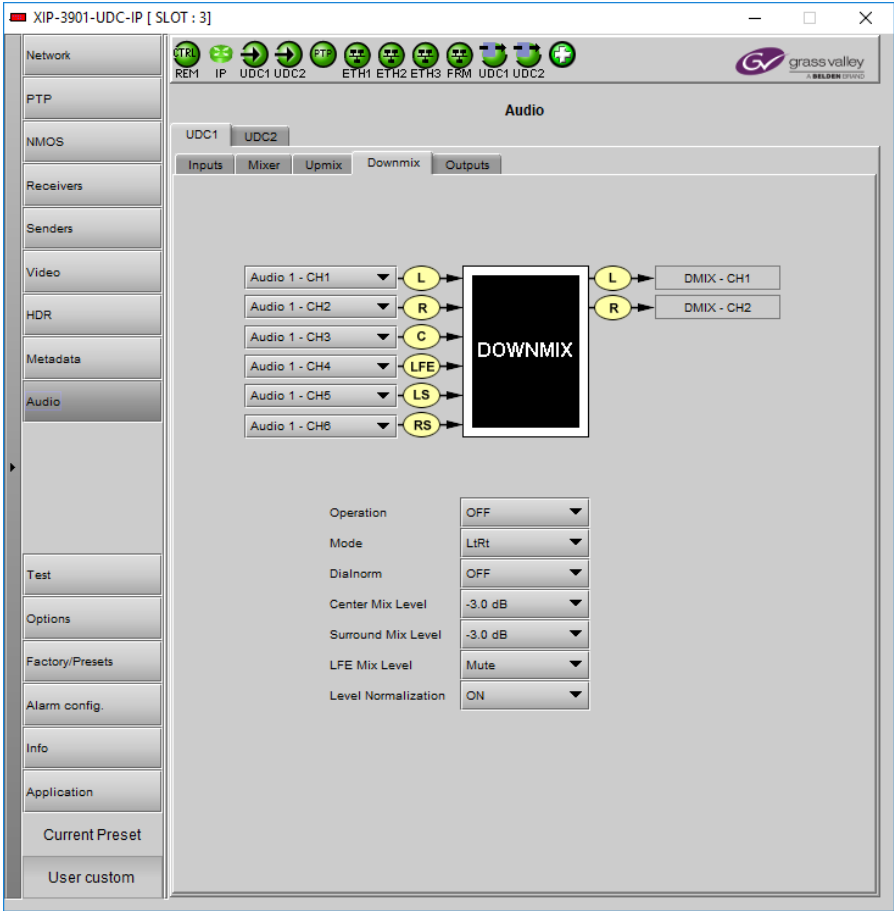
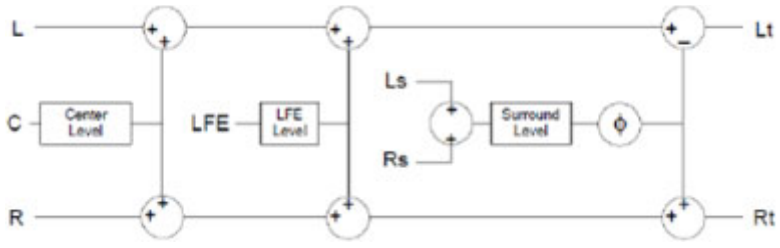
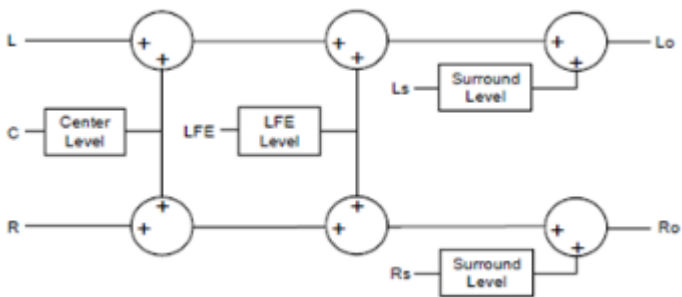

Figure 8-26: Audio Downmix Tab

Property	Description
Inputs: Left (L), Right (R), Center (C), LFE, Left surround (LS) and Right surround (LR)	Select audio sources. If one or more downmix input channel is non-PCM, all DMIX output channels will be muted.
Operation	OFF: Disable downmix processing. DMIX – CH1 and DMIX – CH2 outputs are muted. ON: Enable downmix processing.

Property	Description
Mode	<p>LtRt: Enables the downmix of 5.1 channels into an LtRt (Left total Right total) matrix surround encoded stereo pair.</p>  <p>LoRo: Enables the downmix of 5.1 channels into a LoRo (Left only Right only) stereo pair, which is a conventional stereo signal.</p> 
Dialnorm	Set the dialog normalization level. Possible values are: -31 dBFS to -1 dBFS, and OFF. Default value is OFF.
Center Mix Level	Set the gain level for the center downmix channel. Possible values are: +3.0 dB, +1.5 dB, 0.0 dB, -1.5 dB, -3.0 dB, -4.5 dB, -6.0 dB, and Mute. The default level is -3.0 dB.
Surround Mix Level	Set the gain level for the left surround and right surround downmix channels. Possible values are: +3.0 dB, +1.5 dB, 0.0 dB, -1.5 dB, -3.0 dB, -4.5 dB, -6.0 dB, and Mute. The default level is -3.0 dB.
LFE Mix Level	Set the gain level for the low-frequency effects (LFE) downmix channel. Possible values are: +10.0 dB, +9.0 dB, +7.5 dB, +6.0 dB, +4.5 dB, +3.0 dB, +1.5 dB, 0.0 dB, -1.5 dB, -3.0 dB, -4.5 dB, -6.0 dB, and Mute. The default level is mute.
Level Normalization	OFF: Disable output level normalization. ON: Enable output level normalization: the output level is normalized based on the applied mix levels to provide a uniform output over the range of mix levels available. Clipping will never occur, even with full scale input channels and mix levels. Default value is ON.

Outputs Tab

This tab allows you to shuffle and mix audio output streams down to a maximum of 128 output channels. There is a tab for each audio output: **Audio 1**, **Audio 2**, **Audio 3**, and **Audio 4**.

All incoming audio channels and all new generated audio channels are available:

Audio Channel	Description
Audio Channel	Description
Audio 1 - CH1 to CH64	Audio coming from the 1st audio receiver.
Audio 2 - CH1 to CH16	Audio coming from the 2nd audio receiver.
Audio 3 - CH1 to CH16	Audio coming from the 3rd audio receiver.
Audio 4 - CH1 to CH16	Audio coming from the 4th audio receiver.
Mixer - CH1 to CH2	Mixed audio channels.
Upmix - CH1 to CH6	Upmixed audio channels.
Dmix - CH1 to CH2	Downmixed audio channels.

The output processing (shuffler and mixer) will set the following outgoing audio channels:

Output Audio Channel	Description
Output Audio Channel	Description
Audio 1 CH1 to CH64	1st audio sender.
Audio 2 CH1 to CH16	2nd audio sender.
Audio 3 CH1 to CH16	3rd audio sender.
Audio 4 CH1 to CH16	4th audio sender.

Configuring the XIP-3901-UDC-IP v1.2 Application with iControl
Test Panel



Figure 8-27: Audio Outputs Tab

Property	Description
Inputs: Mixer Source A and Source B	Select audio sources.
Level	Sets input gain level for an audio channel. At -96dB, the signal is completely muted. You can mouse over the level setting to see the available range. The range is always -96 to 12dB and can be set in 0.5 dB steps. By default no gain level is applied (0 dB). By default, Source A is passed-through and Source B is muted. If one audio mix input channel is non-PCM, Source A will pass-through except if its level setting is -96dB (signal is muted).
Mute	Set to mute a mixed audio channel output. By default, mixed signals are not muted.

Test Panel

You may activate the Color Bars & Tone test signal for the two channels independently by enabling the appropriate checkboxes. When HDR the XIP-3901-UDC-HDR option is

activated, HDR test patterns are available. See [Options Panel](#), on page 176 for details about how to activate card options.





Figure 8-28: Test Panel

Property	Description
Color Bars & Tone	<p>Enables test signals at the card's output:</p> <ul style="list-style-type: none"> • Video: Generate a video test pattern. On HD Video outputs, this will generate a 75% color bar with 75% white. On 1080p & 2160p Video outputs, test pattern will follow the format setting. • Audio: Generate a 1 KHz sine wave at -18dBFS on all audio channel outputs: <ul style="list-style-type: none"> Continuous tone on right channel; pulsed tone on left channel of every pair (250 ms pulse every 3 seconds). Audio tones enabled on all 16 embedded audio channels and on all streamed audio channels. • Metadata: blank

Property	Description
Format	Set video test pattern format for 1080p & 2160p Video outputs: <ul style="list-style-type: none"> • SDR BT.709 (75%): 75% Color bar with 75% white • HLG BT.2110-0: Test pattern HLG narrow range as per ITU-R BT.2111-0 • PQ Narrow BT.2111-0: Test pattern PQ narrow range as per ITU-R BT.2111-0 • PQ Full BT 2111-0: Test pattern PQ full range as per ITU-R BT.2110-0

Status

When Test mode is activated on a channel, the status icon display for that channel will show the Color Bars & Tone icon.

Test Pattern	Operating Mode	Icon
Enabled	Color Bars & Tone	
Disabled	Process	

Options Panel

The following options are available for the XIP-3901-UDC-IP and XIP-3901-UDC-IF applications:

- **XIP-3901-UDC-HDR**: Enables the card's HDR conversion function. When this option is activated, all HDR conversion settings are available. When it is not activated, only the BT.709 to BT.2020 and BT.2020 to BT.709 settings are available. See also [Optional HDR Processing](#), on page 35.
See [UDC1 / UDC2 Tab](#), on page 156 to see all settings available with this option.
- **XIP-3901-UDC-AUD**: Enables the card's audio probing and processing.
 - For the XIP-3901-UDC-IP application, see:
 - [Optional XIP-3901-UDC-IP Application Audio processing, Down/Up Mix, Shuffling](#), on page 27 for the feature overview for this licensed option.
 - [Audio Panel](#), on page 164 to see all settings available with this option.
 - For the XIP-3901-UDC-IF application, see:
 - [Optional XIP-3901-UDC-IF v4.0 Application Audio processing, Down/Up Mix, Shuffling](#), on page 31 for the feature overview for this licensed option.
 - [Audio Panel](#), on page 225 to see all settings available with this option.

To activate an option, you must:

- 1 Obtain a license key for the option from Grass Valley.
- 2 Open the Options panel and select the appropriate tab.
- 3 Type the license key in the Enter key box.
- 4 Click **Enable option** to enable the option's features.

Once the option is activated, the status box beneath the Enter key area will show the status as active, with a green background.

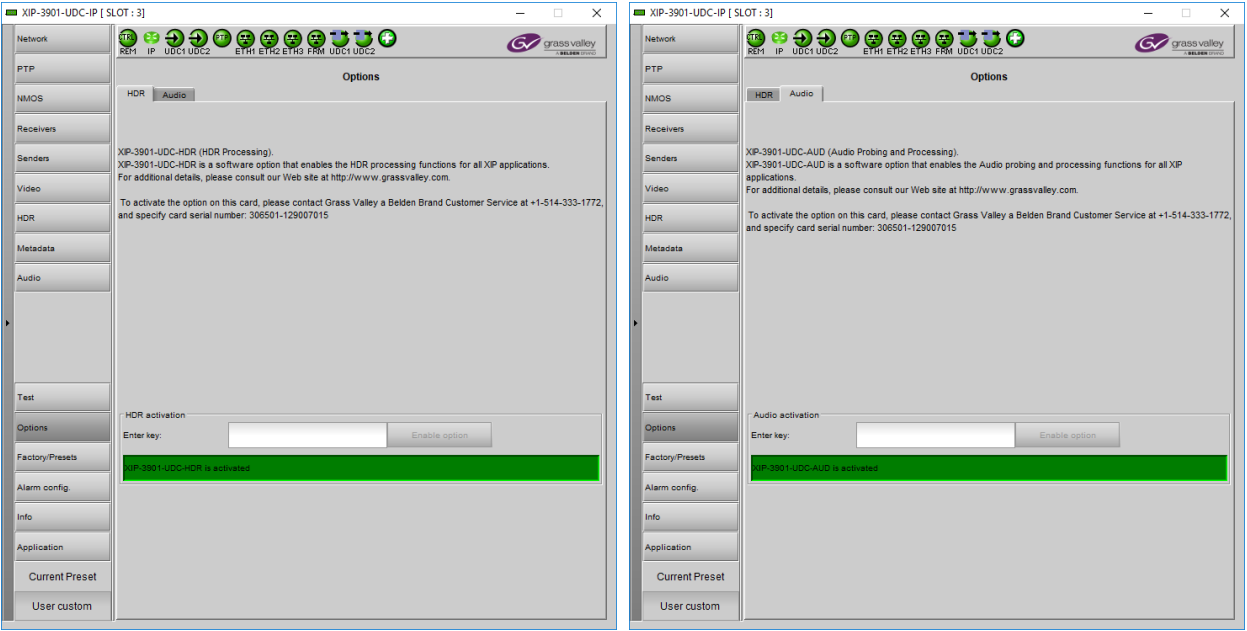

Figure 8-29: Typical Options Panel

Configuring the XIP 3901-UDC-IF v4.0 Application with iControl

XIP-3901-UC, XIP-3901-DC, or XIP-3901-FS	XIP-3901-UDC-IP	XIP-3901-UDC-IF	XIP-3901-GB-IP	XIP-3901-JPEG XS	XIP-3901-ASI
		•			

This section describes the control panels associated with the XIP-3901-UDC-IF application and its use.

Setting the Card's Operating Mode

The first step to configure an XIP-3901-UDC-IF is to set the card's **Operating Mode** in the **Factory Presets** panel. See [Factory/Presets Panel](#), on page 249. When the **SDI Only** option for the **Operating Mode** has been selected, certain configuration panels related to the card's high-speed Ethernet IP interfaces cannot be configured. When the **Dual UHD/HD** option for the **Operating Mode** has been selected, configuration parameters related to **UDC3** and **UDC4** in all configuration screens become unavailable.

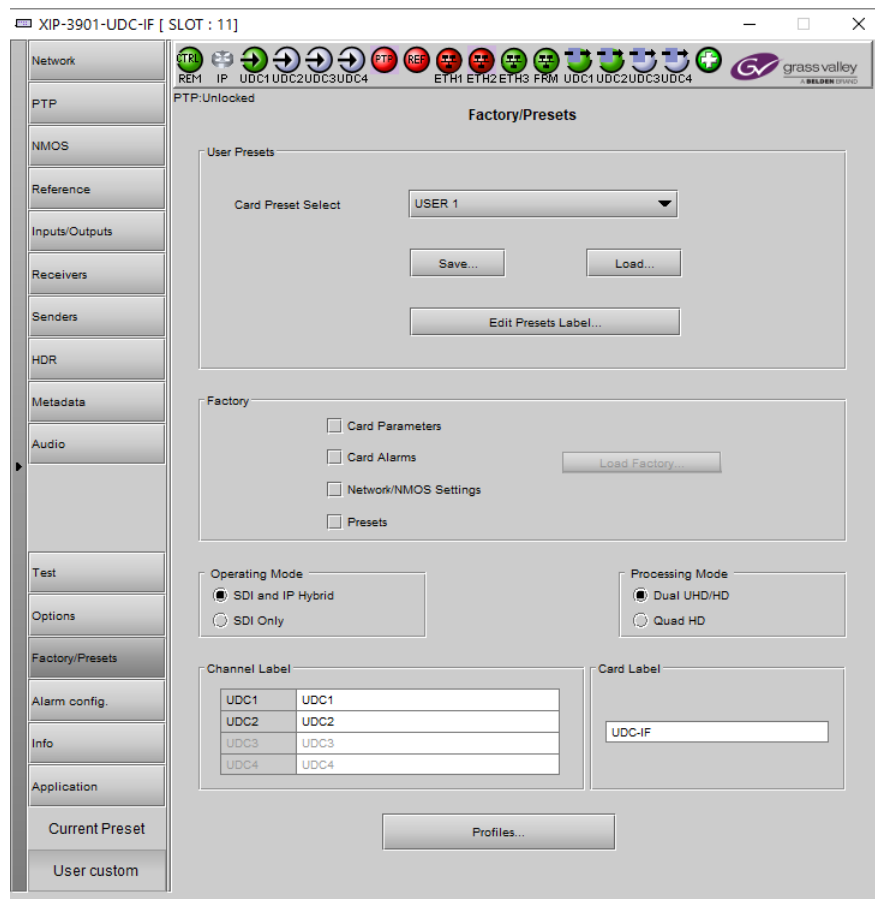

Fig. 9-1: *Factory/Presets Panel*

Property	Description
Operating Mode	<p>Set the XIP-3901-UDC-IF card's operating mode.</p> <p>SDI and IP Hybrid: All functions of the XIP-3901-UDC-IF application are available as shown in Figure 13 - XIP-3901-UDC-IF Functional Block Diagram, on page 27.</p> <p>SDI Only: Disables the IP functions of the XIP-3901-UDC-IF application. When this option is enabled:</p> <ul style="list-style-type: none"> The card's two high-speed Ethernet interfaces are disabled. The following panels are unavailable and cannot be configured: PTP, NMOS, Receivers, and Senders.

Property	Description
Processing Mode	<p>Set the number of the XIP-3901-UDC-IF card's processing channels and the maximum supported resolution for each of those channels.</p> <p>Dual UHD/HD: The card supports two UHD or HD processing channels: UDC1 and UDC2. In this mode, processing channels UDC3, and UDC4 are unavailable.</p> <p>Quad HD: The card supports four HD processing channels: UDC1, UDC2, UDC3, and UDC4.</p>
Channel label UDC <i>n</i>	<p>Set a unique name to identify the receivers and senders for the UDC<i>n</i> processing channels. In the future, GV Orbit will read these values, allowing them to be readily identified within the control system.</p>
Card Label	<p>Set a unique name for this card. In the future, GV Orbit will read this value, allowing this card to be readily identified within the control system.</p>

For further information about how to configure remaining parameters in the Factory/Presets panel, see [Factory/Presets Panel](#), on page 249.

Network Panel

The Network panel is used to set the network configuration of the media and control Ethernet ports on the XIP-3901-UDC-IF.

The XIP-3901-UDC-IF's **Network** Panel configuration is the same as the XIP-3901-UDC-IP's **Network** Panel configuration, including all tabs; see [Network Panel](#), on page 125.

PTP Panel

To allow vertically accurate video frame synchronization, multicast Precision Timing Protocol (described in IEEE Standard 1588) is used to distribute time across a packet network. It is used on both media ports (ETH1 and ETH2) for BMCA redundancy. This supports Best Master Clock Algorithm (BMCA) as per IEEE-1588-2008. The XIP-3901-UDC-IF supports:

- SMPTE 2059-2 profile; locks the inputs and outputs on PTP
- AES-67 profiles
- Automatic one-step and two-step synchronization mode
- End-to-End Delay mechanism
- Multicast PTP only

This panel is available when the card's **Operating Mode** in the **Factory Presets** panel is set to the **SDI and IP Hybrid** option. See [Setting the Card's Operating Mode](#), on page 180 for more information.

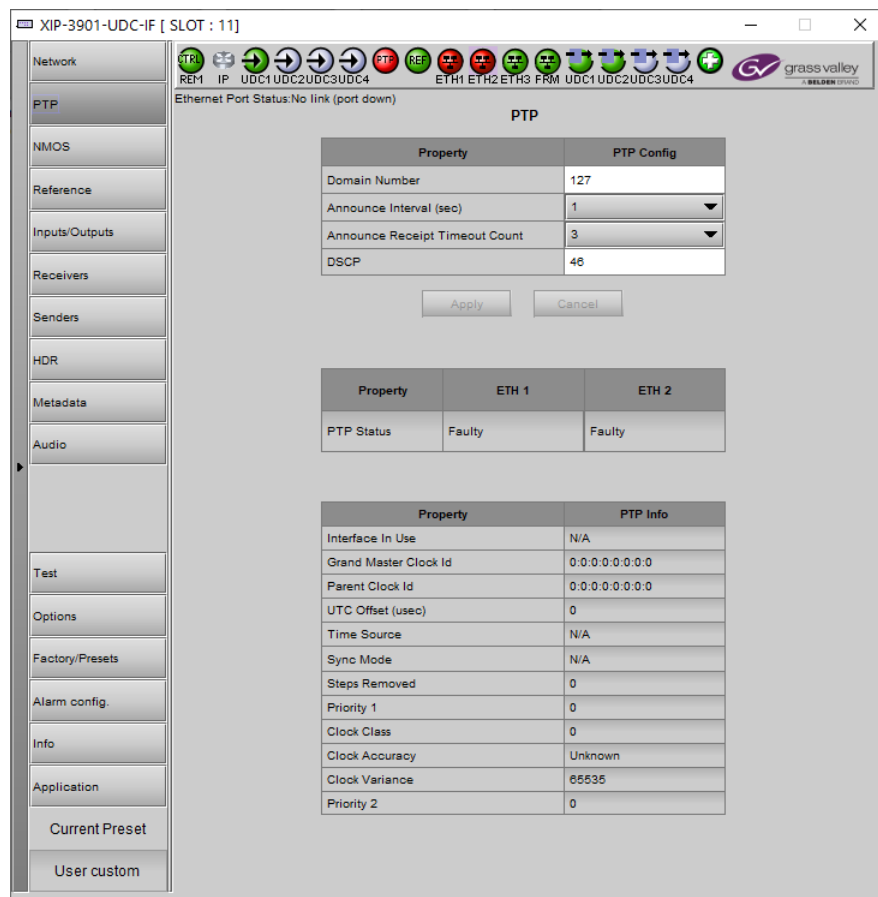

Fig. 9-2: PTP Panel

Property	Description
Domain Number	Specify the PTP Domain Number the card is to use to synchronize its clock. A domain is an interacting set of clocks that synchronize to one another using PTP. Clocks are assigned to a domain by virtue of the contents of the Subdomain name or the domain Number (IEEE 1588-2008) fields in PTP messages they receive or generate. The range is 0 to 127. The default value is 127.
Announce Interval	Specify the Announce message interval used by the parent clock (Boundary clock). Announce Interval range is: 0.125, 0.250, 0.500, 1, 2, 4, 8, 16 seconds. The default value is 0.125 second.
Announce Receipt Timeout Count	Specify the Announce Receipt Timeout used by the parent Boundary clock. The Announce Receipt Timeout range is 2 to 10 seconds. The default value is 3 seconds.
DSCP	Sets the quality of service priority for outgoing PTP packets. The range is 0 to 63. The default value is 46.
PTP Status ETH1 & ETH2	Shows the status of the ETH interfaces. The possible values are: Faulty: The protocol's fault state. Listening: The port is waiting for the announceReceiptTimeout to expire or to receive an Announce message from a master. Uncalibrated: One or more master ports have been detected in the domain. Slave: The port is synchronized to the selected master port.
Interface In Use	Shows the interface that is currently receiving PTP (ETH1, ETH2).
Grand Master ID	Shows the Grand Master's ID (for example, Tektronix).
Parent Master ID	Shows the Boundary clock's ID (Switch ID).
UTC Offset (sec)	Shows the current time offset between UTC and PTP. This value can change. The possible range is -32768 to 32767.
Time Source	Shows the source of time used by the grandmaster clock. The possible values are Atomic Clock, GPS, Terrestrial Radio, PTP, NTP, Hand Set, Other, Internal Oscillator.
Sync mode	Shows the Sync Mode from the Grand Master. A boundary clock cannot have a different setting. The possible values are One Step, Two Step.
Priority 1	Shows the first priority. This is used in the execution of the Best Master Clock Algorithm (BCMA). The Priority (1 or 2) with the lowest value will be used as the clock reference. The possible values are 0 to 255.
Clock Class	Shows the clockClass attribute of an ordinary or boundary clock. This denotes the traceability of the time or frequency distributed by the grandmaster clock. The possible values are 0 to 255. For example, 6 = GPS, 99 = free run.
Clock Accuracy	Shows the clock's accuracy range with respect to UTC.
Clock Variance	Shows the calculated jitter and wander of the clock's oscillator over a Sync message interval.
Priority 2	Shows the second priority. This is used in the execution of the Best Master Clock Algorithm (BCMA). The possible values are 0 to 255.

NMOS Panel

XIP-3901-UDC-IF supports Networked Media Open Specifications (NMOS) AMWA IS-04 for device discovery and registration and IS-05 for connection management. Furthermore, it supports AMWA BCP-002 recommendations for Grouping NMOS Resources.

This panel is available when the card's **Operating Mode** in the **Factory Presets** panel is set to the **SDI and IP Hybrid** option. See [Setting the Card's Operating Mode](#), on page 180 for more information.

XIP-3901-UDC-IF relies on an external NMOS registry that is used to register NMOS devices. You must point XIP-3901-UDC-IF to this external NMOS registry.

PREREQUISITE: A working NMOS registry service must be available on the network.

When the **Dual UHD/HD** option for the **Operating Mode** has been selected, certain configuration parameters related to **UDC3** and **UDC4** become unavailable. See [Factory/Presets Panel](#), on page 249.

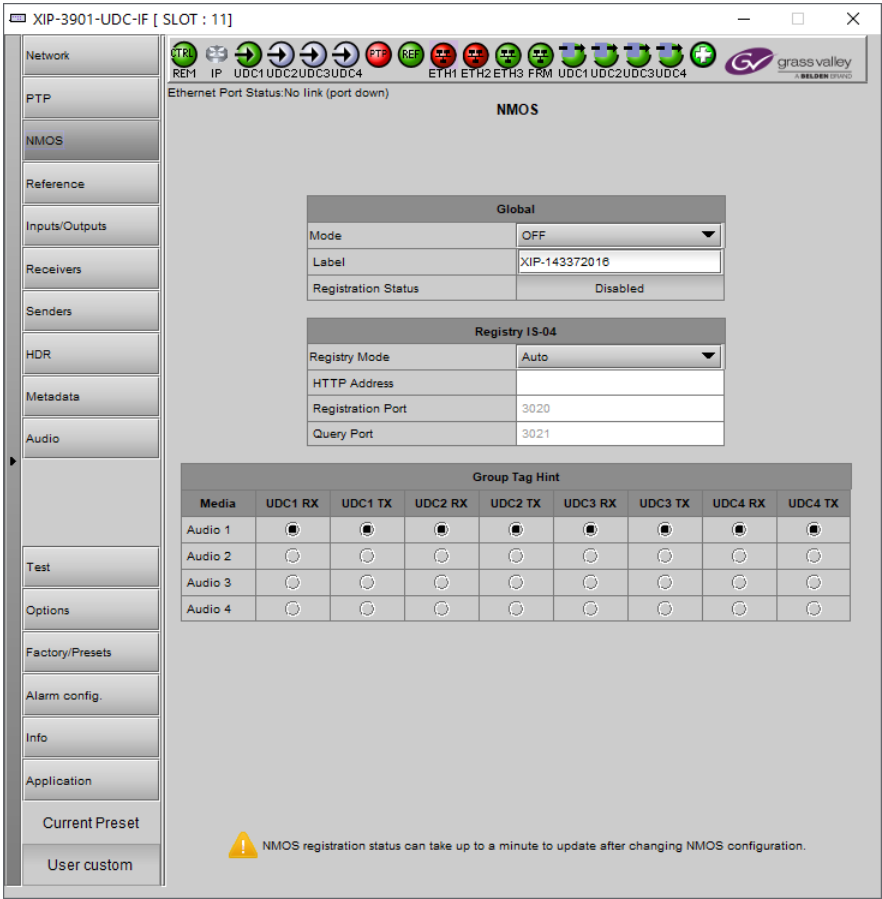

Fig. 9-3: NMOS Panel

Property	Description
Mode	Set the NMOS mode: IS-04: enable the Networked Media Open Specifications (NMOS) IS-04 v1.2 or higher for device discovery and registration. All senders will publish and update SDP file, but receivers can't be updated. IS-04 & IS-05: enable the NMOS IS-04 for device discovery and registration and IS-05 for connection management. All senders will publish and update an SDP File and receivers will accept routing request and process the received SDP file. OFF: disable NMOS. This eliminates the RED status when NMOS IS-04 is not used. This is the default.
Label	Set the identifier by which this XIP-3901-UDC-IP card will be known in the NMOS registry, and by extension, to other NMOS devices using this NMOS registry.
Registration Status	Shows if the card has successfully registered itself in the NMOS registry. Green: the card has successfully registered itself with the NMOS registry. Red: the card is not yet registered with the NMOS registry. Grey: NMOS is disabled (Mode is OFF).
Registry IS-04, Registry Mode	Set the IS-04, Registry Mode: Auto: automatic discovery of the NMOS registry using DNS Service Discovery (DNS-SD), as described in AMWA IS-04 NMOS Discovery and Registration Specification v1.2. Static: manually specified NMOS registry values for address, registration port and query port. In this mode, by specifying a registry address in the same subnet as one of the interfaces, the interface will be used. However, when specifying an address in a different subnet, the first available interface will be used in the following order: FRM, ETH3, ETH1 , and then ETH2 . The default Registry Port value is 3210. The default Query Port value is 3211.
HTTP Address	Set the NMOS registry's IP Address when the Registry IS-04, Registry Mode is Static .
Registration Port	Set the NMOS registry's registration port number when the Registry IS-04, Registry Mode is Static .
Query Port	Set the NMOS registry's query port number when the Registry IS-04, Registry Mode is Static .
Group Tag Hint	Set which audio receiver/sender to include in the Group Hint Tag. By Default GV Convergent creates logical source/destination groups with only one audio stream. If you want to have more audio receivers in a source/destination group, you will have to create them manually in GV Convergent.

Reference Panel

This panel is used to select the reference to be used by the XIP-3901 to synchronize the SDI inputs. Each processing channel can be locked to an independent reference source. For example, one processing channel can operate at 50Hz while the other processing channel can operate at 59.96Hz.

When the **Dual UHD/HD** option for the **Operating Mode** has been selected, certain configuration parameters related to **UDC3** and **UDC4** become unavailable. See [Factory/Presets Panel](#), on page 249.



Fig. 9-4: Reference Panel

Property	Description
Reference Presence	The icons show the presence and status of the various reference sources. For the external reference, the format is shown in the External Format window. Gray: There is no carrier or the carrier is not valid. Yellow: The carrier is present and is valid but its format is not supported. Green: The carrier is present and is valid and its format is supported.
External Format	Shows the current external reference format. The following shows which reference formats are supported: NTSC: Supported PAL: Supported 1080i 59 Hz: Unsupported 1080i 50 Hz: Unsupported 720p 59 Hz: Unsupported 720p 50 Hz: Unsupported All tri-level (HD) syncs are not supported.

Property	Description
Selected Reference	Shows which source is selected as a reference for each channel. The icons show whether the channel is locked to its reference or not. Gray: Locked on input, but the reference is not available. Green: Locked. Red: Missing, invalid, unsupported, or the channel is not locked to the selected reference. Note: If the selected reference is missing, invalid or unsupported, the SDI output(s) will be inactive (no carrier).
Reference Source	Use the radio buttons to select from the following settings: Auto (default): This mode selects the first source detected in this order of priority: <ol style="list-style-type: none"> 1 PTP 2 External Reference input^a 3 URS 4 Input PTP: Selects the multicast Precision Timing Protocol (described in IEEE Standard 1588) signal from the network's Grandmaster clock. This is unavailable when the card's Operating Mode in the Factory Presets panel is set to the SDI Only option. See Setting the Card's Operating Mode , on page 180 for more information. External: Selects the signal connected to the rear panel REF IN connector. URS: Selects the Universal Reference Signal from the Densité frame's backplane. Input: Each processing channel will lock on its selected SDI input.

a. **NOTE:** If the External Reference is of a different rate than the channel's selected input/output rate, the Auto mechanism will select the next suitable option in the list; that is the **URS** or **Input**, when available, to lock the output signal.

Inputs/Outputs Panel

This panel is used to configure the SDI inputs and outputs, to adjust colorimetry, frame synchronization, Audio/video deglitcher, Video proc including: gain, offset, hue, horizontal and vertical picture enhancement during downconversion, RGB color corrector, and gamut legalization.

The Inputs/Outputs panel has two tabs (**UDC1** and **UDC2**) in Dual Mode and four tabs (**UDC1**, **UDC2**, **UDC3**, and **UDC4**) in Quad HD mode; one for each of the XIP-3901-UDC-IF's independent processing channels, depending the selected mode of operation. The configuration of the **UDC1**, **UDC2**, **UDC3**, and **UDC4** tabs is the same as the **UDC1** tab. Only the configuration of the **UDC1** tab is shown below.

When the **Dual UHD/HD** option for the **Operating Mode** has been selected, certain configuration parameters related to **UDC3** and **UDC4** become unavailable. See [Factory/Presets Panel](#), on page 249.

Config Tab

This panel allows you to configure the settings for one of the up / down converters.

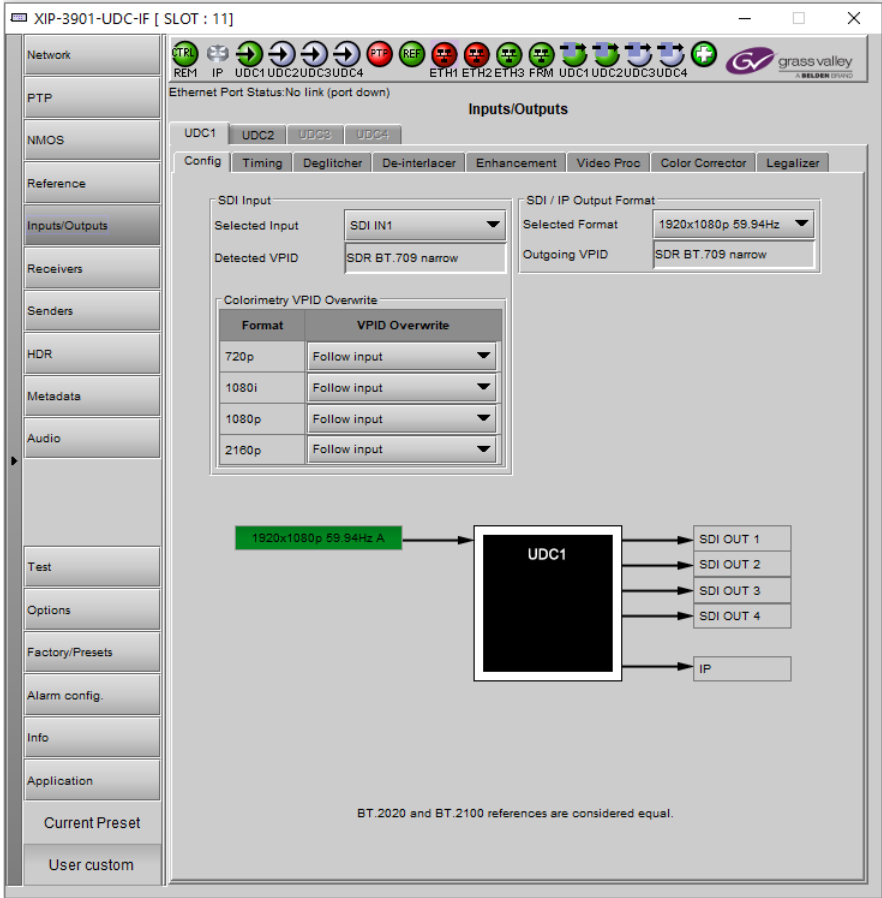

Fig. 9-5: Input/Output Config UDCn Tabs

Property	Description
Selected Input	<p>Select the card's SDI input to use for this processing channel. See Details of Rear Panel Connections, on page 51.</p> <p>When:</p> <ul style="list-style-type: none"> The Dual UHD/HD option for the Operating Mode has been selected: <ul style="list-style-type: none"> SDI IN1: Use this input as the SDI input for the current processing channel. SDI IN5: Use this input as the SDI input for the current processing channel. Default values are: UDC1 = SDI IN1, UDC2 = SDI IN5. The Quad HD option for the Operating Mode has been selected: <ul style="list-style-type: none"> SDI IN1: Use this input as the SDI input for the current processing channel. SDI IN5: Use this input as the SDI input for the current processing channel. SDI IN3: Use this input as the SDI input for the current processing channel. SDI IN7: Use this input as the SDI input for the current processing channel. Default values are: UDC1 = SDI IN1, UDC2 = SDI IN5, UDC3 = SDI IN3, and UDC4 = SDI IN7.

Property	Description
Detected VPID	Shows the SDI input Transfer Characteristic, Colorimetry, and Bit depth (Range) information contained within the Video Payload ID packet. Note: Unspecified (Payload ID missing) or incomplete (one of the three parts are missing), then the message Unknown is shown.
Selected Format	Set the output SDI stream's video format. Set the SDI and SMPTE 2110-20 output video format. <ul style="list-style-type: none"> • Auto (Follow Input) • 3840x2160p 59.94 Hz / 50 Hz^a • 1920x1080p 59.94 Hz / 50 Hz • 1920x1080i 59.94 Hz / 50 Hz • 1280x720p 59.94 Hz / 50 Hz The default value is Auto (Follow Input) for all precessing channels.
Outgoing VPID	Shows the SDI output Transfer Characteristic, Colorimetry, and Bit depth (Range) information contained within the Video Payload ID packet.
Colorimetry VPID overwrite	For each video format (720p, 1080i, 1080p, 2160p ^a), optionally: <ul style="list-style-type: none"> • Set the incoming video Payload ID should it be absent. • Override the incoming video Payload ID should it be incorrect. Set one of the following Video Payload ID (Transfer Characteristic, Colorimetry, and Bit depth) processing options that can be used to overwrite this input parameter: <ul style="list-style-type: none"> • Follow input: Follow the Video Payload ID (Transfer Characteristic, Colorimetry, and Bit depth) detected at the input. • SDR BT.709 narrow • SDR BT.2020 narrow • HLG BT.2020 narrow • PQ BT.2020 narrow • PQ BT.2020 full Default: <ul style="list-style-type: none"> • Value in overwrite mode for 720p and 1080i is SDR BT.709 narrow. • Value in overwrite mode for 1080p and 2160p^a is Follow input. Note: This application does not use an input SDP file.

a. This format is unavailable when the **Quad HD** option for the **Operating Mode** has been selected. See [Factory/Presets Panel](#), on page 249.

A diagram of the up/down conversion process is displayed underneath the settings. In the event of an error, more details are shown on the dashboard. For example, in Quad mode, a 2160p rates are flagged as unsupported.

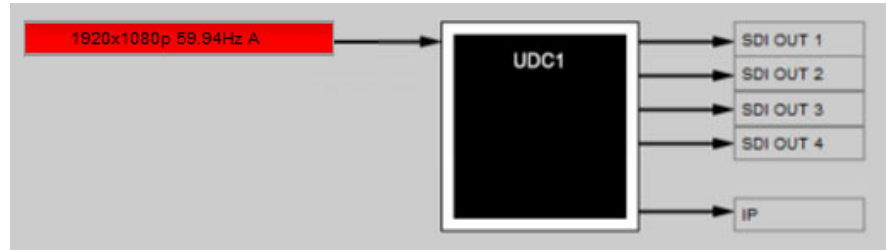

Fig. 9-6: Conversion Diagram Showing an Input in an Error State

The SDI input operating status are color coded as follows:

Status	Description
GREY	No SDI Carrier detected
GREEN	No error detected
RED	Video/TRS Error: Video TRS errors detected. Not supported: Detected video format is not supported.

Conversion diagram statuses are shown below.

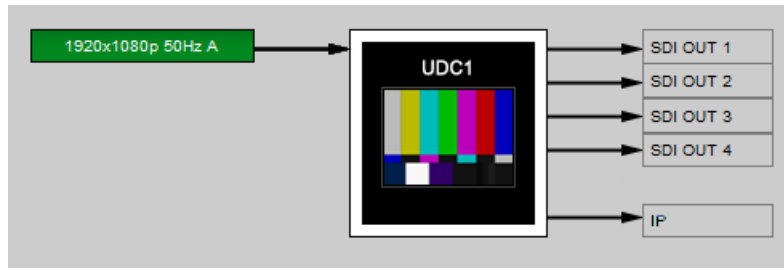

Fig. 9-7: Conversion Diagram Showing a Test Pattern Enabled on the Processing Channel

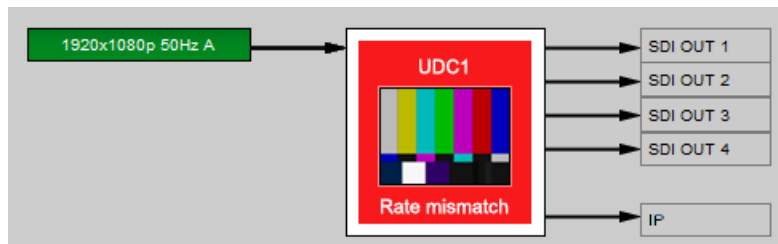

Fig. 9-8: Conversion Diagram Showing an Input and Output Rate Mismatch and Test Pattern Enabled on the Processing Channel

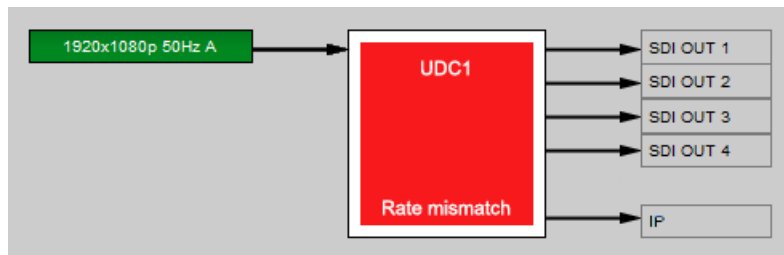

Fig. 9-9: Conversion Diagram Showing an Input and Output Rate Mismatch on the Processing Channel

Timing Tab

For each processing channel, you can adjust the timing relative to the reference. Depending the mode of operation, use the relevant slider or type a value into the data box to the right of the slider. SMPTE ST 2110 Metadata and audio streams will match the video delay set below.

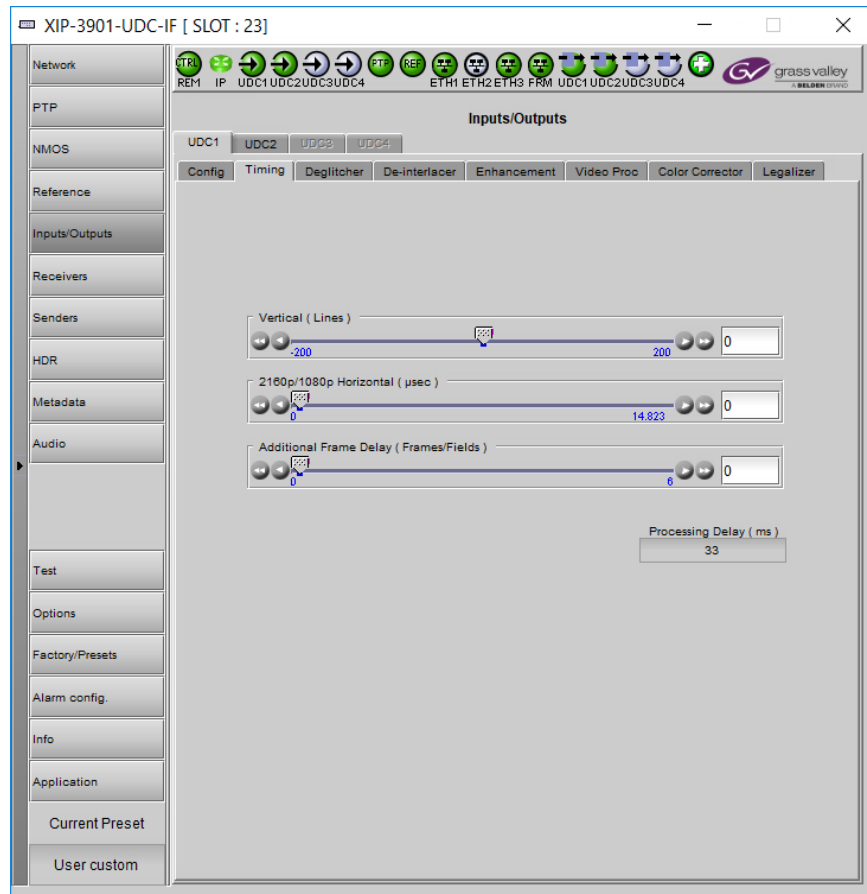

Fig. 9-10: Video I/O Timing Dual UHD Mode with output format set to 2160p or 1080p

The following adjustment sliders are available.

Adjustment	Range (50 Hz)	Range (59 Hz)	Description
Vertical (lines)	-200 to +200	-200 to +200	Vertical setting applies to all output formats.
3840x2160p (A) Horizontal (usec)	0 to 17.78	0 to 14.83	Horizontal settings are specific to individual output formats.
1920x1080p (A) Horizontal (usec)	0 to 17.78	0 to 14.83	
1920x1080i Horizontal (usec)	0 to 35.56	0 to 29.66	
1280x720p Horizontal (usec)	0 to 26.67	0 to 22.24	

The XIP-3911 and XIP-3901 has an integrated frame sync that supports synchronous and asynchronous SDI input signals. The input signals will be synchronized and realigned to either the URS or External Reference.

The frame sync behaves like a frame buffer. It also supports frame skips/repeats in the case of an asynchronous SDI input. When an input error occurs, it freezes to the last valid field/frame.

Ref	Signal	SDI Input	SDI Output	Skip / Repeat Period	Freeze on Input Error
Input	Video / Audio/ Metadata	All	All	Not applicable	Not applicable
Studio Black / URS / PTP	Video	1080i	All	2 Fields	Last valid field
		12G / 1080p / 720p	All	1 Frame	Last valid frame
	Audio	PCM	Not applicable	Tracking during 15 seconds per frame	Muted
		Non-PCM	Not applicable	Instant catch-up	Muted
Metadata	All	Not applicable	Lost when skipped, duplicated when repeated	Blanked	

Processing Delay

The display below provides information on the pass-through system processing delay in milliseconds (ms) for each channel to allow the management of a systems processing delay.



The following tables provide information on the on the pass-through system processing delay depending the mode of operation and assumes Horizontal and vertical timing controls are at default settings (0).

59 Hz formats:

Ref	SDI Input	Processing Delay		
		Asynchronous Inputs		Synchronous and Phase-Aligned Inputs (ms)
		Minimum (ms)	Maximum (ms)	
Input	All formats	-	-	33
Studio black/URS/PTP	2160p / 1080p / 720p	8.3	25	17
	1080i	25	58.4	33

50 Hz formats:

Ref	SDI Input	Processing Delay		
		Asynchronous Inputs		Synchronous and Phase-Aligned Inputs (ms)
		Minimum (ms)	Maximum (ms)	
Input	All formats	-	-	40
Studio black/URS/PTP	2160p / 1080p / 720p	8.3	28.3	20
	1080i	28.3	68.3	40

Bulk Video and Audio Delay

The control below allows the user to add additional bulk delay (video & audio) of up to 6 frames in steps of 1 frame for progressive sources or 6 fields in steps of 2 fields for interlaced sources into the system if required, by default no added delay is introduced.

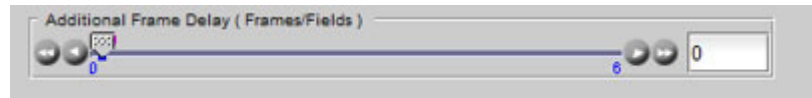

Adjustment	Range (50 Hz)	Range (59 Hz)	Description
Additional Frame Delay	0 to 6	0 to 6	Manage frames for progressive outputs and fields for interlaced format. With interlaced formats, the slider jumps by steps of 2 fields.

Deglitcher Tab

For each processing channel tab **UDC_n**, select the appropriate deglitcher mode (ON or OFF) using the pulldown menu.

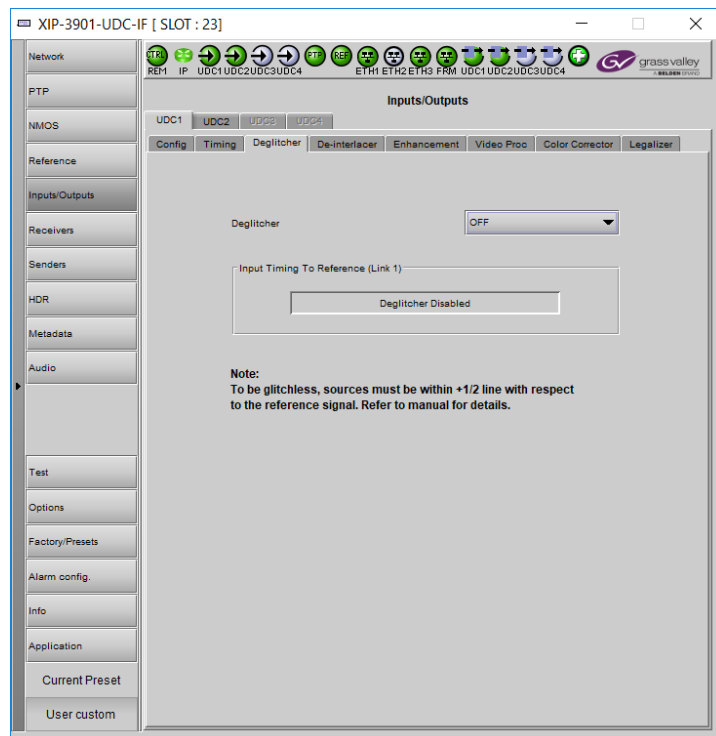

Fig. 9-11: Deglitcher Tab

When the deglitcher is enabled, the card supports a hotswitch between upstream signals without producing a freeze on the frame sync, and without producing artifacts on the output.

The deglitcher must be disabled when the input is asynchronous to the reference. Otherwise, it will create audio and video glitches at the output.

For this mode to function correctly, the following requirements must be met:

- The two inputs must be synchronized to the reference
- They must be phased within one line of each other
- They must be phased to within $\pm \frac{1}{2}$ line of the HREF of the reference signal

The offset from the VREF can be variable, but a distance of greater than 10 lines could create an artifact in the active video. If the two signals are more than one line apart, a vertical jump will occur at the moment of switching that is proportional to the number of vertical lines of offset between the two signals. This will last for only one frame. For more information about using clean switch regions to perform glitch-free switches, see [Clean Switch Regions and Examples](#), on page 109.

The Input Timing to Reference box reports any difference in timing between the input and reference when the transition occurs. When the deglitcher is disabled, it will display "Deglitcher Disabled". When the deglitcher is enabled, it can display one of the following error messages in red:

- **Missing Reference:** The External or URS reference source is missing.
- **Locked on Input:** The reference source is set to Input.
- **Video Error:** There is an error with the input.

De-interlacer Tab

Each processing channel has its own de-interlacer used during interlaced sources. The Film Mode and Video Over Film settings can either be set to **On** or **Off**. By default, both are set to **On** for optimal performance.

The XIP-3901-UDC-IF's **Input/Output** Panel, **De-interlacer** tab configuration is the same as the XIP-3901-UDC-IP's **Video** Panel, **De-interlacer** tab configuration; see [De-interlacer Tab](#), on page 150.

Enhancement Tab

The detail enhancer allows you to apply a level of enhancement to the signal to regain lost detail or to simply create a sharper image. Horizontal and Vertical slide controllers allow you to adjust the magnitude of the enhancer to be set both horizontal and vertical directions. These controls only work after down-scaling of video resolution from UHD to 3G/HD signal formats. For example, 2160p to 1080p or 1080i for instance.

The **Mode** Control allows you to select the particular luminance frequency band to be enhanced – Medium Frequency or High frequency.

Horizontal and Vertical Enhancer Controls are usually used with restraint by only making minor adjustments. The optimum settings of the Horizontal and Vertical Detail Enhancer are dependent on the source. The amount of aliasing on the output will be dependent upon the higher frequencies present in the source content and a balance would need to be established between aliasing artifacts, picture sharpness, and the amount of detail. For example, if the enhancers are configured to allow more high frequency content through, this will have the benefit of making the output pictures appear sharper, but the effect can come at the cost of introducing aliasing to the image.



Fig. 9-12: Video I/O Enhancement

Property	Description
MPEG Preprocessor Mode	Used to control the sharpness of edges and to control the presence of ringing artifacts during scaling on the output: OFF (default): Ringer Removal is Enabled; filters ringing from passing to output. ON : Ringer Removal is Disabled; allows some ringing to pass to output. Set to ON only for scenarios with content that is difficult to be encoded at a lower bit rate on a downstream MPEG Encoder, otherwise set to OFF. This setting should be used alongside the detail H&V enhancer in conjunction with the output filtering tools were applicable to strike a balance between increasing the details and the sharpness of edges without allowing too much high frequency content through that could stress downstream MPEG encoders.
Enable	Set to enable vertical and horizontal enhancement adjustment. The below settings can be adjusted, but they will only be applied when Enable is set. Pass-through when cleared.
Mode	Select the particular frequency band to be enhanced: High : Boost the high frequency content of the input signal. Medium : Boost the medium frequency content of the input signal.
Horizontal Detail Enhancer (UHD to 3G/HD)	Set the amount of horizontal detail enhancement to be applied to the video signal. TIP: Use restraint and only make minor adjustments.
Vertical Detail Enhancer (UHD to 3G/HD)	Set the amount of vertical detail enhancement to be applied to the video signal. The Vertical Enhancer adjustment ranges from a <i>soft</i> range (negative values) to a max intensity <i>sharper</i> (positive values): It is not usual practice to want to make pictures <i>softer</i> than the source. However, in some circumstances this is a requirement. For example, when an ultra-sharp high definition content is to be down-converted, the high frequency content of the source may cause aliasing in the downconverted output. By <i>softening</i> the processed pictures, the aliasing can be reduced or eliminated. TIP: Use restraint and only make minor adjustments.
Down Convert Image - 1080i Output Filtering	Set the amount of filtering to be applied to the video signal during 1080i down conversion. In the positive range applies more filtering and hence makes the picture softer by removing more high frequency content to make edges appear smoother to the viewer. In the negative range applies less filtering and hence makes the picture sharper by allowing more high frequencies to pass through to the output and hence this can make aliasing more visible. 2160p to 1080i : Set the amount of filtering to be applied to 2160p to 1080i conversion. 1080p to 1080i : Set the amount of filtering to be applied to 1080p to 1080i conversion.
Reset Defaults	Click to revert all controls to their default settings.

Video Proc Tab

The Video Proc controls allow you to apply a correction to the individual signal components of the Y'CrCb color space. This follows the input colorimetry of the one selected in the HDR panel.

The XIP-3901-UDC-IF's **Input/Output** Panel, **Video Proc** tab configuration is the same as the XIP-3901-UDC-IP's **Video** Panel, **Video Proc** tab configuration; see [Video Proc Tab](#), on page 153.

Color Corrector Tab

The Color Corrector controls allow you to apply correction to the individual primary RGB channels.

The XIP-3901-UDC-IF's **Input/Output** Panel, **Color Corrector** tab configuration is the same as the XIP-3901-UDC-IP's **Video** Panel, **Color Corrector** tab configuration; see [Color Corrector Tab](#), on page 154.

Legalizer Tab

The Legalizer ensures that the output video stays within the legal RGB gamut limit, making it suitable for the broadcast signal chain.

The XIP-3901-UDC-IF's **Input/Output** Panel, **Legalizer** tab configuration is the same as the XIP-3901-UDC-IP's **Video** Panel, **Legalizer** tab configuration; see [Legalizer Tab](#), on page 155.

Receivers Panel

When the **XIP-3901-UDC-AUD** option is installed, it adds four SMPTE ST 2110-30/31 IP audio input streams per processing channel, and provides 256 channel audio processors with level, delay, and up/down mixing. To install the **XIP-3901-UDC-AUD** option, see [Options Panel](#), on page 176. See also [Optional XIP-3901-UDC-IF v4.0 Application Audio processing, Down/Up Mix, Shuffling](#), on page 31 for the feature overview for this licensed option.

The **Receivers** panel has two tabs (**UDC1** and **UDC2**) in Dual Mode and four tabs (**UDC1**, **UDC2**, **UDC3**, and **UDC4**) in Quad HD mode; one for each of the XIP-3901-UDC-IF's independent processing channels, depending the selected mode of operation. The configuration of the **UDC1**, **UDC2**, **UDC3**, and **UDC4** tabs is the same as the **UDC1** tab. Only the configuration of the **UDC1** tab is shown below.

This panel is available when the card's **Operating Mode** in the **Factory Presets** panel is set to the **SDI and IP Hybrid** option. When the **Dual UHD/HD** option for the **Operating Mode** has been selected, the **UDC3** and **UDC4** tabs become unavailable. See [Setting the Card's Operating Mode](#), on page 180 for more information.

Config Tab

This tab allows you to configure the expected source media's audio channels, stream address, port, and IGMPv3 source. The receivers are ST 2110-30 (**Audio 1**, **Audio 2**, **Audio 3**, and **Audio 4**). All audio receivers can join streams of up to 64 audio channels. Audio 1 is the only one that can process all 64 audio channels. Audio 2 to 4 will process audio channels 1 to 16 and ignore audio channels 17 to 64.

Statuses confirm that the RTP stream is successfully streaming.



Fig. 9-13: Receivers Config Tab

Property	Description
Audio	<p>Type: Use the pull-down to set the audio source stream's type for streams Audio 1 to Audio 4.</p> <ul style="list-style-type: none"> • Type SMPTE ST 2110-30: for PCM linear audio (AES67 compatible) • Type SMPTE ST 2110-31: for transparent transport of non-linear audio and data formats: provides bit-transparent AES3 over IP <p>Profile: Use the pull-down to set the audio profile for streams Audio 1 to Audio 4. Audio receivers support Level C as per SMPTE 2110-30/31: 48kHz stream from 1 to 8 channels (1 to 4 for SMPTE 2110-31) at packet times of 1ms and 1 to 64 channels (1 to 60 for SMPTE 2110-31) at packet time of 125us. These settings can also be managed by external NMOS control. See NMOS Panel, on page 133.</p>
Master	<p>Set to enable a media receiver. This manages the Join/Release of both the primary and secondary streams. These settings can also be managed by external NMOS control. See NMOS Panel, on page 133.</p>
Media	<p>Shows the stream type. The background shows the current media status:</p> <p>Green: no error Red: error Grey: inactive</p>

Property	Description
RTP Stream	Set to enable each stream receiver individually (primary and secondary).
Stream	Shows the primary (ETH1) and secondary (ETH2) stream receiver status: Green: no error Red: error Grey: inactive
IGMPv3 Source	Set the source from which to receive multicast streams. With this protocol, the card deals with a switch to subscribe to one or many streams that are coming from different sources. Both iGMPv3 and iGMPv2 protocols are supported. Set this to 0.0.0.0 if iGMP source is not used. The source range is 0.0.0.0 to 255.255.255.255. The default value is 0.0.0.0. These settings can also be managed by external NMOS control. See NMOS Panel , on page 133.
RX Stream Address	Set the IP address and UDP port number at which this card receives a specific stream. IP address 0.0.0.0 disables a receiver. The default UDP port values are: 10000 for all media receivers.
RX Stream Port	These settings can also be managed by external NMOS control. See NMOS Panel , on page 133.
SDP File	Click to show the last SDP file received through NMOS IS-05 since the last bootup. This window does not refresh automatically; you need to close and re-open the window to see an update. If the card has never received an SDP file since last its last bootup, the window will be empty.
Apply Cancel	When active, this applies or rejects your current changes made in this tab except for Audio type and Profile

Timing Tab

This tab allows you to view the network health of the stream's connection (link latency, receiver buffer level, and offset time).

Media	Stream	Link Latency (usec)	Buffer Level		Link Offset (usec)
			(usec)	(%)	
Audio 1	ETH1	125	375	0.14	770
	ETH2	0	0	0.00	0
Audio 2	ETH1	125	375	0.14	770
	ETH2	0	0	0.00	0
Audio 3	ETH1	125	375	0.14	770
	ETH2	0	0	0.00	0
Audio 4	ETH1	125	375	0.14	770
	ETH2	0	0	0.00	0

Property	Value
Syntonized Audio 1	<input type="checkbox"/>
Syntonized Audio 2	<input type="checkbox"/>
Syntonized Audio 3	<input type="checkbox"/>
Syntonized Audio 4	<input type="checkbox"/>

Fig. 9-14: Receivers Timing Tab

Property	Description
Media	Shows the stream type. The background shows the current media status: Green: No error Red: Error Grey: Inactive
Stream	Shows the primary (ETH1) and secondary (ETH2) stream receiver status: Green: No error Red: Error Grey: Inactive
Link Latency	Shows the time it takes for a packet to come from the source to the receiver. This measurement represents the difference between incoming RTP timestamp and PTP time before the receiver's buffer.

Property	Description
Buffer level	Shows the amount of preloaded data stored in the receiver that is ready for use in microseconds and in percentage. The current buffer level in microseconds shows the minimum latency required to receive a continuous stream. The current buffer level in percentage shows how much of the internal buffering is used to receive the current stream.
Link Offset	Shows the resulting link latency after being read out from receiver's buffer. This measurement is the difference between the packet RTP timestamp and the PTP time after the receiver's buffer and represents the total reception delay. Video, Metadata, and audio link offset depends on the selected Network Tolerance. Moreover, Audio link offset can also depend on the currently-selected Audio Mode.
Syntonized Audio 1 to 4	Set to ignore Audio RTP timestamps. Audio buffer reception is then fixed to 25%. Use these settings to manage audio streams that are not properly time stamped. Enable syntonize for audio 1 to 4 individually.

Redundancy Tab

This tab allows you to view the reception state regarding SMPTE ST 2022-7 redundancy. The primary and secondary streams, at the packet level, will work together in order to produce a valid resulting stream. To achieve redundancy, both streams need to be in range with respect to the receiver buffer. Adjustments can be done by applying a bigger Network Tolerance if need be (see [Timing Tab](#), on page 137). In the circumstance in which only one stream is successfully received, the resulting stream will be valid as well but without any active redundancy protection.

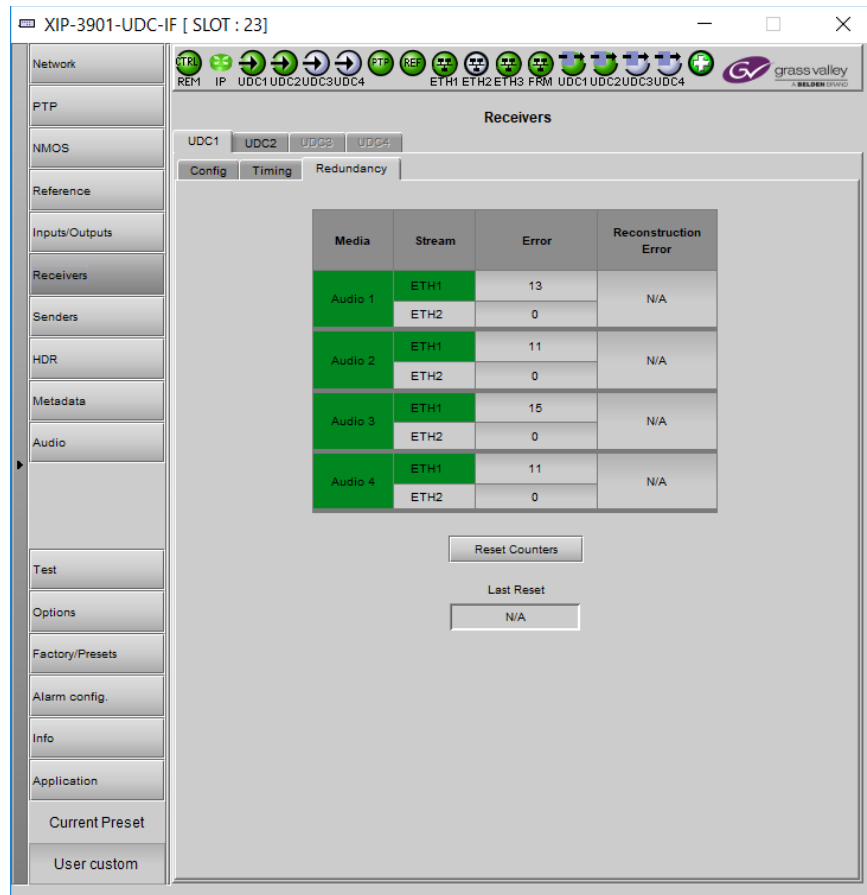

Fig. 9-15: Receivers Redundancy Tab

Property	Description
Media	The background shows the current media status: Green: No error Red: Error Grey: Inactive
Stream	Shows the primary (ETH1) and secondary (ETH2) stream receiver status: Green: No error Red: Error Grey: Inactive

Property	Description
Error	Shows the number of packets in error that will required SMPTE 2022-7 reconstruction for each Ethernet port.
Reconstruction Error	Shows if the redundant stream was successful at maintaining signal integrity for the previous 5 seconds, when primary (ETH1) and secondary (ETH2) ports are enabled.
Reset Counters	Clears the number of errors shown above. When Reset is clicked, the current date and time is shown as a record of how long the error counters have been running since the last reset.

Senders Panel

The **Senders** panel has five tabs (**UDC1**, **UDC2**, **UDC3**, **UDC4**, and **Advanced**); **UDC1** to **UDC4** are for each of XIP-3901-UDC-IF's independent processing channels. These tabs configure the SMPTE ST 2110 outputs. The **Advanced** tab allows you to configure the outgoing payload type and DSCP priority.

This panel is available when the card's **Operating Mode** in the **Factory Presets** panel is set to the **SDI and IP Hybrid** option. When the **Dual UHD/HD** option for the **Operating Mode** has been selected, the **UDC3** and **UDC4** tabs become unavailable. See [Setting the Card's Operating Mode](#), on page 180 for more information.

UDCn Tabs

These tabs allow you to configure the destination media's video format, audio channels, and the SMPTE ST 2110 output stream's IP addresses and port numbers. The configuration of all **UDCn** tabs are the same as the **UDC1** tab. Only the configuration of the **UDC1** tab is shown below.

Each processing channel (**UDCn**) can:

- Send one SMPTE 2110-20 video streams (**Video 1**).
 - When the **Dual UHD/HD** option for the **Operating Mode** has been selected, the card supports two UHD or HD processing channels: **UDC1** and **UDC2**. In this mode, processing channels **UDC3**, and **UDC4** are unavailable.
 - When the **Quad HD** option for the **Operating Mode** has been selected, the card supports four HD processing channels: **UDC1**, **UDC2**, **UDC3**, and **UDC4**.

See [Setting the Card's Operating Mode](#), on page 180 for more information.

- Send full ancillary space on one SMPTE 2110-40 metadata stream (**Meta 1**)
- Send 4 audio streams (**Audio 1** to **Audio 4**)
 - **Audio 1** can send up to 64 processed audio channels.
 - **Audio 2** to **Audio 4** can send up to 64 audio channels, but only audio channels 1 to 16 are processed audio channels. Audio channels 17 to 64 will contain silence.

Statuses confirm that the RTP stream is successfully streaming.

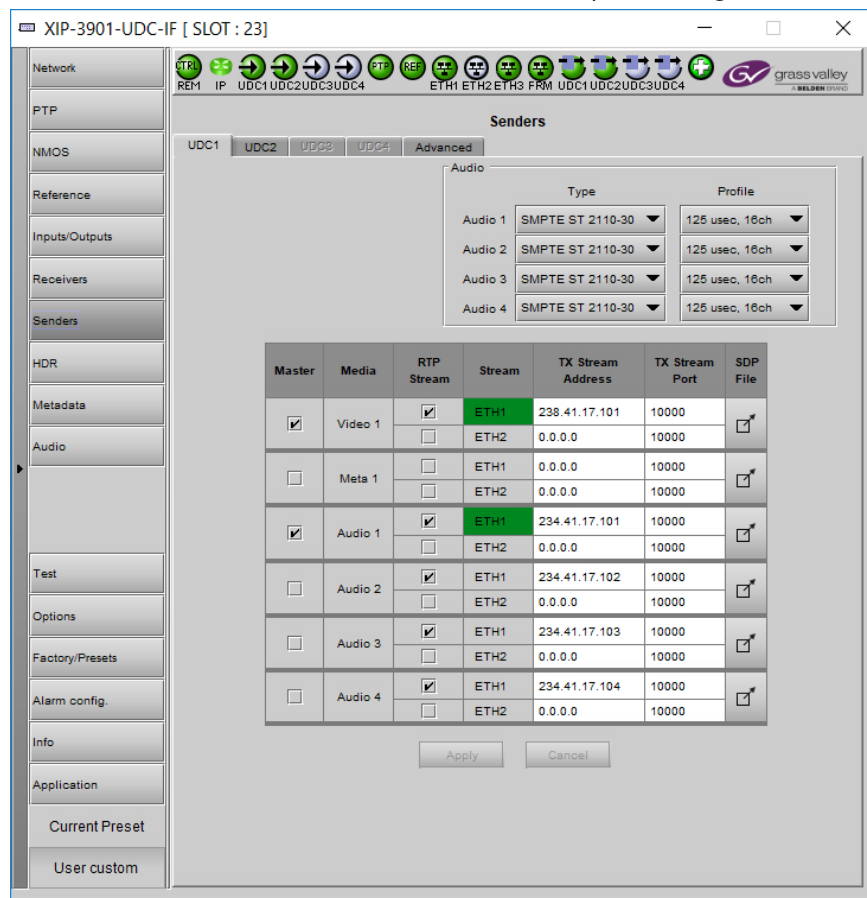

Fig. 9-16: Senders UDCn Tabs

Property	Description
Audio	<p>Type: Use the pull-down to set the audio stream's type for streams Audio 1 to Audio 4.</p> <ul style="list-style-type: none"> • Type SMPTE ST 2110-30: for PCM linear audio (AES67 compatible) • Type SMPTE ST 2110-31: for transparent transport of non-linear audio and data formats. Provides bit-transparent AES3 over IP. <p>Profile: Use the pull-down to set audio profile for streams Audio 1 to Audio 4. Audio senders support Level C as per SMPTE 2110-30/31: 48kHz stream from 1 to 8 channels (1 to 4 for SMPTE 2110-31) at packet times of 1ms and 1 to 64 channels (1 to 60 for SMPTE 2110-31) at packet time of 125us.</p> <p>For Audio 2 to Audio 4, only the first 16 channels will carry active audio and channels 17-64 will carry silence.</p> <p>These settings can also be managed by external NMOS control. See NMOS Panel, on page 133.</p>
Master	Set to enable a media sender. This manages both the primary and secondary streams. This can also be managed by external NMOS control. See NMOS Panel , on page 133.
Media	Shows the stream type.

Property	Description
RTP Stream	Set to enable a media stream sender for primary and secondary. This can also be managed by external NMOS control. See NMOS Panel , on page 133.
Stream	Shows the primary (ETH1) and secondary (ETH2) streaming status: Green: streaming Red: not streaming Grey: not active
TX Stream Address	Set the IP address and UDP port number of the outgoing stream. IP address 0.0.0.0 disables a sender. The default UDP port values are 10000.
TX Stream Port	Address & UDP port can also be managed by external NMOS control. See NMOS Panel , on page 133.
SDP File	Click to show the last SDP file transmitted through NMOS since the last bootup. This window does not refresh automatically; you need to close and re-open the window to see an update. If the card has never received an SDP file since its last bootup, the window will be empty.
Apply Cancel	When active, this applies or rejects your current changes made in this tab except for Audio Type and Audio Profile

Advanced Tab

This tab allows you to configure the outgoing payload type and DSCP priority for SMPTE 2110-20 (**Video**), SMPTE 2110-40 (**Meta 1**) and SMPTE 2110-30/31 (**Audio 1 to Audio 4**). These settings apply to all **UDC_n** tabs.

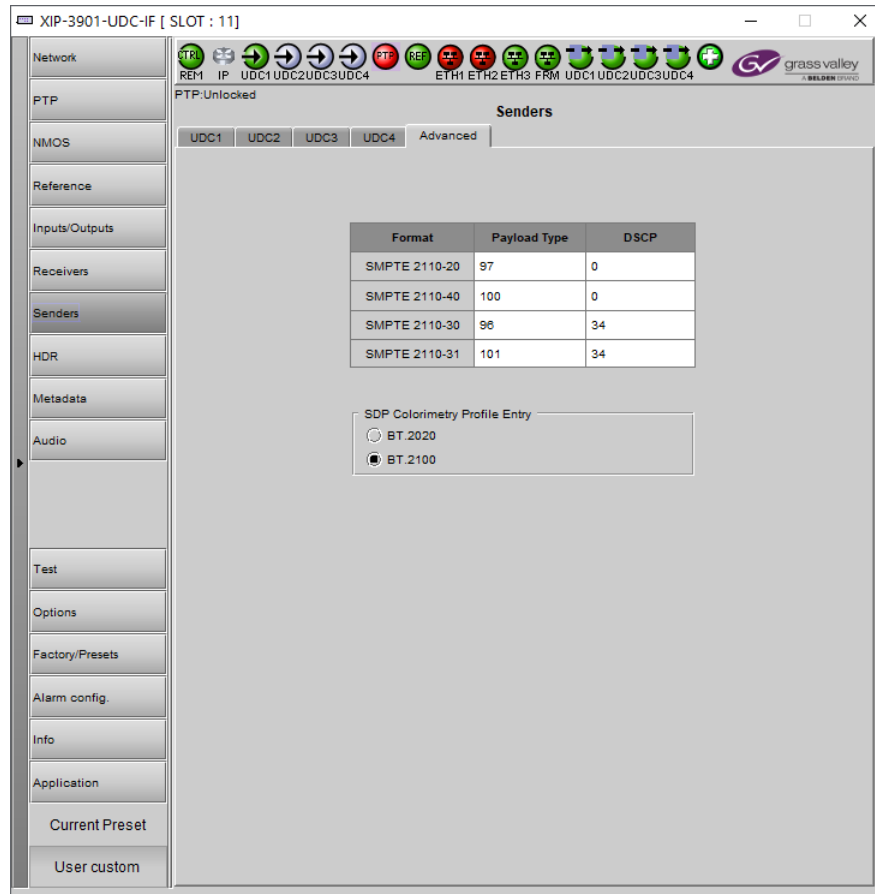

Fig. 9-17: Senders Advanced Tab

Property	Description
Payload Type	<p>Sets the RTP Payload ID value of outgoing video, metadata and audio streams. Possible range: 0 to 128 The default value are:</p> <ul style="list-style-type: none"> • 97 for SMPTE 2110-20 (Video) • 100 for SMPTE 2110-40 (Metadata) • 96 for SMPTE 2110-30 (audio) • 101 for SMPTE 2110-31 (audio)

Property	Description
DSCP	<p>Sets the quality of service priority on the network for the outgoing video, metadata, and audio streams. The range is 0 to 63.</p> <p>The default values are:</p> <ul style="list-style-type: none">• 0 for SMPTE 2110-20 (Video)• 0 for SMPTE 2110-40 (Metadata)• 34 for SMPTE 2110-30 (audio)• 34 for SMPTE 2110-31 (audio)
SDP colorimetry profile entry	<p>Set your preference for which terminology the card will use for the <i>colorimetry</i> attribute in the outgoing SDP files; either BT.2020 or BT.2100 terminology. This setting is common to all Senders. You can only overwrite the selected value when the output colorimetry is already BT.2020 or BT.2100.</p>

HDR Panel

The HDR panel has five tabs (**UDC1**, **UDC2**, **UDC3**, **UDC4**, and **Custom LUTs**); **UDC1** to **UDC4** are for each of XIP-3901-UDC-IF's independent processing channels. The configuration of all **UDCn** tabs are the same as the **UDC1** tab. Only the configuration of the **UDC1** tab is shown below.

When the **Dual UHD/HD** option for the **Operating Mode** has been selected, the **UDC3** and **UDC4** tabs become unavailable. See [Setting the Card's Operating Mode](#), on page 180 for more information.

UDCn Tabs

Grass Valley offers its own HDR processing alongside the support of industry recognized LUTs, for example, BBC LUTs and NBCU LUTs which are already preloaded and ready to use or you can load additional Custom LUTs onto the card when necessary.

Furthermore, the incoming Video Payload ID (Transfer Characteristic, Colorimetry, and Bit depth) can be corrected without applying any HDR conversion. Use the radio button to select the desired processing. Grass Valley HDR processing is selected by default.

Grass Valley color space conversion internal LUT's, for example, BT.709 to BT2020 and BT.2020 to BT.709 are always available. Other video processing settings can be enabled for each channel by activating the **XIP-3901-UDC-HDR** option. See [Options Panel](#), on page 176 for details about how to activate card options.



Fig. 9-18: HDR UDCn Tabs

Property	Description
Enable	Set to enable color space conversion and dynamic range conversion. When disabled, incoming color space and dynamic range are bypassed without processing. The Applied Conversion statuses will indicate “Bypass”. You can change the HDR processing setting values even if processing is disabled, but processing will not be performed. Processing is disabled by default.

Property	Description
Global table > Grass Valley LUTs	<p>Set the LUT to use for HDR processing. The following HDR processing setting are available as part of the Grass Valley LUTs:</p> <ul style="list-style-type: none"> • GV BT.709 to BT.2020 • GV BT.2020 to BT.709 • GV SDR BT.709 to HLG BT.2100 • GV HLG BT.2100 to SDR BT.709 • GV SDR BT.709 to PQ BT.2100 narrow • GV SDR BT.709 to PQ BT.2100 full • GV PQ BT.2100 narrow to SDR BT.709 • GV PQ BT.2100 full to SDR BT.709 • GV PQ BT.2100 narrow to HLG BT.2100 • GV HLG BT.2100 to PQ BT.2100 narrow • GV S-Log3/S-Gamut3 to BT.709 800% • GV S-Log3/S-Gamut3 to PQ BT.2100 narrow • GV S-Log3/S-Gamut3 to HLG BT.2100 <p>The configuration parameters for the Grass Valley LUTs are set in the Grass Valley LUTs table below. See below.</p>
Global table > Enterprise LUTs	<p>Set the LUT to use for HDR processing. The following HDR processing setting are available as part of the BBC / NBC LUTs:</p> <ul style="list-style-type: none"> • BBC SDR to HLG scene (4-1a - v1.5) • BBC SDR to HLG scene strict (4-2a - v1.5) • BBC SDR to HLG scene upmap (6-1a - v1.5) • BBC SDR to HLG scene upmap strict (6-2a - v1.5) • BBC SDR to HLG display (3c - v1.5) • BBC SDR to HLG display upmap (5c - v1.5) • BBC HLG to SDR scene (12-1c - v1.5) • BBC HLG to SDR scene strict (12-2c - v1.5) • BBC HLG to SDR display (8c - v1.5) • BBC HLG to SDR display harsh (9c - v1.5) • BBC PQ 1000 nits full range to HLG (1c - v1.5) • BBC PQ 1000 nits narrow range to HLG (1e - v1.5) • BBC PQ 4000 nits full range to HLG (2c - v1.5) • BBC PQ 4000 nits narrow range to HLG (2e - v1.5) • BBC HLG to PQ 1000 nits narrow range (7c - v1.5) • BBC S-Log3 100% scene to HLG (10a - v1.5) • BBC S-Log3 200% scene to HLG (11a - v1.5) • BBC Unity (13a - v1.5) • BBC SDR BT2020 to HLG Display Directmap (17c - v1.5) • BBC SDR BT2020 to HLG Display Upmap (18c - v1.5) • BBC HLG BT2020 to HLG BT2020 Display Hard Clip (19c - v1.5) • BBC sRGB BT709 to HLG BT2020 (20c - v1.5) • NBCU SDR to HLG display upmap (SDR2HLG_DL_v1.1) • NBCU SDR to HLG scene tonemap (SDR2HLG_SL_v1) • NBCU HLG to SDR display downmap (HLG2SDR_DL_v1.1) • NBCU SDR to PQ display upmap (SDR2PQ_DL_v1) • NBCU PQ to SDR display downmap (PQ2SDR_DL_v1) • MovieLabs PQ 4K to HLG 1K Max RGB • NBCU HLG 1K to PQ transcode (HLG10002PQ_v1)
Global table > Custom LUTs	<p>Set the LUT to use for HDR processing. You can pre-load up to 8 custom HDR conversions on the card. These are configured in the Custom LUTS tab. The LUT selection shows the filename for each LUT that was loaded onto the card.</p>

Property	Description
Global table > Auto	<p>Set to program up to six actions that execute predefined HDR conversions driven by the Video Payload ID data (Transfer Characteristic, Colorimetry, and Bit depth):</p> <ul style="list-style-type: none"> • SDR BT.709 narrow input • SDR BT.2020 narrow input • HLG BT.2020 narrow input • PQ BT.2020 narrow input • PQ BT.2020 full input • Unknown <p>The automatic HDR processing methods are set under Auto. See below.</p> <p>The HDR processor will detect and identify the incoming HDR type regardless of the operation mode selected in the Global table (Grass Valley LUTs, Enterprise LUTs, Custom LUTs, and Auto).</p> <p>The current HDR type is identified by a P symbol in the Auto table. When Auto operation mode is selected, the conversion that is selected for the detected HDR type will be applied.</p> <p>For each HDR type, there is a list of possible conversions. When Auto is selected, the current conversion is displayed in the Global table to the right of the Auto radio button.</p>
Grass Valley LUTs table > HLG BT.2100 to SDR – Input HDR Ref White (nits)	<p>Set the <i>reference white</i> luminance level in nits that will become 100% white in the SDR output. The value range must be between 100 and 1000 nits. The default value is 203 nits. This parameter is only applied when the Grass Valley HLG BT.2100 to SDR LUT is selected.</p>
Grass Valley LUTs table > SDR to HLG BT.2100 – Output HDR Ref White (nits)	<p>Set the <i>reference white</i> luminance level in nits for the HDR output that represents 100% white in the SDR input. The value range must be between 100 and 1000 nits. The default value is 203 nits. This parameter is only applied when the Grass Valley SDR to HLG BT.2100 LUT is selected.</p>
Grass Valley LUTs table > PQ BT.2100 to SDR – Input HDR Ref White (nits)	<p>Set the <i>reference white</i> luminance level in nits that will become 100% white in the SDR output. The value range must be between 100 and 1000 nits. The default value is 203 nits. This parameter is only applied when the Grass Valley PQ BT.2100 to SDR is selected.</p>
Grass Valley LUTs table > SDR to PQ BT.2100 – Output HDR Ref White (nits)	<p>Set the <i>reference white</i> luminance level in nits for the HDR output that represents 100% white in the SDR input. The value range must be between 100 and 1000 nits. The default value is 203 nits. This parameter is only applied when the Grass Valley SDR to PQ BT.2100 LUT is selected.</p>

Property	Description
Auto table > SDR BT.709 narrow input	<p>When the Auto parameter is set under Global, a ✓ symbol shows that the card has detected this HDR type for the incoming video signal.</p> <p>Set the output HDR conversion for this input Video Payload ID (Transfer Characteristic, Colorimetry and Bit depth) type from the drop down list:</p> <ul style="list-style-type: none"> • Bypass • Force SDR BT.709 narrow • Force SDR BT.2020 narrow • Force HLG BT.2100 narrow • Force PQ BT.2100 narrow • Force PQ BT.2100 full • GV BT.709 to BT.2020 • GV SDR BT.709 to HLG BT.2100 • GV SDR BT.709 to PQ BT.2100 narrow • GV SDR BT.709 to PQ BT.2100 full • BBC SDR to HLG scene (4-1a - v1.5) • BBC SDR to HLG scene strict (4-2a - v1.5) • BBC SDR to HLG scene upmap (6-1a - v1.5) • BBC SDR to HLG scene upmap strict (6-2a - v1.5) • BBC SDR to HLG display (3c - v1.5) • BBC SDR to HLG display upmap (5c - v1.5) • BBC sRGB BT709 to HLG BT2020 (20c - v1.5) • NBCU SDR to HLG display upmap (SDR2HLG_DL_v1.1) • NBCU SDR to HLG scene tonemap (SDR2HLG_SL_v1) • NBCU SDR to PQ display upmap (SDR2PQ_DL_v1) • Custom LUT 1 to Custom LUT 8
Auto table > SDR BT.2020 narrow input	<p>When the Auto parameter is set under Global, a ✓ symbol shows that the card has detected this HDR type for the incoming video signal.</p> <p>Set the output HDR conversion for this input Video Payload ID (Transfer Characteristic, Colorimetry and Bit depth) type from the drop down list:</p> <ul style="list-style-type: none"> • Bypass • Force SDR BT.709 narrow • Force SDR BT.2020 narrow • Force HLG BT.2100 narrow • Force PQ BT.2100 narrow • Force PQ BT.2100 full • GV BT.2020 to BT.709 • BBC SDR BT2020 to HLG Display Directmap (17c - v1.5) • BBC SDR BT2020 to HLG Display Upmap (18c - v1.5) • Custom LUT 1 to Custom LUT 8

Property	Description
Auto table > HLG BT.2020 narrow input	<p>When the Auto parameter is set under Global, a ✓ symbol shows that the card has detected this HDR type for the incoming video signal.</p> <p>Set the output HDR conversion for this input Video Payload ID (Transfer Characteristic, Colorimetry and Bit depth) type from the drop down list:</p> <ul style="list-style-type: none"> • Bypass • Force SDR BT.709 narrow • Force SDR BT.2020 narrow • Force HLG BT.2100 narrow • Force PQ BT.2100 narrow • Force PQ BT.2100 full • GV HLG BT.2100 to SDR BT.709 • GV HLG BT.2100 to PQ BT.2100 narrow • BBC HLG to SDR scene (12-1c - v1.5) • BBC HLG to SDR scene strict (12-2c - v1.5) • BBC HLG to SDR display (8c - v1.5) • BBC HLG to SDR display harsh (9c - v1.5) • BBC HLG to PQ 1000 nits narrow range (7c - v1.5) • BBC HLG BT2020 to HLG BT2020 Display Hard Clip (19c - v1.5) • NBCU HLG to SDR display downmap (HLG2SDR_DL_v1.1) • NBCU HLG 1K to PQ transcode (HLG10002PQ_v1) • Custom LUT 1 to Custom LUT 8
Auto table > PQ BT.2020 narrow input	<p>When the Auto parameter is set under Global, a ✓ symbol shows that the card has detected this HDR type for the incoming video signal.</p> <p>Set the output HDR conversion for this input Video Payload ID (Transfer Characteristic, Colorimetry and Bit depth) type from the drop down list:</p> <ul style="list-style-type: none"> • Bypass • Force SDR BT.709 narrow • Force SDR BT.2020 narrow • Force HLG BT.2100 narrow • Force PQ BT.2100 narrow • Force PQ BT.2100 full • GV PQ BT.2100 narrow to SDR BT.709 • GV PQ BT.2100 narrow to HLG BT.2100 • BBC PQ 1000 nits narrow range to HLG (1e - v1.5) • BBC PQ 4000 nits narrow range to HLG (2e - v1.5) • NBCU PQ to SDR display downmap (PQ2SDR_DL_v1) • MovieLabs PQ 4K to HLG 1K Max RGB • Custom LUT 1 to Custom LUT 8
Auto table > PQ BT.2020 full input	<p>When the Auto parameter is set under Global, a ✓ symbol shows that the card has detected this HDR type for the incoming video signal.</p> <p>Set the output HDR conversion for this input Video Payload ID (Transfer Characteristic, Colorimetry and Bit depth) type from the drop down list:</p> <ul style="list-style-type: none"> • Bypass • Force SDR BT.709 narrow • Force SDR BT.2020 narrow • Force HLG BT.2100 narrow • Force PQ BT.2100 narrow • Force PQ BT.2100 full • GV PQ BT.2100 full to SDR BT.709 • BBC PQ 1000 nits full range to HLG (1c - v1.5) • BBC PQ 4000 nits full range to HLG (2c - v1.5) • Custom LUT 1 to Custom LUT 8

Property	Description
Auto table > Unknown	<p>When the Auto parameter is set under Global, a ✓ symbol shows that the card has not been able to detect any one of the five previous Video Payload ID (Transfer Characteristic, Colorimetry and Bit depth) types for the incoming video signal, set the output HDR mapping from the drop down list to use in this situation.</p> <ul style="list-style-type: none"> • Bypass • Force SDR BT.709 narrow • Force SDR BT.2020 narrow • Force HLG BT.2100 narrow • Force PQ BT.2100 narrow • Force PQ BT.2100 full • GV BT.709 to BT.2020 • GV BT.2020 to BT.709 • GV SDR BT.709 to HLG BT.2100 • GV HLG BT.2100 to SDR BT.709 • GV SDR BT.709 to PQ BT.2100 narrow • GV SDR BT.709 to PQ BT.2100 full • GV PQ BT.2100 narrow to SDR BT.709 • GV PQ BT.2100 full to SDR BT.709 • GV PQ BT.2100 narrow to HLG BT.2100 • GV HLG BT.2100 to PQ BT.2100 narrow • GV S-Log3/S-Gamut3 to BT.709 800% • GV S-Log3/S-Gamut3 to PQ BT.2100 narrow • GV S-Log3/S-Gamut3 to HLG BT.2100 • BBC SDR to HLG scene (4-1a - v1.5) • BBC SDR to HLG scene strict (4-2a - v1.5) • BBC SDR to HLG scene upmap (6-1a - v1.5) • BBC SDR to HLG scene upmap strict (6-2a - v1.5) • BBC SDR to HLG display (3c - v1.5) • BBC SDR to HLG display upmap (5c - v1.5) • BBC HLG to SDR scene (12-1c - v1.5) • BBC HLG to SDR scene strict (12-2c - v1.5) • BBC HLG to SDR display (8c - v1.5) • BBC HLG to SDR display harsh (9c - v1.5) • BBC PQ 1000 nits full range to HLG (1c - v1.5) • BBC PQ 4000 nits full range to HLG (2c - v1.5) • BBC PQ 4000 nits narrow range to HLG (2e - v1.5) • BBC HLG to PQ 1000 nits narrow range (7c - v1.5) • BBC S-Log3 100% scene to HLG (10a - v1.5) • BBC S-Log3 200% scene to HLG (11a - v1.5) • BBC SDR BT2020 to HLG Display Directmap (17c - v1.5) • BBC SDR BT2020 to HLG Display Upmap (18c - v1.5) • BBC HLG BT2020 to HLG BT2020 Display Hard Clip (19c - v1.5) • BBC sRGB BT709 to HLG BT2020 (20c - v1.5) • NBCU SDR to HLG display upmap (SDR2HLG_DL_v1.1) • NBCU SDR to HLG scene tonemap (SDR2HLG_SL_v1) • NBCU HLG to SDR display downmap (HLG2SDR_DL_v1.1) • NBCU SDR to PQ display upmap (SDR2PQ_DL_v1) • NBCU PQ to SDR display downmap (PQ2SDR_DL_v1) • MovieLabs PQ 4K to HLG 1K Max RGB • NBCU HLG 1K to PQ transcode (HLG10002PQ_v1) • Custom LUT 1 to Custom LUT 8

Property	Description
Applied Conversions table > Transfer Characteristic	Shows the applied conversion according to the above settings. The currently-forced HDR conversion, or the bypass HDR type is displayed in parenthesis.
Colorimetry	
Range	

NBCU LUTs, credit NBCU and Chromorama.

Custom LUTs Tab

This tab allows you to load up to 8 custom LUTs (**LUT1** to **LUT8**) that can be selected for use in the **UDCn** tabs. The XIP only supports files that conform to the Adobe Cube file v1.0 format. Custom LUTs are shared among all XIP applications. This feature requires the **XIP-3901-UDC-HDR** option. See [Options Panel](#), on page 176 for details about how to activate card options.

You can Load up to 8 LUTs. For each custom LUT you load, you need to specify input/output colorimetry, input/output range and output transfer characteristics.



Fig. 9-19: Custom LUTs Tab

Property	Custom LUTs Parameters	Available Values	Description
Input	Colorimetry	BT.709, BT.2020	The Input Colorimetry and Input Range are used for the input YCbCr to RGB color space conversion.
	Input Range	Narrow, Full	
Output	Colorimetry	BT.709, BT.2020	The Output Colorimetry and Output Range are used for the output RGB to YCbCr color space conversion.
	Output Range	Narrow, Full	
	Transfer Characteristic	SDR, HLG, PQ, Unspecified	The Transfer Characteristic does not participate in the HDR and color space conversions. Along with the Output Colorimetry and Output Range, it is only used to indicate the HDR type at the output of the HDR processor.

Property	Custom LUTs Parameters	Available Values	Description
Files	–	Click  to upload or replace a LUT file. Click X to remove the currently loaded LUT file.	The name of the currently loaded LUT file will be partially displayed. Mouse-over the field to display the full name. The background will change to RED if the uploaded file is invalid.

Metadata Panel

The **Metadata** panel has four tabs (**UDC1** to **UDC4**); one for each of XIP-3901-UDC-IF's independent processing channels. The configuration of all **UDCn** tabs are the same as the **UDC1** tab. Only the configuration of the **UDC1** tab is shown below.

When the **Dual UHD/HD** option for the **Operating Mode** has been selected, the **UDC3** and **UDC4** tabs become unavailable. See [Setting the Card's Operating Mode](#), on page 180 for more information.

The XIP-3901-UDC-IF manages the transfer of metadata between its input and output, but does not process the metadata information regarding the video conversion. In the Metadata Panel, you can selectively pass or block any one of eight specific ANC data types by specifying the DIDs and SDIDs to be passed from input to output and those that are to be blocked.

In the case of **Time Code** option, when set to the **Process** mode, utilizes the controls under the **Timecode** tab. When the card's **Operating Mode** in the **Factory Presets** panel is set to the **SDI Only** option, the PTP timecode is unavailable to the card as no network is available. In this scenario, ensure to set the **Timecode Processing** to **SDI**. See [Setting the Card's Operating Mode](#), on page 180 for more information.



Fig. 9-20: Metadata panel UDCn Tabs

Property	Description
Metadata DID (HEX) SDID (HEX)	<p>Use any of the eight pulldowns to select the metadata you want to pass or block. You can select any predefined Metadata and the card will manage DID and SDID for you:</p> <ul style="list-style-type: none"> • Time Code: DID/SDID = 60h/60h. When set to Process mode, this activates the controls under the Timecode tab at the bottom of the panel. • Closed Captioning EIA-708-B: DID/SDID = 61h/01h • Closed Captioning EIA-608-B: DID/SDID = 61h/02h • Teletext OP-47: DID/SDID = 43h/02h • AFD: DID/SDID = 41h/05h • SCTE 104: DID/SDID = 41h/07h • Audio Metadata 01: DID/SDID = 45h/01h • Audio Metadata 02: DID/SDID = 45h/02h • Audio Metadata 03: DID/SDID = 45h/03h • Audio Metadata 04: DID/SDID = 45h/04h • Audio Metadata 05: DID/SDID = 45h/05h • Audio Metadata 06: DID/SDID = 45h/06h • Audio Metadata 07: DID/SDID = 45h/07h • Audio Metadata 08: DID/SDID = 45h/08h • Audio Metadata 09: DID/SDID = 45h/09h • Custom: you can specify a custom metadata by specifying DID and SDID. <p>You cannot set the same metadata twice based on DID and SDID.</p>
Presence	<p>Shows if the selected metadata type has been detected. The status indicator shows the current metadata status:</p> <p>Green: the selected metadata is present. Grey: the selected metadata is not present.</p>
Insertion	<p>Set whether the detected ancillary packet is to be inserted into the card's output:</p> <p>Pass: allow the detected ancillary packet is to be passed through the card. Block: drop the detected ancillary packet from being passed through the card. Process: When Timecode is set to Process mode, this utilizes the controls under the Timecode tab at the bottom of the panel. In this mode, the input ATC-VITC is discarded.</p>
Apply Cancel	<p>When active, this applies or rejects your current changes made in this tab.</p>

Property	Description
Timecode HD/UHD Source	<p>Select the source containing Timecode information for further processing.</p> <p>SDI: Extract Timecode from the SDI metadata stream in the format of ATC LTC timecode. The presence status of ATC LTC timecode is reflected through the color of the associated LED:</p> <ul style="list-style-type: none"> • Green: ATC LTC timecode packet present • Red: ATC LTC timecode packet not present <p>NOTE: When the card's Operating Mode in the Factory Presets panel is set to the SDI Only option, ensure during Process Insertion the Timecode is set to be extracted from the SDI input.</p> <p>PTP: Extract Timecode from the PTP packet and extract the following additional information from the TLV messages:</p> <ol style="list-style-type: none"> 1 System Frame Rate associated with the timecode information. 2 Local Offset and the derive Local Time form Local Offset. 3 Style of Timecode DF (drop frame) or NDF (non-drop frame). <p>The presence status of all three TLV's is reflected through the color of the associated LED:</p> <ul style="list-style-type: none"> • Green: SM TLV timecode packet present • Red: SM TLV timecode packet not present
Local time offset	<p>For the PTP option, when there is no TLV Status (status LED is red), set your UTC time zone offset for your geographic location with the dropdown list.</p>
Drop Frame	<p>For the PTP option, when there is no TLV Status (status LED is red), set the timecode type with the dropdown list:</p> <p>DF: Drop frame.</p> <p>NDF: Non-drop frame.</p>
Output Timecode	<p>Shows the output timecode in Hours:Min:Sec and the timecode type: DF (drop frame) or NDF (non-drop frame). Only active when Time Code under Metadata is set to Process.</p>

Audio Panel

The **Audio** panel has four tabs (**UDC1** to **UDC4**); one for each of XIP-3901-UDC-IF's independent processing channels. The configuration of all **UDCn** tabs are the same as the **UDC1** tab. Only the configuration of the **UDC1** tab is shown below.

When the **Dual UHD/HD** option for the **Operating Mode** has been selected, the **UDC3** and **UDC4** tabs become unavailable. See [Setting the Card's Operating Mode](#), on page 180 for more information.

For **Audio 2** to **Audio 4**, only the first 16 channels will carry active audio and channels 17-64 will carry silence.

The relative processing order of audio panel components is shown below.

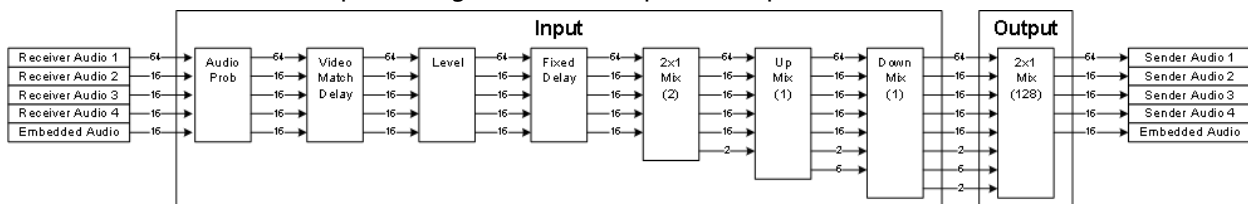

Fig. 9-21: Overview of XIP-3901-UDC-IF Audio Processing

Certain of the above audio processing components are only available when the **XIP-3901-UDC-AUD** option is enabled. See [Optional XIP-3901-UDC-IF v4.0 Application Audio processing, Down/Up Mix, Shuffling](#), on page 31 for the feature overview for this licensed option. Without the **XIP-3901-UDC-AUD** option, the following tabs are unavailable: **Mixer**, **Upmix**, and **Downmix**.

SMPTE ST 2110-30/-31 IP audio inputs (**Receiver Audio 1 / 2 / 3 / 4**) are only available when the card's **Operating Mode** in the **Factory Presets** panel is set to the **SDI and IP Hybrid** option. See [Setting the Card's Operating Mode](#), on page 180 for more information.

Inputs Tab

This tab allows you to set individual audio stream input parameters such as the level, delay, phase invert, and to mute an input. This tab also supports audio probing: embedded audio group detection, audio presence and audio type for all incoming audio channels. There are also tabs for incoming audio: **Embedded Audio**, **Audio 1**, **Audio 2**, **Audio 3**, and **Audio 4**.

Tab	Audio Channels Supported	Description
Embedded Audio	CH1 to CH16	Embedded SDI audio channels. See Config Tab , on page 189.

Configuring the XIP 3901-UDC-IF v4.0 Application with iControl
Inputs Tab

Tab	Audio Channels Supported	Description
Audio 1	CH1 to CH64	SMPTE ST 2110-30/31 IP Audio. See Config Tab , on page 201. These input streams are available when: <ul style="list-style-type: none"> • The card's Operating Mode in the Factory Presets panel is set to the SDI and IP Hybrid option. See Setting the Card's Operating Mode, on page 180 for more information. • And the XIP-3901-UDC-AUD option is installed. To install the XIP-3901-UDC-AUD option, see Options Panel, on page 176.
Audio 2	CH1 to CH16	
Audio 3	CH1 to CH16	
Audio 4	CH1 to CH16	

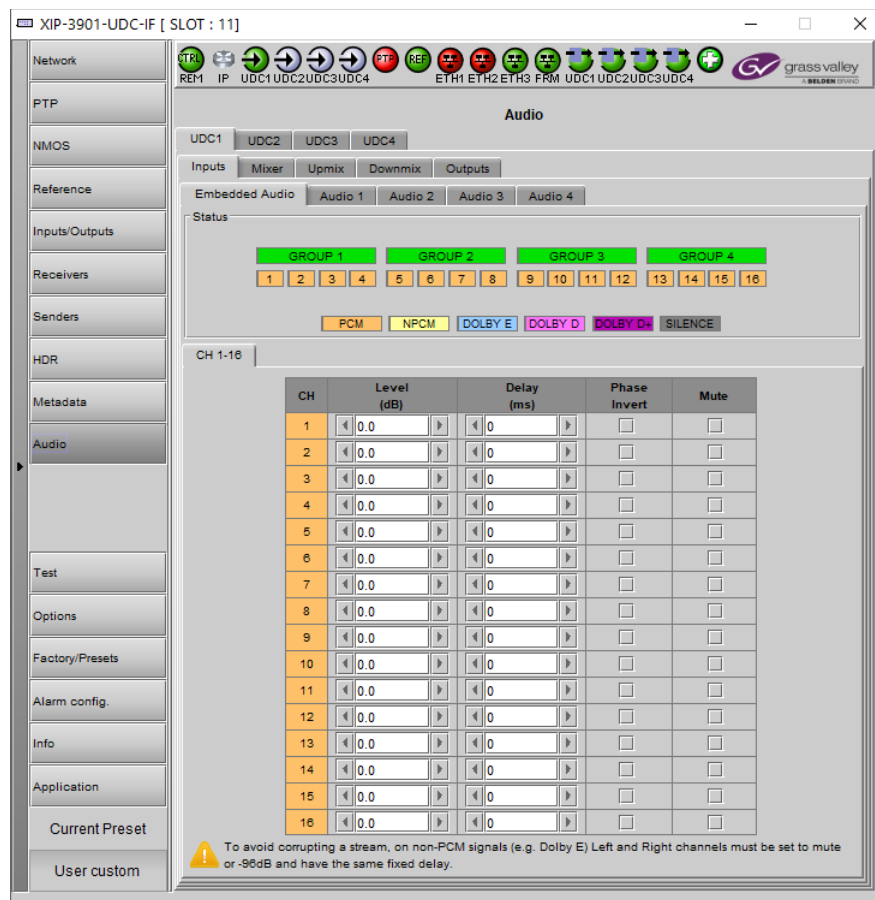

Fig. 9-22: Audio Inputs Tab

Property	Description
Status	<p>Shows audio group 1 to 4 detection for embedded audio:</p> <p>Green: Audio Group present</p> <p>Grey: Audio Group not present</p> <p>PCM Signal is present and detected audio type is PCM</p> <p>NPCM Signal is present and detected audio type is NPCM</p> <p>Dolby E Signal is present and detected audio type is Dolby E</p> <p>Dolby D Signal is present and detected audio type is Dolby Digital (Dolby D)</p> <p>Dolby D+ Signal is present and detected audio type is Dolby Digital plus (Dolby D+)</p> <p>Silence Signal not present because a silence of -60 dBFS or less was detected for over 3 seconds</p>
Level	<p>Sets input gain level for an audio channel. At -96dB, the signal is completely muted. You can mouse over the level setting to see the available range. The range is always -96 to 12dB and can be set in 0.5 dB steps. By default no gain level is applied (0 dB). This setting has no effect on a non-PCM audio channel except if this level is set to -96dB (signal is muted).</p> <p>This feature requires the XIP-3901-UDC-AUD option. See Options Panel, on page 176 for details about how to activate card options.</p>
Delay	<p>You can delay or advance audio from the nominal value, in order to deal with problems such as lip-sync errors and audio phase alignment in the incoming feed.</p> <p>You can delay of up to 500 ms in steps of 1 ms. To advance audio, you need first to delay the video. Video can be delayed up to 6 fields/frames. As an example, if you delay 1920x1080p59Hz output by 2 frames, you can advance the audio by up to 66ms.</p> <p>At any time you can mouse over this field to see the current available fixed delay range. By default no fixed delay is applied (0ms).</p> <p>A fixed delay can still be used with non-PCM signals, but you must use the same delay values for the left and right channels to preserve signals such as Dolby E.</p> <p>This feature requires the XIP-3901-UDC-AUD option. See Options Panel, on page 176 for details about how to activate card options.</p>
Phase Invert	<p>Set to phase invert an audio channel. This setting has no effect on a non-PCM audio channel. By default, phase invert is disabled.</p> <p>This feature requires the XIP-3901-UDC-AUD option. See Options Panel, on page 176 for details about how to activate card options.</p>
Mute	<p>Set to mute an audio channel. By default, mute is disabled.</p>

Mixer Tab

This tab provides two 2×1 mixers. Each mixer adds two new audio mix output channels that are added to the audio processing path: **Mixer - CH1** and **Mixer - CH2**. These channels are available as inputs to other audio processing tabs. See also [Overview of XIP-3901-UDC-IF Audio Processing](#), on page 225.

All incoming audio channels are available for mixing:

Audio Channel	Description	Note
Audio 1 - CH1 to CH64	Audio coming from the 1st audio receiver.	These input streams are available when: <ul style="list-style-type: none"> The card's Operating Mode in the Factory Presets panel is set to the SDI and IP Hybrid option. See Setting the Card's Operating Mode, on page 180 for more information. And the XIP-3901-UDC-AUD option is installed. To install the XIP-3901-UDC-AUD option, see Options Panel, on page 176.
Audio 2 - CH1 to CH16	Audio coming from the 2nd audio receiver.	
Audio 3 - CH1 to CH16	Audio coming from the 3rd audio receiver.	
Audio 4 - CH1 to CH16	Audio coming from the 4th audio receiver.	
Embed - CH1 to Embed - CH16	Audio coming from the selected SDI input.	-

This tab is available when the **XIP-3901-UDC-AUD** option is installed. See [Options Panel](#), on page 176 for details about how to activate card options.

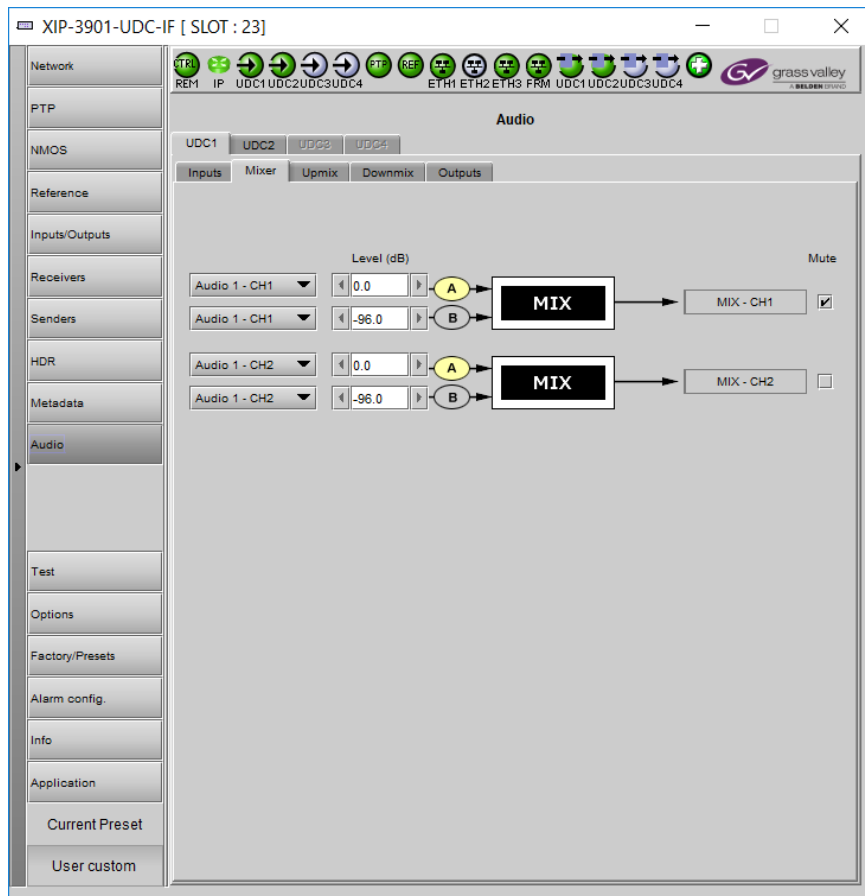

Fig. 9-23: Audio Mixer Tab

Property	Description
Inputs: Mixer Source A and Source B	Select audio sources.
Level	Sets input gain level for an audio channel. At -96dB, the signal is completely muted. You can mouse over the level setting to see the available range. The range is always -96 to 12dB and can be set in 0.5 dB steps. By default no gain level is applied (0 dB). By default, Source A is passed-through and Source B is muted. If one audio mix input channel is non-PCM, Source A will pass-through except if its level setting is -96dB (signal is muted).
Mute	Set to mute a mixed audio channel output. By default, mixed signals are not muted.

Upmix Tab

This tab allows you to upmix stereo audio channels into simulated 5.1 surround sound. Upmix generates 6 new audio channels that are added to the audio processing path: **UPMIX - CH1 to CH6** that can be used as inputs to other audio processing tabs. See also [Overview of XIP-3901-UDC-IF Audio Processing](#), on page 225.

All incoming audio channels and new mixed audio channels are available:

Audio Channel	Description	Note
Audio 1 - CH1 to CH64	Audio coming from the 1st audio receiver.	These input streams are available when: <ul style="list-style-type: none"> The card's Operating Mode in the Factory Presets panel is set to the SDI and IP Hybrid option. See Setting the Card's Operating Mode, on page 180 for more information. And the XIP-3901-UDC-AUD option is installed. To install the XIP-3901-UDC-AUD option, see Options Panel, on page 176.
Audio 2 - CH1 to CH16	Audio coming from the 2nd audio receiver.	
Audio 3 - CH1 to CH16	Audio coming from the 3rd audio receiver.	
Audio 4 - CH1 to CH16	Audio coming from the 4th audio receiver.	
Embed - CH1 to Embed - CH16	Audio coming from the selected SDI input.	-
Mixer - CH1 to CH2	Mixed audio channels.	-

This tab is available when the **XIP-3901-UDC-AUD** option is installed. See [Options Panel](#), on page 176 for details about how to activate card options.



Fig. 9-24: Audio Upmix Tab

Property	Description
Inputs: Left (L), Right (R) Inputs	Select audio sources. If one or more upmix input channel is non-PCM, all UPMIX output channels will be muted.
Operation	OFF: Disable upmix processing. UPMIX – CH1 to UPMIX – CH6 outputs are muted. ON: Enable upmix processing. By default, upmix is disabled.
Stereo Mix Level	Set the gain level for the left and right upmix channels. Possible values are: +3.0 dB, +1.5 dB, 0.0 dB, -1.5 dB, -3.0 dB, -4.5 dB, -6.0 dB and Mute. The default level is -3.0 dB.
Center Mix Level	Set the gain level for the center upmix channel. Possible values are: +3.0 dB, +1.5 dB, 0.0 dB, -1.5 dB, -3.0 dB, -4.5 dB, -6.0 dB, and Mute. The default level is -3.0 dB.
Surround Mix Level	Set the gain level for the left surround and right surround upmix channels. Possible values are: +3.0 dB, +1.5 dB, 0.0 dB, -1.5 dB, -3.0 dB, -4.5 dB, -6.0 dB, and Mute. The default level is -3.0 dB.

Property	Description
LFE Mix Level	Set the gain level for the low-frequency effects (LFE) upmix channel. Possible values are: +10.0 dB, + 9.0 dB, +7.5 dB, +6.0 dB, +4.5 dB, +3.0 dB, +1.5 dB, 0.0 dB, -1.5 dB, -3.0 dB, -4.5 dB, -6.0 dB, and Mute. The default level is Muted.
LFE Filter Frequency	Set the crossover frequency for bass at which: <ul style="list-style-type: none"> • Bass program content is filtered to the low-frequency effects (LFE) upmix channel. • The remaining upper frequency band is filtered to the other upmix channels (left, right, center, left surround, and right surround). • The default frequency is 120Hz.

Downmix Tab

This tab allows the downmix of a 5.1 surround sound signal to a LoRo or LtRt stereo channel pair or of a 5.1.4 surround sound signal to 5.1 and LoRo stereo channel pair at the same time.

- With a 5.1 source the Downmix generates 2 new audio channels that are added to the audio processing path: DMIX - CH1 to CH2 that can be used as inputs to other audio processing tabs.
- With a 5.1.4 source the Downmix generates 8 new audio channels that are added to the audio processing path: DMIX - CH1 to CH8 that can be used as inputs to other audio processing tabs.

See also [Overview of XIP-3901-UDC-IF Audio Processing](#), on page 225.

All incoming audio channels, new mixed and upmixed audio channels are available:

Audio Channel	Description	Note
Audio 1 - CH1 to CH64	Audio coming from the 1st audio receiver.	These input streams are available when: <ul style="list-style-type: none"> • The card's Operating Mode in the Factory Presets panel is set to the SDI and IP Hybrid option. See Setting the Card's Operating Mode, on page 180 for more information. • And the XIP-3901-UDC-AUD option is installed. To install the XIP-3901-UDC-AUD option, see Options Panel, on page 176.
Audio 2 - CH1 to CH16	Audio coming from the 2nd audio receiver.	
Audio 3 - CH1 to CH16	Audio coming from the 3rd audio receiver.	
Audio 4 - CH1 to CH16	Audio coming from the 4th audio receiver.	
Embed - CH1 to Embed - CH16	Audio coming from the selected SDI input.	–
Mixer - CH1 to CH2	Mixed audio channels.	–
Upmix - CH1 to CH6	Upmixed audio channels.	–

This tab is available when the XIP-3901-UDC-AUD option is installed. See [Options Panel](#), on page 176 for details about how to activate card options.

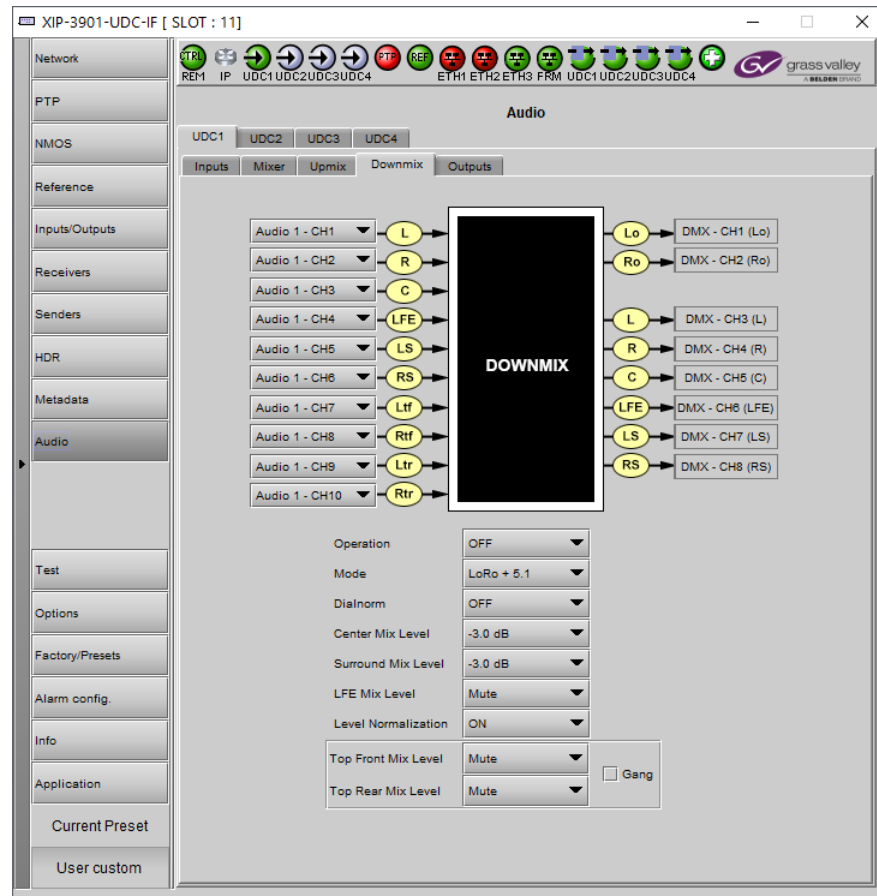
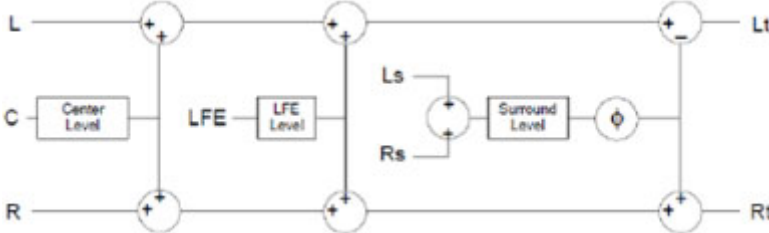
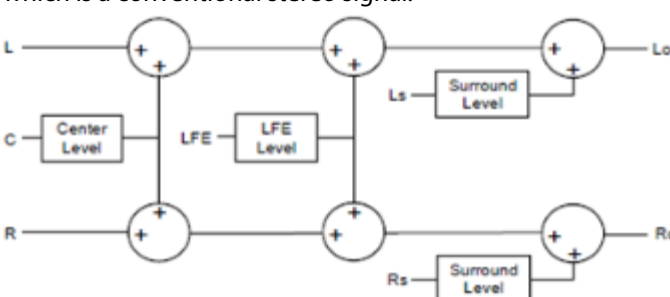
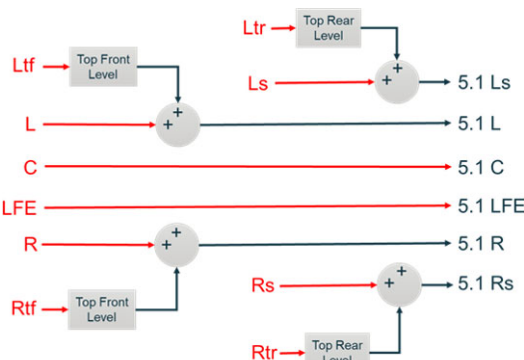
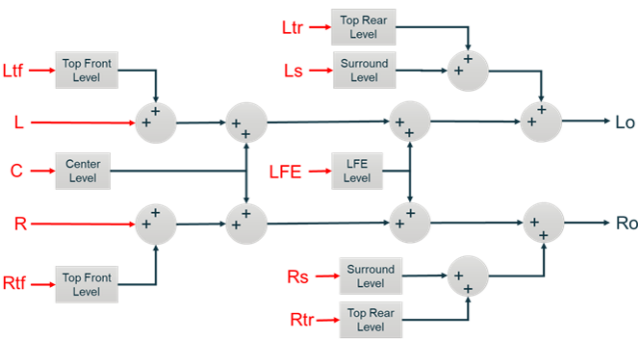

Fig. 9-25: Audio Downmix Tab

Property	Description
Inputs: Left (L), Right (R), Center (C), LFE, Left surround (LS), Right surround (LR), Left top front (Ltf), Right top front (Rtf), Left top rear (Ltr), and Right top rear (Rtr)	Select audio sources. If one or more downmix input channel is non-PCM (such as Dolby), all DMIX output channels will be muted. NOTE: Ltf, Ltr, Rtf, Rtr inputs channel assignment to the Downmix processor is only relevant if the processor's mode is set to LoRo + 5.1; any channel assignment with the LoRo or LtRt mode active will be ignored by the Downmix processor.
Operation	OFF: Disable downmix processing. All DMIX outputs channels are muted. ON: Enable downmix processing.

Property	Description
Mode	<p>LtRt: Enables the downmix of 5.1 channels into an LtRt (Left total Right total) matrix surround encoded stereo pair.</p>  <p>LoRo: Enables the downmix of 5.1 channels into a LoRo (Left only Right only) stereo pair, which is a conventional stereo signal.</p>  <p>LoRo + 5.1: Enables the downmix of 5.1.4 channels into a 5.1 channels and a stereo pair.</p> <ul style="list-style-type: none"> Downmix of 5.1.4 channels into a 5.1 channels.  <ul style="list-style-type: none"> Downmix of 5.1.4 channels into a LoRo (Left only Right only) stereo pair, which is a conventional stereo signal. 

Property	Description
Dialmorm	Set the dialog normalization level. Possible values are: -31 dBFS to -1 dBFS, and OFF. Default value is OFF.
Center Mix Level	Set the gain level for the center downmix channel. Possible values are: +3.0 dB, +1.5 dB, 0.0 dB, -1.5 dB, -3.0 dB, -4.5 dB, -6.0 dB, and Mute The default level is -3.0 dB.
Surround Mix Level	Set the gain level for the left surround and right surround downmix channels. Possible values are: +3.0 dB, +1.5 dB, 0.0 dB, -1.5 dB, -3.0 dB, -4.5 dB, -6.0 dB, and Mute. The default level is -3.0 dB.
LFE Mix Level	Set the gain level for the low-frequency effects (LFE) downmix channel. Possible values are: +10.0 dB, +9.0 dB, +7.5 dB, +6.0 dB, +4.5 dB, +3.0 dB, +1.5 dB, 0.0 dB, -1.5 dB, -3.0 dB, -4.5 dB, -6.0 dB, and Mute. The default level is mute.
Level Normalization	OFF: Disable output level normalization. ON: Enable output level normalization: the output level is normalized based on the applied mix levels to provide a uniform output over the range of mix levels available. Clipping will never occur, even with full scale input channels and mix levels. Default value is ON.
Top Front Mix Level	When Mode is set to LoRo + 5.1 , set the gain level for the Top Front downmix channel. Possible values are: +6dB to -25dB in steps of 0.5dB, and Mute. The default level is mute.
Top Rear Mix Level	When Mode is set to LoRo + 5.1 , set the gain level for the Top Rear downmix channel. Possible values are: +6dB to -25dB in steps of 0.5dB, and Mute. The default level is mute.
Gang	Set to group the settings of Top Front Mix Level and Top Front Mix Level together.

Outputs Tab

This tab allows you to shuffle and mix audio output streams down to a maximum of 128 output channels. There is a tab for each audio output: **Audio 1**, **Audio 2**, **Audio 3**, and **Audio 4**.

All incoming audio channels and all new generated audio channels are available:

Audio Channel	Description	Note
Audio 1 - CH1 to CH64	Audio coming from the 1st audio receiver.	These input streams are available when the card's Operating Mode in the Factory Presets panel is set to the SDI and IP Hybrid option. See Setting the Card's Operating Mode , on page 180 for more information.
Audio 2 - CH1 to CH16	Audio coming from the 2nd audio receiver.	
Audio 3 - CH1 to CH16	Audio coming from the 3rd audio receiver.	
Audio 4 - CH1 to CH16	Audio coming from the 4th audio receiver.	
Embed - CH1 to Embed - CH16	Audio coming from the selected SDI input.	-

Audio Channel	Description	Note
Mixer - CH1 to CH2	Mixed audio channels.	–
Upmix - CH1 to CH6	Upmixed audio channels.	–
Dmix - CH1 to CH8	Downmixed audio channels.	–

The output processing (shuffler and mixer) will set the following outgoing audio channels:

Output Audio Channel	Description	Note
Embed - CH1 to Embed - CH16	SDI output embedded audio.	–
Audio 1 CH1 to CH64	1st audio sender.	These input streams are available when the card's Operating Mode in the Factory Presets panel is set to the SDI and IP Hybrid option. See Setting the Card's Operating Mode , on page 180 for more information.
Audio 2 CH1 to CH16	2nd audio sender.	
Audio 3 CH1 to CH16	3rd audio sender.	
Audio 4 CH1 to CH16	4th audio sender.	



Fig. 9-26: Audio Outputs Tab

Configuring the XIP 3901-UDC-IF v4.0 Application with iControl
Outputs Tab

Property	Description
Inputs: Mixer Source A and Source B	Select audio sources.
Level	Sets input gain level for an audio channel. At -96dB, the signal is completely muted. You can mouse over the level setting to see the available range. The range is always -96 to 12dB and can be set in 0.5 dB steps. By default no gain level is applied (0 dB). By default, Source A is passed-through and Source B is muted. If one audio mix input channel is non-PCM, Source A will pass-through except if its level setting is -96dB (signal is muted).
Mute	Set to mute a mixed audio channel output. By default, mixed signals are not muted.

Test Panel

You may activate the Color Bars & Tone test signal for the two channels independently by enabling the appropriate checkboxes.

When the **Dual UHD/HD** option for the **Operating Mode** has been selected, the **UDC3** and **UDC4** test signal options become unavailable. See [Setting the Card's Operating Mode](#), on page 180 for more information.

The XIP-3901-UDC-IF's **Test Panel** configuration is the same as the XIP-3901-UDC-IP's **Test Panel** configuration; see [Test Panel](#), on page 174.

10

Configuring the XIP-3901-GB-IP Application with iControl

XIP-3901-UC, XIP-3901-DC, or XIP-3901-FS	XIP-3901-UDC-IP	XIP-3901-UDC-IF	XIP-3901-GB-IP	XIP-3901-JPEG XS	XIP-3901-ASI
			●		

This section describes the control panels associated with the XIP-3901-GB-IP application and its use.

Network Panel

The Network panel is used to set the network configuration of the media and control Ethernet ports on the XIP-3901-GB-IP.

The XIP-3901-GB-IP's **Network** Panel configuration is the same as the XIP-3901-UDC-IP's **Network** Panel configuration, including all tabs; see [Network Panel](#), on page 125.

PTP Panel

To allow vertically accurate video frame synchronization, multicast Precision Timing Protocol (described in IEEE Standard 1588) is used to distribute time across a packet network. It is used on both media ports (ETH1 and ETH2) for BMCA redundancy. This supports Best Master Clock Algorithm (BMCA) as per IEEE-1588-2008.

The XIP-3901-GB-IP's **PTP** Panel configuration is the same as the XIP-3901-UDC-IP's **PTP** Panel configuration; see [PTP Panel](#), on page 131.

NMOS Panel

XIP-3901-GB-IP supports Networked Media Open Specifications (NMOS) AMWA IS-04 for device discovery and registration and IS-05 for connection management. Furthermore, it supports AMWA BCP-002 recommendations for Grouping NMOS Resources.

The XIP-3901-GB-IP's **NMOS** Panel configuration is the same as the XIP-3901-UDC-IP's **NMOS** Panel configuration; see [NMOS Panel](#), on page 133.

Receivers Panel

The Receivers panel has two tabs (**GB1** and **GB2**); one for each of XIP-3901-GB-IP's independent processing channels. The configuration of the **GB2** tab is the same as the **GB1** tab. Only the configuration of the **GB1** tab is shown below.

Each channel can:

- Receive up to four SMPTE 2110-20 video streams:
 - 4 × 3G 2SI division 1080p IP input signals
 - 4 × 3G square division 1080p IP input signals
 - 1 × 12G single-stream 2160p IP input signal
- Receive full ancillary space on one SMPTE 2110-40 metadata stream
- Receive 4 audio streams
 - Audio 1 can receive up to 64 audio channels
 - Audio 2 to 4 can receive up to 64 audio channels, but only audio channel 1 to 16 are passed through. Audio channels 17 to 64 will contain silence.

Statuses confirm that the RTP stream is being correctly received.

Config Tab

This tab allows you to configure the expected source media's:

- Video link operating mode associated to this input stream: single-stream 12G or quad-stream 3G.
- Audio channels, stream address, port, and IGMPv3 source.
- The receivers are SMPTE ST 2110-20 (Video), ST 2110-40 (Meta 1), and ST 2110-30 (Audio 1, Audio 2, Audio 3, And Audio 4).

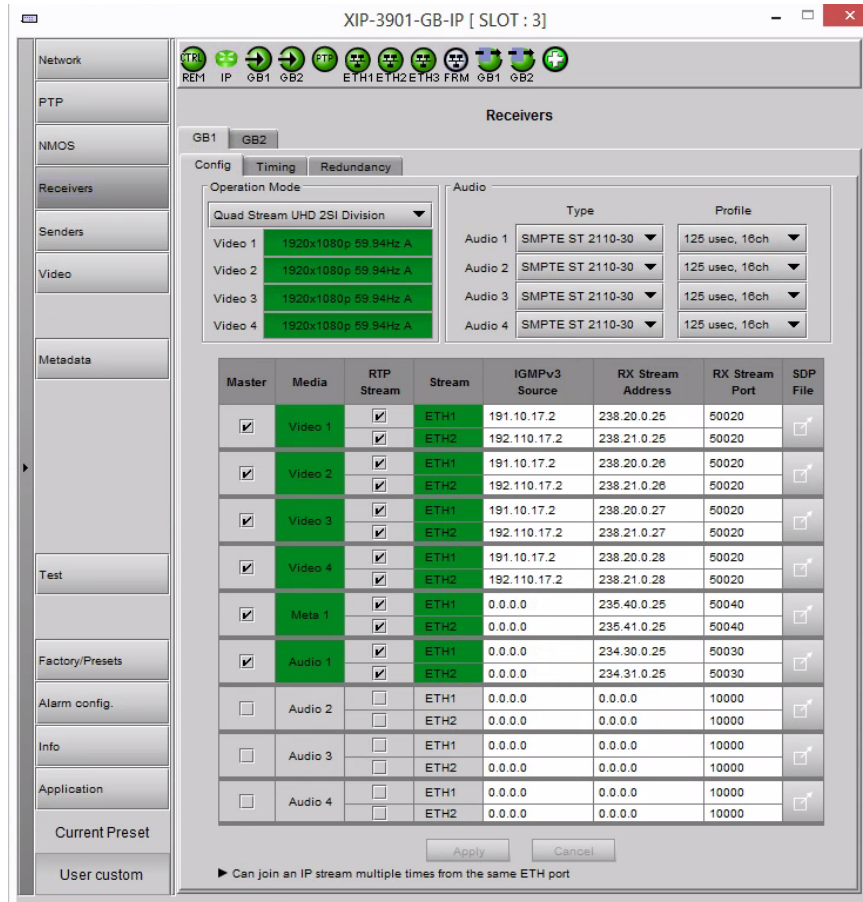

Figure 10-1: Receivers Config Tab

Property	Description
Operation Mode	<p>Quad Stream UHD 2SI Division: Provide the card with 4 × 3G 2SI division 1080p IP input signals.</p> <p>Quad Stream UHD Square Division: Provide the card with 4 × 3G square division 1080p IP input signals.</p> <p>Single Stream UHD: Provide the card with 1 × 12G single-stream 2160p IP input signal.</p>
Video 1 to Video 4	<p>Shows the video source stream's current status: resolution / frame rate or signal absence (No Carrier). The color shows the source stream's current status:</p> <p>Green: streaming</p> <p>Red: not streaming</p> <p>Grey: not active</p> <p>When the Operation Mode is Quad Stream UHD 2SI Division or Quad Stream UHD Square Division, Video 1 to Video 4 should be green.</p> <p>When the Operation Mode is Single Stream UHD, Video 1 should be green and Video 2 to Video 4 should be grey.</p>

Property	Description
Audio	<p>Type: Use the pull-down to set the audio source stream's type for streams Audio 1 to Audio 4.</p> <ul style="list-style-type: none"> • Type SMPTE ST 2110-30: for PCM linear audio (AES67 compatible) • Type SMPTE ST 2110-31: for transparent transport of non-linear audio and data formats: provides bit-transparent AES3 over IP <p>Profile: Use the pull-down to set the audio profile for streams Audio 1 to Audio 4. Audio receivers support Level C as per SMPTE 2110-30/31: 48kHz stream from 1 to 8 channels (1 to 4 for SMPTE 2110-31) at packet times of 1ms and 1 to 64 channels (1 to 60 for SMPTE 2110-31) at packet time of 125us.</p> <p>These settings can also be managed by external NMOS control. See NMOS Panel, on page 239.</p>
Master	<p>Set to enable a media receiver. This manages the Join/Release of both the primary and secondary streams.</p> <p>These settings can also be managed by external NMOS control. See NMOS Panel, on page 239.</p>
Media	<p>Shows the stream type. The background shows the current media status:</p> <p>Green: no error Red: error Grey: inactive</p> <p>When the Operation Mode is Quad Stream UHD 2SI Division or Quad Stream UHD Square Division, Video 1 to Video 4 should be green.</p> <p>When the Operation Mode is Single Stream UHD, Video 1 should be green and Video 2 to Video 4 should be grey.</p>
RTP Stream	Set to enable each stream receiver individually (primary and secondary).
Stream	<p>Shows the primary (ETH1) and secondary (ETH2) stream receiver status:</p> <p>Green: no error Red: error Grey: inactive</p>
IGMPv3 Source	<p>Set the source from which to receive multicast streams. With this protocol, the card deals with a switch to subscribe to one or many streams that are coming from different sources. Both iGMPv3 and iGMPv2 protocols are supported. Set this to 0.0.0.0 if iGMP source is not used. The source range is 0.0.0.0 to 255.255.255.255. The default value is 0.0.0.0.</p> <p>These settings can also be managed by external NMOS control. See NMOS Panel, on page 239.</p>
RX Stream Address	Set the IP address and UDP port number at which this card receives a specific stream. IP address 0.0.0.0 disables a receiver. The default UDP port values are: 10000 for all media receivers.
RX Stream Port	These settings can also be managed by external NMOS control. See NMOS Panel , on page 239.

Property	Description
SDP File	Click to show the last SDP file received through NMOS IS-05 since the last bootup. This window does not refresh automatically; you need to close and re-open the window to see an update. If the card has never received an SDP file since last its last bootup, the window will be empty.
Apply Cancel	When active, this applies or rejects your current changes made in this tab except for Operation Mode, Audio Type, and Audio Profile.

Timing Tab

This tab allows you to view the network health of the stream’s connection (link latency, receiver buffer level, and offset time).



Figure 10-2: Receivers Timing Tab

Property	Description
Media	Shows the stream type. The background shows the current media status: Green: No error Red: Error Grey: Inactive
Stream	Shows the primary (ETH1) and secondary (ETH2) stream receiver status: Green: No error Red: Error Grey: Inactive
Link Latency	Shows the time it takes for a packet to come from the source to the receiver. This measurement represents the difference between incoming RTP timestamp and PTP time before the receiver's buffer.
Buffer level	Shows the amount of preloaded data stored in the receiver that is ready for use in microseconds and in percentage. The current buffer level in microseconds shows the minimum latency required to receive a continuous stream. The current buffer level in percentage shows how much of the internal buffering is used to receive the current stream.
Link Offset	Shows the resulting link latency after being read out from receiver's buffer. This measurement is the difference between the packet RTP timestamp and the PTP time after the receiver's buffer and represents the total reception delay.
Syntonized Audio 1 to 4	Set to ignore Audio RTP timestamps. Audio buffer reception is then fixed to 25%. Use these settings to manage audio streams that are not properly time stamped. Enable syntonize for audio 1 to 4 individually.

Redundancy Tab

This tab allows you to view the reception state regarding SMPTE ST 2022-7 redundancy. The primary and secondary streams, at the packet level, will work together in order to produce a valid resulting stream. To achieve redundancy, both streams need to be in range with respect to the receiver buffer. In the circumstance in which only one stream is successfully received, the resulting stream will be valid as well but without any active redundancy protection.

The XIP-3901-GB-IP's **Receivers Panel, Redundancy** tab configuration is the same as the XIP-3901-UDC-IP's **Receivers Panel, Redundancy** tab configuration; see [Redundancy Tab](#), on page 138.

Senders Panel

The Senders panel has three tabs (**GB1**, **GB2**, and **Advanced**); **GB1** and **GB2** are for each of XIP-3901-GB-IP's independent processing UHD channels. The **Advanced** tab allows you to configure the outgoing payload type and DSCP priority.

GB1 / GB2 Tabs

These tabs allow you to configure the destination media’s video format, audio channels, and the SMPTE ST 2110 output stream’s IP addresses and port numbers.

Each channel can:

- Send up to four SMPTE 2110-20 video streams (**Video 1 to Video 4**):
 - 4 × 3G 2SI division 1080p IP output signals
 - 4 × 3G square division 1080p IP output signals
 - 1 × 12G single-stream 2160p IP output signal
- Send full ancillary space on one SMPTE 2110-40 metadata stream (**Meta 1**)
- Send 4 audio streams (**Audio 1 to Audio 4**)
 - Audio 1 can send up to 64 audio channels
 - Audio 2 to 4 can send up to 64 audio channels, but only audio channel 1 to 16 are passed through. Audio channels 17 to 64 will contain silence.

Statuses confirm that the RTP stream is successfully streaming.

The configuration of the **GB2** tab is the same as the **GB1** tab. Only the configuration of the **GB1** tab is shown below.

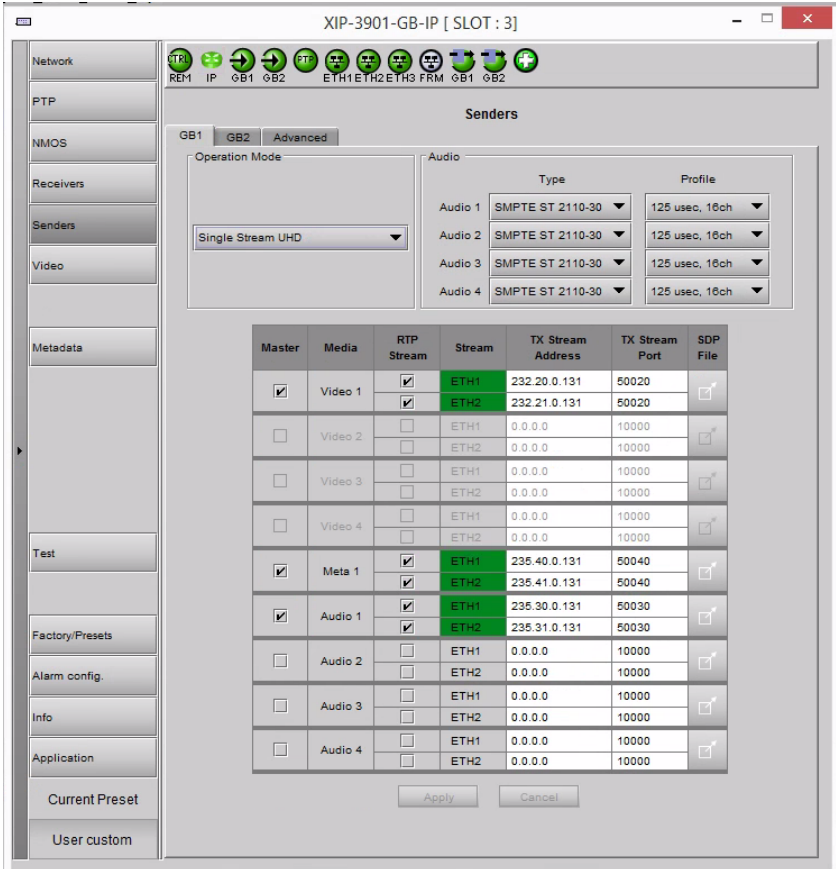

Figure 10-3: Senders GB1 / GB2 Tab

Property	Description
Operation Mode	<p>Quad Stream UHD 2SI Division: Sends 4 × 3G 2SI division 1080p IP output signals.</p> <p>Quad Stream UHD Square Division: Sends 4 × 3G square division 1080p IP output signals.</p> <p>Single Stream UHD: Sends 1 × 12G single-stream 2160p IP output signal.</p>
Audio	<p>Type: Use the pull-down to set the audio stream's type for streams Audio 1 to Audio 4.</p> <ul style="list-style-type: none"> • Type SMPTE ST 2110-30: for PCM linear audio (AES67 compatible) • Type SMPTE ST 2110-31: for transparent transport of non-linear audio and data formats. Provides bit-transparent AES3 over IP. <p>Profile: Use the pull-down to set audio profile for streams Audio 1 to Audio 4. Audio senders support Level C as per SMPTE 2110-30/31: 48kHz stream from 1 to 8 channels (1 to 4 for SMPTE 2110-31) at packet times of 1ms and 1 to 64 channels (1 to 60 for SMPTE 2110-31) at packet time of 125us.</p> <p>For Audio 2 to Audio 4, only the first 16 channels will carry active audio and channels 17-64 will carry silence.</p> <p>These settings can also be managed by external NMOS control. See NMOS Panel, on page 239.</p>
Master	Set to enable a media sender. This manages both the primary and secondary streams. This can also be managed by external NMOS control. See NMOS Panel , on page 239.
Media	Shows the stream type.
RTP Stream	Set to enable a media stream sender for primary and secondary. This can also be managed by external NMOS control. See NMOS Panel , on page 239.
Stream	<p>Shows the primary (ETH1) and secondary (ETH2) streaming status:</p> <p>Green: streaming</p> <p>Red: not streaming</p> <p>Grey: not active</p> <p>When the Operation Mode is Quad Stream UHD 2SI Division or Quad Stream UHD Square Division, the streams for Video 1 to Video 4 should be green.</p> <p>When the Operation Mode is Single Stream UHD, the streams for Video 1 should be green and the streams for Video 2 to Video 4 should be grey.</p>
TX Stream Address	Set the IP address and UDP port number of the outgoing stream. IP address 0.0.0.0 disables a sender. The default UDP port values are 10000.
TX Stream Port	Address & UDP port can also be managed by external NMOS control. See NMOS Panel , on page 239.
SDP File	Click to show the last SDP file transmitted through NMOS since the last bootup. This window does not refresh automatically; you need to close and re-open the window to see an update. If the card has never received an SDP file since its last bootup, the window will be empty.
Apply Cancel	When active, this applies or rejects your current changes made in this tab except for Audio Type and Audio Profile

Advanced Tab

This tab allows you to configure the outgoing payload type and DSCP priority for SMPTE 2110-20 (Video), SMPTE 2110-40 (Meta 1) and SMPTE 2110-30/31 (Audio 1 to Audio 4). These settings apply to both **GB1** and **GB2** tabs.

The XIP-3901-GB-IP's **Senders Panel, Advanced** tab configuration is the same as the XIP-3901-UDC-IP's IP's **Senders Panel, Advanced** tab configuration; see [Advanced Tab](#), on page 145.

Video Panel

The Video panel has two tabs (**GB1** and **GB2**); one for each of XIP-3901-GB-IP's independent processing channels. The configuration of the **GB2** tab is the same as the **GB1** tab. Only the configuration of the **GB1** tab is shown below.

Timing Tab

For each processing channel, you can adjust the timing relative to the reference. Use the slider or type a value into the data box on the right of the slider. Metadata and audio streams will match the video delay set below.

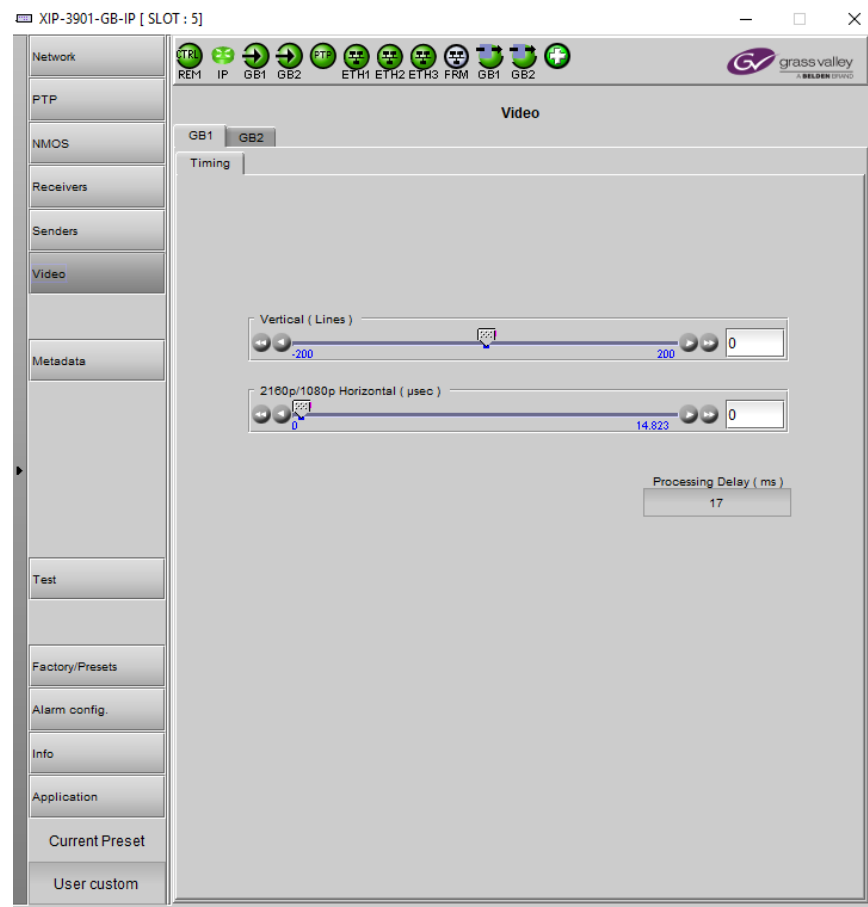

Figure 10-4: Video Timing Tab

The following adjustment sliders are available:

Adjustment	Range (50 Hz)	Range (59 Hz)	Description
Vertical (Lines)	200 to +200	200 to +200	Vertical setting applies to all output formats.
2180p/1080p Horizontal (msec)	0 to 17.771 msec	0 to 14.825 msec	Horizontal settings are specific to individual output formats.

This section also displays the Processing Delay in microseconds so you can manage the processing delay on your system.

The XIP-3911 and XIP-3901 has an integrated frame sync that supports synchronous and asynchronous input signals. The input signals will be synchronized and realigned to PTP.

The frame sync behaves like a frame buffer. It also supports frame skips/repeats in the case of an asynchronous SDI input. When an input error occurs, it freezes to the last valid field/frame.

- 1 On a skip/repeat frame, PCM audio will take up to 15 seconds to track. For non-PCM audio, it will instantly catch-up.
- 2 On skip/repeat frame, metadata is skipped or duplicated.
- 3 On freeze, audio is muted and metadata is blanked

The following table shows the amount of time for a vertical line.

Input Video Format	Output Video Format	Line length	Description
3840x2160p 59Hz	3840x2160p 59Hz	14.825 μ sec	Frame rate follows detected input video format
3840x2160p 50Hz	3840x2160p 50Hz	17.771 μ sec	

Metadata Panel

The XIP-3901-GB-IP manages the transfer of metadata between its input and output, but does not process the metadata information regarding the video conversion. In the Metadata Panel, you can selectively pass or block any one of eight specific ANC data types by specifying the DIDs and SDIDs to be passed from input to output and those that are to be blocked.

The XIP-3901-GB-IP's **Metadata** Panel configuration is the same as the XIP-3901-UDC-IP's **Metadata** Panel configuration; see [Metadata Panel](#), on page 161.

Test Panel

You may activate the Color Bars & Tone test signal for the two channels independently by enabling the appropriate checkboxes.

The XIP-3901-GB-IP's **Test** Panel configuration is the same as the XIP-3901-UDC-IP's **Test** Panel configuration; see [Test Panel](#), on page 174.

11

Common Configuration iControl Panels

XIP-3901-UC, XIP-3901-DC, or XIP-3901-FS	XIP-3901-UDC-IP	XIP-3901-UDC-IF	XIP-3901-GB-IP	XIP-3901-JPEG XS	XIP-3901-ASI
●	●	●	●		

Factory/Presets Panel

This panel provides access to three functions, which apply only to the current application (unlike the restore point, which saves the settings for all applications on the platform).

- User Presets. See [User Presets](#), on page 250.
- Factory. See [Load Factory button](#), on page 251.
- Profiles. See [Profiles](#), on page 251.

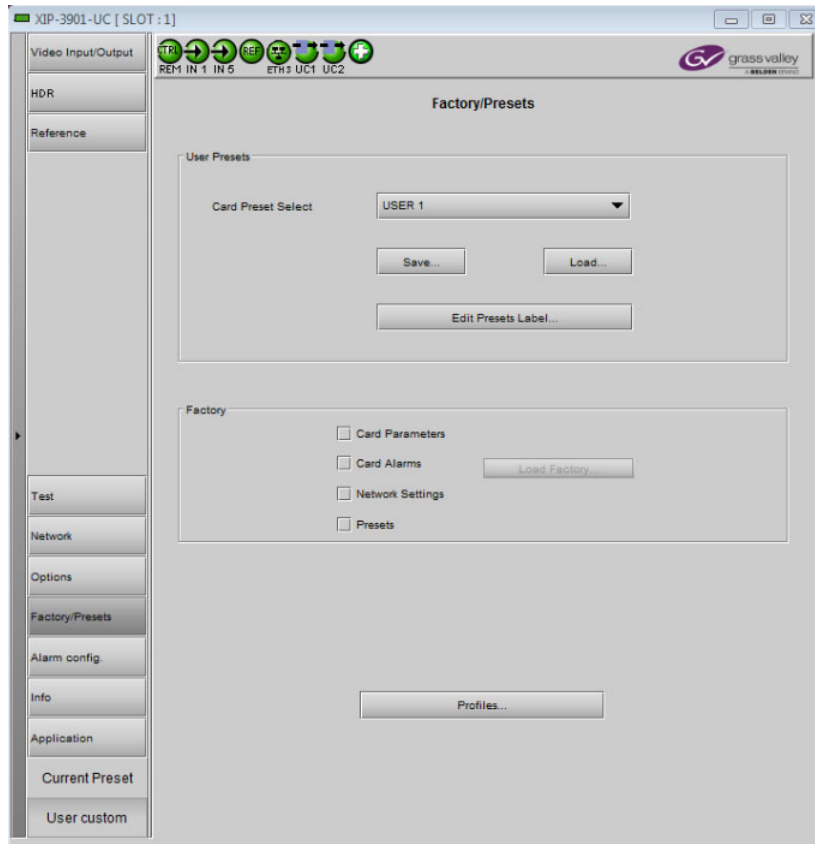

Figure 11-1: Factory/Presets Panel (Shown on XIP-3901-UC)

At the bottom left of the window, the Current Preset field displays the presets that are currently used on the XIP-3901 application. Possible values are:

- Factory default
- User defined presets (for example, USER 1)
- User custom (when a setting has been modified from a defined preset or factory default settings)

User Presets

Each XIP-3901 application has memory registers that can hold up to five user-defined parameter settings.

Select any one of the five presets using the Card Preset Select pulldown menu.

Click **Load** to load the contents of the selected user preset into the XIP-3901 application. All parameter settings and values will be replaced by the contents of the selected user preset.

A confirmation box will pop up to allow you to proceed or cancel the load.

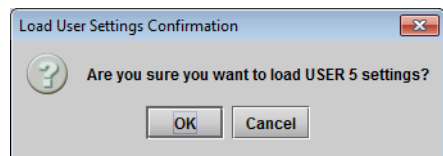

Figure 11-2: Load User Settings Confirmation Box

Click **Save** to store the current parameter settings and values from the XIP-3901 application in the selected user preset. The existing contents of the preset will be overwritten. A confirmation box will pop up to allow you to proceed or cancel the save.

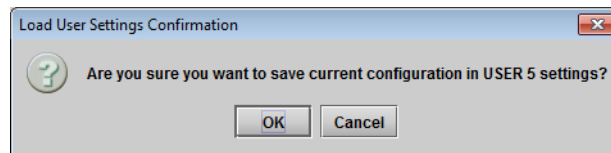

Figure 11-3: Save Configuration Confirmation Box

You can edit the name assigned to each user preset.

- Click **Edit Presets Label** to open the Presets window.
- Double-click on a name in the Label column.
- Type a new name in the window.
- Click **OK**.

The text you have entered (up to 16 characters) will be appended to the label name in the pulldown menu.

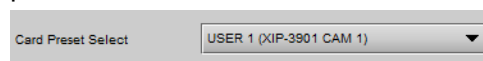

Figure 11-4: Card Preset Select

Load Factory button

Clicking the Load Factory button will restore the card to a factory default state. Four checkboxes can be used to choose whether to include card parameters, card alarms, network settings and presets in the restoration process.

Note: Card alarms are reset to factory values; iControl alarms and GSM alarms are not reset. With reference to the Alarm Configuration panel:

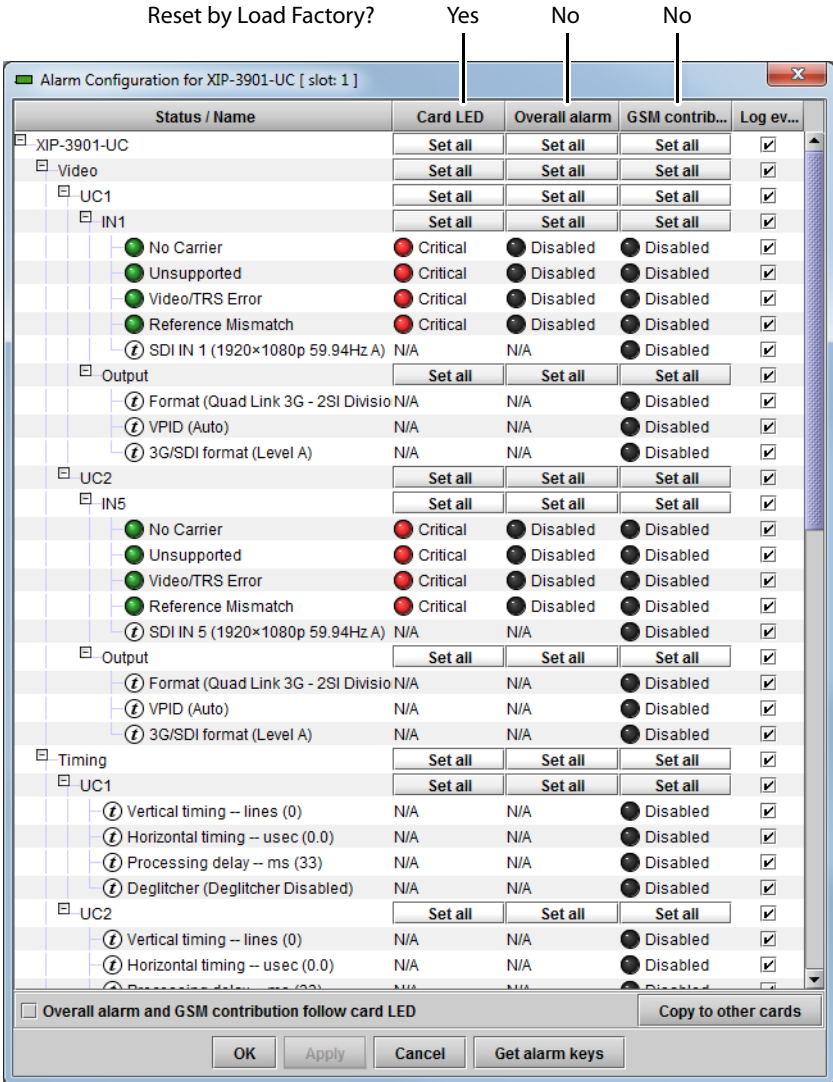

Figure 11-5: Alarm Types Reset by Load Factory (Shown on XIP-3901-UC)

Profiles

Use Profiles to save or recover the entire card configuration (including user presets if desired) on an external disk, or to copy it to another XIP-3911 or XIP-3901 card located in any Densité frame in the system.

Click **Profiles** to open the Profile Copy window.

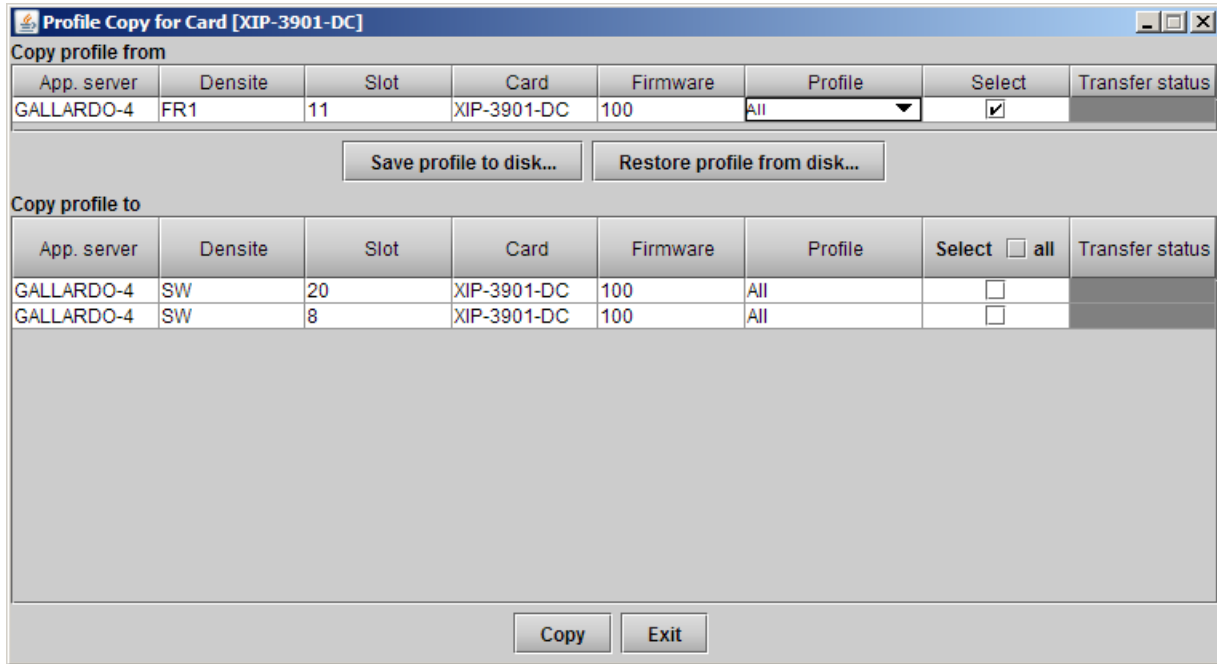

Figure 11-6: Profile Copy for Card (Shown on XIP-3901-DC)

Copy profile from

This line shows the XIP-3901 card and its App. server, Densité frame, slot number, card type, firmware version and profile.

The Profile column has a pulldown menu that allows you to select from the following options:

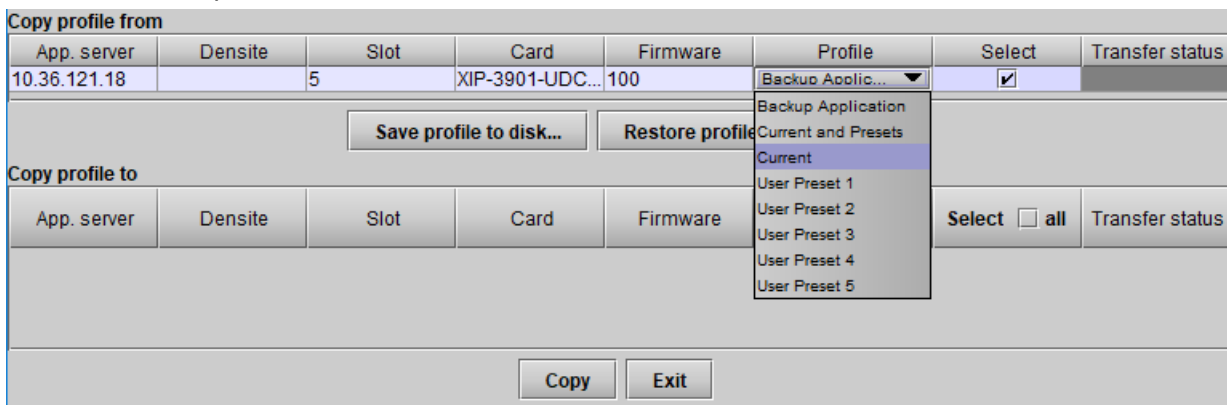

Figure 11-7: Profile Column Pulldown Menu

Property	Description	Profile Option Saves	
		Card Parameters	Receivers / Senders Configuration, Alarms, NMOS, PTP, and Ethernet / Network
Backup Application	The card's current configuration and all presets will be copied or saved to disk.	●	●
Current and Presets	Part of the current configuration and presets will be copied or saved to disk.	●	
Current	Only the card's current configuration will be copied or saved on disk.	●	
User Presets 1 - 5	Only the selected preset will be copied or saved on disk.	●	

The Select column includes a checkbox (pre-checked) to confirm that you want to work with the current card.

Save profile to disk...

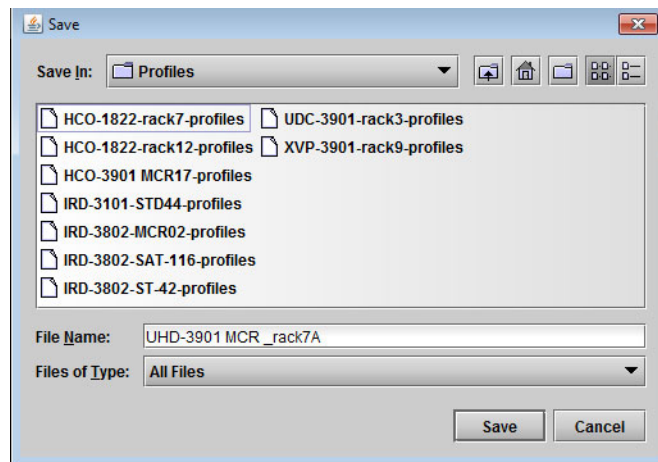

Figure 11-8: Save Profile to Disk Dialog

After selecting which profiles to save, click this button to open a Save dialog. Specify a file name and location to which the selected profiles for this card will be saved.

Note: It is a good idea to create a folder for these files, because they are not explicitly identified as XIP-3901 profiles and will be difficult to identify if not clearly named and conveniently located.

Click **Save** once the name and location have been identified in the Save box. The Transfer Status box on the right of the Copy profile from line will indicate In Progress against a yellow background.



If the file was saved correctly, the Transfer Status box will indicate Succeeded against a green background.

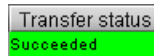

If the file was not saved for some reason, the Transfer Status box will indicate Failed against a red background.



Restore profile from disk...

Click this button to open an Open dialog box to locate and select a valid XIP3911 or XIP-3901 profile file.

- Click **Open** to read the contents of the file and reconfigure the XIP-3901's profiles accordingly.
- While the reconfiguration is in progress, the Transfer Status box on the right of the Copy profile from line will indicate Working against a yellow background.
- When the reconfiguration is complete, the Transfer Status box will indicate Succeeded against a green background.

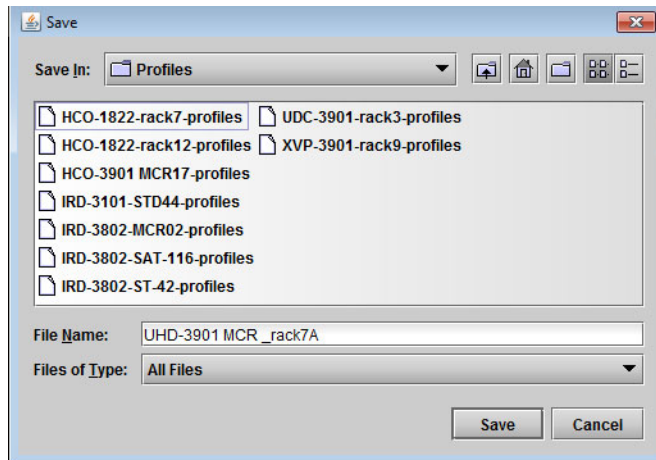

Figure 11-9: Save Profile to Disk Dialog

On a restore profile from disk, there is no need to select a profile type (ALL, Current, User1 to User5). All the profile contents of the file will be restored.

Copy profile to

This section shows other XIP3911 or XIP-3901 cards that are available on the iControl network, each identified by its app. server, Densité frame, slot number, card type and firmware version.

The **Profile** column shows the same setting as selected for the current card in the **Copy profile from** line. See [Profile Column Pulldown Menu](#), on page 252.

The Select column includes a checkbox to identify the XIP-3911 or XIP-3901 cards to which profiles will be copied from the current card.

- For convenience, a Select all checkbox is provided in the column header.

Click **Copy** to copy the selected profiles from this card into the selected other XIP-3911 or XIP-3901 cards.

- While the profile copy operation is in progress, the Transfer Status box on the right of the Copy profile to line will indicate Working against a yellow background.
- When the profile copy operation is complete, the Transfer Status box on the right of the Copy profile to line will indicate Succeeded against a green background.

Note: The source and destination cards must have the same firmware version. Any destination cards with a different firmware version that are shown in the Copy profile to list cannot be selected, and their transfer status is always N/A on a yellow background.

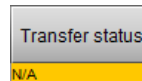

Alarm Config Panel

This panel is used to configure the alarm reporting of the XIP-3901 application. The panel opens in a new window when the button is clicked and can be resized.

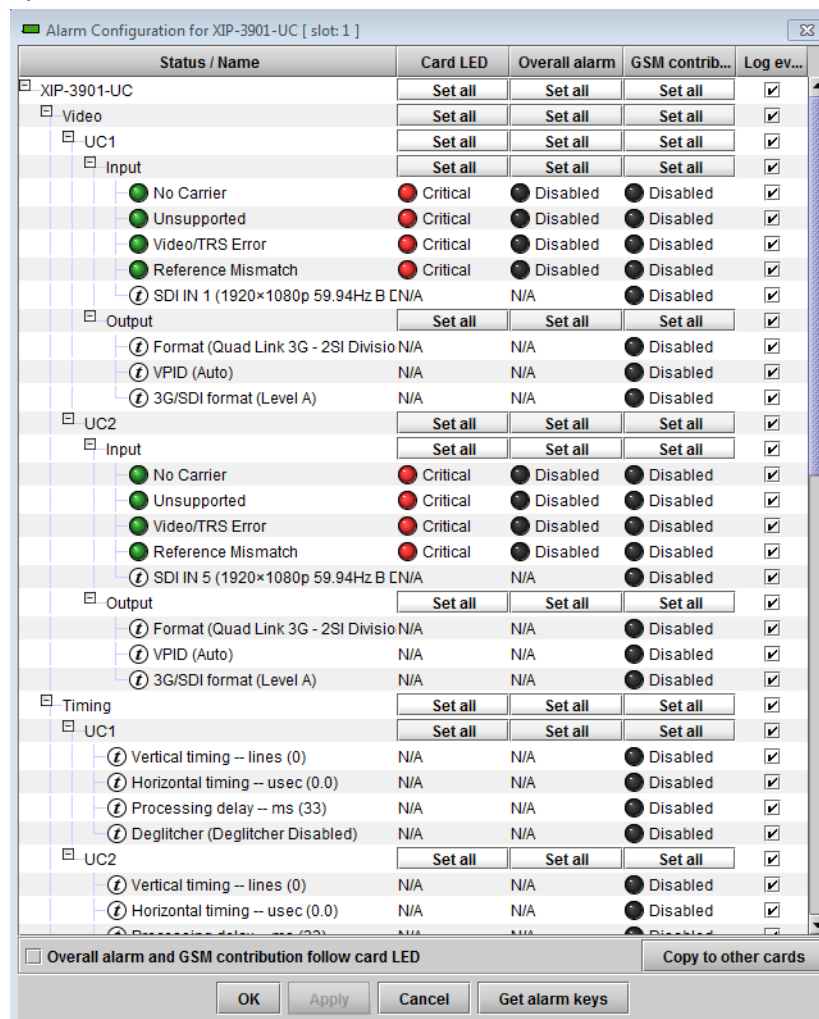

Figure 11-10: Alarm Configuration (Shown on XIP-3901-UC)

Status/Name

This column contains an expandable tree listing all the alarms reported by this XIP-3911 or XIP-3901 card.

- Each alarm name includes an icon that shows its current status.
- Some alarms may be text-only, and the alarm status is shown in the name and not by a status icon.

Card LED, Overall Alarm and GSM Contribution

These columns contain pulldown menus used to set the severity level of each individual alarm to the alarm named in the column heading. This can be set independently for Card LED, Overall Alarm and GSM Contribution.



Card LED

This column is used to set the severity level of the selected individual alarm to the status LED located on the front card-edge. The Card LED status is shown at the bottom of the alarm tree in the Status/Name column. If at least one Critical or Major alarm is triggered, the LED will change to red. If no Critical or no Major alarms are triggered and Minor alarms are occurring, the LED will change to yellow.

Overall Alarm

This column is used to set the severity level of each individual alarm to the Overall Alarm associated with the card. The Overall Alarm is shown in the upper left corner of the iControl panel and also appears at the bottom of the Status/Name column.

GSM Contribution





This column is used to set the severity level of each individual alarm to the GSM Alarm Status associated with this card. GSM is a dynamic register of all iControl system alarms and is also an alarm provider for external applications. The possible values for this contribution are related to the Overall Alarm contribution:

- If the Overall Alarm contribution is Disabled, the GSM alarm contribution can be set to any available value.
- If the Overall Alarm contribution is any level other than Disabled, the GSM contribution is forced to follow the Overall Alarm.

Log Events

iControl maintains a log of alarm events associated with the card. The log is useful for troubleshooting and identifying event sequences. Check the box to log alarm events for each individual alarm.

Levels associated with these alarms: The pulldown menus may contain some or all of the following settings:

 Disabled	The alarm makes no contribution (black icon)
 Minor	The alarm is of minor importance (yellow icon)
 Major	The alarm is of major importance (orange icon)
 Critical	The alarm is of critical importance (red icon)
 Passthrough	The alarm exists but has no effect (used for text and composite alarms)

Note: As a shortcut, you can click one of the Set All boxes beside a section heading to open a pulldown menu that lets you assign a level to all alarms in that section of the column simultaneously.

Once the alarms are configured, you may accept the changes or discard them:

Overall alarm and GSM contribution follow card LED

Check the box to force the Overall Alarm and GSM contribution to match the Card LED status.

- All Overall Alarms and GSM contributions for which there is a Card LED alarm will be forced to match the Card LED alarm.
- All Overall Alarms and GSM contributions for which there is no Card LED alarm will be forced to be Disabled.

A warning dialog box will open to ask you to confirm the action, since it will change the configuration and cannot be undone.

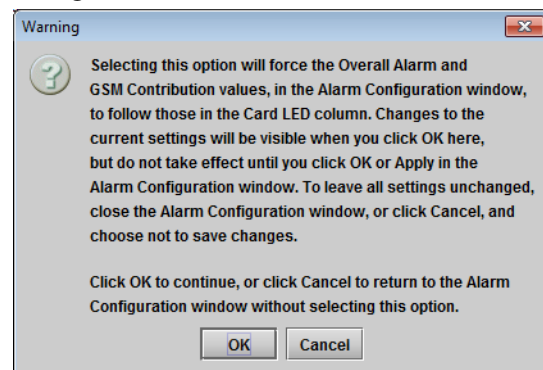

Figure 11-11: Warning for Follow LED Change

Copy to other cards

Click this button to open a panel that is used to copy the alarm configuration set for this card to another XIP-3911 or XIP-3901 card.

- Select one or more destination cards from the list in the window by checking the boxes, or check **All** to select them all.
- Note that when you copy a profile for the XIP-3911 or XIP-3901 card (see Profiles - Profiles), the alarm configuration is copied along with all the other settings.

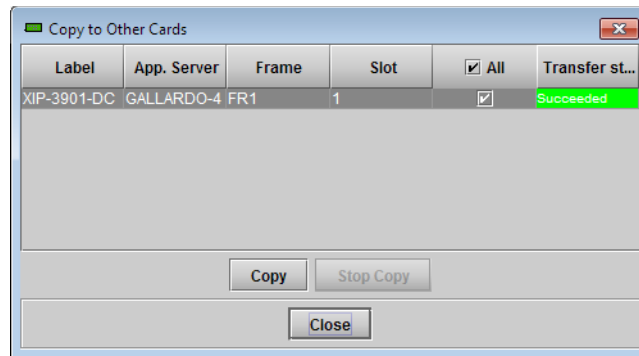

Figure 11-12: Copy to Other Cards Window

Get alarm keys

Click this button to open a save dialog where you can save a file containing a list of all alarms on this card and their current values, along with an alarm key for each. The alarm keys are useful for system integration and troubleshooting.

The file is saved in .csv format.

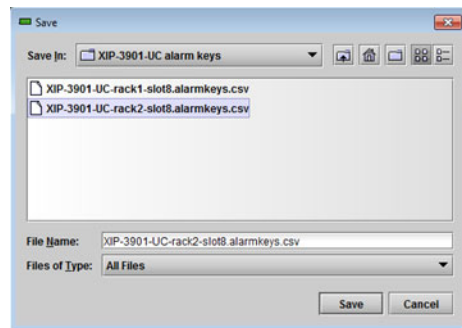

Figure 11-13: Get Alarm Keys Dialog

OK, Apply, Cancel

- **OK:** Accepts the settings and closes the window once the card confirms that there are no errors.
- **Apply:** Accepts the settings but leaves the window open.
- **Cancel:** Closes the window without applying any changes and leaves the previous settings intact.

Info Panel

When the XIP-3911 or XIP-3901 is included in an iControl environment, certain information about the card should be available to the iControl system. You can enter labels and comments that will make this card easy to identify in a complex setup. This information is entered into data boxes in the Info control panel.

- **Label:** Enter the label that appears for the XIP-3901 application in iControl applications.
- **Short label:** Enter the short-form label sometimes used by iControl (8 characters).

- **Source ID:** Enter a descriptive name for the XIP-3901 application.
- **Comments:** Enter any desired text.

The remaining data boxes show manufacturing information about the card.



Figure 11-14: Info Panel (Shown on XIP-3901-UC)

Three buttons in the panel give access to other information.

- **Details...:** Reports the service version and panel version for the card.



Figure 11-15: Details Window

- **Advanced...:** Shows the Long ID for this card. The Long ID is the address of this XIP-3901 application on the iControl network.

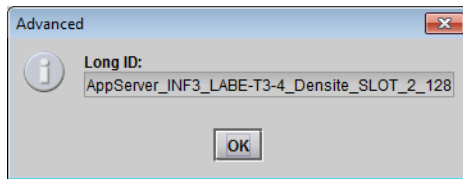

Figure 11-16: *Advanced Window*

- **Remote system administration...**: Opens the *Joining Locators* window, which lists the remote lookup services to which this XIP-3901 application is registered.

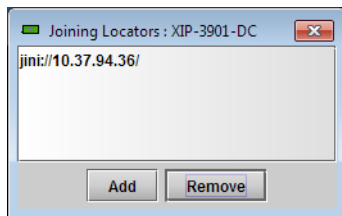

Figure 11-17: *Joining Locators Window*

Add: Force the iControl service for this XIP-3901 application to register itself on a user-specified Jini lookup service, using the following syntax in the data box:

jini://<ip_address>

where <ip_address> is the IP address of the server running the lookup service:

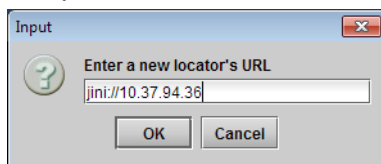

Figure 11-18: *Add Window*

Remove: Click to select one of the services listed in the window and click **Remove**. A confirmation dialog box will appear.

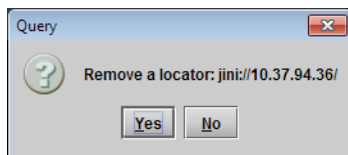
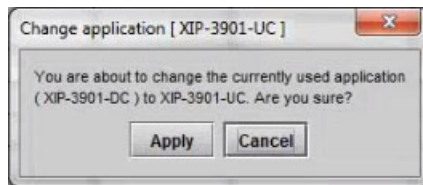

Figure 11-19: *Remove Window*

Once an application has been activated, it cannot be deactivated.

To switch to a different application:

- 1 Select the **In Use** radio button for the application you wish to use.
- 2 In the Change application dialog box, click **Apply**.
- 3 Wait several seconds for the application to reboot.



Getting Started with the Card's Web-based Configuration Interface

XIP-3901-UC, XIP-3901-DC, or XIP-3901-FS	XIP-3901-UDC-IP	XIP-3901-UDC-IF	XIP-3901-GB-IP	XIP-3901-JPEG XS, or XIP-3901-ASI
				•

Connecting to the XIP-3911 & XIP-3901 Card's Configuration Interface

Here are the ways to connect to the card's Web-based configuration interface:

- Through GV Orbit. GV Orbit will discover and show the XIP-3901-JPEG-XS or XIP-3901-ASI as any other application. The web page can be viewed through GV Orbit. You do not need to know the address of the card's control port.
- Through any web browser by typing:
 - the card's ETH3 control port IP address
 - the card's Hostname
 - the frame controller's Ethernet port (FRM) IP address, when the card is installed in a Densité 3+FR4 frame with a CPU-ETH3 Standard or Advanced controller¹

To set the card's IP address, see [Setting the Card's IP Addresses](#), on page 68. See also [Connections and Cabling](#), on page 63.

Downloading new XIP applications

XIP-3901 applications can be downloaded from the Grass Valley support site, under **Downloads for Broadcast Products** and look for **XIP-3901 Agile Modular SDI/IP Processing Platform for Densité 3+** to download latest applications.

This is a .ZIP file. Do not unzip the file for the following procedures.

Card Upgrade

Before configuring the card, install the latest firmware and applications onto the card to take advantage of the latest available features and stability enhancements. See [Downloading new XIP applications](#), on page 263.

1. The FRM port is a bridged port through the Densité frame controller. The physical frame controller's Ethernet port must be connected to the network for this interface to work. See [Connections and Cabling](#), on page 63.

Schedule this maintenance operation during off hours when the system is not in use.

There are the following scenarios to upgrade the card.

- The XIP-3901-JPEG-XS or XIP-3901-ASI is already installed (this application is listed on the application section). In this case, you perform the upgrade through the card's WEB page. See [Card Upgrade when the XIP-3901-JPEG-XS or XIP-3901-ASI Application is Currently Running on the Card](#), on page 264
- You have an XIP-3911 or XIP-3901 card, but the XIP-3901-JPEG-XS or XIP-3901-ASI application is not installed. In this case, you will have to install the XIP-3901-JPEG-XS or XIP-3901-ASI application through the Densité Update Manager (DUM) using a DUM package. This adds the application to the card. Then update XIP-3901-JPEG-XS or XIP-3901-ASI through its web page to the very latest software version. See [Card Upgrade when Another Application is Currently Running on the Card](#), on page 266

Card Upgrade when the XIP-3901-JPEG-XS or XIP-3901-ASI Application is Currently Running on the Card

Proceed as follows.

- 1 Connect to the card's configuration interface. See [Connecting to the XIP-3911 & XIP-3901 Card's Configuration Interface](#), on page 263.
- 2 Click **Upgrade** panel button.

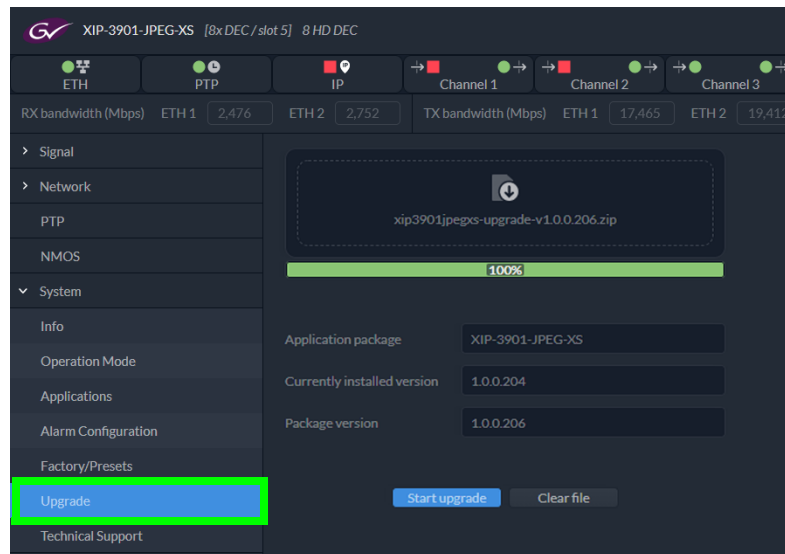

3 Click **Click** to choose an application package or drop it here.

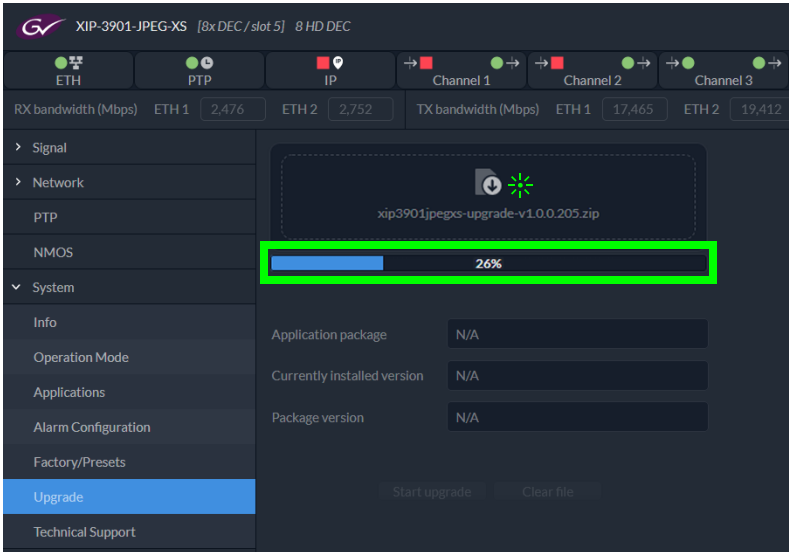

A **File Upload** window opens.

4 Find the upgrade package file on your PC and click **Open**.

The file is uploaded to the card. A progress bar shows the current upload status.

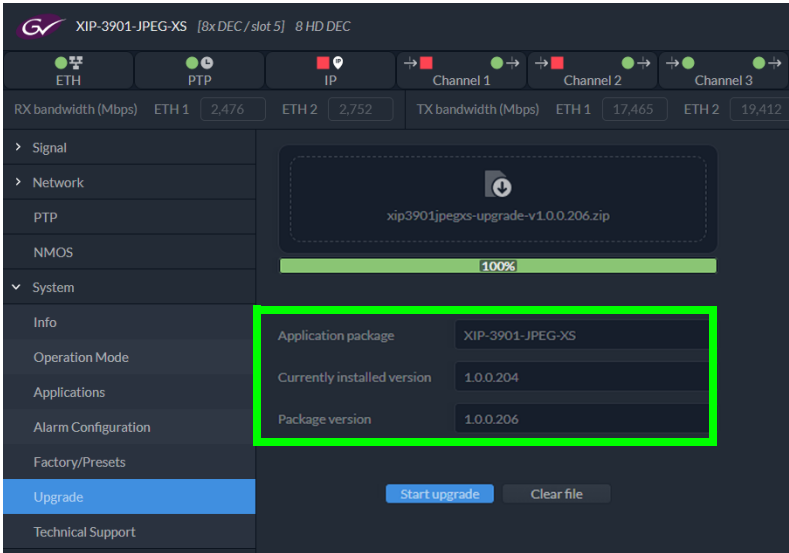

Once the upload is complete, the following fields are updated with information about the uploaded package.

Property	Description
Application package	Shows the application name of the uploaded package that is awaiting installation. NOTE: You can upgrade any application even if the application is not currently active.

Property	Description
Currently installed version	Shows the currently-installed firmware version for the application awaiting installation.
Package version	Shows the package version of the uploaded package that is awaiting installation.

- 5 Verify that the software version to be installed is the right one. If the wrong software package has been uploaded to the card, click **Clear File** to remove the uploaded package from the card. Otherwise, click **Start Upgrade**.

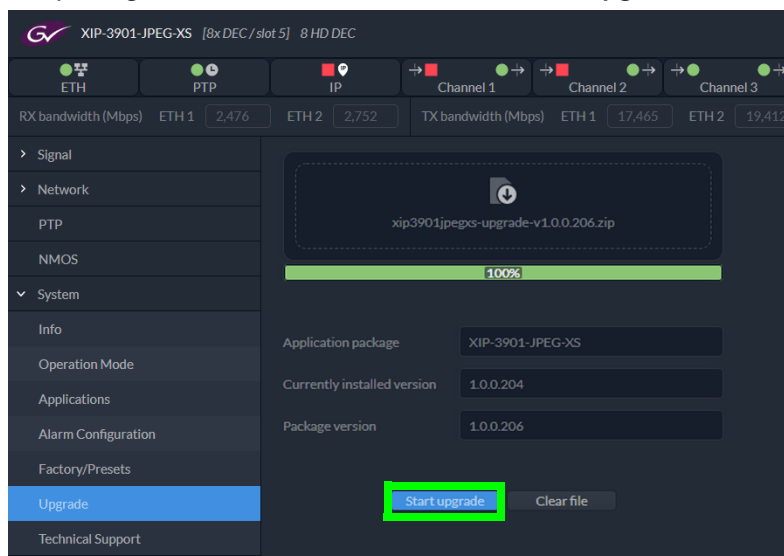

Once the software upgrade complete, the card reboots. The software is added to / updates the Applications list. Applications must be licensed before use. See [Applications Panel](#), on page 300.

- 6 Ensure the XIP-3901-JPEG-XS or XIP-3901-ASI application is licensed. See [Activating an Application](#), on page 300.

Card Upgrade when Another Application is Currently Running on the Card

When a non-XIP-3901-JPEG-XS application is currently running on the card, you need to first change the card's application to the XIP-3901-JPEG-XS application and then upgrade the card's firmware.

Proceed as follows.

- 1 If the XIP-3901-JPEG-XS application has never been installed on the card, you need to Install the XIP-3901-JPEG-XS application through the Densité Update Manager (DUM) using a DUM package. See [Card Upgrade with iControl Solo](#), on page 71.
- 2 Change the card's current application to XIP-3901-JPEG-XS. See [Application Panel](#), on page 261.
- 3 Connect to the card's configuration interface. See [Connecting to the XIP-3911 & XIP-3901 Card's Configuration Interface](#), on page 263.

- 4 Ensure the XIP-3901-JPEG-XS application is licensed. See [Activating an Application](#), on page 300.
- 5 Update the card's application through the card's web page. See [Card Upgrade when the XIP-3901-JPEG-XS or XIP-3901-ASI Application is Currently Running on the Card](#), on page 264. This is important in order to have the latest features, stability enhancements, and bug fixes.

Card's Web-based User Interface Overview

XIP-3901-UC, XIP-3901-DC, or XIP-3901-FS	XIP-3901-UDC-IP	XIP-3901-UDC-IF	XIP-3901-GB-IP	XIP-3901-JPEG XS, or XIP-3901-ASI
				●

The XIP-3901 applications can be remotely controlled using your PC's web browser. This manual describes the control panels associated with the XIP-3901 web-based applications and their use.

The basic configuration interface structure is shown in [Typical XIP-3901 Web Interface](#), on page 268. The interfaces for all web-based applications essentially follow the same structure. The window title bar shows the card type and the slot number where the card is installed in its Densité frame.

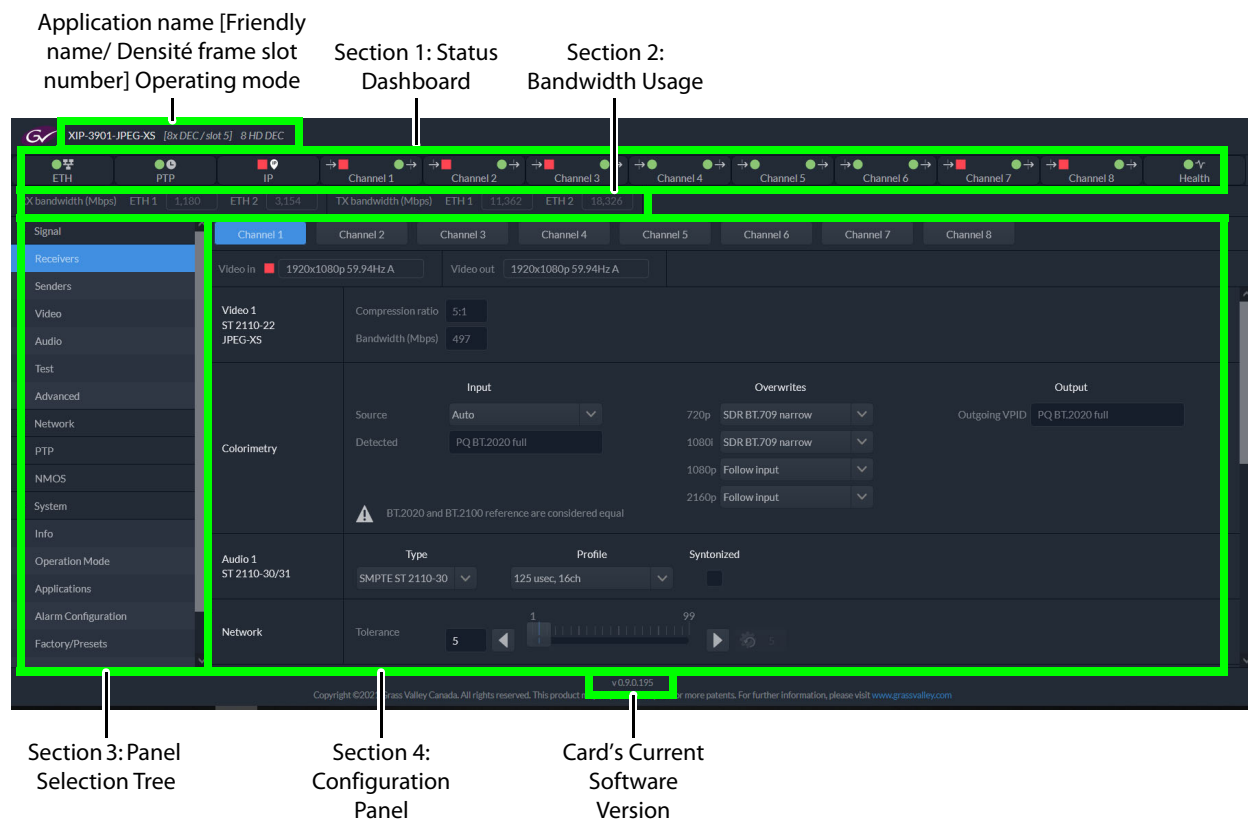

Figure 12-1: Typical XIP-3901 Web Interface

Section 1: Status Dashboard

The dashboard shows icons that report different statuses, such as IP statuses, Input/Output statuses and Health status.

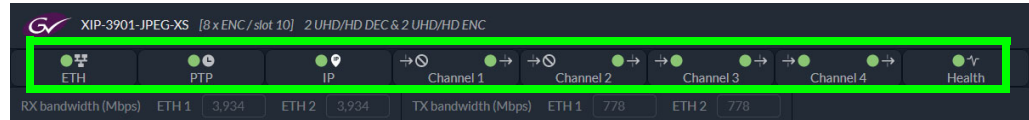

Figure 12-2: Typical XIP-3901-JPEG-XS Status Icons

Channel names can be customized with the **Friendly Names** parameters; see [Info Panel](#), on page 299.

Mousing over an icon will display a status message with additional information.

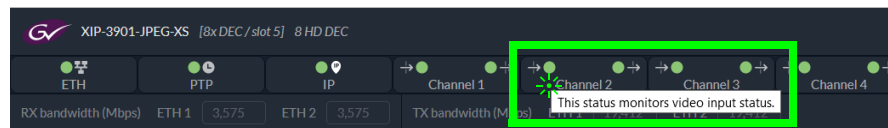

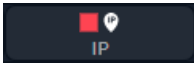
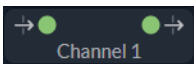
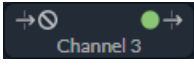
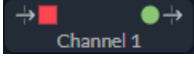
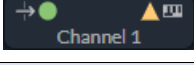
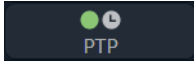

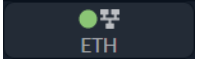







Figure 12-3: Typical XIP-3901 Status Message (mouse over a status icon)

The table below describes the various status icons that can appear. If there is an error, a status message is shown in a popup. See [Card Status Messages](#), on page 273.

Status Icon	Description
Media Network	
 (green)	No IP status error.
 (red)	At least one IP status is in error. For example: <ul style="list-style-type: none"> Receiver Stream, Media, and redundancy statuses, see: Receivers Panel, on page 278 Sender Stream statuses, see: Senders Panel, on page 283 NMOS IS-04 Registration status, see: NMOS Panel, on page 297
Channel Input / Output Status	
	Input: Video input status is OK Output: Video output is active. Test pattern is disabled.
	Input: Video receiver is disabled Output: Video output is active
	Input: Video Input status in error Output: Video output is active
	Input: Video input status is OK Output: Test Pattern is enabled (Color Bars & Tone) See also Test Panel , on page 289.
PTP Status	
	The card is locked to the network's PTP.

Status Icon	Description
	The card is not locked to the network's PTP. For more details on the problem(s), See PTP Panel , on page 295.
Network Status (ETH1/ETH2/ETH3/FRM)	
	Network linkup and active.
	No network link (port down).
	Network port is disabled.
	Network connections in progress.
Health Monitoring	
	Hardware OK.
	Hardware failure detected. If this icon is flashing red, call Technical Support.

Section 2: Bandwidth Usage

This shows the real-time receive and transmit bandwidth usage on the card's ETH1 and ETH2 network interfaces. See [Connections and Cabling](#), on page 63.

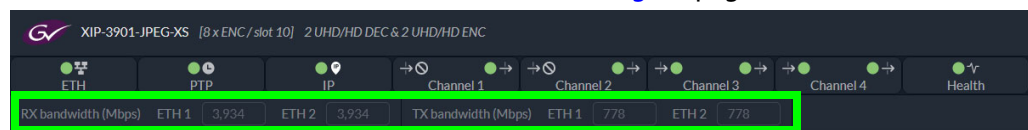



Figure 12-4: Typical XIP-3901 Bandwidth Usage Information

You must ensure that your configuration never allows the card's input or output bandwidth to be oversubscribed.

When the XIP-3901's maximum input or output bandwidth is oversubscribed (total streams require more than the available bandwidth of the SFP cartridge or network capacity), the symptoms are that of packet loss: missing blocks of video, audio dropout, and random loss of ancillary data on both processing channels. For compressed streams, symptoms can include total loss of the video streams on both processing channels.

Section 3: Panel Selection Tree

Click a button in the left portion of the window to select a configuration panel. The button is highlighted when it is selected. Click  in the tree to open the tree structure.

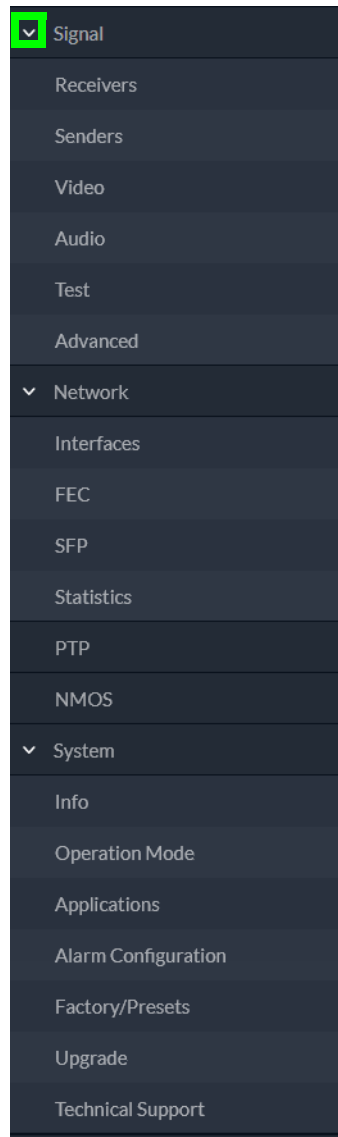

Figure 12-5: Configuration Panel Selection Tree

See also [XIP-3901-JPEG-XS Panel Selection Tree](#), on page 277.

Section 4: Configuration Panel

This main section displays the panel selected in Section 2. It may contain multiple tabs to access any appropriate sub-panel.

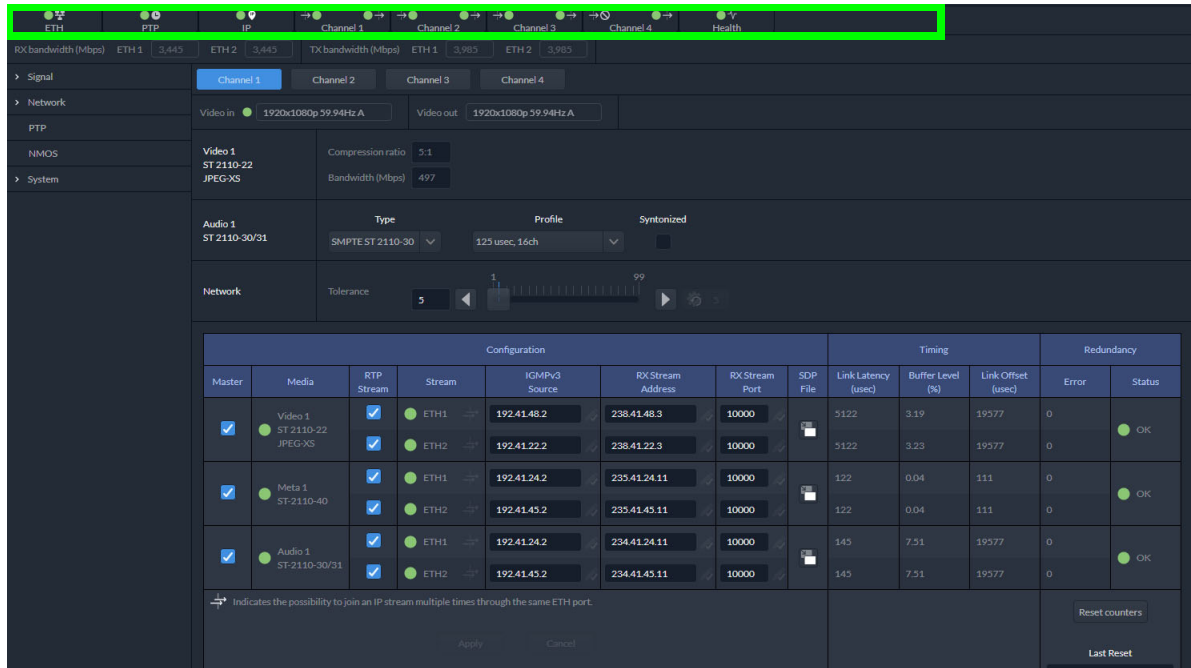

Figure 12-6: Typical Panel Display (Shown on XIP-3901-JPEG-XS)

Using the Channel Selector

The channel selector allows you to select one of the card's independent processing channels to be configured.

The channel selection is retained as you navigate from configuration panel to panel. First select a panel (see [Section 3: Panel Selection Tree](#), on page 271) and then select a channel at the top of the panel. Once a channel has been selected, the selection is maintained until you change it to another channel.

Card Status Messages

Toast status messages show the card's errors and warnings, for example:

- You try to set an out of range value
- Lost communication / reconnection with the card

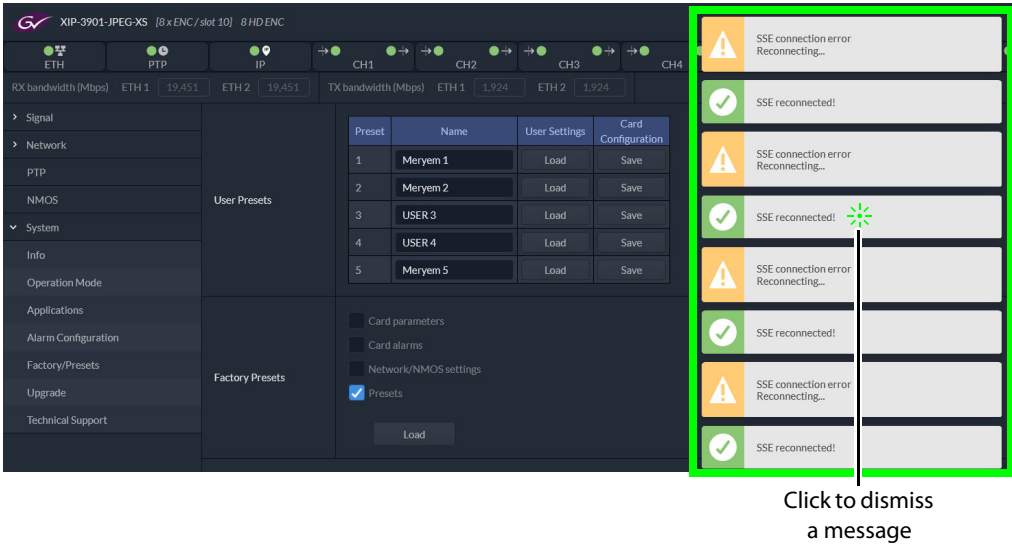

Figure 12-7: Typical Card Status Messages

Status message color	Description
Yellow	A warning or non-critical fault.
Red	An error occurred.
Green	Issue resolved.

To clear all messages at once, click on your browser's refresh button.

XIP-3911 or XIP-3901 Card Application Configuration

To Configure	Configuration Interface		See
	iControl	Web Browser	
XIP-3901-UC, XIP-3901-DC, or XIP-3901-FS	●		Configuring the XIP-3901-UC / -DC / -FS Applications with iControl , on page 85
XIP-3901-UDC-IP	●		Configuring the XIP-3901-UDC-IP v1.2 Application with iControl , on page 125
XIP-3901-UDC-IF	●		Configuring the XIP 3901-UDC-IF v4.0 Application with iControl , on page 179

Getting Started with the Card's Web-based Configuration Interface

XIP-3911 or XIP-3901 Card Application Configuration

To Configure	Configuration Interface		See
	iControl	Web Browser	
XIP-3901-GB-IP	●		Configuring the XIP-3901-GB-IP Application with iControl , on page 239
XIP-3901-JPEG-XS		●	Configuring the XIP 3901-JPEG-XS v1.0 Application with its Web Interface , on page 275
XIP-3901-ASI		●	Configuring the XIP 3901-ASI v1.0 Application with its Web Interface , on page 307

13

Configuring the XIP 3901-JPEG-XS v1.0 Application with its Web Interface

XIP-3901-UC, XIP-3901-DC, or XIP-3901-FS	XIP-3901-UDC-IP	XIP-3901-UDC-IF	XIP-3901-GB-IP	XIP-3901-JPEG XS	XIP-3901-ASI
				●	

This section describes the control panels associated with the XIP-3901-JPEG-XS application and its use.

Setting the Card's Operation Mode

The first step to configure an XIP-3901-JPEG-XS is to set the card's **Operation Mode**.

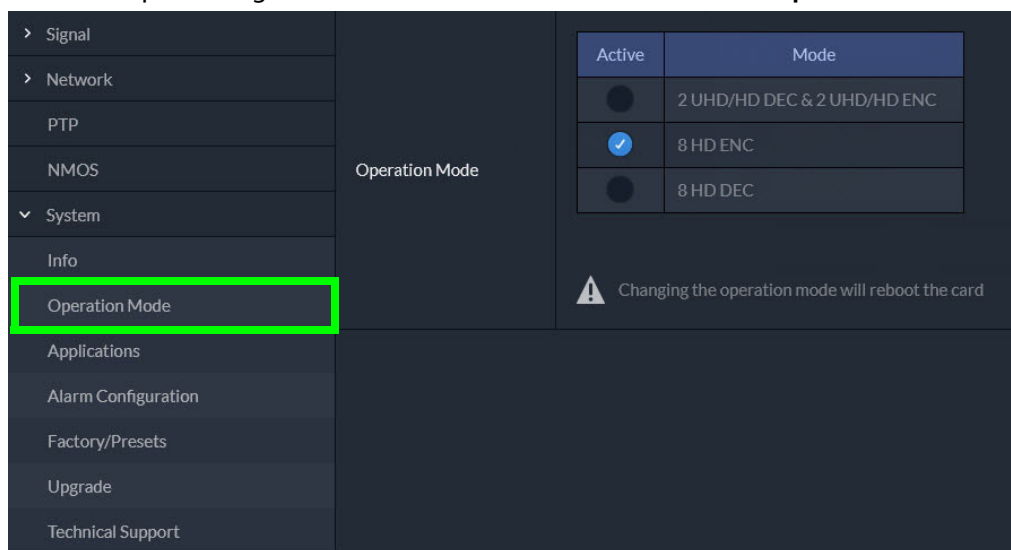
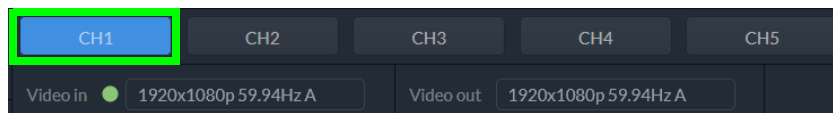

Figure 13-1: Factory/Presets Panel

Property	Description
Operating Mode	<p>Set the XIP-3901-JPEG-XS card's operating mode.</p> <p>2 UHD/HD DEC & 2 UHD/HD ENC: Two UHD or HD decode channels to decompress JPEG-XS encoded streams, plus two UHD or HD encode channels to create JPEG-XS compressed streams.</p> <p>8 HD ENC: Eight HD encode channels to create JPEG-XS compressed streams.</p> <p>8 HD DEC: Eight HD decode channels to decompress JPEG-XS encoded streams.</p>

Processing Channel Selection and Video In and Video Out

The XIP-3901-JPEG-XS has either four or eight **Channel** tabs, depending on the card's **Operation Mode** setting. Select a channel to configure it.

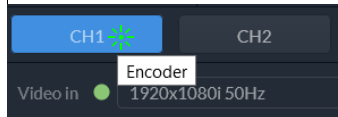

Property	Description
CHn This may display as a customized name for the channel.	<p>Click a Channel tab to access the configuration of any one of the XIP-3901-JPEG-XS's independent processing channels.</p> <ul style="list-style-type: none"> • 2 UHD/HD DEC & 2 UHD/HD ENC: The configuration of the Channel 2 tab is the same as the Channel 1 tab. The configuration of the Channel 4 tab is the same as the Channel 3 tab. • 8 HD ENC and 8 HD DEC: The configuration of the Channel 2 to Channel 8 tabs are the same as the Channel 1 tab. <p>Once a channel has been selected, it will not change when navigating to other configuration panels.</p> <p>Hover your mouse over any channel for a hint appear to show if a channel is configured as an Encoder or Decoder.</p>  <p>Channel names can be customized with the Friendly Names parameters; see Info Panel, on page 299.</p>
Video In Video Out	<p>Shows the current input and output video formats for this channel.</p> <p>Video In has a status indicator for the video input:</p> <p>Green: Video input valid and supported</p> <p>Red: Video in error or video format not supported</p> <p>Grey: video receiver disabled</p> <p>Hover your mouse over the Video In status indicator for a hint appear to see more details.</p>

XIP-3901-JPEG-XS Panel Selection Tree

Click an entry in the panel selection tree to view the configuration panel. For more information about the panel selection tree, see also [Section 3: Panel Selection Tree](#), on page 271.

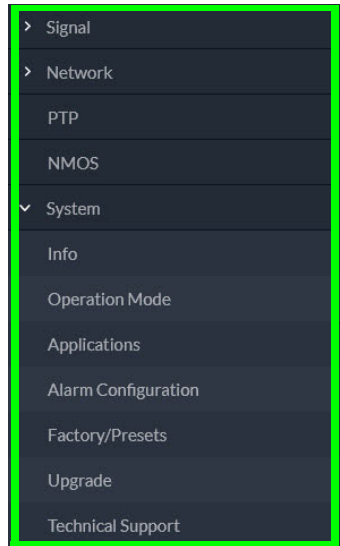

Figure 13-2: XIP-3901-JPEG-XS Panel Selection Tree

For more information about the configuration panels, see:

- [Receivers Panel](#), on page 278
- [Senders Panel](#), on page 283
- [Video Panel](#), on page 285
- [Audio Panel](#), on page 288
- [Test Panel](#), on page 289
- [Advanced Panel](#), on page 290
- [Interfaces Panel](#), on page 291
- [FEC Panel](#), on page 293
- [SFP Panel](#), on page 294
- [Statistics Panel](#), on page 295
- [PTP Panel](#), on page 295
- [NMOS Panel](#), on page 297
- [Info Panel](#), on page 299
- [Setting the Card's Operation Mode](#), on page 275
- [Applications Panel](#), on page 300
- [Alarm Configuration Panel](#), on page 302
- [Factory/Presets Panel](#), on page 304
- [Upgrade Panel](#), on page 305
- [Technical Support Panel](#), on page 305

Receivers Panel

These signals are available at the rear panel connectors. See [Summary of Rear Panel Connections](#), on page 50.

For a JPEG-XS Encoder Channel:

This panel allows you to configure the expected source media's stream address, port, and IGMPv3 source. The receiver is SMPTE ST 2110-20 (**Video 1**).

Statuses confirm that the RTP stream has successfully joined.

Configuration								Timing			Redundancy	
Master	Media	RTP Stream	Stream	IGMPv3 Source	RX Stream Address	RX Stream Port	SDP File	Link Latency (usec)	Buffer Level (%)	Link Offset (usec)	Error	Status
<input checked="" type="checkbox"/>	Video 1 ST 2110-20	<input checked="" type="checkbox"/>	ETH1	0.0.0.0	238.41.24.11	10000		608	5.92	5000	0	OK
		<input checked="" type="checkbox"/>	ETH2	0.0.0.0	238.41.45.11	10000		597	5.91	5000	0	OK

⚡ Indicates the possibility to join an IP stream multiple times through the same ETH port.

Buttons: Apply, Cancel, Reset counters, Last Reset (N/A)

Figure 13-3: Receivers Encoder Panel

For a JPEG-XS Decoder Channel:

This panel allows you to configure the expected source media’s video, metadata, and audio channels, stream address, port, and IGMPv3 source. The receivers are SMPTE ST 2110-22 (**Video 1**), ST 2110-40 (**Meta 1**), and ST 2110-30/31 (**Audio 1**).

Statuses confirm that the RTP stream has successfully joined.

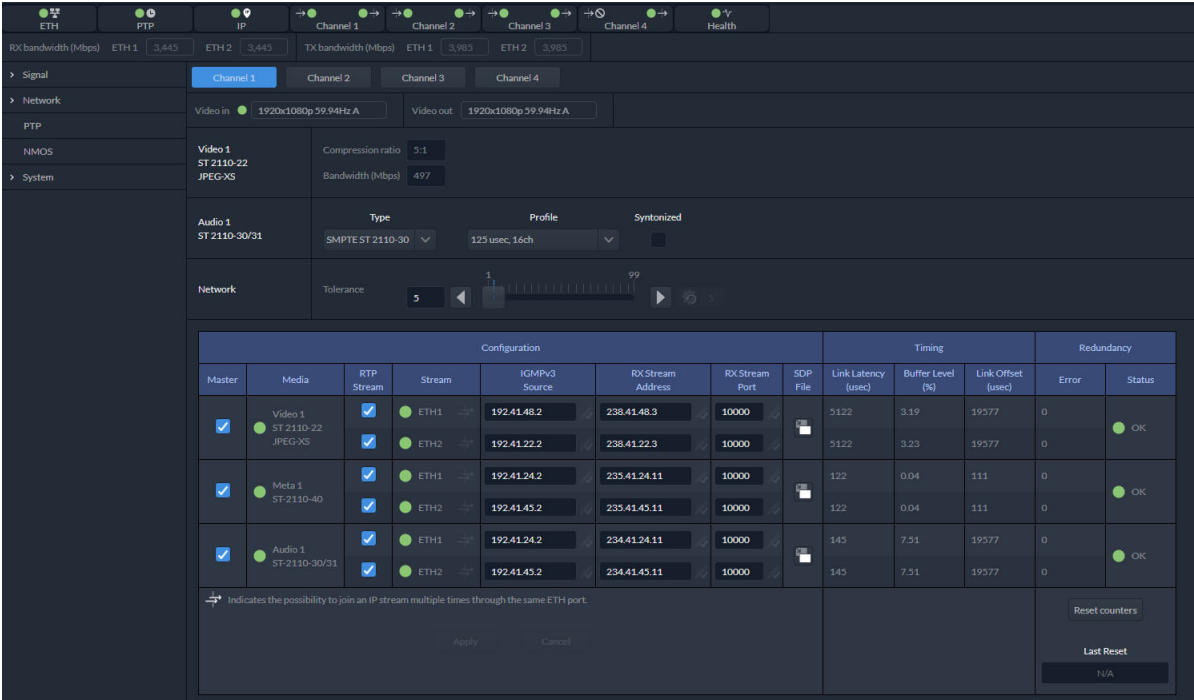









Figure 13-4: Receivers Decoders Panel

Property	ENC	DEC	Description
Video 1 ST 2110-22 JPEG-XS		<ul style="list-style-type: none"> When this channel is decoding a JPEG-XS video stream only: Compression ratio: Shows the current JPEG-XS video compression ratio set by the encoder. Bandwidth (Mbps): Shows the current JPEG-XS video stream bandwidth usage. 	

Property	ENC	DEC	Description
Audio 1 ST 2110-30/31		•	<p>When this channel is decoding a JPEG-XS video stream only:</p> <p>Type: Use the pull-down to set the audio stream's type for streams Audio 1.</p> <ul style="list-style-type: none"> • Type SMPTE ST 2110-30: for PCM linear audio (AES67 compatible) • Type SMPTE ST 2110-31: for transparent transport of non-linear audio and data formats. Provides bit-transparent AES3 over IP. <p>Profile: Use the pull-down to set audio profile for streams Audio 1. Audio senders support Level C as per SMPTE 2110-30/31: 48kHz stream from 1 to 8 channels (1 to 4 for SMPTE 2110-31) at packet times of 1ms and 1 to 16 channels at packet time of 125us.</p> <p>These settings can also be managed by external NMOS control. See NMOS Panel, on page 297.</p> <p>Syntonized: Set to ignore Audio RTP timestamps. Audio buffer reception is then set to 64ms. Use these settings to manage audio streams that are not properly time stamped.</p>
Network / Tolerance		•	<p>• Network Tolerance is directly related to the current operating level of the video receiver's buffer. That is, the bigger the value, the greater the buffer usage will be.</p> <p>Additional latency is then introduced as a result, thus giving a better tolerance to packet distribution and network jitter. SMPTE ST 2022-7 Class A, wide source or software-based sources can then be received without errors.</p> <p>To optimize this parameter, start with the smallest Network Tolerance and increase it until video, metadata, and audio stream / media / redundancy statuses become GREEN.</p> <p>NOTE: If you want a specific IP buffer reception duration, such as 10ms, you need to make sure that the values you set for Link Offset - Link Latency = 10 ms.</p> <p>Network tolerance for encoders will add more packet buffering in a linear fashion.</p>  <p>For a decoder, a packet can be delayed by many microseconds because of the compression used. To avoid adding too much latency, with values near 1, buffering will increase slowly, but the more you increase the network tolerance, the amount of buffering increases in an exponential fashion.</p>  <p>NOTE: Metadata streams are automatically synchronized to the video. Incoming metadata streams should not be delayed by more than one frame with respect to the video to be properly synchronized. If the metadata stream is delayed by more than one frame, then it is going to be delayed by one frame. Use the Link Latency measurement to monitor this condition.</p> <p>Click  5 to reset the tolerance to the default value.</p>

Property	ENC	DEC	Description
Master	•	•	Set to enable a media receiver. This manages the Join/Release of both the primary and secondary streams. You must click Apply or press <Enter> to activate the change you have made to this setting. These settings can also be managed by external NMOS control. See NMOS Panel , on page 133.
Media	•	•	Shows the stream type. The background shows the current media status: Green: no error Red: error Grey: inactive
RTP Stream	•	•	Set to enable each stream receiver individually (primary and secondary). You must click Apply or press <Enter> to activate the change you have made to this setting. These settings can also be managed by external NMOS control. See NMOS Panel , on page 133.
Stream	•	•	Shows the primary (ETH1) and secondary (ETH2) stream receiver status: Green: no error Red: error Grey: inactive  indicates that the same IP stream has been joined multiple times through the same ETH port.
IGMPv3 Source	•	•	Set the source from which to receive multicast streams. With this protocol, the card deals with a switch to subscribe to one or many streams that are coming from different sources. Both iGMPv3 and iGMPv2 protocols are supported. Set this to 0.0.0.0 if iGMP source is not used. The source range is 0.0.0.0 to 255.255.255.255. The default value is 0.0.0.0. These settings can also be managed by external NMOS control. See NMOS Panel , on page 133.  indicates that the same IP stream has been joined multiple times through the same ETH port.  indicates that you must click Apply or press <Enter> to activate the change you have made to this setting.
RX Stream Address	•	•	Set the IP address and UDP port number at which this card receives a specific stream. IP address 0.0.0.0 disables a receiver. The default UDP port values are: 10000 for all media receivers.
RX Stream Port	•	•	These settings can also be managed by external NMOS control. See NMOS Panel , on page 133.  indicates that you must click Apply or press <Enter> to activate the change you have made to this setting.
SDP File	•	•	Click to show the last SDP file received through NMOS IS-05 since the last bootup. This window does not refresh automatically; you need to close and re-open the window to see an update. If the card has never received an SDP file since last its last bootup, the window will be empty.

Property	ENC	DEC	Description
Link Latency	•	•	Shows the time it takes for a packet to come from the source to the receiver. This measurement represents the difference between incoming RTP timestamp and PTP time before the receiver's buffer.
Buffer level	•	•	Shows the amount of preloaded data stored in the receiver that is ready for use as a percentage of the total. The current buffer level in percentage shows how much of the internal buffering is used to receive the current stream.
Link Offset	•	•	Shows the resulting link latency after being read out from receiver's buffer. NOTE: The decoder aligns the audio and ANC streams to the video stream. This measurement is the difference between the packet RTP timestamp and the PTP time after the receiver's buffer and represents the total reception delay. Video, Metadata, and audio link offset depends on the selected Network Tolerance. Moreover, Audio link offset can also depend on the syntonized mode.
Redundancy / Error	•	•	Shows the number of packets in error that will required SMPTE 2022-7 reconstruction for each Ethernet port.
Redundancy / Status	•	•	The background shows the current media status: Green: No error Red: Error Grey: Inactive
Reset counters Last Reset	•	•	Clear the number of errors shown above. When Reset is clicked, the current date and time is shown as a record of how long the corresponding error counter has been running since the last reset.
Apply Cancel	•	•	When active, this applies or rejects your current changes made in this tab. Pending changes are displayed with a  icon. Pressing <Enter> also applies your changes.

Senders Panel

For a JPEG-XS Encoder Channel:

This panel allows you to configure the destination media’s JPEG-XS compression level, and the SMPTE ST 2110-22 output stream’s IP addresses and port numbers for the processing channel (**Video 1**).

Statuses confirm that the RTP stream is successfully streaming.

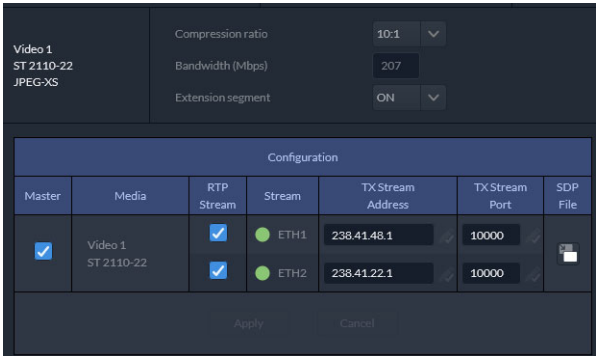

Figure 13-5: Senders Panel Encoder

For a JPEG-XS Decoder Channel:



This panel allows you to configure the support video, metadata, and audio channels, stream address, and port. The senders are SMPTE ST 2110-20 (**Video 1**), ST 2110-40 (**Meta 1**), and ST 2110-30/31 (**Audio 1**).

Statuses confirm that the RTP stream is successfully streaming.



Figure 13-6: Senders Panel Decoder

Property	ENC	DEC	Description
Video 1 ST 2110-22 JPEG-XS	•		<p>When this channel is encoding a JPEG-XS video stream only:</p> <p>Compression ratio: Sets the JPEG-XS video compression ratio of the encoder. Compression ratio is the video stream bit rate reduction due to compression of the input video stream versus the output video stream.</p> <p>Bandwidth (Mbps): Shows JPEG-XS video stream output bandwidth to be used with the selected compression ratio and current video format settings.</p> <p>Extension segment: Set to ON to insert an extension segment into the JPEG-XS stream with the following string: <i>GRASS VALLEY Copyright-Powered by IntoPIX.</i></p>
Audio 1 ST 2110-30/31 Type Profile		•	<p>When this channel is decoding a JPEG-XS video stream only:</p> <p>Type: Use the pull-down to set the audio stream's type for streams Audio 1.</p> <ul style="list-style-type: none"> • Type SMPTE ST 2110-30: for PCM linear audio (AES67 compatible) • Type SMPTE ST 2110-31: for transparent transport of non-linear audio and data formats. Provides bit-transparent AES3 over IP. <p>Profile: Use the pull-down to set audio profile for streams Audio 1. Audio senders support Level C as per SMPTE 2110-30/31: 48kHz stream from 1 to 8 channels (1 to 4 for SMPTE 2110-31) at packet times of 1ms and 1 to 16 channels at packet time of 125us.</p> <p>These settings can also be managed by external NMOS control. See NMOS Panel, on page 297.</p>
Master	•	•	<p>Set to enable a media sender. This manages both the primary and secondary streams.</p> <p>You must click Apply or press <Enter> to activate the change you have made to this setting.</p> <p>This can also be managed by external NMOS control. See NMOS Panel, on page 297.</p>
Media	•	•	Shows the stream type.
RTP Stream	•	•	<p>Set to enable a media stream sender for primary and secondary.</p> <p>You must click Apply or press <Enter> to activate the change you have made to this setting.</p> <p>This can also be managed by external NMOS control. See NMOS Panel, on page 297.</p>
Stream	•	•	<p>Shows the primary (ETH1) and secondary (ETH2) streaming status:</p> <p>Green: streaming</p> <p>Red: not streaming</p> <p>Grey: not active</p> <p>This can also be managed by external NMOS control. See NMOS Panel, on page 297.</p>

Property	ENC	DEC	Description
TX Stream Address	•	•	Set the IP address and UDP port number of the outgoing stream. IP address 0.0.0.0 disables a sender. The default UDP port values are 10000.
TX Stream Port	•	•	Address & UDP port can also be managed by external NMOS control. See NMOS Panel , on page 297.  indicates that you must click Apply or press <Enter> to activate the change you have made to this setting.
SDP File	•	•	Click to show the last SDP file transmitted through NMOS since the last bootup. This window does not refresh automatically; you need to close and re-open the window to see an update.
Apply Cancel	•	•	When active, this applies or rejects your current changes made in this tab. Pending changes are displayed with a  icon. Pressing <Enter> also applies your changes.

Video Panel

For a JPEG-XS Decoder Channel:

The video output is automatically aligned to PTP using a frame buffer. The output source is timestamped as a new source. When enabling minimum delay, the output is not aligned to PTP; only network tolerance will affect processing delay. The processing delay will vary based on the video format and the compression ratio.

For each processing channel, you can adjust the timing relative to the reference. Use the slider or type a value into the data box on the left of the slider. Metadata and audio streams will match the video delay set below.

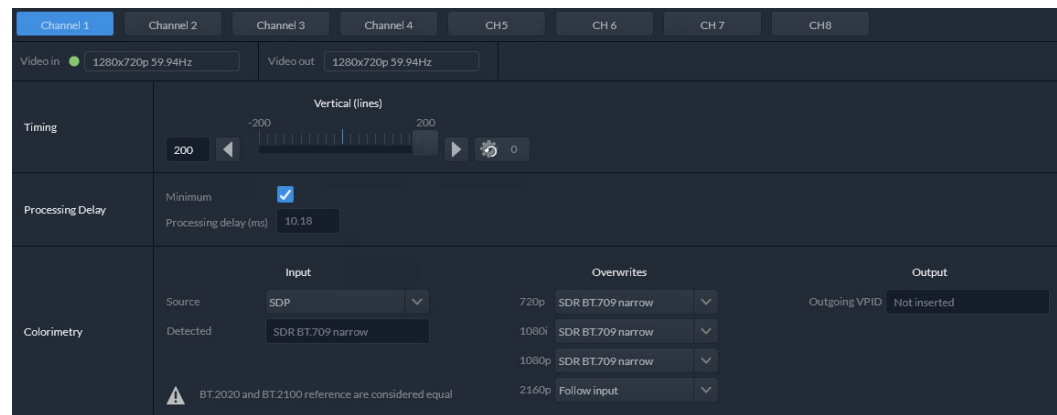

Figure 13-7: Video Panel Decoder

Processing delay will be affected by compression ratio and network tolerance. However, when minimum delay is OFF (Output is aligned to PTP) processing delay will also change based on incoming timing and output timing settings. Here is a guide for the processing delay with network tolerance of 5 and compression ratio 10:1, in minimum delay mode.

Format	ms
2160p59	0.9

Format	ms
1080p59	2.4
1080i59	4.8
720p59	5.4
2160p50	1
1080p50	2.9
1080i50	5.7
720p50	6.4

For a JPEG-XS Encoder Channel:

For the encoder, the processing delay is always at minimum delay. The output is not timestamped as a new source. This is done so that decoder will be able to compensate for the encoding processing delay.

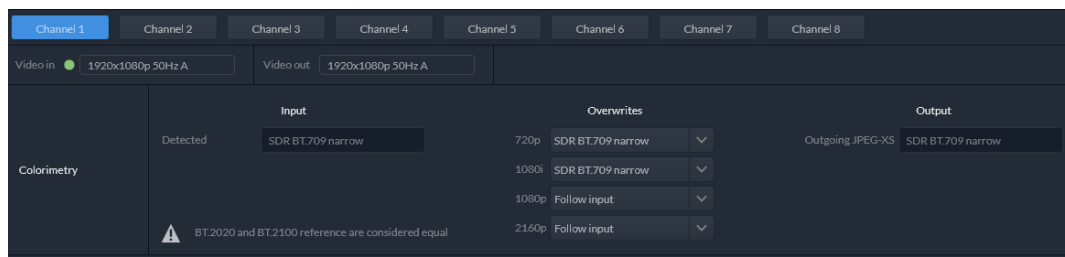

Figure 13-8: Video Panel Encoder

Processing delay will increase while increasing network tolerance. Here a guide for the processing delay with network tolerance of 5.

Format	ms
2160p59	1.2
1080p59	4.5
1080i59	9
720p59	10.1
2160p50	1.4
1080p50	5.4
1080i50	10.8
720p50	12.1

Property	ENC	DEC	Description
Timing Vertical Lines		•	Vertical adjustment slider setting applies to all output formats. Range: 200 to +200

Property	ENC	DEC	Description
Processing Delay - Minimum		•	Set to minimize processing delay. Video output will not be aligned to PTP. Processing delay will still be affected by setting of the Tolerance parameter. See the Tolerance parameter in Receivers Panel , on page 278. Audio and metadata are still aligned to the video.
Processing Delay - Processing delay		•	Shows the Processing Delay in microseconds so you can manage the processing delay on your system. See below.
Colorimetry		•	<p>Shows colorimetry information from the SDP file or from the JPEG-XS compressed stream and allows the colorimetry to be overwritten.</p> <p>Input / Source: Set the colorimetry source for the decoded JPEG-XS stream:</p> <ul style="list-style-type: none"> • JPEG-XS: Use the colorimetry information that was encoded in the received JPEG-XS video stream. • SDP File: Use the colorimetry from an SDP file (from an NMOS join). • Auto: Selects the colorimetry from the JPEG-XS stream when available and then as a second choice, the SDP file. <p>Input / Detected: Shows the detected Transfer Characteristic, Colorimetry, and Bit depth (Range) information.</p> <p>Overwrites: For each video format (720p, 1080i, 1080p, 2160p), optionally:</p> <ul style="list-style-type: none"> • Set the incoming video Payload ID should it be absent. • Override the incoming video Payload ID should it be incorrect. <p>Set one of the following Video Payload ID (Transfer Characteristic, Colorimetry, and Bit depth) processing options that can be used to overwrite this input parameter:</p> <ul style="list-style-type: none"> • Follow input: Follow the SDP file detected at the input. • SDR BT.709 narrow • SDR BT.2020 narrow • HLG BT.2020 narrow • HLG BT.2020 full • PQ BT.709 narrow • PQ BT.2020 narrow • PQ BT.2020 full <p>Default:</p> <ul style="list-style-type: none"> • Value in overwrite mode for 720p and 1080i is always SDR BT.709 narrow. • Value in overwrite mode for 1080p and 2160p is Follow input. <p>Output: Shows the current color information inserted into the SDP file and into the SDI VPID.</p>

Property	ENC	DEC	Description
Colorimetry	•		<p>Shows colorimetry information from the SDP file and allows the colorimetry to be overwritten.</p> <p>Input / Detected: Shows the detected Transfer Characteristic, Colorimetry, and Bit depth (Range) information contained within the SDP file (from an NMOS join).</p> <p>Overwrites: For each video format (720p, 1080i, 1080p, 2160p), optionally:</p> <ul style="list-style-type: none"> • Set the incoming video Payload ID should it be absent. • Override the incoming video Payload ID should it be incorrect. <p>Set one of the following Video Payload ID (Transfer Characteristic, Colorimetry, and Bit depth) processing options that can be used to overwrite this input parameter:</p> <ul style="list-style-type: none"> • Follow input: Follow the SDP file detected at the input. • SDR BT.709 narrow • SDR BT.2020 narrow • HLG BT.2020 narrow • HLG BT.2020 full • PQ BT.709 narrow • PQ BT.2020 narrow • PQ BT.2020 full <p>Default:</p> <ul style="list-style-type: none"> • Value in overwrite mode for 720p and 1080i is always SDR BT.709 narrow. • Value in overwrite mode for 1080p and 2160p is Follow input. <p>Output: Shows the current colorimetry being written to the SDP file and transmitted in the JPEG-XS compressed video stream. See also SDP colorimetry profile entry in Advanced. See Advanced Panel, on page 290.</p>

Audio Panel

For a JPEG-XS Decoder Channel:

For each processing channel, audio probing is shown.

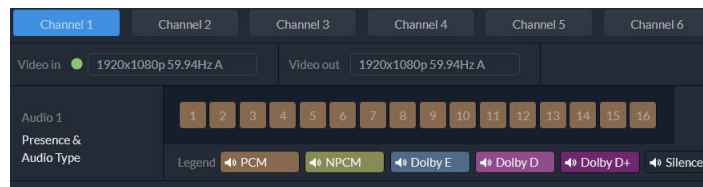
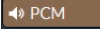

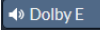
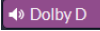
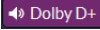
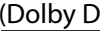

Figure 13-9: Audio Panel

For a JPEG-XS Encoder Channel:

This panel is not applicable.

Property	ENC	DEC	Description
Presence & Audio Type		<ul style="list-style-type: none"> Shows Audio 1 detection for embedded audio: <ul style="list-style-type: none">  PCM Signal is present and detected audio type is PCM  NPCM Signal is present and detected audio type is NPCM  Dolby E Signal is present and detected audio type is Dolby E  Dolby D Signal is present and detected audio type is Dolby Digital (Dolby D)  Dolby D+ Signal is present and detected audio type is Dolby Digital plus (Dolby D+)  Silence Signal not present because a silence of -60 dBFS or less was detected for over 3 seconds 	

Test Panel

For a JPEG-XS Decoder Channel:

For each processing channel, you can enable test pattern and select the type of test pattern to be used.

For a JPEG-XS Encoder Channel:

For each processing channel, you can enable test pattern and select the type of test pattern to be used.

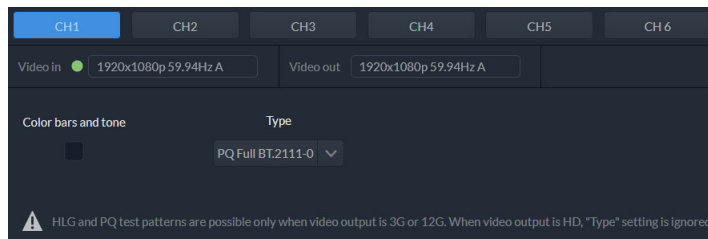

Figure 13-10: Test Panel

Property	Description
Color bars and tone	<p>Enables test signals at the card's output:</p> <ul style="list-style-type: none"> Video: Generate a video test pattern. On HD Video outputs, this will generate a 75% color bar with 75% white. On 1080p & 2160p Video outputs, test pattern will follow the format setting. Audio: Generate a 1 KHz sine wave at -18dBFS on all audio channel outputs: Continuous tone on right channel; pulsed tone on left channel of every pair (250 ms pulse every 3 seconds). Audio tones enabled on all 16 embedded audio channels and on all streamed audio channels. Metadata: blank

Property	Description
Type	Set video test pattern format for 1080p & 2160p Video outputs: <ul style="list-style-type: none"> • SDR BT.709 (75%): 75% Color bar with 75% white • HLG BT.2110-0: Test pattern HLG narrow range as per ITU-R BT.2111-0 • PQ Narrow BT.2111-0: Test pattern PQ narrow range as per ITU-R BT.2111-0 • PQ Full BT 2111-0: Test pattern PQ full range as per ITU-R BT.2110-0

Status

When Test mode is activated on a channel, the status icon display for that channel will show the Color Bars & Tone icon.



See [Section 1: Status Dashboard](#), on page 269.

Advanced Panel

The **Advanced** panel allows you to configure the outgoing payload type and DSCP priority for SMPTE 2110-20 (**Video**), SMPTE 2110-40 (**Meta 1**) and SMPTE 2110-30/31 (**Audio 1**). These settings apply to all channels.

Senders Advanced Configuration	Format	DSCP	Payload Type
	ST 2110-20	0	97
	ST 2110-22	0	112
	ST 2110-30	34	96
	ST 2110-31	34	101
	ST 2110-40	0	100
Colorimetry	SDP colorimetry profile entry		
	BT.2020	<input checked="" type="checkbox"/>	
	BT.2100	<input type="checkbox"/>	

Property	Description
DSCP	Sets the quality of service priority on the network for the outgoing video, metadata, and audio streams. The range is 0 to 63. The default values are: <ul style="list-style-type: none"> • 0 for SMPTE 2110-20 (Video) • 0 for SMPTE 2110-22 (Video) • 0 for SMPTE 2110-40 (Metadata) • 34 for SMPTE 2110-30 / 31 (audio)

Property	Description
Payload Type	<p>Sets the RTP Payload ID value of outgoing video, metadata and audio streams. Possible range: 0 to 128 The default value are:</p> <ul style="list-style-type: none"> • 97 for SMPTE 2110-20 (Video) • 112 for SMPTE 2110-22 (Video) • 100 for SMPTE 2110-40 (Metadata) • 96 for SMPTE 2110-30 (audio) • 101 for SMPTE 2110-31 (audio)
SDP colorimetry profile entry	<p>Set your preference for which terminology the card will use for the <i>colorimetry</i> attribute in the outgoing SDP files; either BT.2020 or BT.2100 terminology. This setting is common to all Senders. You can only overwrite the selected value when the output colorimetry is already BT.2020 or BT.2100.</p>

Interfaces Panel

The Interfaces panel allows you to configure the network settings for media and control Ethernet ports. ETH1 and ETH2 are media ports and ETH3 and FRM are control (management) ports.

- Media ports manage PTP, video, metadata, and audio streams, as well as NMOS IS-04 and IS-05 also.
- Control ports manage card upgrade as well as NMOS IS-04 and IS-05 also.

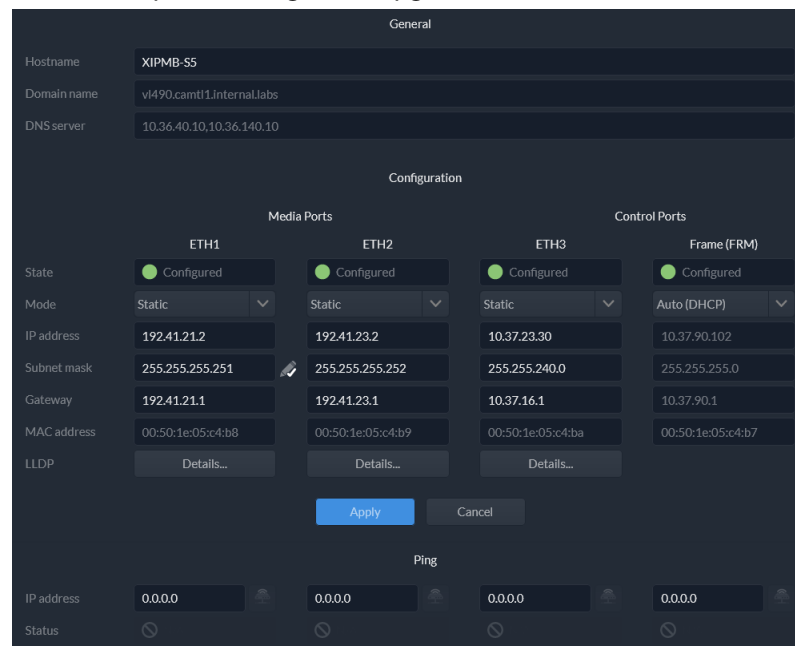



Figure 13-11: Interfaces Panel

Property	Description
Hostname	Set a unique network identification label by which this device will be known. Only alphanumeric characters and the hyphen are permitted.
Domain Name	Shows the name of the domain(s) the card is part of. At least one interface must be configured with DHCP in order to be able to receive this information.
DNS Servers	Shows the addresses of the name resolution servers. At least one interface must be configured with DHCP in order to be able to receive this information.
Media Port ETH1 and ETH2	The media ports support PTP, video, metadata, and audio streams and can be used for NMOS IS-04/IS-05 (see NMOS Panel , on page 297).
Control Port ETH3 Control Port Frame (FRM)	<p>The FRM port is a bridged port through the Densité frame controller. The physical frame controller's Ethernet port must be connected to the network for this interface to work. See Connections and Cabling, on page 63. Note: The FRM port address must not contain any of the frame controller's IP addresses.</p> <p>Control ports can be used for firmware upgrades:</p> <ul style="list-style-type: none"> • If the card is installed in a Densité 3+FR1 or Densité 3+FR4 frame with a CPU-ETH3 Basic controller, the ETH3 port must be used. Note: Before upgrading through the ETH3 port, you will need to configure ETH3 through the frame's local menu or install the iControl bundle for the current firmware version in order to configure ETH3. Once ETH3 has been configured, you will be able to upgrade/downgrade the card and its iControl bundle. • If the card is installed in a Densité 3+FR4 frame with a CPU-ETH3 Standard or Advanced controller, the firmware upgrade is performed using the frame controller's Ethernet port (FRM). <p>Control ports can also be used for NMOS IS-04 and IS-05. If both control ports are enabled and in the same subnet as the NMOS registry, the FRM port will be used.</p>
Mode	<p>Set the mode to assign an IP address to an Ethernet port.</p> <p>Off: Ethernet port disabled, it will not be used.</p> <p>Auto (DHCP): Ethernet port enabled with automatic configuration using a network's DHCP server.</p> <p>Static: Ethernet port enabled with static user specified configuration (IP Address, Subnet Mask, and Gateway).</p>
IP Address	When Mode is set to Static , set the card's IP address.
Subnet Mask	When Mode is set to Static , set the subnet mask for your network.
Gateway	When Mode is set to Static , set the network switch's IP address.
MAC address	Shows the Ethernet port's MAC Address.
LLDP	Shows the Link Layer Discovery Protocol (LLDP) TLV values. LLDP is used to advertise the identity, capabilities, and neighbors on a LAN. Click Details for any one Ethernet port to view the LLDP TLV values. See Network ETH LLDP Properties , on page 122.
Ping / IP Address Ping / Status	Test the IP connectivity to a device (on the same network) from any one Ethernet port for troubleshooting purposes. Enter the device's IP address and click  . In Status , a message shows the ping's IP connectivity status.

Property	Description
Apply Cancel	When active, this applies or rejects your current changes made in this tab. Pending changes are displayed in red. Pressing <Enter> also applies your changes.

FEC Panel

The FEC panel allows you to configure the media network's error correction scheme for **ETH 1** and **ETH 2**.

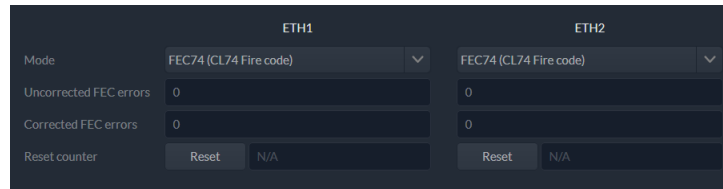

Figure 13-12: *FEC Panel*

Property	Description
Mode	The error correction mode: <ul style="list-style-type: none"> • Off: No error correction is used. • FEC74: Applies IEEE 802.3 Clause 74 Fire Code Forward Error Correction. • FEC108: Applies IEEE 802.3 Clause 108 Reed Solomon Forward Error Correction. Corresponding equipment sending or receiving these media streams must also be configured with the same error correction method. Otherwise the link will fail.
Uncorrected FEC Error Corrected FEC Error	The current number of detected errors at the physical layer. <ul style="list-style-type: none"> • Corrected errors are errors that the FEC algorithm was able to remove. • Uncorrected errors are errors that the FEC algorithm was unable to remove as the bit stream is too damaged. NOTE: The error counters only work when the Mode is set to FEC108 or FEC74.
Reset Counter	Clear the number of errors shown above. When Reset is clicked, the current date and time is shown as a record of how long the corresponding error counter has been running since the last reset.

SFP Panel

The SFP panel shows the media ports' SFP cartridge status.

	ETH1	ETH2
SFP+ module	Present	Present
Type	Fiber	Fiber
Speed	25000	25000
Vendor		
Part number		
Serial number		
Date code	20190606	200403
Revision	1A	1A
Wavelength (nm)	850	850
TX power (dBm)	0.7	-0.9
RX power (dBm)	-2.9	-1.3
Temperature (C)	35	37
Vcc (V)	3.3	3.3
TX bias (mA)	7	6.9

Figure 13-13: SFP Panel

Property	Description
SFP+ Module	The current status of the SFP+ module. Green: SFP module detected Grey: SFP mode not detected
Type	The connection media type.
Speed	The connection speed
Vendor	Manufacturer's information about the SFP+ module.
Part Number	
Serial Number	
Datacode	
Revision	
Wavelength	
TX Power	
RX Power	
Temperature	
Vcc	
TX Bias	

Statistics Panel

The Statistics panel shows the data transmission and reception statistics for the media ports. This information can be used to see the level of network utilization and to know if the level of media traffic is at or near the rated network bandwidth. A saturated network will result in packet loss at the receiver.

	ETH1		ETH2	
	RX	TX	RX	TX
Packets	975,926,230	1,046,335,810	976,510,032	1,048,330,383
Bandwidth (Mbps)	3,982	20,723	3,982	20,723
Bandwidth peak (Mbps)	4,423	23,017	4,383	22,808
Reset counter	<input type="button" value="Reset"/>	N/A	<input type="button" value="Reset"/>	N/A

Figure 13-14: *Statistics Panel*

When Reset is clicked, the current date and time is shown as a record of how long the packet counters have been running.

PTP Panel

Multicast Precision Timing Protocol (described in IEEE Standard 1588) is used to distribute time across a packet network. The XIP-3901-JPEG-XS uses PTP as a system clock and for output alignment using a frame buffer.

It is used on both media ports (ETH1 and ETH2) for BMCA redundancy. This supports Best Master Clock Algorithm (BMCA) as per IEEE-1588-2008. The XIP-3901-UDC-IF supports:

- SMPTE 2059-2 profile; locks the inputs and outputs on PTP
- AES-67 profiles
- Automatic one-step and two-step synchronization mode
- End-to-End Delay mechanism.
- Multicast PTP only

Video frame synchronization is not supported.

PTP Configuration		PTP Status		PTP Info	
Domain number	127	ETH1	Slave	Interface in use	ETH 1
Announce Interval (sec)	1	ETH2	Listening	Grand master clock ID	08:00:11:ff:fe:22:04:00
Announce receipt timeout count	3	PTP Locked	<input checked="" type="checkbox"/>	Parent clock ID	00:be:75:ff:fe:8e:8e:8f
DSCP	46			UTC offset (sec)	37
<input type="button" value="Apply"/>	<input type="button" value="Cancel"/>			Time source	GPS
				Sync mode	Two step
				Steps removed	4
				Priority 1	1
				Clock class	6
				Clock accuracy	< 100 ns
				Clock variance	15652
				Priority 2	1

Figure 13-15: *PTP Panel*

Property	Description
Domain Number	Specify the PTP Domain Number the card is to use to synchronize its clock. A domain is an interacting set of clocks that synchronize to one another using PTP. Clocks are assigned to a domain by virtue of the contents of the Subdomain name or the domain Number (IEEE 1588-2008) fields in PTP messages they receive or generate. The range is 0 to 127. The default value is 127.
Announce Interval	Specify the Announce message interval used by the parent clock (Boundary clock). Announce Interval range is: 0.125, 0.250, 0.500, 1, 2, 4, 8, 16 seconds. The default value is 0.125 second.
Announce Receipt Timeout Count	Specify the Announce Receipt Timeout used by the parent Boundary clock. The Announce Receipt Timeout range is 2 to 10 seconds. The default value is 3 seconds.
DSCP	Sets the quality of service priority for outgoing PTP packets. The range is 0 to 63. The default value is 46.
PTP Status ETH1 & ETH2	Shows the status of the ETH interfaces. The possible values are: Faulty: The protocol's fault state. Listening: The port is waiting for the announceReceiptTimeout to expire or to receive an Announce message from a master. Uncalibrated: One or more master ports have been detected in the domain. Slave: The port is synchronized to the selected master port.
PTP Locked	Shows the card's current overall PTP lock status to the network's Grandmaster clock. Green: The card has successfully locked to the network's PTP Grandmaster clock. Red: The card is not locked to the network's PTP Grandmaster clock.
Interface In Use	Shows the interface that is currently receiving PTP (ETH1, ETH2).
Grand Master Clock ID	Shows the Grand Master's clock ID (for example, Tektronix).
Parent Master Clock ID	Shows the Boundary clock's ID (Switch ID).
UTC Offset (sec)	Shows the current time offset between UTC and PTP. This value can change. The possible range is -32768 to 32767.
Time Source	Shows the source of time used by the grandmaster clock. The possible values are Atomic Clock, GPS, Terrestrial Radio, PTP, NTP, Hand Set, Other, Internal Oscillator.
Sync mode	Shows the Sync Mode from the Grand Master. A boundary clock cannot have a different setting. The possible values are One Step, Two Step.
Steps removed	Shows how many hops the card is from the Grandmaster. This is used by the Best Master Clock Algorithm (BCMA). The possible values are 0 to 65535.
Priority 1	Shows the first priority. This is used in the execution of the Best Master Clock Algorithm (BCMA). The Priority (1 or 2) with the lowest value will be used as the clock reference. The possible values are 0 to 255.

Property	Description
Clock Class	Shows the clockClass attribute of an ordinary or boundary clock. This denotes the traceability of the time or frequency distributed by the grandmaster clock. The possible values are 0 to 255. For example, 6 = GPS, 99 = free run.
Clock Accuracy	Shows the clock's accuracy range with respect to UTC.
Clock Variance	Shows the calculated jitter and wander of the clock's oscillator over a Sync message interval.
Priority 2	Shows the second priority. This is used in the execution of the Best Master Clock Algorithm (BCMA). The possible values are 0 to 255.

NMOS Panel

The XIP-3901-JPEG-XS supports Networked Media Open Specifications (NMOS) AMWA IS-04 for device discovery and registration and IS-05 for connection management. Furthermore, it supports AMWA BCP-002 recommendations for Grouping NMOS Resources.

The XIP-3901-JPEG-XS relies on an external NMOS registry that is used to register NMOS devices. You must point the XIP-3901-JPEG-XS to this external NMOS registry.

PREREQUISITE: A working NMOS registry service must be available on the network.

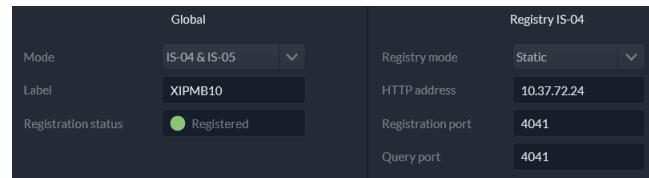

Figure 13-16: NMOS Panel

Property	Description
Mode	Set the NMOS mode: IS-04: enable the Networked Media Open Specifications (NMOS) IS-04 v1.2 or higher for device discovery and registration. All senders will publish and update SDP file, but receivers can't be updated. IS-04 & IS-05: enable the NMOS IS-04 for device discovery and registration and IS-05 for connection management. All senders will publish and update an SDP File and receivers will accept routing request and process the received SDP file. OFF: disable NMOS. This eliminates the RED status when NMOS IS-04 is not used. This is the default.
Label	Set the identifier by which this XIP-3901-JPEG-XS card will be known in the NMOS registry, and by extension, to other NMOS devices using this NMOS registry.
Registration Status	Shows if the card has successfully registered itself in the NMOS registry. Green: the card has successfully registered itself with the NMOS registry. Red: the card is not yet registered with the NMOS registry. Grey: NMOS is disabled (Mode is OFF).

Property	Description
Registry IS-04, Registry Mode	<p>Set the IS-04, Registry Mode:</p> <p>Auto: automatic discovery of the NMOS registry using DNS Service Discovery (DNS-SD), as described in AMWA IS-04 NMOS Discovery and Registration Specification v1.2.</p> <p>Static: manually specified NMOS registry values for address, registration port and query port. In this mode, by specifying a registry address in the same subnet as one of the interfaces, the interface will be used. However, when specifying an address in a different subnet, the first available interface will be used in the following order: FRM, ETH3, ETH1, and then ETH2.</p> <p>The default Registry Port value is 3210. The default Query Port value is 3211.</p>
HTTP Address	Set the NMOS registry's IP Address when the Registry IS-04, Registry Mode is Static .
Registration Port	Set the NMOS registry's registration port number when the Registry IS-04, Registry Mode is Static .
Query Port	Set the NMOS registry's query port number when the Registry IS-04, Registry Mode is Static .

Info Panel

When this card is used in a control system such as GV Orbit, certain information about the card can be made available to control system. You can enter labels and comments that will make this card easy to identify in a complex setup. This information is entered into data boxes in the **Friendly Names** part of the panel.

Card Info	Device type	XIP-3901-JPEG-XS
	Description	Multichannel JPEG-XS Encode / Decode ST-2110 Application
	Manufacturer	Grass Valley
	Vendor	Grass Valley
	Rear Type	XIP-3901-3+DRP
	Firmware version	0.9.0.198
	PCB version	0.1.1
	Serial number	306501-131391027
	REST API	http://10.37.23.30/apl/
	REST API documentation	http://10.37.23.30/apl/doc
Friendly Names	Application & Channels	Name
	XIP-3901-JPEG-XS	8x DEC
	Channel 1: HD DEC 1	CH1
	Channel 2: HD DEC 2	CH2
	Channel 3: HD DEC 3	CH3
	Channel 4: HD DEC 4	CH4
	Channel 5: HD DEC 5	CH5
	Channel 6: HD DEC 6	CH 6
	Channel 7: HD DEC 7	CH 7
Channel 8: HD DEC 8	CH8	

Figure 13-17: Info Panel

Property	Description
Device type	Shows the card's current application.
Description	Shows a short description of the card.
Manufacturer Vendor	Shows information about the card's manufacturer.
Rear Type	The rear panel model number paired with the card.
Firmware version	The card's current firmware version.
PCB version	The card's hardware version.
Serial number	The card's serial number.
REST API	Click to see the Card's REST API. With this interface, you can create your own interface for this card. This requires a web development effort to achieve this.
REST API documentation	Click to see the Card's REST API documentation, for information about the card's REST API interface.
Friendly Names - XIP-3901-JPEG-XS	Set the name by which this card will be easily recognized by a person working with this card in a control system such as GV Orbit. This also changes the name for this card in the title at the top of the web page.

Property	Description
Friendly Names - Channel 1: to Channel <i>n</i>	Set the name by which channels 1 to <i>n</i> will be easily recognized by a person working with this card in a control system such as GV Orbit. This also changes the name for this channel in the Status Icons. See Section 1: Status Dashboard , on page 269.

Operation Mode

See [Setting the Card's Operation Mode](#), on page 275.

Applications Panel

This panel is used to activate or switch between applications. It shows all the applications on the platform, their respective versions, whether their license keys have been activated, and which one is currently **In Use**.

Application	Version	Activation	License	In Use
XIP-3901-UC	2.0.0.389	Activate	●	●
XIP-3901-DC	2.1.0.276	Activate	●	●
XIP-3901-FS	2.0.0.130	Activate	●	●
XIP-3901-UDC-IP	1.3.1.445	Activate	●	●
XIP-3901-UDC-IF	3.1.0.79	Activate	●	●
XIP-3901-JPEG-XS	1.0.0.219	Activate	●	✓

XIP-3901-XX is a software key that identifies applications on the XIP-3901 platform.
To activate an application, please contact Grass Valley customer service at +1-514-333-1772, and specify the software key and the card's serial number 306501-131391027.

Figure 13-18: Applications Panel

Until an application has been activated, the SDI / IP outputs will be inactive. Although the settings can be adjusted for an application, the effects will only become apparent when the license key has been activated.

Activating an Application

- 1 Call Grass Valley at the number displayed at the bottom of the panel and provide your serial number to receive a license key.
- 2 In the License column for the application, enter the license key and click **Activate**.

Application	Version	Activation	License	In Use
XIP-3901-UC	2.0.0.389	Activate	●	●
XIP-3901-DC	2.1.0.276	Activate	●	●
XIP-3901-FS	2.0.0.130	Activate	●	●
XIP-3901-UDC-IP	1.3.1.445	Activate	●	●
XIP-3901-UDC-IF	3.1.0.79	Activate	●	●
XIP-3901-JPEG-XS	1.0.0.207	Activate	license key <input type="button" value="Activate"/>	●

XIP-3901-XX is a software key that identifies applications on the XIP-3901 platform.
To activate an application, please contact Grass Valley customer service at +1-514-333-1772, and specify the software key and the card's serial number 306501-131391027.

Figure 13-19: Applying a License Key to an installed Application

Once an application has been activated, it cannot be deactivated.

Switching to a Different Application

- 1 Select the **In Use** radio button for the application you want to change to.

Application	Version	Activation	License	In Use
XIP-3901-UC	2.0.0.389	Activate		<input type="radio"/>
XIP-3901-DC	2.1.0.276	Activate		<input type="radio"/>
XIP-3901-FS	2.0.0.130	Activate		<input type="radio"/>
XIP-3901-UDC-IP	1.3.1.445	Activate		<input checked="" type="radio"/>
XIP-3901-UDC-IF	3.1.0.79	Activate		<input type="radio"/>
XIP-3901-JPEG-XS	1.0.0.207	license key Activate		<input checked="" type="radio"/>

XIP-3901-XX is a software key that identifies applications on the XIP-3901 platform.
To activate an application, please contact Grass Valley customer service at +1-514-333-1772,
and specify the software key and the card's serial number 306501-131391027.

Figure 13-20: *Applications Panel*

- 2 In the Confirmation dialog box, click **OK**.

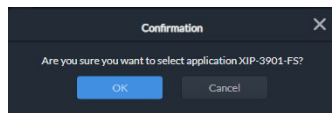

Figure 13-21: *Confirmation*

- 3 Wait several seconds for the application to reboot.

Alarm Configuration Panel

This panel is used to configure the alarm reporting of the XIP-3901 application. It has an expandable tree listing all the alarms reported by this XIP-3911 or XIP-3901 card.

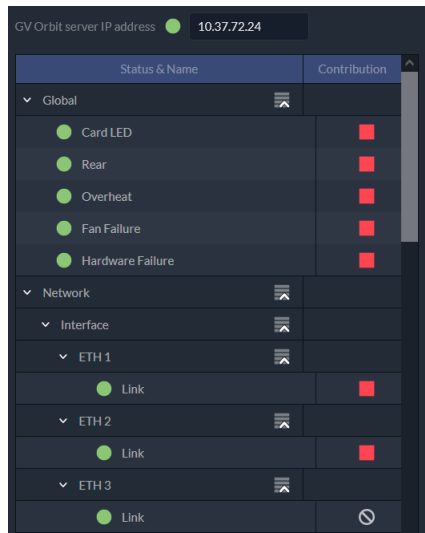
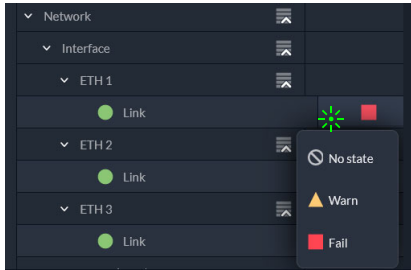

Figure 13-22: Alarm Configuration Panel

Property	Description
GV Orbit server IP address	<p>Alarms from the card can be sent to GV Orbit to be taken into account in its alarm list and alarm logging.</p> <p>When a GV Orbit server is present on your network, set the IP address of:</p> <ul style="list-style-type: none"> • The GV Orbit server's Management port. • The GV Orbit server's Virtual IP address when this is configured, such as in the case of a GV Orbit cluster, for example. <p>Furthermore, the GV Orbit Alarm API service must have its Enable Write Access property set to enabled.</p> <p>See the GV Orbit Admin Guide for more information about the configuration of:</p> <ul style="list-style-type: none"> • IP addresses for a GV Orbit server. • GV Orbit Alarm API service.
Status/Name	<p>This column contains an expandable tree listing all the alarms reported by this XIP-3901-JPEG-XS application.</p> <ul style="list-style-type: none"> • Each alarm name includes an icon that shows its current status.

Property	Description
Contribution	<p>Apart from the Global alarms, click a Contribution column item to set the severity level of each individual alarm to the alarm named in the column heading. This applies to the front card -edge LED and to the alarms reported to GV Orbit. See Front Card-edge Interface, on page 41.</p>  <p>Black icon: The alarm makes no contribution. Yellow icon: The alarm is of minor importance (warn). Red icon: The alarm is of critical importance (fail).</p>
Card Led	This shows the current status of the status LED located on the front card-edge. If at least one Critical or Fail alarm is triggered, the LED will change to red. If no Fail alarms are triggered and Warn alarms are occurring, the LED will change to yellow.
Rear	These are the card's master alarms.
Overheat	
Fan Failure	
Hardware Failure	
Network	
PTP	
NMOS	
<i>Receivers</i>	
Senders	
Inputs / Outputs	
Test	

Factory/Presets Panel

This panel provides access to three functions, which apply only to the current application.

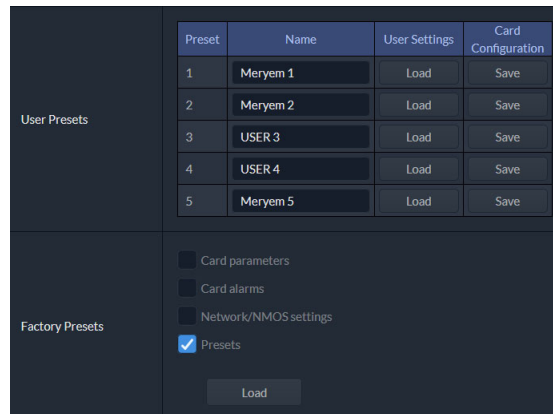
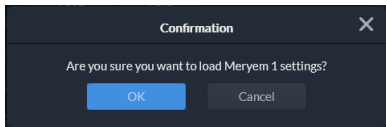
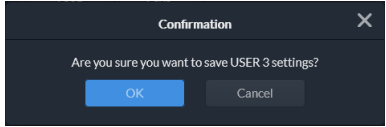

Figure 13-23: Factory/Presets Panel (Shown on XIP-3901-UC)

Property	Description
User Presets	<p>Preset: Each XIP-3901 application has memory registers that can hold up to five user-defined parameter settings.</p> <p>Name: Set a name or rename a preset by typing a new name in the preset Name field. (up to 16 characters)</p> <p>User Setting: Click Load to load the contents of the user preset into the XIP-3901 application. All parameter settings and values will be replaced by the contents of the selected user preset. However, this will not load the IP configuration of the card's Ethernet configuration.</p> <p>A confirmation box will pop up to allow you to proceed or cancel the load.</p>  <p>Figure 13-24: Load User Settings Confirmation Box</p> <p>Card Configuration: Click Save to store the current parameter settings and values from the XIP-3901 application in the selected user preset. The existing contents of the preset will be overwritten. A confirmation box will pop up to allow you to proceed or cancel the save.</p>  <p>Figure 13-25: Save Configuration Confirmation Box</p>

Property	Description
Factory Presets	<p>Click Load to restore the card to a factory default state when one or more checkboxes are selected to reset the following:</p> <p>Card parameters: Any configuration setting you have made are reset to their default settings.</p> <p>Card alarms: Alarm contribution settings are set to their default values.</p> <p>Network/NMOS settings: The card's IP interface configuration and NMOS settings are reset to their default values.</p> <p>Presets: The above User Preset are cleared and the preset labels are reset to their default values.</p>

Upgrade Panel

See [Card Upgrade](#), on page 263.

Technical Support Panel

Property	Description
Contact	If you have any questions or suggestions, contact Grass Valley Technical Support.
Reboot Card	Click to reboot the card
System Snapshot	<p>A system snapshot creates a compressed file that contains information that can be used by Grass Valley Technical Support for troubleshooting purposes. Proceed as follows:</p> <ol style="list-style-type: none"> 1 Click Generate. 2 Click Download snapshot when this appears. 3 Save the file to your PC's hard disk. 4 Send the file to Grass Valley Technical Support for analysis.

14

Configuring the XIP 3901-ASI v1.0 Application with its Web Interface

XIP-3901-UC, XIP-3901-DC, or XIP-3901-FS	XIP-3901-UDC-IP	XIP-3901-UDC-IF	XIP-3901-GB-IP	XIP-3901-JPEG XS	XIP-3901-ASI
					●

This section describes the control panels associated with the XIP-3901-ASI application and its use.

XIP-3901-ASI Panel Selection Tree

Click an entry in the panel selection tree to view the configuration panel. For more information about the panel selection tree, see also [Section 3: Panel Selection Tree](#), on page 271.

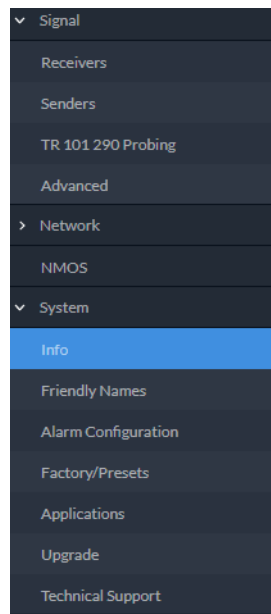

Figure 14-1: XIP-3901-ASI Panel Selection Tree

For more information about the configuration panels, see:

- [Receivers Panel](#), on page 308
- [Senders Panel](#), on page 310
- [TR 101 290 Probing Panel](#), on page 311

- [Advanced Panel](#), on page 313
- [Interfaces Panel](#), on page 313
- [FEC Panel](#), on page 316
- [SFP Panel](#), on page 317
- [Statistics Panel](#), on page 318
- [NMOS Panel](#), on page 318
- [Info Panel](#), on page 319
- [Friendly Names Panel](#), on page 320
- [Alarm Configuration Panel](#), on page 321
- [Factory/Presets Panel](#), on page 323
- [Applications Panel](#), on page 324
- [Upgrade Panel](#), on page 325
- [Technical Support Panel](#), on page 325

Receivers Panel

These signals are available at the rear panel connectors. See [Summary of Rear Panel Connections](#), on page 50.

This panel allows you to configure the expected source media’s stream address, port, and IGMPv3 source. The receiver’s standard is SMPTE ST 2022-2/3.

Stream Statuses confirm that the RTP stream has successfully joined.

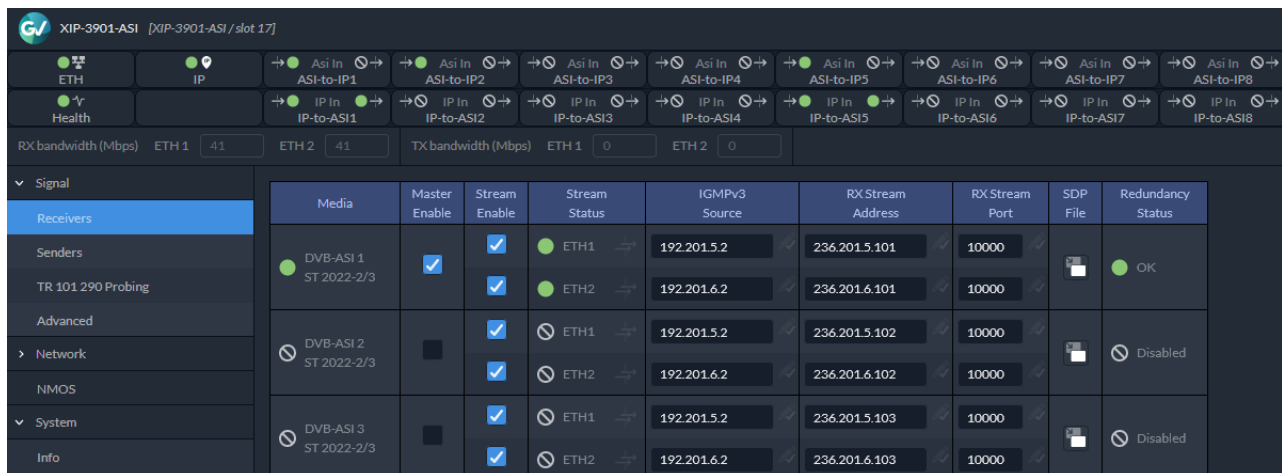







Figure 14-2: Receivers Panel

Property	Description
Media	Shows the stream type. The indicator shows the current media status: Green: no error Red: error Grey: inactive

Property	Description
Master Enable	<p>Set to enable a media receiver. This manages the Join/Release of both the primary and secondary streams.</p> <p>You must click Apply or press <Enter> to activate the change you have made to this setting.</p> <p>These settings can also be managed by external NMOS control. See NMOS Panel, on page 133.</p>
Stream Enable	<p>Set to enable each stream receiver individually (primary and secondary).</p> <p>You must click Apply or press <Enter> to activate the change you have made to this setting.</p> <p>These settings can also be managed by external NMOS control. See NMOS Panel, on page 133.</p>
Stream Status	<p>Shows the primary (ETH1) and secondary (ETH2) stream receiver status:</p> <p>Green: no error Red: error Grey: inactive</p> <p> indicates that the same IP stream has been joined multiple times through the same ETH port.</p>
IGMPv3 Source	<p>Set the source from which to receive multi-cast streams. With this protocol, the card deals with a switch to subscribe to one or many streams that are coming from different sources.</p> <p>Both iGMPv3 and iGMPv2 protocols are supported. Set this to 0.0.0.0 if iGMP source is not used. The source range is 0.0.0.0 to 255.255.255.255. The default value is 0.0.0.0.</p> <p>These settings can also be managed by external NMOS control. See NMOS Panel, on page 133.</p> <p> indicates that the same IP stream has been joined multiple times through the same ETH port.</p> <p> indicates that you must click Apply or press <Enter> to activate the change you have made to this setting.</p>
RX Stream Address	<p>Set the IP address and UDP port number at which this card receives a specific stream. IP address 0.0.0.0 disables a receiver. The default UDP port values are: 10000 for all media receivers.</p>
RX Stream Port	<p>These settings can also be managed by external NMOS control. See NMOS Panel, on page 133.</p> <p> indicates that you must click Apply or press <Enter> to activate the change you have made to this setting.</p>
SDP File	<p>Click to show the last SDP file received through NMOS IS-05 since the last boot-up. This window does not refresh automatically; you need to close and re-open the window to see an update. If the card has never received an SDP file since its last boot-up, the window will be empty.</p>
Redundancy Status	<p>The background shows the current media status:</p> <p>Green: No error Red: Error Grey: Inactive</p>

Property	Description
Apply	When active, this applies or rejects your current changes made in this tab.
Cancel	Pending changes are displayed with a  icon. Pressing <Enter> also applies your changes.

Senders Panel

For an ASI Channel:

This panel allows you to configure the destination media’s ASI compression level, and the SMPTE ST 2022-2/3 output stream’s IP addresses and port numbers for the processing channel.

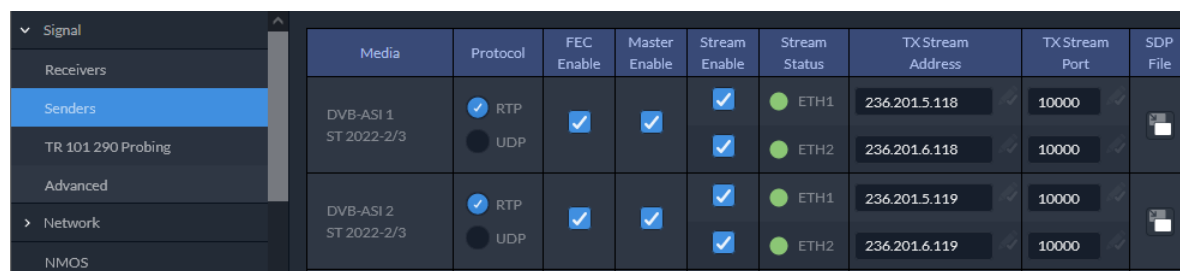



Figure 14-3: Senders Panel

Property	Description
Media	Shows the stream type.
Protocol	Set to enable each stream to either use the RTP or UDP protocol.
FEC Enable	Set to enable FEC (Forward Error Correction) for each stream.
Master Enable	Set to enable a media sender. This manages both the primary and secondary streams. You must click Apply or press <Enter> to activate the change you have made to this setting. This can also be managed by external NMOS control. See NMOS Panel , on page 318.
Stream Enable	Set to enable a media stream sender for primary and secondary. You must click Apply or press <Enter> to activate the change you have made to this setting. This can also be managed by external NMOS control. See NMOS Panel , on page 318.
Stream Status	Shows the primary (ETH1) and secondary (ETH2) streaming status: Green: streaming Red: not streaming Grey: not active This can also be managed by external NMOS control. See NMOS Panel , on page 318.

Property	Description
TX Stream Address	Set the IP address and UDP port number of the outgoing stream. IP address 0.0.0.0 disables a sender. The default UDP port values are 10000.
TX Stream Port	Address & UDP port can also be managed by external NMOS control. See NMOS Panel , on page 318.  indicates that you must click Apply or press <Enter> to activate the change you have made to this setting.
SDP File	Click to show the last SDP file transmitted through NMOS since the last boot-up. This window does not refresh automatically; you need to close and re-open the window to see an update.
Apply Cancel	When active, this applies or rejects your current changes made in this tab. Pending changes are displayed with a  icon. Pressing <Enter> also applies your changes.

TR 101 290 Probing Panel

The TR 101 290 Probing panel has two tabs to monitor ASI inputs and IP inputs of the XIP-3901-ASI application. Select a tab to view the status report of errors either for ASI Inputs or IP Inputs.

For ASI Inputs:

TR 101 290 Error Name		Enable	Channel 1 ASI-to-IP1	Channel 2 ASI-to-IP2	Channel 3 ASI-to-IP3	Channel 4 ASI-to-IP4	Channel 5 ASI-to-IP5	Channel 6 ASI-to-IP6	Channel 7 ASI-to-IP7	Channel 8 ASI-to-IP8
1.1 TS Sync Loss	<input checked="" type="checkbox"/>	 2	 0	 0	 0	 0	 0	 0	 0	 0
1.2 TS Sync Byte	<input checked="" type="checkbox"/>	 7	 0	 0	 0	 0	 0	 0	 0	 0
1.3 PAT	<input checked="" type="checkbox"/>	 0	 0	 0	 0	 0	 0	 0	 0	 0
1.4 Continuity Count	<input checked="" type="checkbox"/>	 208	 0	 0	 0	 0	 0	 0	 0	 0
1.5 PMT Table	<input checked="" type="checkbox"/>	 0	 0	 0	 0	 0	 0	 0	 0	 0
1.6 PID	<input checked="" type="checkbox"/>	 0	 0	 0	 0	 0	 0	 0	 0	 0
Reset counters										
Last Reset		01/01/1970, 12:15:25 pm								

Figure 14-4: TR 101 290 Probing Panel (ASI Inputs)

For IP Inputs:

ASI Inputs		IP Inputs							
TR 101 290 Error Name	Enable	Channel 1 IP-to-ASI1	Channel 2 IP-to-ASI2	Channel 3 IP-to-ASI3	Channel 4 IP-to-ASI4	Channel 5 IP-to-ASI5	Channel 6 IP-to-ASI6	Channel 7 IP-to-ASI7	Channel 8 IP-to-ASI8
1.1 TS Sync Loss	<input checked="" type="checkbox"/>	0	0	0	0	1	0	0	0
1.2 TS Sync Byte	<input checked="" type="checkbox"/>	0	0	0	0	2	0	0	0
1.3 PAT	<input checked="" type="checkbox"/>	0	0	0	0	1	0	0	0
1.4 Continuity Count	<input checked="" type="checkbox"/>	0	0	0	0	81	0	0	0
1.5 PMT Table	<input checked="" type="checkbox"/>	0	0	0	0	1	0	0	0
1.6 PID	<input checked="" type="checkbox"/>	0	0	0	0	0	0	0	0
Reset counters									
Last Reset		01/01/1970, 12:15:30 pm							

Figure 14-5: TR 101 290 Probing Panel (IP Inputs)

Property	Description
TR 101 290 Error Name	The name of each error parameter according to TR 101 290 probe tests.
Enable	Set to enable error reporting for the parameter in all channels.
Channel 1- 8 Channel name	Shows the number of error occurring for each parameter in real time and the streaming status of each channel: Green: streaming Red: not streaming Grey: not active Channel names can be customized with the Friendly Names parameters; see Friendly Names Panel , on page 320.
1.1 TS Sync Loss	The error parameter of transport stream sync loss for streaming channels. The loss of just 2 sync bytes indicates a loss of sync.
1.2 TS Sync Byte	The error parameter of transport stream sync byte for streaming channels. If the sync byte is not equal to 47 hexadecimals, then a sync byte error occurs.
1.3 PAT	The error parameter of PAT (Program Association Table).
1.4 Continuity Count	The error parameter of continuity count. This error occurs when any of the following faults happen — incorrect packet order, a packet occurs more than twice or a packet is lost.
1.5 PMT Table	The error parameter of PMT (Program Map Table).
1.6 PID	The error parameter of PID (Packet ID).

Property	Description
Reset counters Last reset	Clear the number of errors shown in the display. When Reset counters button is clicked, the current date and time is shown as a record of how long the corresponding error counter has been running since the last reset.

Advanced Panel

The **Advanced** panel allows you to configure the Bitrate Mode in your operation. This setting applies to all channels.

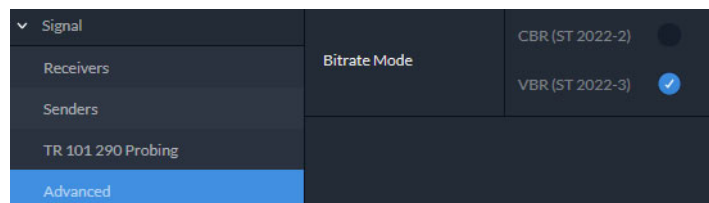

Figure 14-6: *Advanced Panel*

Property	Description
Bitrate Mode	Sets the bitrate mode on the network for video, metadata, and audio streams. Select one from these 2 options below: <ul style="list-style-type: none"> • Constant bitrate for CBR (ST 2022-2) • Variable bitrate for VBR (ST 2022-3)

Interfaces Panel

The Interfaces panel allows you to configure the network settings for media and control Ethernet ports. ETH1 and ETH2 are media ports and ETH3 and FRM are control (management) ports.

- Media ports manage PTP, video, metadata, and audio streams, as well as NMOS IS-04 and IS-05 also.

- Control ports manage card upgrade as well as NMOS IS-04 and IS-05 also.

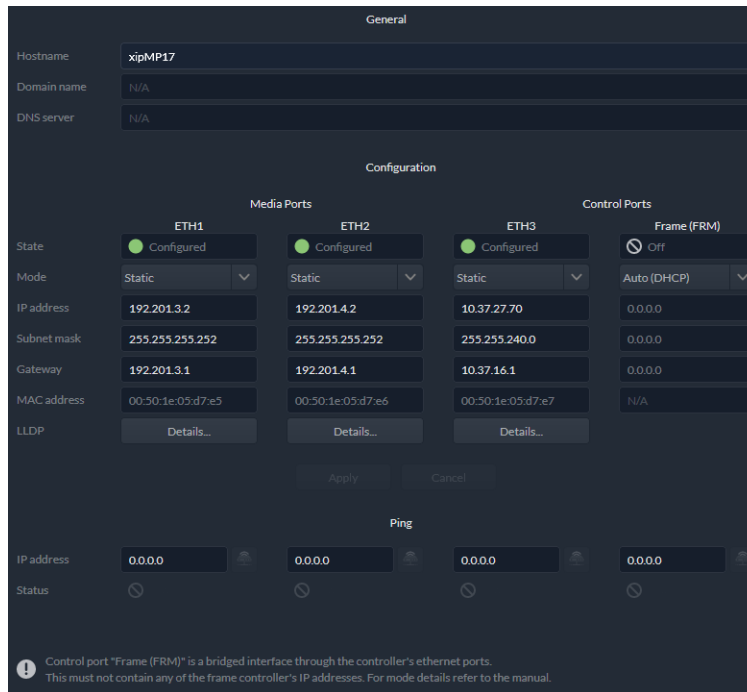



Figure 14-7: Interfaces Panel

Property	Description
Hostname	Set a unique network identification label by which this device will be known. Only alphanumeric characters and the hyphen are permitted.
Domain Name	Shows the name of the domain(s) the card is part of. At least one interface must be configured with DHCP in order to be able to receive this information.
DNS Servers	Shows the addresses of the name resolution servers. At least one interface must be configured with DHCP in order to be able to receive this information.
Media Port ETH1 and ETH2	The media ports support PTP, video, metadata, and audio streams and can be used for NMOS IS-04/IS-05 (see NMOS Panel , on page 318).

Property	Description
Control Port ETH3 Control Port Frame (FRM)	<p>The FRM port is a bridged port through the Densité frame controller. The physical frame controller's Ethernet port must be connected to the network for this interface to work. See Connections and Cabling, on page 63. Note: The FRM port address must not contain any of the frame controller's IP addresses.</p> <p>Control ports can be used for firmware upgrades:</p> <ul style="list-style-type: none"> • If the card is installed in a Densité 3+FR1 or Densité 3+FR4 frame with a CPU-ETH3 Basic controller, the ETH3 port must be used. Note: Before upgrading through the ETH3 port, you will need to configure ETH3 through the frame's local menu or install the iControl bundle for the current firmware version in order to configure ETH3. Once ETH3 has been configured, you will be able to upgrade/downgrade the card and its iControl bundle. • If the card is installed in a Densité 3+FR4 frame with a CPU-ETH3 Standard or Advanced controller, the firmware upgrade is performed using the frame controller's Ethernet port (FRM). <p>Control ports can also be used for NMOS IS-04 and IS-05. If both control ports are enabled and in the same subnet as the NMOS registry, the FRM port will be used.</p>
Mode	<p>Set the mode to assign an IP address to an Ethernet port.</p> <p>Off: Ethernet port disabled, it will not be used.</p> <p>Auto (DHCP): Ethernet port enabled with automatic configuration using a network's DHCP server.</p> <p>Static: Ethernet port enabled with static user specified configuration (IP Address, Subnet Mask, and Gateway).</p>
IP Address	When Mode is set to Static , set the card's IP address.
Subnet Mask	When Mode is set to Static , set the subnet mask for your network.
Gateway	When Mode is set to Static , set the network switch's IP address.
MAC address	Shows the Ethernet port's MAC Address.
LLDP	Shows the Link Layer Discovery Protocol (LLDP) TLV values. LLDP is used to advertise the identity, capabilities, and neighbors on a LAN. Click Details for any one Ethernet port to view the LLDP TLV values. See Network ETH LLDP Properties , on page 122.
Ping / IP Address Ping / Status	Test the IP connectivity to a device (on the same network) from any one Ethernet port for troubleshooting purposes. Enter the device's IP address and click  . In Status , a message shows the ping's IP connectivity status.
Apply Cancel	When active, this applies or rejects your current changes made in this tab. Pending changes are displayed in red. Pressing <Enter> also applies your changes.

FEC Panel

The FEC panel allows you to configure the media network’s error correction scheme for **ETH 1** and **ETH 2**.

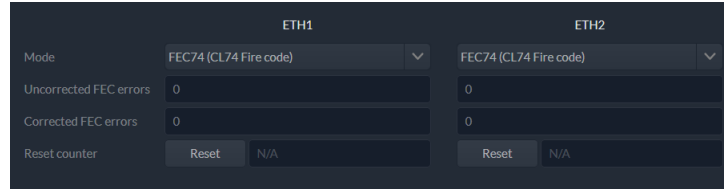

Figure 14-8: FEC Panel

Property	Description
Mode	The error correction mode: <ul style="list-style-type: none"> • Off: No error correction is used. • FEC74: Applies IEEE 802.3 Clause 74 Fire Code Forward Error Correction. • FEC108: Applies IEEE 802.3 Clause 108 Reed Solomon Forward Error Correction. Corresponding equipment sending or receiving these media streams must also be configured with the same error correction method. Otherwise the link will fail.
Uncorrected FEC Error Corrected FEC Error	The current number of detected errors at the physical layer. <ul style="list-style-type: none"> • Corrected errors are errors that the FEC algorithm was able to remove. • Uncorrected errors are errors that the FEC algorithm was unable to remove as the bit stream is too damaged. NOTE: The error counters only work when the Mode is set to FEC108 or FEC74.
Reset Counter	Clear the number of errors shown above. When Reset is clicked, the current date and time is shown as a record of how long the corresponding error counter has been running since the last reset.

SFP Panel

The SFP panel shows the media ports' SFP cartridge status.

	ETH1	ETH2
SFP+ module	● Present	● Present
Type	Fiber	Fiber
Speed	25000	25000
Vendor		
Part number		
Serial number		
Date code	20190606	200403
Revision	1A	1A
Wavelength (nm)	850	850
TX power (dBm)	● 0.7	● -0.9
RX power (dBm)	● -2.9	● -1.3
Temperature (C)	● 35	● 37
Vcc (V)	● 3.3	● 3.3
TX bias (mA)	● 7	● 6.9

Figure 14-9: SFP Panel

Property	Description
SFP+ Module	The current status of the SFP+ module. Green: SFP module detected Grey: SFP mode not detected
Type	The connection media type.
Speed	The connection speed
Vendor	Manufacturer's information about the SFP+ module.
Part Number	
Serial Number	
Datacode	
Revision	
Wavelength	These are values from the SFP's Diagnostic Monitoring Interface (DMI). The background color changes according to the current state:
TX Power	Green: No error
RX Power	Yellow: Low/high warning flags
Temperature	Red: Low/High alarm flags
Vcc	Grey: No DMI available
TX Bias	

Statistics Panel

The Statistics panel shows the data transmission and reception statistics for the media ports. This information can be used to see the level of network utilization and to know if the level of media traffic is at or near the rated network bandwidth. A saturated network will result in packet loss at the receiver.

	ETH1		ETH2	
	RX	TX	RX	TX
Packets	975,926,230	1,046,335,810	976,510,032	1,048,330,383
Bandwidth (Mbps)	3,982	20,723	3,982	20,723
Bandwidth peak (Mbps)	4,423	23,017	4,383	22,808
Reset counter	Reset	N/A	Reset	N/A

Figure 14-10: *Statistics Panel*

When Reset is clicked, the current date and time is shown as a record of how long the packet counters have been running.

NMOS Panel

The XIP-3901-ASI supports Networked Media Open Specifications (NMOS) AMWA IS-04 for device discovery and registration and IS-05 for connection management. Furthermore, it supports AMWA BCP-002 recommendations for Grouping NMOS Resources.

The XIP-3901-ASI relies on an external NMOS registry that is used to register NMOS devices. You must point the XIP-3901-ASI to this external NMOS registry.

PREREQUISITE: A working NMOS registry service must be available on the network.

Global		Registry IS-04	
Mode	IS-04 & IS-05	Registry mode	Static
Label	XIPMB10	HTTP address	10.37.72.24
Registration status	Registered	Registration port	4041
		Query port	4041

Figure 14-11: *NMOS Panel*

Property	Description
Mode	Set the NMOS mode: IS-04: enable the Networked Media Open Specifications (NMOS) IS-04 v1.2 or higher for device discovery and registration. All senders will publish and update SDP file, but receivers can't be updated. IS-04 & IS-05: enable the NMOS IS-04 for device discovery and registration and IS-05 for connection management. All senders will publish and update an SDP File and receivers will accept routing request and process the received SDP file. OFF: disable NMOS. This eliminates the RED status when NMOS IS-04 is not used. This is the default.
Label	Set the identifier by which this XIP-3901-ASI card will be known in the NMOS registry, and by extension, to other NMOS devices using this NMOS registry.

Property	Description
Registration Status	Shows if the card has successfully registered itself in the NMOS registry. Green: the card has successfully registered itself with the NMOS registry. Red: the card is not yet registered with the NMOS registry. Grey: NMOS is disabled (Mode is OFF).
Registry IS-04, Registry Mode	Set the IS-04, Registry Mode: Auto: automatic discovery of the NMOS registry using DNS Service Discovery (DNS-SD), as described in AMWA IS-04 NMOS Discovery and Registration Specification v1.2. Static: manually specified NMOS registry values for address, registration port and query port. In this mode, by specifying a registry address in the same subnet as one of the interfaces, the interface will be used. However, when specifying an address in a different subnet, the first available interface will be used in the following order: FRM, ETH3, ETH1 , and then ETH2 . The default Registry Port value is 3210. The default Query Port value is 3211.
HTTP Address	Set the NMOS registry's IP Address when the Registry IS-04, Registry Mode is Static .
Registration Port	Set the NMOS registry's registration port number when the Registry IS-04, Registry Mode is Static .
Query Port	Set the NMOS registry's query port number when the Registry IS-04, Registry Mode is Static .

Info Panel

When this card is used in a control system such as GV Orbit, certain information about the card can be made available to control system.

Card Info	Device type	XIP-3901-ASI
	Description	ASI/IP Gateway
	Manufacturer	Grass Valley
	Vendor	Grass Valley
	Card Model	XIP-3901
	Rear Type	XIP-3901-3+DRP
	Firmware version	1.0.0.119
	PCB version	0.1.1
	Serial number	306501-135520009
	REST API	http://10.37.27.70/api/
REST API documentation	http://10.37.27.70/api/doc	

Figure 14-12: Info Panel

Property	Description
Device type	Shows the card's current application.

Property	Description
Description	Shows a short description of the card.
Manufacturer Vendor	Shows information about the card's manufacturer.
Card Model	Shows the card's model number.
Rear Type	The rear panel model number paired with the card.
Firmware version	The card's current firmware version.
PCB version	The card's hardware version.
Serial number	The card's serial number.
REST API	Click to see the Card's REST API. With this interface, you can create your own interface for this card. This requires a web development effort to achieve this.
REST API documentation	Click to see the Card's REST API documentation, for information about the card's REST API interface.

Friendly Names Panel

You can enter labels and comments that will make this card easy to identify in a complex setup. This information is entered into data boxes in the **Friendly Names** part of the panel.



Application	Name	
XIP-3901-ASI	XIP-3901-ASI	
Channels	Name (ASI to IP)	Name (IP to ASI)
Channel 1	ASI-to-IP1	IP-to-ASI1
Channel 2	ASI-to-IP2	IP-to-ASI2
Channel 3	ASI-to-IP3	IP-to-ASI3
Channel 4	ASI-to-IP4	IP-to-ASI4
Channel 5	ASI-to-IP5	IP-to-ASI5
Channel 6	ASI-to-IP6	IP-to-ASI6
Channel 7	ASI-to-IP7	IP-to-ASI7
Channel 8	ASI-to-IP8	IP-to-ASI8

Figure 14-13: Friendly Names Panel

Property	Description
Application	Shows the card's current application.
Name	Set and customize the name of the card's application. This also changes the name for this card in the title at the top of the web page.
Name (ASI to IP) - Channel 1: to Channel 8	Set the name by which each channel will be easily recognized by a person working with this card in a control system such as GV Orbit. This also changes the name for all 8 (ASI to IP) channels in the title at the top of the web page.
Name (IP to ASI) - Channel 1: to Channel 8	Set the name by which each channel will be easily recognized by a person working with this card in a control system such as GV Orbit. This also changes the name for all 8 (IP to ASI) channels in the title at the top of the web page.

Alarm Configuration Panel

This panel is used to configure the alarm reporting of the XIP-3901 application. It has an expandable tree listing all the alarms reported by this XIP-3911 or XIP-3901 card.

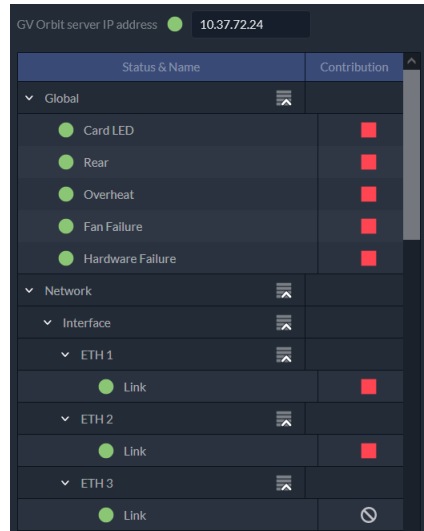
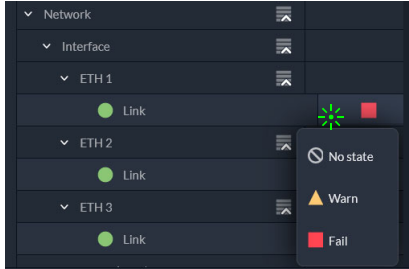

Figure 14-14: Alarm Configuration Panel

Property	Description
GV Orbit server IP address	<p>Alarms from the card can be sent to GV Orbit to be taken into account in its alarm list and alarm logging.</p> <p>When a GV Orbit server is present on your network, set the IP address of:</p> <ul style="list-style-type: none"> • The GV Orbit server's Management port. • The GV Orbit server's Virtual IP address when this is configured, such as in the case of a GV Orbit cluster, for example. <p>Furthermore, the GV Orbit Alarm API service must have its Enable Write Access property set to enabled.</p> <p>See the GV Orbit Admin Guide for more information about the configuration of:</p> <ul style="list-style-type: none"> • IP addresses for a GV Orbit server. • GV Orbit Alarm API service.
Status/Name	<p>This column contains an expandable tree listing all the alarms reported by this XIP-3901-ASI application.</p> <ul style="list-style-type: none"> • Each alarm name includes an icon that shows its current status.

Property	Description
Contribution	<p>Apart from the Global alarms, click a Contribution column item to set the severity level of each individual alarm to the alarm named in the column heading. This applies to the front card -edge LED and to the alarms reported to GV Orbit. See Front Card-edge Interface, on page 41.</p>  <p>Black icon: The alarm makes no contribution. Yellow icon: The alarm is of minor importance (warn). Red icon: The alarm is of critical importance (fail).</p>
Global: Card LED	This shows the current status of the status LED located on the front card-edge. If at least one Critical or Fail alarm is triggered, the LED will change to red. If no Fail alarms are triggered and Warn alarms are occurring, the LED will change to yellow.
Rear	These are the card's master alarms.
Overheat	
Fan Failure	
Hardware Failure	
Network	
Network	These are alarm categories. Expand the category to see the available alarms.
NMOS	
<i>Receivers</i>	
Senders	
Inputs / Outputs	

Factory/Presets Panel

This panel provides access to three functions, which apply only to the current application.

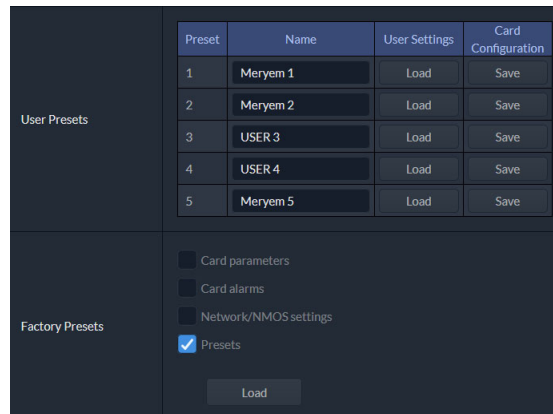
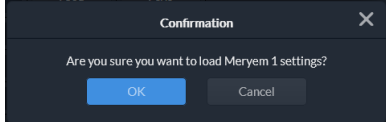
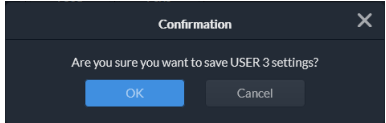

Figure 14-15: Factory/Presets Panel (Shown on XIP-3901-UC)

Property	Description
User Presets	<p>Preset: Each XIP-3901 application has memory registers that can hold up to five user-defined parameter settings.</p> <p>Name: Set a name or rename a preset by typing a new name in the preset Name field. (up to 16 characters)</p> <p>User Settings: Click Load to load the contents of the user preset into the XIP-3901 application. All parameter settings and values will be replaced by the contents of the selected user preset. However, this will not load the IP configuration of the card's Ethernet configuration.</p> <p>A confirmation box will pop up to allow you to proceed or cancel the load.</p>  <p>Figure 14-16: Load User Settings Confirmation Box</p> <p>Card Configuration: Click Save to store the current parameter settings and values from the XIP-3901 application in the selected user preset. The existing contents of the preset will be overwritten. A confirmation box will pop up to allow you to proceed or cancel the save.</p>  <p>Figure 14-17: Save Configuration Confirmation Box</p>

Property	Description
Factory Presets	<p>Click Load to restore the card to a factory default state when one or more checkboxes are selected to reset the following:</p> <p>Card parameters: Any configuration setting you have made are reset to their default settings.</p> <p>Card alarms: Alarm contribution settings are set to their default values.</p> <p>Network/NMOS settings: The card's IP interface configuration and NMOS settings are reset to their default values.</p> <p>Presets: The above User Preset are cleared and the preset labels are reset to their default values.</p>

Applications Panel

This panel is used to activate or switch between applications. It shows all the applications on the platform, their respective versions, whether their license keys have been activated, and which one is currently **In Use**.

Application	Version	Activation	License	In Use
XIP-3901-UC	1.3.0	Activate	●	●
XIP-3901-DC	1.3.0	Activate	●	●
XIP-3901-FS	1.2.0	Activate	●	●
XIP-3901-UDC-IP	1.6.1	Activate	●	●
XIP-3901-UDC-S1	2.0.4	Activate	●	●
XIP-3901-ASI	1.0.0.119	Activate	●	●

! To activate an application, please contact Grass Valley customer service at +1-514-333-1772, and specify the application's name and the card's serial number 306501-135520009.

Figure 14-18: Applications Panel

Until an application has been activated, the SDI / IP outputs will be inactive. Although the settings can be adjusted for an application, the effects will only become apparent when the license key has been activated.

Activating an Application

- 1 Call Grass Valley at the number displayed at the bottom of the panel and provide your serial number to receive a license key.
- 2 In the License column for the application, enter the license key and click **Activate**.

Application	Version	Activation	License	In Use
XIP-3901-UC	2.0.0.389	Activate	●	●
XIP-3901-DC	2.1.0.276	Activate	●	●
XIP-3901-FS	2.0.0.130	Activate	●	●
XIP-3901-UDC-IP	1.3.1.443	Activate	●	●
XIP-3901-UDC-IF	3.1.0.79	Activate	●	●
XIP-3901-JPEG-XS	1.0.0.207	Activate	license key <input type="text"/> Activate	●

XIP-3901-XXC is a software key that identifies applications on the XIP-3901 platform.
! To activate an application, please contact Grass Valley customer service at +1-514-333-1772, and specify the software key and the card's serial number 306501-131591027.

Figure 14-19: Applying a License Key to an installed Application

Once an application has been activated, it cannot be deactivated.

Switching to a Different Application

- 1 Select the **In Use** radio button for the application you want to change to.

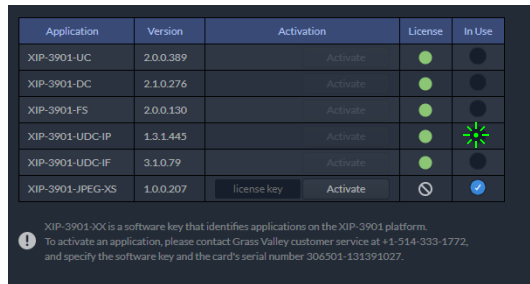

Figure 14-20: Applications Panel

- 2 In the Confirmation dialog box, click **OK**.

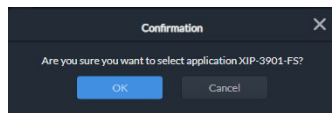

Figure 14-21: Confirmation

- 3 Wait several seconds for the application to reboot.

Upgrade Panel

See [Card Upgrade](#), on page 263.

Technical Support Panel

Property	Description
Contact	If you have any questions or suggestions, contact Grass Valley Technical Support.
Reboot Card	Click to reboot the card
System Snapshot	A system snapshot creates a compressed file that contains information that can be used by Grass Valley Technical Support for troubleshooting purposes. Proceed as follows: <ol style="list-style-type: none"> 1 Click Generate. 2 Click Download snapshot when this appears. 3 Save the file to your PC's hard disk. 4 Send the file to Grass Valley Technical Support for analysis.

15

Maintenance & Troubleshooting

XIP-3901-UC, XIP-3901-DC, or XIP-3901-FS	XIP-3901-UDC-IP	XIP-3901-UDC-IF	XIP-3901-GB-IP	XIP-3901-JPEG XS, or XIP-3901-ASI
•	•	•	•	•

Maintenance

Field Replaceable Units

The following components are Field Replaceable Units (FRUs). The repair procedure is to swap in a new (known good) component to restore system operation.

Description	See
Cooling fan	Cooling Fan Operational Assessment , on page 328.

There are no user-serviceable parts within these components except for the XIP-3911 & XIP-3901 in which the heatsink cooling fan can be replaced. See [Cooling Fan Operational Assessment](#), on page 328.

Contact Technical Support to order an FRU. See [Grass Valley Technical Support](#), on page 354.

Replacing Cards

Use a field-supplied Phillips #2 screwdriver to remove and install rear panels. All cards and rear panels can be installed with the frame power on.

Each card has connectors which plug into a mid-frame mother board for distribution of power and for connection to the controller card, and a second connector which plugs directly into the rear panel to support rear panel connections.

IMPORTANT

The rear panel must be installed before the XIP-3911 & XIP-3901 is inserted into the frame.

The XIP-3911 & XIP-3901 must be removed from the frame before the rear panel can be removed.

Replacing a rear panel

To replace a rear panel in a Densité frame

- 1 If a card is already installed in a modular card slot served by the rear panel you are changing, remove it first (see [Removing a card](#), on page 328).
- 2 Remove the existing rear panel (either blank or belonging to an existing card) by releasing the captive screws at the bottom.
There may be several captive screws, depending on the card type.
- 3 Position the new panel and secure it in place with the captive screw(s) at the bottom.

Removing a card

To remove a card

- 1 Open the front door of the frame.
- 2 Lift up the card ejector handle on the front of the card you want to remove, to lever the connectors apart, and then use the handle to pull the card straight out of the modular card slot.
- 3 Close the front door of the frame.

Installing a Card

Note:

The rear panel must be installed before the card. See [Replacing a rear panel](#) on page 328.

See [Installation of the Rear Connector Panel and Card](#), on page 48.

Cooling Fan Operational Assessment

A cooling fan has moving parts that, over time, can wear out. In the final stages of fan wear out, the fan makes a distinctive sound and it rotates at a slower speed, thereby reducing airflow which undermines its ability to remove heat from the XIP-3911 & XIP-3901. Under this condition, fan replacement is required.

Also, dust contained in the ambient air can accumulate on the fan and on surfaces around the fan and heatsink, thereby reducing airflow, and preventing air from coming into direct contact with the heatsink surfaces which undermines the ability to remove heat from the XIP-3911 & XIP-3901. Under this condition, cleaning is necessary and fan replacement may be required.

Some diagnostic procedures may interrupt normal system operation. Changing the XIP-3911 & XIP-3901's cooling fan will interrupt normal system operation. Down time can be minimized by swapping in another known good XIP-3911 & XIP-3901 to restore system operation quickly. Schedule these maintenance operations during off hours when the system is not in use.

Diagnostics

The XIP-3911 & XIP-3901's electronic circuitry generates heat that must be shed by forcing air to move across heat-generating components. Reduced air flow or high ambient

temperature results in heat build-up within temperature-sensitive components within the XIP-3911 & XIP-3901. This can cause unexpected behavior such as glitches or even a system freeze or shutdown. The XIP-3911 & XIP-3901 self-diagnoses high temperature conditions by raising critical temperature and fan alarms.

Critical temperature and fan alarms are reported through the following mechanisms:

- The **Hardware Overheating** alarm is reported in the Alarms Configuration panel.
- A XIP-3911 & XIP-3901's Densité status LED flashes red due to this condition (note that the Status LED can also flash due to other conditions).

The fan alarm indicates that the fan:

- Is not rotating fast enough due to wear and thus it may not provide enough cooling.
- Has become unplugged from Power Connector **Fan1**. See [Cooling Fan Replacement Procedure](#), on page 330.

Critical Temperature Alarm Corrective Actions

If the critical temperature alarm is active, then undertake the following diagnostic steps in the following order:

- 1 Confirm that the room temperature is within XIP-3911 & XIP-3901's operating temperature range specification. If necessary, take corrective actions by, for example, increasing the amount of air conditioning made available to the Densité frame.
- 2 Confirm that air flow around the Densité frame is not obstructed. If necessary, take corrective actions by, for example, removing obstructions or rerouting cables around and away from the Densité frame.
- 3 When the previous corrective actions do not eliminate a critical temperature alarm, verify that the XIP-3911 & XIP-3901's onboard fan is working correctly. See [Fan Noise](#) below.

Fan Noise

Over time, a fan's performance (operating speed) can degrade which may raise critical temperature and fan alarms. Under this circumstance, a fan may emit a rough-sounding lower pitched sound as compared to the sound that other healthier fans emit. To confirm that the XIP-3911 & XIP-3901 has an abnormally-sounding fan, during off hours when the system is not in use, eject the XIP-3911 & XIP-3901 card from the frame to verify that the distinctive sound stops and take corrective actions (see below).

Fan Alarm and Fan Noise Corrective Actions

When a fan alarm is raised, it must be addressed right away. During off hours when the system is not in use, eject the XIP-3911 & XIP-3901 card from the frame and inspect the XIP-3911 & XIP-3901's fan assembly: remove any accumulated dust and dirt from within the XIP-3911 & XIP-3901 with compressed air and remove any obstruction to the fan's ability to freely rotate.

Re-apply power to the XIP-3911 & XIP-3901 and restore system operation to see if the fan alarm becomes inactive.

The XIP-3911 & XIP-3901's onboard circuitry monitors the fan motor's rotational speed to detect that the fan is rotating fast enough to provide sufficient cooling; it raises a fan alarm when the fan's rotational speed has gone below a factory-set threshold.

When the XIP-3911 & XIP-3901's fan is not rotating fast enough (as detected by a fan alarm), is making abnormal noises, or is not rotating at all, the fan is worn out and it must be replaced with a new one.

Replacing the XIP-3911 & XIP-3901's Fan

Fan Replacement Kit

The replacement fan kit is available by contacting Technical Support. See [Grass Valley Technical Support](#), on page 354.

Required Tools

The following field-supplied material is required:

- Compressed air to remove dust from the XIP-3911 & XIP-3901.
- Needle-nose pliers to separate push pins from the PCB.
- Curved tweezers to disconnect the fan's power connector from the XIP-3911 & XIP-3901's main board.
- Anti-static bag or anti-static work surface to reduce the possibility of electrostatic discharge damage to the XIP-3911 & XIP-3901's electronics.

Cooling Fan Replacement Procedure

The cooling fan is located on the XIP-3911 & XIP-3901 PCB card.

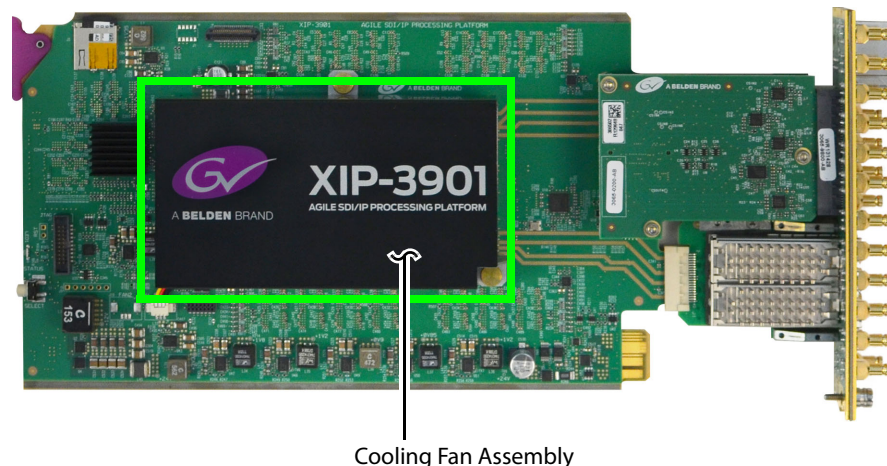

Fig. 15-1: Fan Assembly on the XIP-3901 Card

Required Materials

To replace the fan assembly on the XIP-3911 or XIP-3901 card, you will need:

- XIP-3911 or XIP-3901 Fan Assembly Replacement Kit

- Anti-static mat
- Needle-nose pliers
- Tweezers

Procedure

Step 1: Remove the failed fan assembly

- 1 During off hours when the system is not in use, eject the XIP-3911 & XIP-3901 card from the Densité frame.
- 2 Flip the card over on an anti-static mat so that you can see the rear (solder side) of the card.
- 3 Using needle-nose pliers, compress the two pushpins so that they unlatch. Push the pin through the card to release it from the assembly.

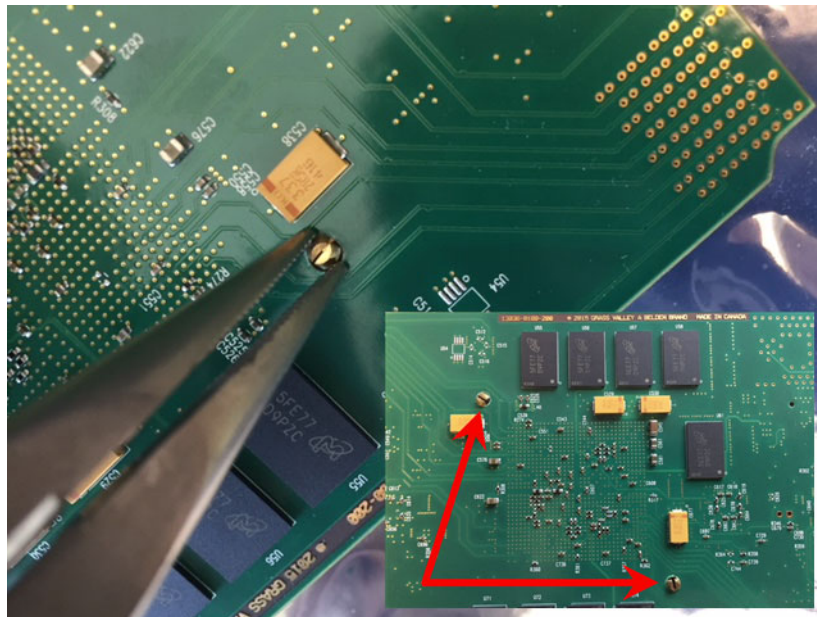

Fig. 15-2: Compressing the Pushpins

- 4 Flip the card back to the component side. Insert the pliers under the one of the pushpin heads. Press down on the center of the fan assembly to prevent it from flipping on its side and gently pry the pin from the heatsink assembly. Repeat for the second pushpin.

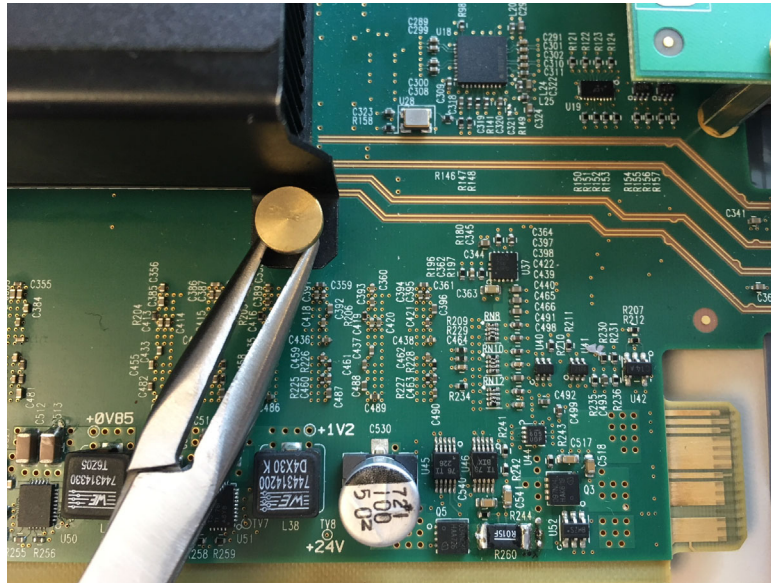
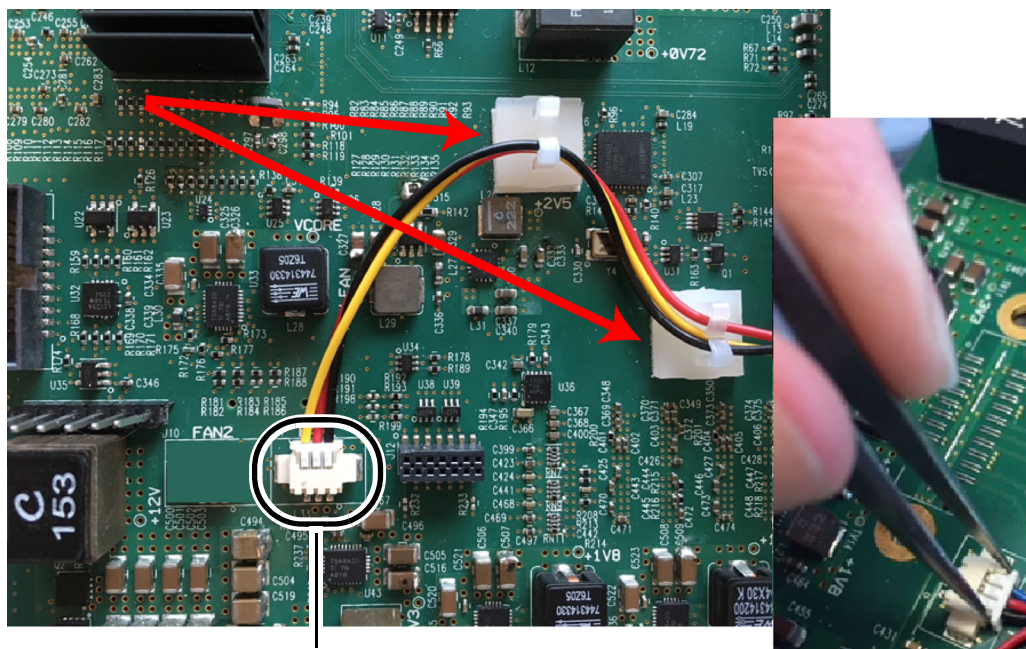

Fig. 15-3: Prying Out the Pushpins

- 5 Remove the wires from both wire clips on the fan assembly.
- 6 Note the position of the black wire to assist with reconnecting the replacement assembly.
- 7 Use tweezers to gently disconnect the power connector on the fan assembly from the card.



Power Connector FAN 1

Fig. 15-4: Removing the Wires and Connector

- 8 Dispose of the failed fan assembly.

Step 2: Install the new fan assembly

- 1 Connect the power connector for the replacement fan assembly to the FAN 1 jack on the card.
- 2 Insert the wires for the fan assembly into the wire clips.
- 3 Place the fan assembly on the heatsink and align the two pushpins with their respective holes on the card.
- 4 Press down on the fan assembly to hold it in place and press the pushpins into the holes until they lock into place.

Troubleshooting

Following a methodical process of elimination, try the following steps.

- 1 Are you using the latest XIP-3911 & XIP-3901 firmware?

To upgrade	Configuration Interface		See
	iControl	Web Browser	
XIP-3901-UC, XIP-3901-DC, or XIP-3901-FS	●		Card Upgrade with iControl Solo , on page 71
XIP-3901-UDC-IP	●		
XIP-3901-UDC-IF	●		
XIP-3901-GB-IP	●		
XIP-3901-JPEG-XS		●	Card Upgrade , on page 263
XIP-3901-ASI		●	Card Upgrade , on page 263

- 2 The Status Indicators on the XIP-3911 & XIP-3901 show if it is powered and these indicators provide troubleshooting information. See [Front Card-edge Interface](#), on page 41.
- 3 Make sure the fiber connectors are clean, as the problem is often related to dust obstructing the light at the fiber connections. See [Keep Fiber Connections Clean](#), on page 334.
- 4 Use another fiber connection.
- 5 Swap components of the XIP-3911 & XIP-3901 with known working components, one component at a time in a systematic fashion to further isolate the issue. For example, swap the SFP transceiver cartridges or use a different port on the network switch.

Further troubleshooting.

Problem	Possible solutions...
SFP n Status LED is blue flashing even with a fiber present	<p>Make sure you are using the right multi-mode fiber type. By convention, the cable should be orange.</p> <p>Make sure the fiber connector is properly seated in the SFP cartridge.</p> <p>Make sure the media network switch is a powered-up.</p> <p>Make sure the total loss in the optical path is not greater than 2.5 dB, due to any combination of factors mentioned here. Measure the loss if necessary.</p> <p>Check the fiber for any damage. The fiber cannot have small circumference loops.</p> <p>Check the fiber connectors for dirt and debris. See Keep Fiber Connections Clean, on page 334.</p> <p>Make sure your fiber length is within the range of the media network switch and of the SFP cartridge's specification.</p> <p>Note: depending on fiber type, and if splices are done on your fiber, the actual maximum usable length will be reduced.</p>
Densité status LED is off	<p>Make sure the card is fully inserted into the frame and that the frame is powered.</p>
Interpretation of status LEDs	<p>Status LEDs show the card's current operating status. See Front Card-edge Interface, on page 41 for more information.</p>

When contacting Grass Valley Technical Support, they may ask for product information. This is found in the **Info** panel. See [Info Panel](#), on page 258 or [Info Panel](#), on page 299.

Keep Fiber Connections Clean

Safety First:

- Never assume a fiber is dark. Never look directly into the end of a fiber cable. All people in the area must wear laser safety glasses with side shields.
- Installing connectors on a fiber requires special handling procedures. Read and follow the fiber and connector manufacturer's instructions.

The physical interface between the optical fiber and the fiber port of the SFP cartridge is the critical point in the system. The fiber and the optical port must be accurately aligned – that's the job of the connector plugs and sockets – and be in intimate contact with no obstructions. This is your job. The small size of the fiber, and the even smaller size of the fiber core, means that even common dust particles can seriously impair the transfer of light from one fiber to another.

There are a variety of cleaning solutions available to help you maintain good fiber network performance. For best results, it should be possible for you to perform a visual inspection of the fiber ends to verify cleanliness.

Grass Valley strongly urges you to select a cleaning method that meets your needs, and to use it rigorously and consistently.

A few tips:

- When an optical fiber is disconnected from the SFP module's optical port, always:

- Insert a dust plug into the empty SFP module's optical port.
- Install caps on the open end of the fiber optic cable.

This keeps airborne particles from settling on the fiber end or in the SFP module's optical port.

- Keep your dust plugs and caps clean – always store them in a sealed container to prevent the transfer of dust to the fiber connectors when used in the future.
- Always follow the instructions carefully when cleaning – abrasions on the fiber ends can degrade system performance significantly.
- A visual inspection will ensure that particles and liquid residue have been removed.
- If it's still dirty, clean it again.

Note: The SFP module's optical ports cannot be cleaned.
If dust enters the SFP module's optical port to the point where performance degrades, the corrective action is to replace the damaged SFP module with a new one.

16

Technical Specifications

XIP-3901-UC, XIP-3901-DC, or XIP-3901-FS	XIP-3901-UDC-IP	XIP-3901-UDC-IF	XIP-3901-GB-IP	XIP-3901-JPEG XS	XIP-3901-ASI
●	●	●	●	●	●

SDI (Inputs/Outputs); XIP-3901UC / DC / FS & XIP-3901-UDC-IF Applications

Physical:	16 DIN connectors: 8 IN, 8 OUT
SDI Standard:	SMPTE ST 292 (1.485, 1.485/1.001 Gbps)
	SMPTE ST 424 (2.970, 2.970/1.001Gbps)
	SMPTE ST 2082-1:2015 (on DIN IN 1 & 5 and OUT 1 & 5)
Supported formats:	HD: SMPTE ST 274: 1080i59.94, 1080i50
	HD: SMPTE ST 296: 720p59.94, 720p50
	3G: SMPTE ST 425 Level A (mapping 1), level B: 1080p59.94, 1080p50
	4K UHD: Quad Link 3 Gbps SMPTE ST 425-5: 1080p59.94, 1080p50
	12G: SMPTE-2082-10: 2160p59.94, 2160p50
Cable length (Belden 1694A):	HD: 250m (820 ft.) at 1.485 Gbps
	3G: 150m (492 ft.) at 2.970 Gbps
	12G: 60m (197 ft.) at 11.88 Gbps
Jitter:	HD: <0.2 UI (alignment jitter)
	3G: <0.3 UI (alignment jitter)
	12G: <0.3UI (alignment jitter)

Reference Input; XIP-3901UC / DC / FS Applications

Signal:	SMPTE ST 170 / SMPTE ST 318M / ITU 624-4 blackburst
---------	---

Ethernet Port (Control)

Physical:	1 RJ45 port
Standard:	IEEE 802.3 1,000 Mb/s Ethernet

Media Ports; XIP-3901-UDC-IP, XIP-3901-UDC-IF, & XIP-3901-GB-IP Applications

Physical:	Two SFP+ sockets
Performance:	Up to 25 Gbps of streaming per direction
Compatible SFP+ Cartridges:	GV SFP-25G-SR: SFP28 25GBASE Optical Transceiver MMF

Technical Specifications

	GV SFP-25G-LR: SFP28 25GBASE Optical Transceiver SMF
	Cisco SFP-25G-AOC-xM: 25GBASE Active Optical SFP28 Cable 2, 3 and 5 meters
Timing:	SMPTE ST 2059-1 & -2 precision time protocol with best master clock algorithm
Video Processing Performance	
Signal path:	10 bits minimum
Latency, no reference:	33 ms (59Hz)
	40 ms (50Hz)
Latency, with reference:	28 ms to 61 ms (59Hz)
	32 ms to 72 ms (50Hz)
3G Output Minimum Delay:	Fewer than 4 video lines
Electrical	
Power:	60 W maximum:
	XIP-3901-UDC-IP
	XIP-3901-UDC-IF
	XIP-3901-JPEG-XS
	XIP-3901-UC / -DC / -FS
	XIP-3901-GB-IP

A

Local Menu

XIP-3901-UC, XIP-3901-DC, or XIP-3901-FS	XIP-3901-UDC-IP	XIP-3901-UDC-IF	XIP-3901-GB-IP	XIP-3901-JPEG XS, or XIP-3901-ASI
●	●	●	●	●

1st Level	2nd Level	3rd Level	4th Level	Comments/Default Value
Status	Current Application			XIP-3901-UC, XIP-3901-DC, XIP-3901-FS, XIP-3901-UDC-IP, XIP-3901-UDC-IF, XIP-3901-GB-IP, XIP-3901-JPEG-XS, XIP-3901-ASI
	ETH1	LINK STATUS		
		IP ADDRESS		
		NETMASK		
		GATEWAY		
		MAC ADDRESS		
	ETH2	as per ETH1		
	ETH3	as per ETH1		
FRAME	as per ETH1			
NETWORK CONFIG	ETH1	MODE	STATIC, DHCP, OFF	
		IP ADDRESS	XXX.XXX.XXX.XXX	
		MASK	XXX.XXX.XXX.XXX	
		GATEWAY	XXX.XXX.XXX.XXX	
	ETH2	as per ETH1	as per ETH1	
	ETH3	as per ETH1	as per ETH1	
	FRAME	as per ETH1	as per ETH1	

Local Menu

1st Level	2nd Level	3rd Level	4th Level	Comments/Default Value
VERSION	X.Y.Z.B			X major Y minor Z revision B build
	FPGA: X.Y.Z.B			
	UBOOT: X.Y.Z			
APPLICATIONS	XIP-3901-UC vX.Y.Z.B			When present on platform
	XIP-3901-DC vX.Y.Z.B			When present on platform
	XIP-3901-FS vX.Y.Z.B			When present on platform
	XIP-3901-UDC-IP vX.Y.Z.B			When present on platform
	XIP-3901-UDC-IF vX.Y.Z.B			When present on platform
	XIP-3901-GB-IP vX.Y.Z.B			When present on platform
	XIP-3901-JPEG-XS vX.Y.Z.B			When present on platform
	XIP-3901-ASI vX.Y.Z.B			When present on platform

Installing the SFP Ethernet Module



Introduction

Installing and removing the SFP output interface cartridge requires special care. This annex describes the process.

Some rear panels incorporate one or two SFP interface(s). The interface consists of two parts:

- A socket on the rear panel into which an SFP interface module is plugged
- An SFP (Small Form-factor Pluggable) module that performs output medium translation to which connections are made for optical fibers, coaxial copper, and so on.

CAUTION

- SFP fiber Transmitter modules contain a class 1 laser, which emits invisible radiation whenever the module is powered up. Because the SFP is hot-swappable, the module may be powered up as soon as it is installed.
- DO NOT LOOK INTO AN OPERATING SFP FIBER MODULE'S CONNECTORS, AS EYE DAMAGE MAY RESULT.
- The SFP module is sensitive to electrostatic discharge (ESD). It is recommended that you use an ESD-preventive wrist strap grounded to the GV Node chassis while handling the SFP module.
- SFP modules are subject to wear, and their useful lifetime is reduced each time they are inserted or removed. Do not remove them more often than is absolutely necessary.
- Never remove or install an SFP fiber module with the fiber optic cables connected. Damage to the cables could result.
- The presence of dust and debris can seriously degrade the performance of an optical interface. It is recommended that you insert a dust plug into the SFP fiber module whenever a fiber optic cable is not connected.

Installing an SFP module

- 1 Make sure that the bale clasp lever is in the closed position.

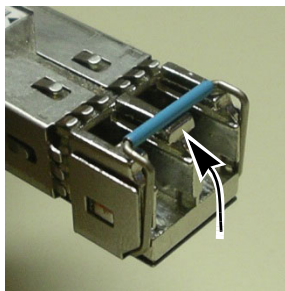

- 2 Position the SFP module so that the recessed slot is lined up with the tab side of the socket.

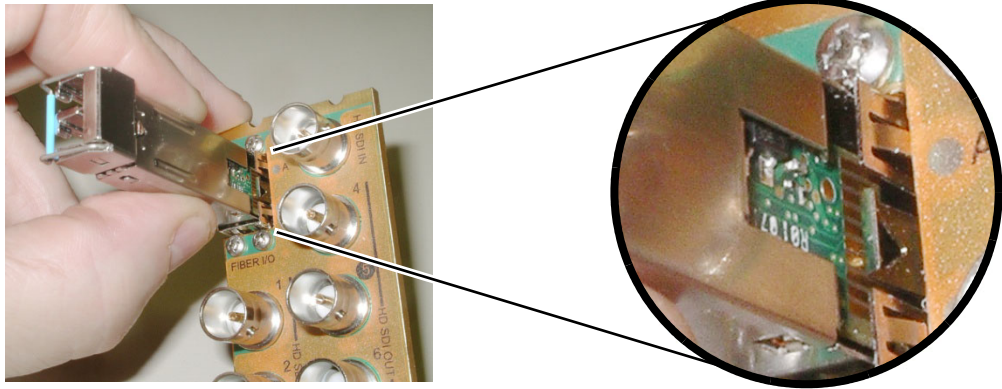

- 3 Slide the module straight into the socket, and push gently until it clicks into position.

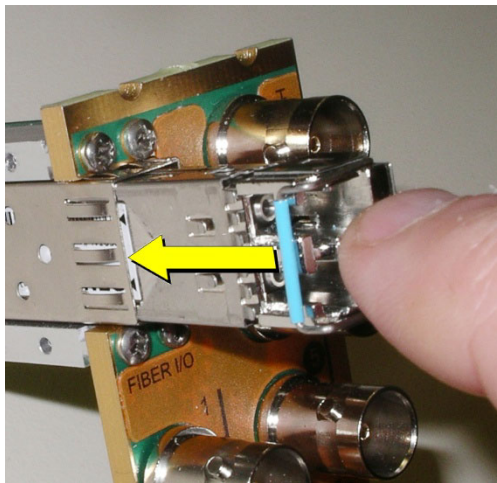

Connecting the fiber optic cables

- 1 Remove the dust plug from the SFP module if present
- 2 Verify that the exposed end of the optical fiber in the LC connector is clean
 - Carefully remove any debris if necessary.
- 3 Plug the LC-terminated fiber optic cable into the SFP module

Removing the fiber optic cables

- 1 Grasp the LC fiber optic connector that is plugged into the SFP module, and pull it straight out to disengage the optical fiber from the SFP.
 - Never pull the fiber optic cable itself, as irreversible damage may occur.
- 2 Insert a dust plug into the SFP module.
- 3 Install caps on the open end of the fiber optic cable.

Removing the SFP module

- 1 Move the bale clasp lever to the open position.

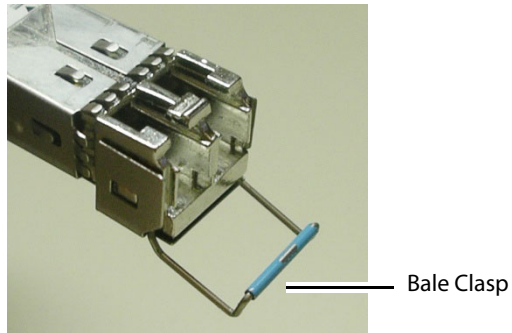

- 2 Grasp the SFP module between your thumb and forefinger, and pull it straight out of the slot.

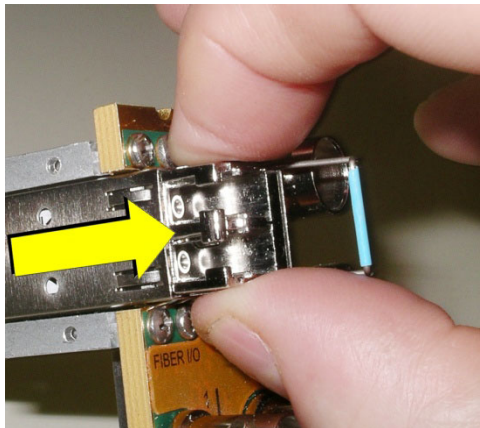

- Do NOT pull on the bale clasp lever to remove the module, as it is easily damaged.
 - You may find that you need to wiggle the module, or perhaps push it into the slot a bit, before it will release and slide out.
- 3 For fiber optic models, insert a dust plug into the SFP module.

BBC HLG Look-Up Table

XIP-3901-UC, XIP-3901-DC, or XIP-3901-FS	XIP-3901-UDC-IP	XIP-3901-UDC-IF	XIP-3901-GB-IP	XIP-3901-JPEG XS, or XIP-3901-ASI
●	●	●	●	

Introduction

To facilitate the introduction of HLG production, the XIP-3901-UDC-HDR option now includes the BBC R&D look-up tables (LUTs) release v1.4 which implement a range of key format conversions. The conversions are 33-cube 3D-LUTs including:

- BT.2100 PQ (1000 cd/m² nominal peak) to BT.2100 HLG
- BT.2100 PQ (4000 cd/m² nominal peak) to BT.2100 HLG
- BT.709 (SDR) to BT.2100 HLG (display-referred direct mapping maintaining SDR "look")
- BT.709 (SDR) to BT.2100 HLG (scene-referred direct mapping for matching cameras)
- BT.709 (SDR) to BT.2100 HLG (display-referred "up-mapping"/"inverse tone mapping" to maintain SDR artistic intent)
- BT.709 (SDR) to BT.2100 HLG (scene-referred "up-mapping"/"inverse tone mapping" for matching SDR and HDR cameras)
- BT.2100 HLG to BT.2100 PQ (1000 cd/m² nominal peak)
- BT.2100 HLG to BT.709 (SDR) (display-referred "down-mapping"/"tone mapping" maintaining HDR "look")
- BT.2100 HLG to BT.709 (SDR) (scene-referred "down-mapping"/"tone mapping" to match SDR cameras)
- S-Log3 SR-Live (BT.2020 color) to BT.2100 HLG (scene-referred conversion to match BT.2100 HLG cameras)

The scene-light LUTs will only work correctly with ITU-R BT.2100 signals. They will not color match cameras configured for Sony's "HLG Live" variant, nor the "Traditional Color" variant of HLG specified in ITU-R report BT.2390, described as "HLG Vivid" in Canon cameras.

LUT Details

Of the various licensed LUT from the BBC, the XIP-3911 or XIP-3901 will use Type II LUTs that are intended for full-range SDI input signals such as S-Log3 and those produced by some PQ devices and Type III LUTs are intended for LUT devices that process narrow-range video signals, but which operate over the full 10-bit signal range (0 to 1023). They will therefore pass sub-blacks (signals below 10-bit code value 64) and super-whites (signals above 10-bit

code value 940) (required for ITU-R BT.814 HDR PLUGE and ITU-R BT.2111 HDR Color Bars), so are most suitable for broadcast TV applications.

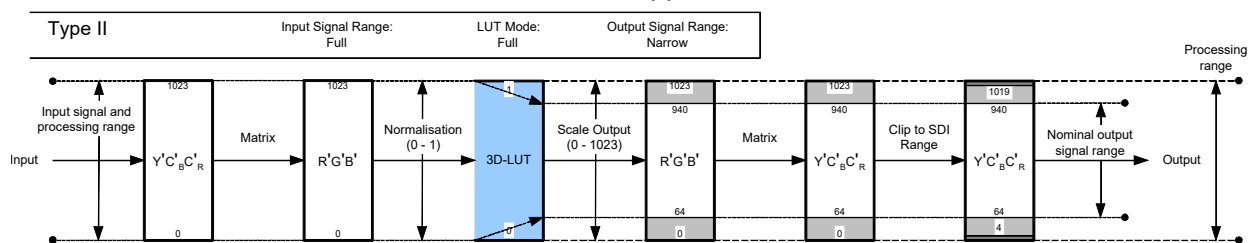

Fig. C-1: Type II signal scaling, intended for full-range input signals (for example, S-Log3)

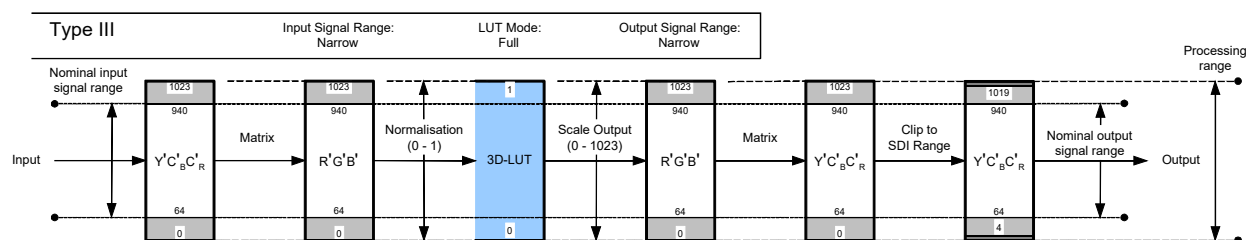

Fig. C-2: Type III signal scaling, primarily intended for hardware-based LUT applications

The Type II “full-range mode” LUT is used to convert full-range PQ and S-Log3 signals to HLG. So full-range Type II versions of the PQ1000, PQ4000, S-Log3 (100%) and S-Log3 (200%) conversion LUTs are provided.

We recommended only using narrow-range signals with HLG, to improve interoperability, maintain signal fidelity and reduce the likelihood of errors in production. So even when a hardware LUT device is operated in full-range mode, the HLG output signal is always offset and scaled within the full-range “container”, to lie within the usual narrow signal range of 64 to 940 (10-bits).

Scene-Light versus Display-Light Conversions

Most SDR/HDR format conversions are based on “display-light”. By that we mean that the conversion calculates the light produced by the original signal on a reference display operating in the original format, and attempts to produce a similar light output on a reference display operating in the new output format. Display-light conversions are designed to preserve the artistic intent of the pictures after conversion. So display-light conversions work well for graded content. An example of a display-light conversion for BT.709 to BT.2100 HLG is shown in the Figure below.

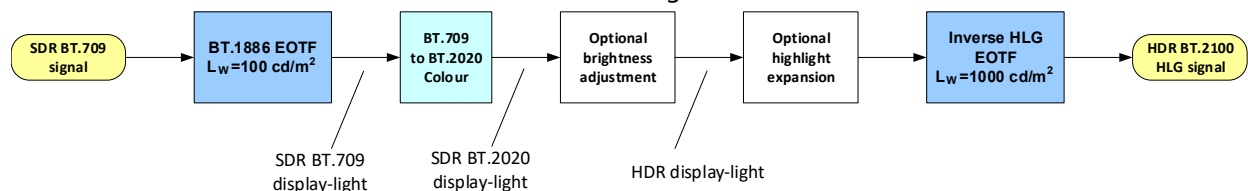

Fig. C-3: SDR to HDR Display-Light Conversion

For live production, however, it is usually more important to color match signals produced in different formats – for example a native BT.2100 HLG camera with an SDR BT.709 super

slo-mo camera. However, as the native displayed “look” of the SDR BT.709, SDR BT.2020, BT.2100 HLG, BT.2100 PQ and S-Log3 (SR-Live) production formats are all different (in terms of color and tone reproduction), color matching of cameras will be difficult using display-light conversions. Instead, a scene-light conversion should be used.

A scene-light conversion first calculates the light falling on the camera sensor by applying an inverse OETF, then any color space conversion and highlight expansion, and finally derives the output signal by applying the output format’s OETF. As the light falling on the camera sensor is the same regardless of production format, a more exact color and tone match is obtained than through display-light conversion. An example of a scene-light conversion for BT.709 to BT.2100 HLG is shown in the Figure below.

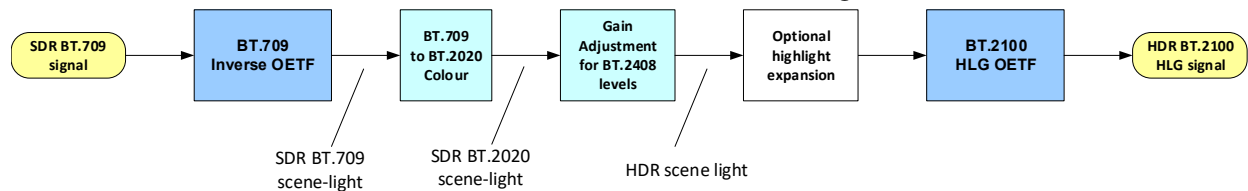

Fig. C-4: Scene-light SDR to HDR conversion

Scene-light conversions are also useful for HDR to SDR conversion, where the desire is to match the “look” of a traditional SDR camera. For example, the LUT 12 (scene-light conversion from BT.2100 HLG to SDR BT.709) should be used when a BT.2100 HLG production is required to provide an SDR BT.709 output that closely resembles the “look” of a traditional SDR BT.709 camera; perhaps for intercutting with SDR BT.709 cameras covering the same event in SDR.

More details can be found in section 7.1.3 of ITU-R report BT.2408, “Guidance for Operational Practices in HDR Television Production”.

The table below illustrates the recommended conversions for a range of different signal types and applications.

Table 2 – Recommended Conversions and LUTs

		BBC LUT	Conversion Type		SDR to HDR		HDR to SDR	HDR to HDR
			Scene-Light	Display -Light	Direct Mapping	Up-Mapping	Down-Mapping	Trans-code
Graded Content	SDR graded inserts	5		P		✓		
	SDR graded programs	3		✓	✓			
	HLG graded content	8		✓			✓	
	PQ graded content	1 or 2		✓				✓
Camera to switcher	SDR BT.709 camera	6	✓			✓		
	S-Log3 camera	10	✓					✓
	"S-Log3 Live" camera	11	✓					✓

Camera to SDR shading	HDR only camera	8 or 12	✓	✓			✓	
	SDR matching color branding	3		✓	✓			
Graphics	SDR matching in-vision signage	4	✓		✓			
	SDR complete	8		✓			✓	
Program Output	SDR "Clean Feed" for mixing with unilateral	12	✓				✓	
	PQ for onward	7		✓				✓

Extending the SDR Color Gamut

When matching SDR BT.709 cameras with BT.2100 HLG cameras, significantly better results can be obtained if the signal clippers on the SDR cameras are relaxed to EBU Technical Recommendation R103 signal levels (5%/+105%) and the conversion process takes account of the signals in the sub-blacks and super-whites. The sub-black and super-white signals produced by many cameras effectively increase the dynamic range and color gamut of the camera. More details can be found in ITU-R report BT.2250.

In order to exploit the extended SDR signal range, the conversion LUT has to operate in "full-range" mode, taking account of the black level offset of the SDR input signals (10-bit code value 64) (LUT Type III). Because of the improved performance, the scene-referred BT.709 to BT.2100 HLG direct mapping LUT (LUT 4) and up-mapping LUTs (LUT 6-1 and 6-2), are only provided in full-range mode (Type III) versions.

Output Signal Clipping

Type III LUTs with SDR BT.709 outputs are clipped within the look-up table to EBU Technical Recommendation R103 signal levels. In territories with stricter limits on the SDR signal range, an additional hardware legalizer may be needed.

The remaining Type II and Type III LUTs with PQ or HLG outputs are clipped to full-range, to ensure that they pass ITU-R BT.2111 HDR Color Bars. External processing, illustrated in [Type II signal scaling, intended for full-range input signals \(for example, S-Log3\)](#), on page 346 and [Type III signal scaling, primarily intended for hardware-based LUT applications](#), on page 346, is necessary to clip the LUT output to 10-bit SDI range (4 to 1019).

Table 3 – LUT Conversions and variant table

LUT Conversion	Description
SDR to HLG Scene (4-1a - v1.4)	For use with SDR cameras that approximate the BT.709 OETF with a square root BT.709 signals are directly mapped into BT.2100 HLG at the BT.2408 signal levels using a scene-light (scene-referred) conversion. The “look” of the original BT.709 content is changed to match native BT.2100 HLG cameras. 100% SDR signal is mapped to 75% HLG (HDR Reference White).
SDR to HLG Scene Strict (4-2a - v1.4)	For use with SDR cameras that implement a strict BT.709 OETF BT.709 signals are directly mapped into BT.2100 HLG at the BT.2408 signal levels using a scene-light (scene-referred) conversion. The “look” of the original BT.709 content is changed to match native BT.2100 HLG cameras. 100% SDR signal is mapped to 75% HLG (HDR Reference White). NOTE: Unlike BT.2100 HLG, SDR cameras that implement a strict BT.709 OETF tend to crush detail in the shadows of a scene. That detail will become more visible after applying this conversion.
SDR to HLG Scene Upmap (6-1a - v1.4)	For use with SDR cameras that approximate the BT.709 OETF with a square root. BT.709 signals are inverse tone mapped (up-converted) to BT.2100 HLG using a scene-light (scene-referred) conversion. The “look” of the original BT.709 content is changed to match native BT.2100 HLG cameras. Whilst the ITU-R BT.2408 signal levels are taken into account, a small boost is applied to the SDR highlights to better match natively produced HDR content. 100% SDR signal is inverse tone mapped to 79% HLG. 105% SDR signals (EBU R.103 signal levels) are inverse tone-mapped to 83% HLG.
SDR to HLG Scene Upmap Strict (6-2a - v1.4)	For use with SDR cameras that implement a strict BT.709 OETF BT.709 signals are inverse tone mapped (up-converted) to BT.2100 HLG using a scene-light (scene-referred) conversion. The “look” of the original BT.709 content is changed to match native BT.2100 HLG cameras. Whilst the ITU-R BT.2408 signal levels are taken into account, a small boost is applied to the SDR highlights to better match natively produced HDR content. 100% SDR signal is inverse tone mapped to 79% HLG. 105% SDR signals (EBU R.103 signal levels) are inverse tone-mapped to 83% HLG. NOTE: Unlike BT.2100 HLG, SDR cameras that implement a strict BT.709 OETF tend to crush detail in the shadows of a scene. That detail will become more visible after applying this conversion.
SDR to HLG Display (3c - v1.4)	Display-referred direct mapping maintaining SDR “look”. 100% SDR maps to 75 % HLG (HDR Reference White - see ITU-R BT.2408 and BT.2390). Recommended for matching the displayed color of SDR graphics.
SDR to HLG Display Upmap (5c - v1.4)	BT.709 signals are inverse tone mapped (up-converted) to BT.2100 HLG using a display-light (display-referred) conversion. This LUT is designed to complement LUT 8 (BT.2100 HLG to BT.709 tone mapping - display-light) to reduce round-tripping losses (SDR to HDR to SDR conversion). Whilst the ITU-R BT.2408 signal levels are taken into account, a modest boost is applied to the SDR highlights to better match natively produced HDR content. The LUT, however, attempts to preserve the artistic intent of the original BT.709 content. 100% SDR signal is inverse tone mapped to 83% HLG.

BBC HLG Look-Up Table
Output Signal Clipping

LUT Conversion	Description
HLG to SDR Scene (12-1c - v1.4)	<p>For use with SDR cameras that approximate the BT.709 OETF with a square root BT.2100 HLG signals are tone mapped (down-converted) to BT.709 using a scene-light (scene-referred) conversion. The “look” of the original BT.2100 HLG content is changed to match native BT.709 cameras with a square root approximation of the BT.709 OETF.</p> <p>This LUT is the exact inverse of LUT 6-1 (BT.709 to BT.2100 HLG inverse tone mapping - scene-light) to minimize round-tripping losses (SDR to HDR to SDR conversion). HDR Reference White (75% HLG) is tone mapped to 95% BT.709, allowing for some soft clipping of highlights. 79% HLG signal is tone mapped to 100% BT.709. For sub-blacks and super-whites, the LUT outputs are clipped to EBU R.103 signal levels.</p>
HLG to SDR Scene Strict (12-2c - v1.4)	<p>For use with SDR cameras that implement a strict BT.709 OETF BT.2100 HLG signals are tone mapped (down-converted) to BT.709 using a scene-light (scene-referred) conversion. The “look” of the original BT.2100 HLG content is changed to match native BT.709 cameras with a strict implementation of the BT.709 OETF.</p> <p>This LUT is the exact inverse of LUT6-2 (BT.709 to BT.2100 HLG inverse tone mapping - scene-light) to minimize round-tripping losses (SDR to HDR to SDR conversion).</p> <p>HDR Reference White (75% HLG) is tone mapped to 95% BT.709, allowing for some soft clipping of highlights. 79% HLG signal is tone mapped to 100% BT.709. For sub-blacks and super-whites, the LUT outputs are clipped to EBU R.103 signal levels.</p> <p>NOTE: Unlike BT.2100 HLG, SDR cameras that implement a strict BT.709 OETF tend to crush detail in the shadows of a scene. So shadow detail visible in the HDR image will become less visible after applying this conversion</p>
HLG to SDR Display (8c - v1.4)	<p>BT.2100 HLG signals are tone mapped (down-converted) to BT.709 using a display-light (display-referred) conversion. The LUT, therefore, attempts to preserve the artistic intent of the original HLG content, when converting to SDR. This LUT is designed to complement LUT 5 (BT.709 to BT.2100 HLG inverse tone mapping - display-light) to reduce round-tripping losses (SDR to HDR to SDR conversion).</p> <p>HDR Reference White (75% HLG) is tone mapped to 86% BT.709, allowing signal headroom for compressed highlights. 100% HLG signal is tone mapped to 100% BT.709. For sub-blacks and super-whites, the HLG super-white signals are tone-mapped to SDR super-white signals. The LUT outputs are clipped to EBU R.103 signal levels.</p> <p>In version 1.4, the LUT is brighter to correctly map the BT.709 equivalent color bars within the up-coming “EBU HDR Line-Up Bars” to 75% BT.709. There are also color saturation improvements over the v1.3.1 release</p>

LUT Conversion	Description
HLG to SDR Display Harsh (9c - v1.4)	<p>HDR-graded content and live programs with graphics - BT.2100 HLG to BT.709, downmapping (display-light) using SDR "super-whites".</p> <p>BT.2100 HLG signals are down-mapped (tone-mapped) to BT.709 using a display-light conversion. Colors and the appearance of mid-tones and lowlights are maintained after conversion. The LUT, therefore, attempts to preserve the artistic intent of the original HLG content.</p> <p>"HDR Reference White" (75% HLG) is mapped to 95% BT.709 and HDR highlights extend into the SDR super-white region; for that reason, only "Full-Range Mode" Type III LUTs are made available. 94% HLG signal is mapped to the EBU R103 preferred maximum of 105% BT.709. HLG signals above 94% are clipped.</p> <p>This LUT is recommended for use in scenarios where minimizing SDR>HDR>SDR "round-trip" losses is of the utmost importance. Minimal round-trip losses are achieved when used with the display-light up-mapping LUT5. Better overall results are, however, usually achieved with the LUT8 down-mapper, which does not rely on the SDR super-white signal ranges being maintained through the program delivery and distribution chains.</p>
PQ 1000 Nits Full Range to HLG (1c - v1.4)	<p>BT.2100 PQ signals are converted to BT.2100 HLG at the 1000 cd/m² "bridge" condition, so that 1000 cd/m² PQ maps to 100% HLG. See ITU-R report BT.2390 Section 7.2. PQ signals above 1000 cd/m² are mapped into the HLG "super-white" signal range up to a maximum of 1810 cd/m², corresponding to 109% HLG (10-bit code value 1019).</p>
PQ 1000 Nits Narrow Range to HLG (1e - v1.4)	<p>BT.2100 PQ signals are converted to BT.2100 HLG at the 1000 cd/m² "bridge" condition, so that 1000 cd/m² PQ maps to 100% HLG. See ITU-R report BT.2390 Section 7.2.</p>
PQ 4000 Nits Full Range to HLG (2c - v1.4)	<p>4000 cd/m² BT.2100 PQ signals are converted to BT.2100 HLG by first tone mapping to the 1000 cd/m² "bridge" condition, and then converting to HLG. The tone mapping is applied on the luminance component to avoid hue distortions. 4000 cd/m² PQ maps to 100% HLG. See ITU-R report BT.2390 Section 7.4</p>
PQ 4000 Nits Narrow Range to HLG (2e - v1.4)	<p>4000 cd/m² BT.2100 PQ signals are converted to BT.2100 HLG by first tone mapping to the 1000 cd/m² "bridge" condition, and then converting to HLG. The tone mapping is applied on the luminance component to avoid hue distortions. 4000 cd/m² PQ maps to 100% HLG. See ITU-R report BT.2390 Section 7.4. PQ signals above 4000 cd/m² are mapped into the HLG "super-white" signal range.</p>
HLG to PQ 1000 Nits Narrow range (7c - v1.4)	<p>BT.2100 HLG signals are converted to BT.2100 PQ at the 1000 cd/m² "bridge" condition, so that 100% HLG maps to 1000 cd/m² PQ. See ITU-R report BT.2390 Section 7.2. HLG signals above 100% are mapped to PQ signals greater than 1000 cd/m², up to a maximum of 1810 cd/m², corresponding to 109% HLG (10-bit code value 1019).</p>
SLog3 100% Scene to HLG (10a - v1.4)	<p>S-Log3 signals produced using the Sony's "100%" workflow (for example, 100% IRE input equals 90% reflectance) are converted to BT.2100 HLG with ITU-R BT.2408 signal levels. Thus a 100% IRE input signal (90% reflectance) maps to 73% HLG. A scene-light conversion is used, so that the converted S-Log3 signal matches the "look" of BT.2100 HLG cameras.</p>

BBC HLG Look-Up Table
Output Signal Clipping

LUT Conversion	Description
SLog3 200% Scene to HLG (11a - v1.4)	S-Log3 signals produced using the Sony's "200 %" workflow (for example, 200% IRE input equals 90% reflectance) are converted to BT.2100 HLG with ITU-R BT.2408 signal levels. Thus a 200% IRE input signal (90% reflectance) maps to 73% HLG. 200% workflows are common for "S-Log3 Live" productions. A scene-light conversion is used, so that the converted S-Log3 signal matches the "look" of BT.2100 HLG cameras.
Unity	Pass-through LUT



Grass Valley Technical Support

For details of our Regional Customer Support Offices, please visit the Grass Valley website and navigate to Support.

www.grassvalley.com/support/

Customers with a support contract should call their personalized number, which can be found in their contract, and be ready to provide their contract number and details.

Corporate Head Office

Grass Valley
3499 Douglas-B.-Floreani
St-Laurent, Quebec H4S 2C6
Canada
Telephone: +1 514 333 1772
Fax: +1 514 333 9828

www.grassvalley.com