

User Manual

Edition: 2011-08-23-2011

THOR-C **Media- / DVI-Converter**

Model:

TH-C-VGA-DVI

TH-C-MA-DVI

TH-C-MA-SDI-DVI

TH-C-MA-RGB-DVI

Telecast Fiber Systems
A Belden Brand

102 Grove Street
Worcester, MA 01605

www.telecast-fiber.com

Tel. +1 508-754-4858

Fax +1 508-752-1520

Copyright

© 2011. All rights reserved. This information may not be reproduced in any manner without the prior written consent of the manufacturer.

Information in this document is subject to change without notice.

Trademarks

All trademark and trade names mentioned in this document are acknowledged to be the property of their respective owners.

Disclaimer

While every precaution has been taken during preparation of this manual, the manufacturer assumes no liability for errors or omissions. Neither does the manufacturer assume any liability for damages resulting from the use of the information contained herein.

The manufacturer reserves the right to change specifications, functions, or circuitry of the product without notice.

The manufacturer cannot accept liability for damage due to misuse of the product or due to any other circumstances outside the manufacturer's control (whether environmental or installation related). The manufacturer shall not be liable for any loss, damage, or injury arising directly, indirectly, incidentally, or consequently from the use of this product.

Contents

1	About This Manual	6
	1.1 Scope.....	6
	1.2 Validity	6
	1.3 Cautions and Notes.....	6
2	Safety Instructions	7
3	Description	8
	3.1 Application	8
	3.2 System Overview	9
	3.3 Product Range	10
	3.4 Upgrade Kits	10
	3.5 Accessories.....	11
	3.6 Device Views	12
	3.6.1 Model TH-C-VGA-DVI.....	12
	3.6.2 Model TH-C-MA-DVI.....	13
	3.6.3 Model TH-C-MA-SDI-DVI.....	14
	3.6.4 Model TH-C-MA-RGB-DVI	15
	3.7 Status LEDs	16
4	Installation	17
	4.1 Package Contents.....	17
	4.2 System Setup.....	18
	4.3 Example Applications.....	19
5	Configuration.....	20
	5.1 Infrared Remote Control.....	20
	5.2 On Screen Display (OSD)	23
	5.2.1 Main Menu Item 'Color Settings'	24
	5.2.2 Main Menu Item 'Picture Settings'	26
	5.2.3 Main Menu Item 'Input Settings'	29
	5.2.4 Main Menu Item 'Output Settings'	30
	5.2.5 Main Menu Item 'General Settings'	31

- 6 Operation 35**
 - 6.1 Optimization of Picture Settings 35
 - 6.1.1 Optimization of Output Settings 36
 - 6.1.2 Optimization of Input Settings 36
 - 6.1.3 Optimization of Picture Settings 37
 - 6.2 Download of DDC Information 37
 - 6.2.1 Download of DDC by Infrared Remote Control ... 38
 - 6.2.2 Download of DDC via OSD 38
- 7 Specifications 39**
 - 7.1 Interfaces 39
 - 7.1.1 DVI-D Single Link..... 39
 - 7.1.2 DVI-I Single Link 39
 - 7.1.3 S-Video (Y/C)..... 39
 - 7.1.4 SDI Video..... 39
 - 7.1.5 EGA (D-Sub 9)..... 39
 - 7.1.6 Composite Video (BAS / FBAS)..... 40
 - 7.1.7 Component Video (YPbPr)..... 40
 - 7.1.8 RGB Video 40
 - 7.2 Supported Video Modes..... 41
 - 7.3 Connector Pinouts..... 49
 - 7.4 Power Supply..... 52
 - 7.5 Environmental Conditions 52
 - 7.6 Size 52
 - 7.7 Shipping Weight 53
- 8 Troubleshooting 54**
 - 8.1 Blank Screen..... 54
 - 8.2 Picture..... 55
 - 8.3 General 55
- 9 Technical Support 56**
 - 9.1 Support Checklist..... 56
 - 9.2 Shipping Checklist..... 56

10	Regulatory and Standards Compliance	57
10.1	CE Declaration Of Conformity.....	57
10.2	North American Regulatory Compliance	57
10.3	WEEE	58
10.4	RoHS	58
11	Glossary.....	59

1 About This Manual

1.1 Scope

This manual describes how to install your Media- / DVI-Converter, how to operate it and how to perform trouble shooting.

1.2 Validity

This manual is valid for all devices listed on the front page. The product code is printed on the base of the devices.

1.3 Cautions and Notes

The following symbols are used in this manual:



This symbol indicates an important operating instruction that should be followed to avoid any potential damage to hardware or property, loss of data, or personal injury.



This symbol indicates important information to help you make the best use of this product.

2 Safety Instructions

To ensure reliable and safe long-term operation of your Media- / DVI-Converter please note the following guidelines:

Installation

- Only use in dry, indoor environments.
- The Media- / DVI-Converter and the power supply units can get warm. Do not situate them in an enclosed space without any airflow.
- Do not place the power supply directly on top of the device.
- Do not obscure ventilation holes.
- Only use power supplies originally supplied with the product or manufacturer-approved replacements. Do not use a power supply if it appears to be defective or has a damaged case.
- Connect all power supplies to grounded outlets. In each case, ensure that the ground connection is maintained from the outlet socket through to the power supply's AC power input.
- Do not connect the link interface to any other equipment, particularly network or telecommunications equipment.
- Take any required ESD precautions.

Repair

- Do not attempt to open or repair a power supply unit.
- Do not attempt to open or repair the Media- / DVI-Converter. There are no user serviceable parts inside.
- Please contact your dealer or manufacturer if there is a fault.

3 Description

3.1 Application

The Media- / DVI-Converter is used to convert and output video signals of one or more video sources (computer, CPU, camera, DVD player) in the DVI-D format.

The Media- / DVI-Converter can be used as a switch between concurrently available input signals.

The Media- / DVI-Converter can further be used as a scaler, scaling video signals to a specific output format.

3.2 System Overview

The input ports of the Media- / DVI-Converter are connected to the video source(s) (e.g. computer, CPU, camera, DVD player, SPS control), using the provided cables or other suitable video cables.

The DVI-D monitor is connected to the output.

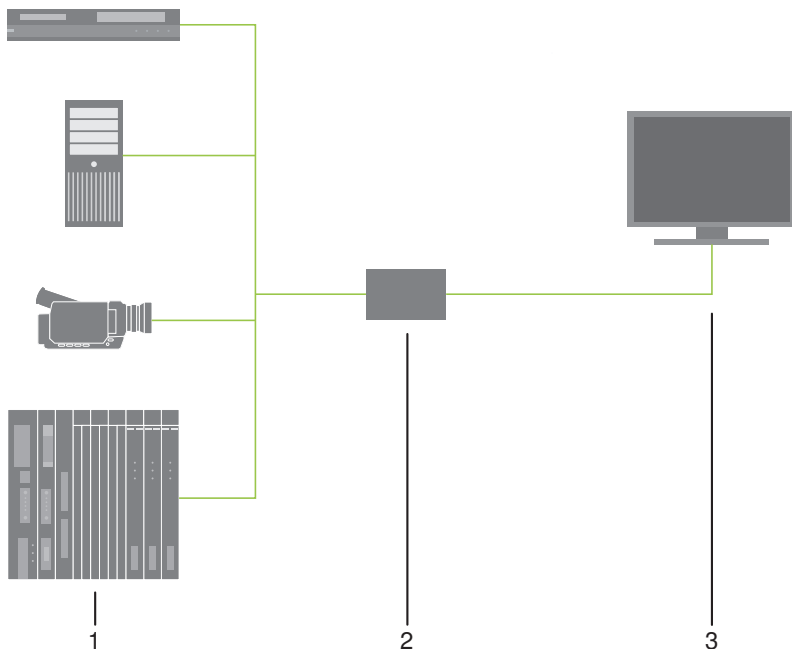

System Overview

- 1 Sources (DVD player, computer, camera, SPS control)
- 2 Media- / DVI-Converter
- 3 Monitor



See Chapter 4.3, Page 19 for installation examples.

3.3 Product Range

Model	Description
TH-C-VGA-DVI	Media- / DVI-Converter for VGA- / DVI-Input (up to 1920x1200)
TH-C-MA-DVI	Media- / DVI-Converter for VGA- / DVI-Input (up to 1920x1200) and Video (Y/C) / Component (YPbPr) / FBAS and CGA / EGA / MDA
TH-C-MA-SDI-DVI	Media- / DVI-Converter for VGA- / DVI-Input (up to 1920x1200) and Video (Y/C) / Component (YPbPr) / FBAS and (HD-)SDI
TH-C-MA-RGB-DVI	Media- / DVI-Converter for RGB- / VGA- / DVI-Input (up to 1920x1200) with a separate 5x BNC RGB-Input



The input side of the following KVM extenders correspond to the Media- / DVI-Converter TH-C-VGA-DVI: TH-E-KIT-xxxx-V, TH-E-L-xxxx-V.

3.4 Upgrade Kits

Model	Description
TH-ACCS-130	19"/1U rack mount kit to mount up to 4 devices of type TH-C-VGA-DVI
TH-ACCS-131	19"/1U rack mount kit to mount up to 4 devices of type TH-C-MA-D, TH-C-MA-SDI-DVI, TH-C-MA-RGB-DVI
TH-ACCS-128	Mounting plate to mount by screws TH-C-VGA-DVI
TH-ACCS-129	Mounting plate to mount by snap on TH-C-VGA-DVI
TH-ACCS-144	Mounting plate to mount by screws TH-C-MA-D, TH-C-MA-SDI-DVI, TH-C-MA-RGB-DVI
TH-ACCS-145	Mounting plate to mount by snap on TH-C-MA-D, TH-C-MA-SDI-DVI, TH-C-MA-RGB-DVI

3.5 Accessories

Model	Description
TH-ACCS-133	Video adapter (BNC connector to Cinch connector)
TH-ACCS-134	RGB cable (2.0 m, 5x BNC connector)
TH-ACCS-135	EGA cable (1.8 m, D-Sub 9 connector)
TH-ACCS-136	Infrared remote control
TH-ACCS-137	Component video cable (1.5 m, 3x RCA connector)
TH-ACCS-138	SDI cable (1.8 m, BNC connector)
TH-ACCS-139	S-Video cable (3.0 m, Mini-DIN connector, 4 pole)
TH-ACCS-140	International power supply unit 100-240VAC / 5VDC / 4 A
TH-ACCS-141	VGA cable (1.8 m, VGA connector to DVI-I connector)
TH-ACCS-142	RGB / DVI cable (0.2 m, 5x BNC connector to DVI-D connector)
TH-ACCS-143	DVI-D cable (1.8 m, DVI-D connector)

3.6 Device Views

3.6.1 Model TH-C-VGA-DVI

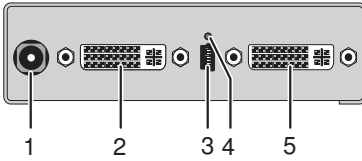

Rear View

- 1 Connect to 5VDC power supply
- 2 Input: DVI-I (VGA)
- 3 Service port
- 4 IR receiver for remote control
- 5 Output: DVI-D

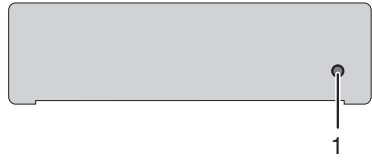

Front View

- 1 IR receiver for remote control

3.6.2 Model TH-C-MA-DVI

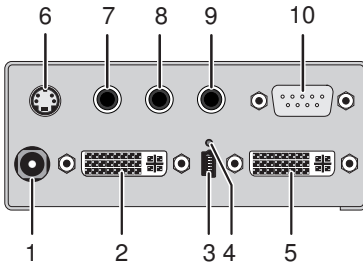

Rear View

- 1 Connect to 5VDC power supply
- 2 Input: DVI-I (VGA)
- 3 Service port
- 4 IR receiver for remote control
- 5 Output: DVI-D
- 6 Input: S-Video (Y/C)
- 7 Input: FBAS 1 or YPbPr (Pr)
- 8 Input: FBAS 2 or YPbPr (Y)
- 9 Input: FBAS 3 or YPbPr (Pb)
- 10 Input: EGA



Front View

- 1 IR receiver for remote control

3.6.3 Model TH-C-MA-SDI-DVI

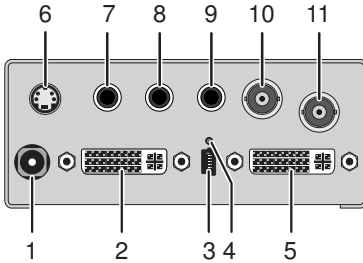

Rear View

- 1 Connect to 5VDC power supply
- 2 Input: DVI-I (VGA)
- 3 Service port
- 4 IR receiver for remote control
- 5 Output: DVI-D
- 6 Input: S-Video (Y/C)
- 7 Input: FBAS 1 or YPbPr (Pr)
- 8 Input: FBAS 2 or YPbPr (Y)
- 9 Input: FBAS 3 or YPbPr (Pb)
- 10 Input: FBAS 4
- 11 Input: (HD-)SDI

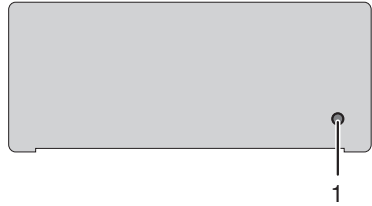

Front View

- 1 IR receiver for remote control

3.6.4 Model TH-C-MA-RGB-DVI

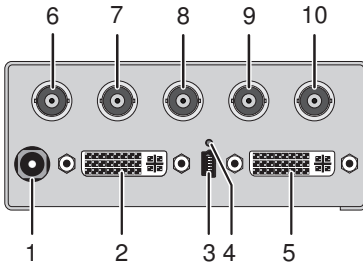

Rear View

- 1 Connect to 5VDC power supply
- 2 Input: DVI-I (VGA)
- 3 Service port
- 4 IR receiver for remote control
- 5 Output: DVI-D
- 6 Input: RGB (red)
- 7 Input: RGB (green)
- 8 Input: RGB (blue)
- 9 Input: RGB (H-/Compos. Sync)
- 10 Input: RGB (V-Sync)



Front View

- 1 IR receiver for remote control

3.7 Status LEDs

The Media- / DVI-Converter is fitted with a multi-color LED for indication of the connection status:

TH-C-VGA-DVI

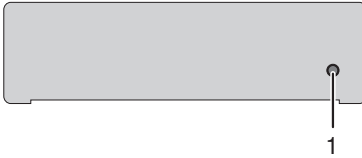

Front View

TH-C-MA -DVI /-SDI-DVI /-RGB-DVI



Front View

LED 1: Connection and Video Status

LED color	Description for the input	Description for the output
Red	No input signal	Monitor detected
Dark Red	Resolution not supported	Monitor not detected
Green	Active video signal	Monitor not detected
Blue	No input signal	Monitor detected
Violet	Resolution not supported	Monitor detected
Turquoise	Active video signal	Monitor detected

4 Installation

4.1 Package Contents

Your Media- / DVI-Converter package contains the following items:

- Media- / DVI-Converter device
- 5VDC international power supply unit
- Country specific power cord
- Quick Setup
- VGA cable (1.8 m, VGA connector to DVI-I connector)

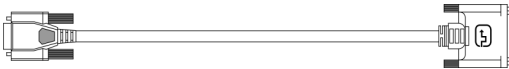

- Infrared remote control

Additional content for TH-C-MA-DVI:

- EGA cable (1.8 m, D-Sub 9 connector)



- Component video cable (1.5 m, 3x RCA connector)



- S-Video (3.0 m, Mini-DIN connector, 4 pole)



Additional content for K238-5VS:

- SDI cable (2.0 m, BNC connector)

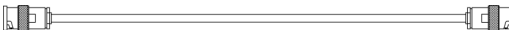

- Component video cable (1.5 m, 3x RCA connector)



- S-Video (3.0 m, Mini-DIN connector, 4 pole)



Additional content for K23 TH-C-MA-RGB-DVI:

- RGB cable (2.0 m, 5x BNC connector).

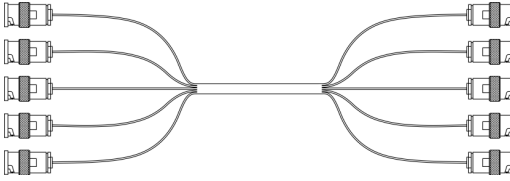

If anything is missing, contact your dealer.

4.2 System Setup



First time users are recommended to setup the system with the CPU Unit and the CON Unit in the same room as a test setup. This will allow you to identify and solve any cabling problems, and experiment with your system more conveniently.



➔ Please verify that interconnect cables, interfaces and handling of the devices comply with the requirements (see Chapter 7, Page 39).

1. Switch off all devices.
2. Connect the monitor to the Media- / DVI-Converter.
3. Connect the source (e.g. computer, video camera or control unit) to the Media- / DVI-Converter with the provided cables. Please ensure the cables are not strained.
4. Connect the provided 5VDC power supply to the Media- / DVI-Converter.
5. Power up the system.



To power up the system, the following sequence is recommended:
Monitor – Media- / DVI-Converter – source.

4.3 Example Applications

This section illustrates typical installations of Media- / DVI-Converters:

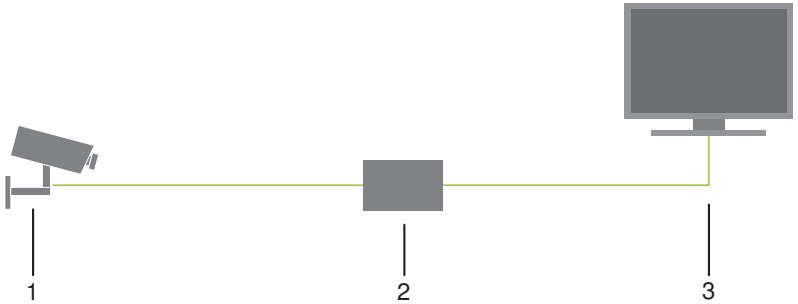

Media- / DVI-Converter (Video Input: Composite)

- 1 Source (observation camera)
- 2 Media- / DVI-Converter
- 3 Monitor

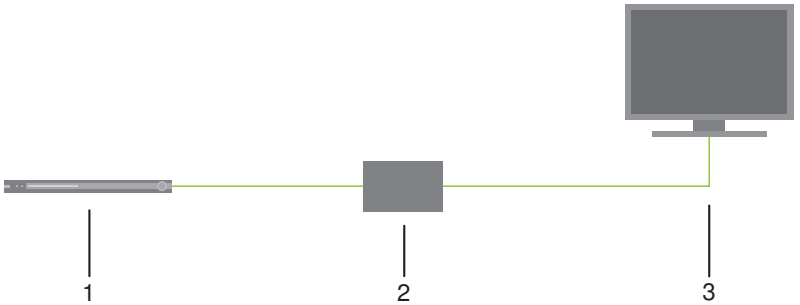

Media- / DVI-Converter (Video Input: S-Video)

- 1 Source (DVD player)
- 2 Media- / DVI-Converter
- 3 Monitor



5 Configuration







5.1 Infrared Remote Control

The Media- / DVI-Converter can be configured by an on screen display (OSD) and by an infrared remote control for the navigation through the menu items of the OSD.



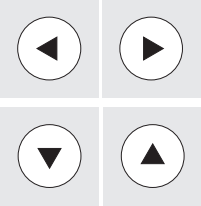

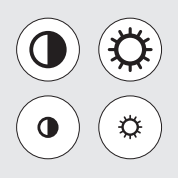
In the OSD, only the navigation keys of the infrared remote control are functional (red function key, key <↵>, key <EXIT>, key <ESC> and cursor keys <◀>, <▶>, <▲>, <▼>).

Button	Description
	Open OSD or select menu.
	Open OSD or select menu.

Button	Description
	Leave OSD.
	Leave current menu and open upper menu level.
	Navigate inside the OSD. Select parameters with cursor keys <◀> and <▶>.
	Read and use DDC of the connected monitor.
	Adjust picture contrast / brightness.
	Reset the Media- / DVI-Converter to factory default.
	Reset picture contrast / brightness to factory default.

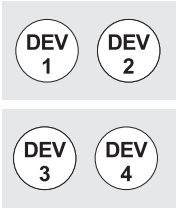
THOR-C Media- / DVI-Converters

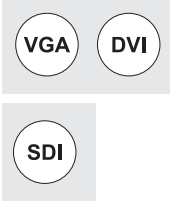
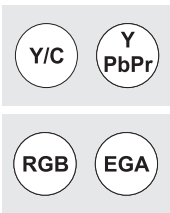
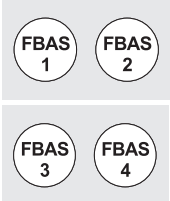
Button	Description
 <p>Buttons labeled DEV 1, DEV 2, DEV 3, and DEV 4 are arranged in two rows of two.</p>	<p>If more than one converter is used: Select a single device for OSD access.</p>
 <p>Button labeled DEV ALL.</p>	<p>If more than one converter is used: Select all devices for OSD access.</p>
 <p>Buttons labeled VGA, DVI, and SDI are arranged in two rows: the first row has VGA and DVI, and the second row has SDI.</p>	<p>Select input signal: VGA, DVI or SDI.</p>
 <p>Buttons labeled Y/C, Y PbPr, RGB, and EGA are arranged in two rows of two.</p>	<p>Select input signal:</p> <ul style="list-style-type: none"> • Y/C (S-Video) • YPbPr (Component Video) • RGB • EGA
 <p>Buttons labeled FBAS 1, FBAS 2, FBAS 3, and FBAS 4 are arranged in two rows of two.</p>	<p>Select input signal FBAS 1–3 (Cinch) or FBAS 4 (BNC).</p>

5.2 On Screen Display (OSD)

All settings of the Media- / DVI-Converter can be adjusted via the on screen display (OSD).

General Structure of the OSD:

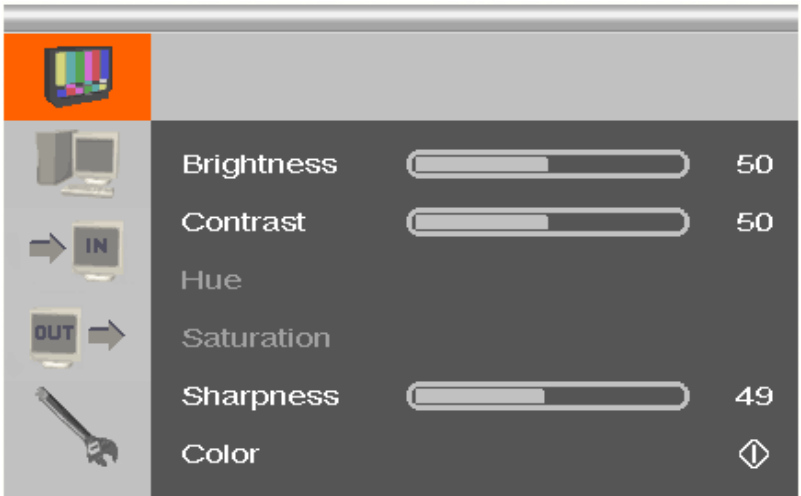

The left column shows the range of the main menu, the right column shows the current submenus with the respective configuration options.

The various configuration and setting options of the Media- / DVI-Converter are described below:

5.2.1 Main Menu Item 'Color Settings'

This menu offers color specific settings and configurations for the Media- / DVI-Converter.

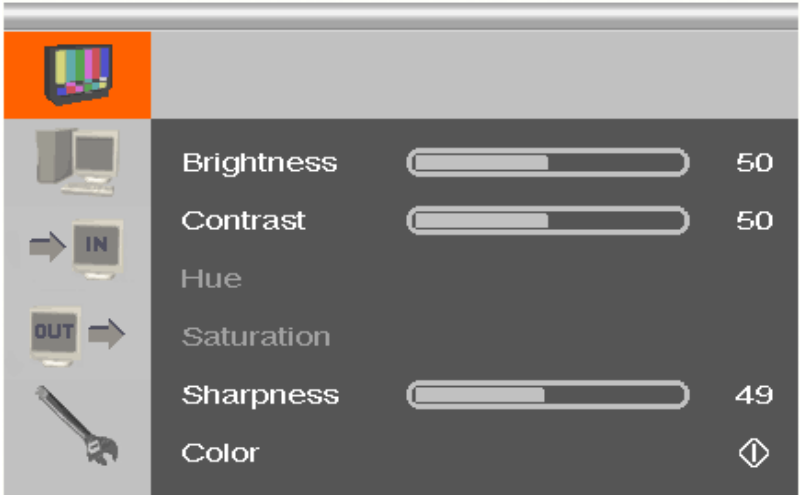

Menu View 'Color Settings'

Menu Item	Description
Brightness	Adjust brightness of the picture
Contrast	Adjust contrast of the picture
Hue	Change and adjust hue of the picture (only selectable in case of video input signals).
Saturation	Adjust saturation of the picture (only selectable in case of video input signals).
Sharpness	Adjust sharpness of the picture
Color	Open submenu 'Color' (see Chapter 5.2.1.1, Page 25).

5.2.1.1 Submenu 'Color'

This submenu offers advanced color settings for the picture (VGA / RGB / EGA input only).

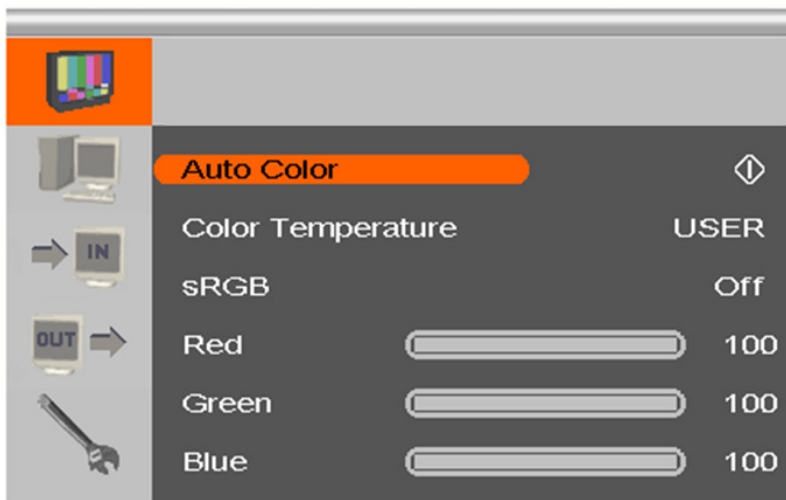

Menu View 'Color'

Menu Item	Description
Auto Color	Adjust color values automatically
Color Temperature	Adjust color temperature of the picture
sRGB	Activate the use of the standard RGB color range (Color optimization for tube monitors).
Red	Adjust red color range
Green	Adjust green color range
Blue	Adjust blue color range

5.2.2 Main Menu Item 'Picture Settings'

This menu offers specific picture settings at the Media- / DVI-Converter.

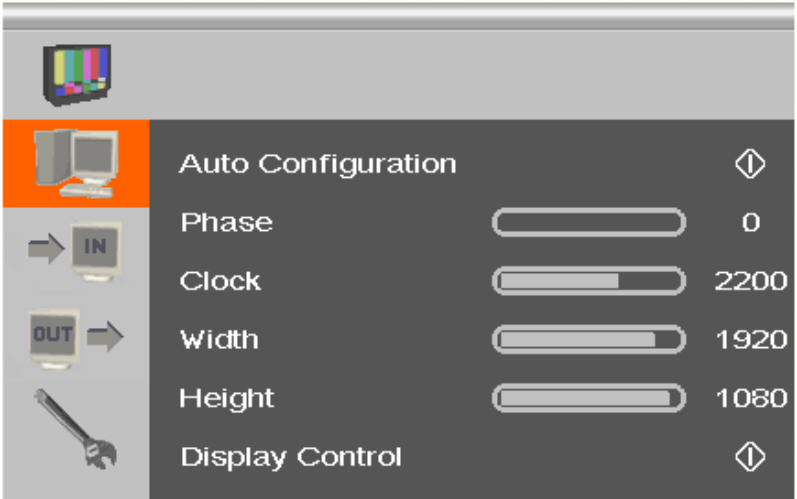

Menu View 'Picture Settings'

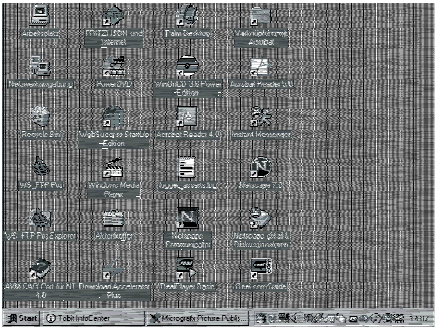
Menu Item	Description
Auto Configuration	Configure picture settings automatically (VGA / RGB / EGA input only).
Phase	Adjust pixel phase i.e. the best position for the analog / digital conversion within one pixel (VGA / RGB / EGA input only).  <i>Example for a wrong pixel phase</i>

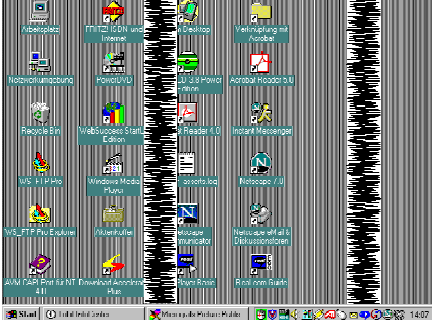
Menu Item	Description
Clock	<p>Adjust pixel clock. The pixel clock shows the maximum number of the pixels that are horizontally displayable. Even non-visible and inactive pixels are counted in (VGA / RGB / EGA input only).</p>  <p><i>Example for a wrong pixel clock.</i></p>
Width	Adjust width of the picture with the number of pixels.
Height	Adjust height of the picture with the number of pixels.
Display Control	Open submenu 'Display Control' (see Chapter 5.2.2.1, Page 28).

5.2.2.1 Submenu 'Display Control'

This submenu offers control options for the display of the picture.

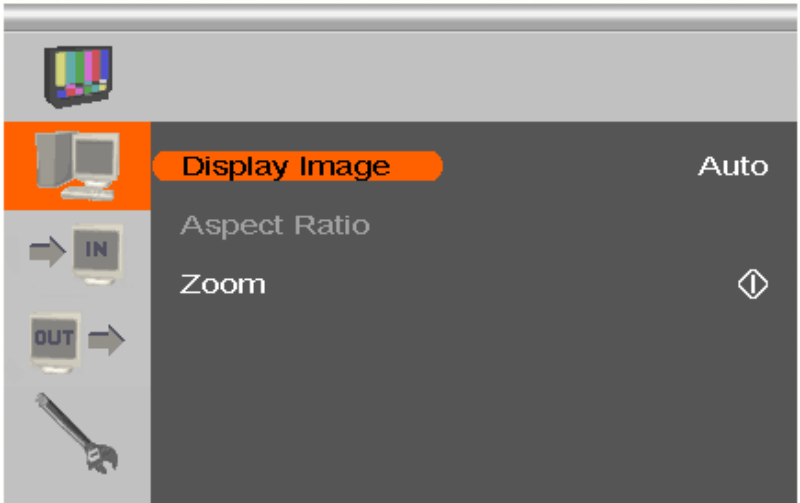

Menu View 'Display Control'

Menu Item	Description
Display Image	Select display option: <ul style="list-style-type: none">'Auto': Scale picture automatically to the maximum value'Aspect': Adjust aspect ratio manually'1:1': Show picture in original size with a black border
Aspect Ratio	Select aspect ratio: 'Auto', '4:3', '14:9', '16:9' or '>16:9' (only if 'Display Image' is set to 'Aspect Ratio').
Zoom	Zoom picture and determine position of enlargement.

5.2.3 Main Menu Item 'Input Settings'

This menu offers specific settings for the input of the Media- / DVI-Converter.

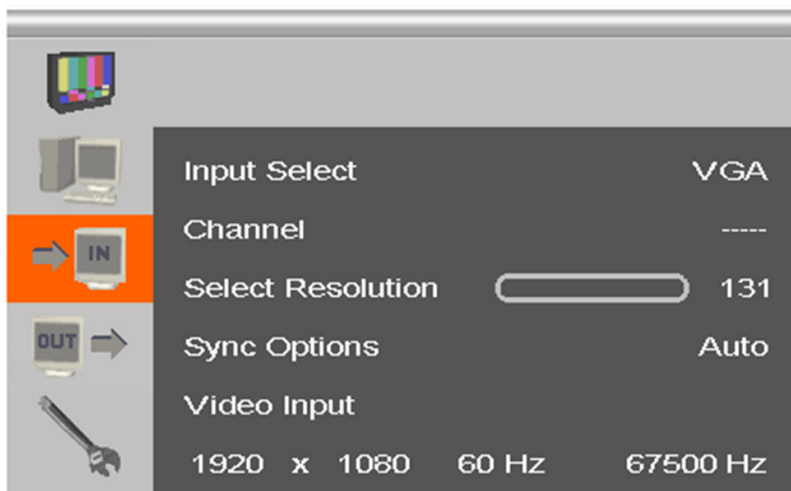

Menu View 'Input Settings'

Menu Item	Description
Input Select	Select input signal
Channel	<ul style="list-style-type: none"> For FBAS input signal: Select Composite channel. For EGA input: Select EGA, CGA or MDA input signal.
Select Resolution	<p>Select video mode compatible to input signal (see Chapter 7.2, Page 41 for supported video modes).</p> <p>Save settings by leaving the menu (monitor goes blank for a short time).</p>
Sync Options	<p>Select type of synchronization of the RGB signal. The type depends from the incoming RGB signal.</p> <ul style="list-style-type: none"> 'Auto': Automatic adjustment 'Composite (CS)' or 'Sync On Green (SOG)': Manual adjustment in case of picture failures (VGA / RGB input only)
Video Input	Display of selected video mode

5.2.4 Main Menu Item 'Output Settings'

This menu offers specific settings for the output of the Media- / DVI-Converter.



Menu View 'Output Settings'

Menu Item	Description
Output	Select output resolution: <ul style="list-style-type: none"> 'DDC': Use preferred resolution of the monitor's DDC at the output 'Select': Select from predefined output resolutions in the menu item 'Resolution' '1:1': Use input resolution as output resolution
Resolution	If 'Output' is set to 'Select': Select from predefined output resolutions. A higher resolution can be selected at any time. If you select a lower resolution, the number of output pixels needs to comply with the following rule: <ul style="list-style-type: none"> Horizontally: At least 50% Vertically: At least 33%
Display Position	Adjust position of picture manually
Video Output	Display of the selected output resolution



For the scaling of the 1920x1200 resolution, restrictions apply.

5.2.5 Main Menu Item 'General Settings'

This menu offers general settings for the Media- / DVI-Converter.

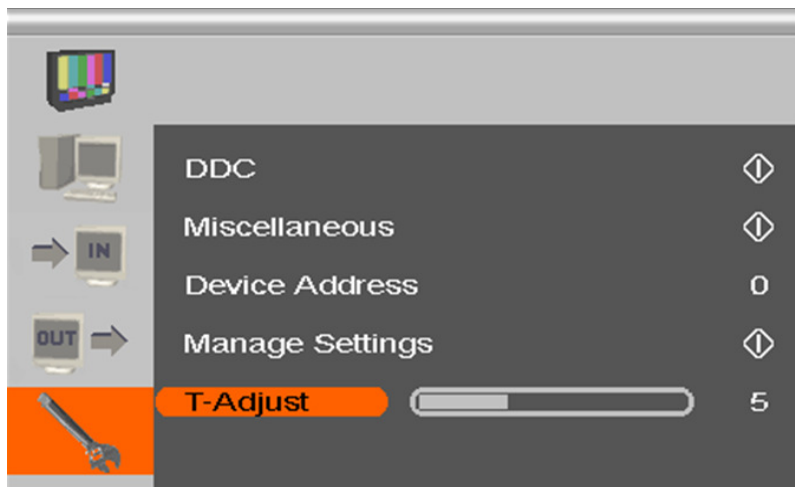

Menu View 'General Settings'

Menu Item	Description
DDC	Open submenu 'DDC' (see Chapter 5.2.5.1, Page 32).
Miscellaneous	Open submenu 'Miscellaneous' (see Chapter 5.2.5.2, Page 33).
Device Address	Assign device ID. The device ID clearly identifies the device for the infrared remote control so that settings can be made for a specific device only.
Manage Settings	Write the existing device settings on the internal memory of the Media- / DVI-Converter ('Save'). These settings can be loaded again if required ('Load'), e.g. after a firmware update.
T-Adjust	Compensate picture failures due to device temperature



Save device settings if you have made extensive settings or if you want to do a firmware update.

5.2.5.1 Submenu 'DDC'

This submenu offers DDC specific settings. DDC information is relevant for the output settings and for the connection to a computer or CPU.

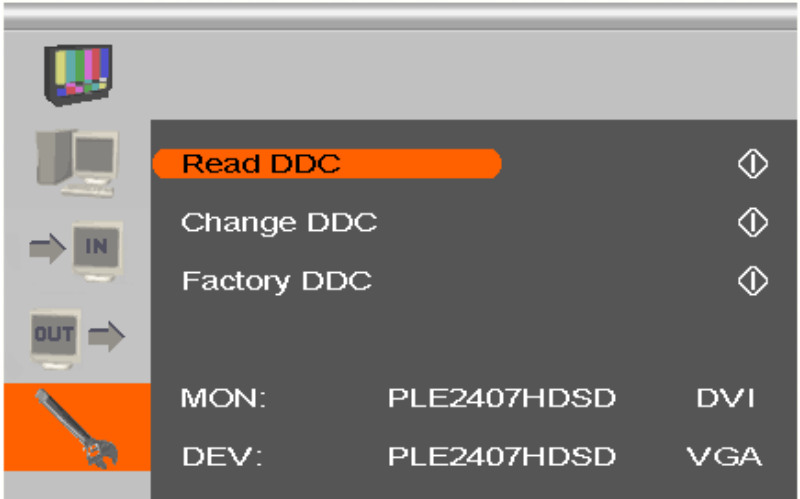

Menu View 'DDC'

Menu Item	Description
Read DDC	Use the monitor DDC as the device DDC and save it as DVI or VGA DDC.
Change DDC	Save the device DDC as DVI or VGA DDC
Factory DDC	Use default DDC 'VGA2DVI' as device DDC
MON:	Display of name and type of the monitor DDC
DEV:	Display of name and type of the device's DDC that is provided at the DVI-I input by the Media- / DVI-Converter.



When saving the DDC as DVI or VGA DDC, the selected type of DDC must match the video signal of the source (VGA or DVI) (see Chapter 5.2.3, Page 29: Menu item 'Input Select').

5.2.5.2 Submenu 'Miscellaneous'

This submenu offers various device specific settings.

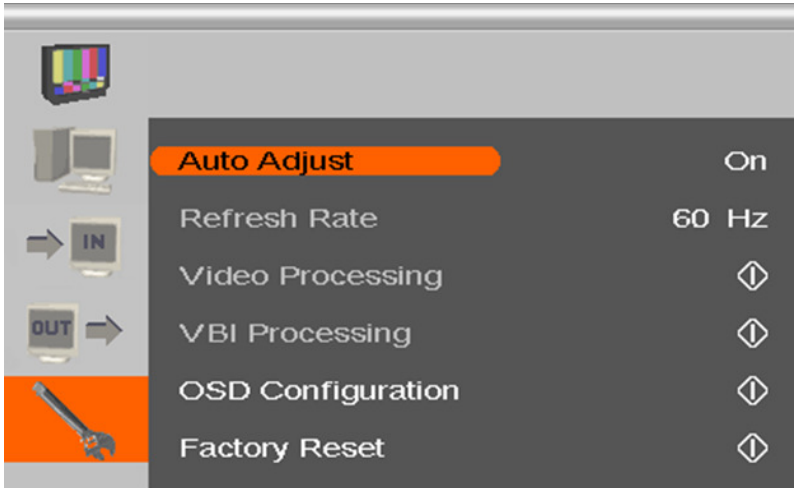

Menu View 'Miscellaneous'

Menu Item	Description
Auto Adjust	Activate or deactivate the automatic configuration of the picture settings after changing the video mode.
Refresh Rate	Change refresh rate if output is set to 'DDC'.
Video Processing	Not used
VBI Processing	Not used
OSD Configuration	Configure OSD display on screen.
Factory Reset	Reset device to factory default (confirmation dialog)

Submenu 'OSD Configuration'

This submenu offers various settings for the OSD display.

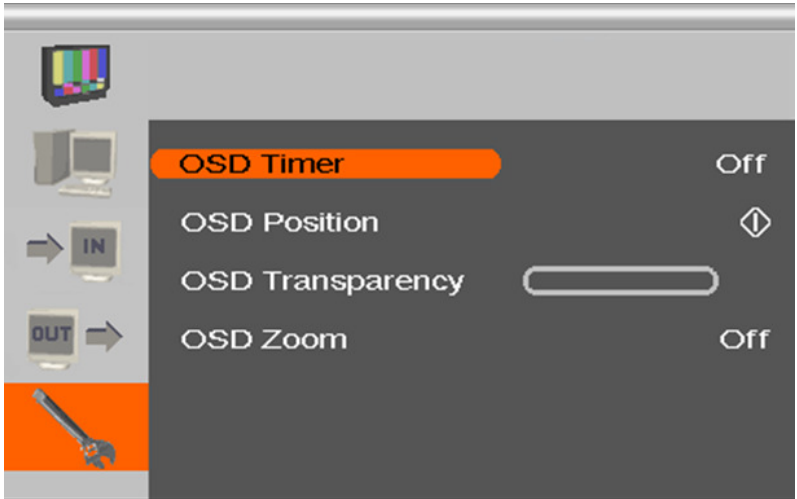

Menu View 'OSD Configuration'

Menu Item	Description
OSD Timer	Activate and select time of inactivity after which OSD is closed automatically.
OSD Position	Adjust vertical and horizontal OSD position on screen.
OSD Transparency	Adjust OSD transparency
OSD Zoom	Activate scaling of OSD display

Menu Item	Description
OSD Timer	Activate and select time of inactivity after which OSD is closed automatically.
OSD Position	Adjust vertical and horizontal OSD position on screen.
OSD Transparency	Adjust OSD transparency
OSD Zoom	Activate scaling of OSD display

6 Operation

6.1 Optimization of Picture Settings

All common video modes are pre-installed in an internal table of the Media- / DVI-Converter. If the input signal corresponds to one of these video modes, the signal will be automatically detected and the picture will be displayed.

If picture quality is not satisfying or no picture is displayed, proceed as follows:

1. Optimize the output settings (see Chapter 6.1.1, Page 36). Thus, the picture display will be adapted to the properties of the monitor.
2. Optimize the input settings (see Chapter 6.1.2, Page 36). Check if the automatically detected video mode corresponds to your input signal. Alternatively, you can manually select the most suitable video mode, even if you have an unknown input signal.
3. Optimize the picture settings for your input signal (see Chapter 6.1.3, Page 37).



In some cases it might happen that none of these measurements leads to a satisfying result. In this case please contact your dealer or manufacturer.

6.1.1 Optimization of Output Settings

1. If you have an analog input signal, display a picture with as much detail as possible on your graphic source, e.g. a text with black letters on a white ground (or vice versa).
2. Open the OSD with the infrared remote control.
3. Select 'Output Settings' in the main menu (see Chapter 5.2.4, Page 30).
4. Select the output resolution in the menu item 'Output':
 - Select 'DDC' to use the preferred resolution of the monitor DDC.
 - If the preferred resolution of the device DDC does not result in a satisfying picture, select 'Factory' and from the menu item 'Resolution' the most suitable resolution for the monitor.
5. Exit the OSD.

A window appears to save settings. This may take a few seconds.
6. Save the settings.

6.1.2 Optimization of Input Settings

For certain analog input signals (VGA / RGB / EGA), if the picture quality is not satisfying or no picture is displayed, you can select a video mode depending on the input signal.

1. Open the OSD with the infrared remote control.
2. Select 'Input Settings' in the main menu (see Chapter 5.2.3, Page 29).
3. Test the recommended resolutions that are listed in the menu item 'Select Resolution'. The menu item is inactive, if there is only one recommended resolution.
4. Run the automatic picture adjustment:
 - Select 'Picture Settings' in the main menu (see Chapter 5.2.2, Page 26).
 - Select the menu item 'Auto Configuration'. Thereby picture size might change.
5. Check the test picture: If the vertical lines are displayed clearly, without smear or tremble, the setting has been successful.
6. Exit the OSD.

A window appears to save settings. This can take a few seconds.
7. Save the settings.

6.1.3 Optimization of Picture Settings

For certain analog input signals (VGA / RGB / EGA), if the picture quality is still not satisfying after the automatic picture adjustment, you can adjust clock and phase manually.

1. Select 'Picture Settings' in the main menu.
2. Modify the values in the menu items 'Clock' and 'Phase' until all failures have disappeared.
3. If the picture is displaced:
 - Select the menu item 'Display position' in the main menu item 'Output Settings' and position the picture in the upper left corner of the monitor.
 - Select the menu items 'Width' and 'Height' in the main menu item 'Picture Settings' and modify the values for width and height of the picture until the monitor is completely filled by the picture.
4. Exit the OSD.

A window appears to save settings. This can take a few seconds.
5. Save the settings.

6.2 Download of DDC Information

Loading DDC information is only relevant if you want to connect a DVI or VGA source. By default, the factory DDC information is reported to the source (computer, CPU). If these settings do not lead to a satisfying result, the DDC information of the connected monitor can be downloaded and stored internally.

There are two options to load the DDC information of the connected monitor:

- By means of the infrared remote control (see Chapter 6.2.1, Page 38).
- By means of the 'Read DDC' command in the OSD (see Chapter 6.2.2, Page 38).

6.2.1 Download of DDC by Infrared Remote Control

1. Press the <DDC> button on your infrared remote control.
2. Save the DDC as DVI or VGA DDC matching the input video signal.
The DDC information of the connected monitor is saved in the Media- / DVI-Converter in the selected format.
The source (computer, CPU) can read the DDC information of the monitor and display the available video resolutions.

6.2.2 Download of DDC via OSD

1. Open the OSD with the infrared remote control.
2. Select 'General Settings' in the main menu (see Chapter 5.2.5, Page 31).
3. Select the menu item 'Read DDC' in the submenu 'DDC'.
4. Save the DDC as DVI or VGA DDC matching the input video signal.
The DDC information of the connected monitor is saved in the Media- / DVI-Converter in the selected format and is displayed at the bottom of the OSD menu under 'DEV:'.
The source (computer, CPU) can read the DDC information of the monitor and display the available video resolutions.

7 Specifications

7.1 Interfaces

7.1.1 DVI-D Single Link

The video interface supports the DVI-D protocol. All signals that comply to DVI-D Single Link norm can be transmitted. This includes e.g. monitor resolutions such as 1920x1200@60Hz, Full HD (1080p) or 2K HD (up to 2048x1152). Data rate is limited to 165 MPixel/s.

7.1.2 DVI-I Single Link

The video interface supports the DVI-I protocol. All analog (VGA) or digital (DVI) signals that comply to DVI-I Single Link norm can be transmitted. This includes e.g. monitor resolutions such as 1920x1200@60Hz, Full HD (1080p) or 2K HD (up to 2048x1152). Data rate is limited to 165 MPixel/s.



Transmission of interlaced video signals, such as 1920x1080i, cannot be guaranteed.

7.1.3 S-Video (Y/C)

The transmission of the video signal consists of a separate transmission of brightness and color information by two isolated signal and ground wire pairs. The plug connection consists of a 4-pole Mini-DIN connector with an input impedance of 75 Ω .

7.1.4 SDI Video

The (HD-)SDI video signal is transmitted by a serial digital interface. The transmission is carried out uncoded and uncompressed via a coaxial cable. The voltage level of video signal is 0.8 Vpp.

7.1.5 EGA (D-Sub 9)

The voltage level is a 5V TTL level.

The transmission of the video signal is carried out via a 9-pole D-Sub connector.

7.1.6 Composite Video (BAS / FBAS)

The (F)BAS signal is transmitted in an unmodulated form and consists of a brightness and synchronization signal, in case of FBAS also of an extra color signal.

The transmission of the analog video signal is carried out via a RCA (Cinch) or BNC (bayonet) plug connection.

7.1.7 Component Video (YPbPr)

The transmission of the analog video signals is carried out via three RCA connectors, whereby the first connector (Pr) transmits the color spectrum of the red and turquoise color range. The second connector (Y) transmits brightness and synchronization and the third connector (Pb) transmits the yellow and blue color range.

7.1.8 RGB Video

The video signal consists of R (red), G (green) and B (blue) signals. The voltage level of the video signal is 0.7 Vpp. The green signal can additionally contain the (Composite) synchronization signal. Furthermore, the interface is able to support RGBs and RGBHV video signals.

The communication of the video interface is carried out via a coaxial plug connection with a 5x bayonet lock (BNC).

7.2 Supported Video Modes

The following table lists the video modes that are recognized by the Media- / DVI-Converter (see Chapter 5.2.3, Page 29).



Video modes in italics will be recognized but not or not properly displayed.

Video modes for DVI, VGA, EGA and RGB

Index	Description	Hres	Vres	V-Freq	H-Freq	Dot Clk
17	CGA(TTL)	320	200	59,9	15,7	7,2
10	PAL	416	574	50,0	15,6	8,0
36	MONA S5	442	416	54,4	24,3	14,0
4	AS 230 / 235 / OS 252	448	288	50,0	15,6	10,0
5	GBE 3977-64x32	448	288	50,0	15,6	10,0
18	DCC 555a	504	280	50,2	15,7	10,0
15	WF470	512	240	49,1	15,6	12,0
6	WF470	512	245	50,0	15,6	12,0
7	WF470 / AS215	512	256	50,0	15,6	12,0
60	WF470 / AS215	512	512	50,1	31,3	24,0
12	GEM 80 graph i	560	224	25,0	15,6	11,7
24	GEM 80 graph i	560	224	30,1	15,8	11,9
28	GEM 80 graph i	560	224	37,5	18,2	12,0
45	<i>750b</i>	<i>560</i>	<i>248</i>	<i>41,6</i>	<i>26,0</i>	<i>20,0</i>
8	GBE3977 - 80x48	560	288	50,0	15,6	13,0
9	DISET - 80x25	560	288	50,0	15,6	12,2
19	DCS 560	560	288	50,0	15,7	11,4
44	MONA -C	560	413	58,2	25,8	20,0
61	GEM 80 graph progr.	560	448	50,1	31,3	23,5
64	GEM 80 graph progr.	560	448	60,0	31,5	23,7
79	GEM 80 graph progr.	560	448	75,1	36,4	24,0

THOR-C Media- / DVI-Converters

Index	Description	Hres	Vres	V-Freq	H-Freq	Dot Clk
53	WF480	580	480	59,9	30,6	25,0
22	CGA(TTL)	640	200	59,9	15,7	14,3
3	CP526/527	640	234	50,0	15,4	13,1
16	GEM 80 text	640	288	48,8	15,6	13,0
47	Prokon 2	640	288	83,0	27,4	23,0
34	EGA (TTL)	640	350	59,8	21,9	16,3
162	VGA	640	350	70,2	31,5	25,2
166	VGA	640	350	84,9	37,8	31,4
33	IVE 3	640	379	50,1	21,8	17,4
30	IVE4	640	385	50,0	20,0	16,1
32	Custom 1	640	385	49,9	20,6	16,5
39	<i>ABB MOD 300</i>	<i>640</i>	<i>385</i>	<i>60,0</i>	<i>24,8</i>	<i>19,8</i>
35	IVE 2	640	398	50,0	21,9	17,8
52	NEC 3D PGC	640	398	59,6	30,3	25,0
70	XGA2	640	398	77,4	39,3	32,4
37	VGA	640	400	55,9	24,6	20,9
49	OP 398 K	640	400	60,0	27,5	22,2
164	VGA	640	400	70,2	31,5	25,2
168	VGA	640	400	84,9	37,8	31,4
38	COROS LS-C	640	405	59,1	25,4	21,7
40	COROS LS-C	640	405	59,1	25,4	21,7
42	Prokon 1	640	432	53,8	25,5	23,1
48	Prokon 3	640	432	58,9	27,4	23,0
56	CP526 highres.	640	468	60,0	30,9	26,2
57	CP528 highres	640	468	60,0	30,9	28,3
59	CP526 highres	640	468	50,0	31,2	26,2

THOR-C Media- / DVI-Converters

Index	Description	Hres	Vres	V-Freq	H-Freq	Dot Clk
54	WF480 / Gracis	640	480	59,9	30,6	27,6
55	DAMATIC	640	480	59,2	30,8	25,9
63	VESA Standard	640	480	60,0	31,5	25,2
74	MAC Mode	640	480	66,7	35,0	31,4
75	MAC Mode	640	480	66,9	35,1	30,3
81	VESA Standard	640	480	75,0	37,5	31,5
83	VESA Standard	640	480	72,7	37,8	31,4
85	VESA Standard	640	480	72,9	37,9	31,5
87	VESA Standard	640	480	84,9	43,2	35,9
1	NEC 15kHz	642	200	60,0	15,0	13,5
2	NEC 15kHz i	642	200	30,0	15,0	13,5
65	Std.-VGA	656	496	60,0	31,5	25,2
86	NEC 42.5kHz	677	550	70,0	42,5	37,4
20	NTSC (halfline)	680	240	59,9	15,7	12,9
23	NTSC	680	480	59,9	15,7	12,9
25	NTSC Interlaced	720	240	30,1	15,8	13,6
11	PAL Interlaced	720	288	25,0	15,6	13,5
27	<i>ABB DSAV110</i>	<i>720</i>	<i>336</i>	<i>50,1</i>	<i>17,9</i>	<i>15,6</i>
29	Hercules Monochrom	720	350	49,7	18,4	16,2
72	XGA2	720	350	87,8	39,4	35,5
163	VGA	720	350	70,2	31,5	28,4
167	VGA	720	350	84,9	37,8	35,4
31	Custom 2	720	400	49,9	20,6	18,5
46	NEC 27kHz	720	400	55,0	27,0	24,3
73	XGA2	720	400	87,8	39,4	35,5
165	VGA	720	400	70,2	31,5	28,4

THOR-C Media- / DVI-Converters

Index	Description	Hres	Vres	V-Freq	H-Freq	Dot Clk
169	VGA	720	400	85,0	37,9	35,5
41	VDU 2000 Coros	720	405	59,1	25,4	24,5
43	Teleperm / DS 078	720	408	60,0	25,7	23,1
66	NTSC Progressive	720	480	60,0	31,5	27,0
71	XGA2	720	480	74,9	39,3	35,4
62	PC -Textmode	738	414	70,2	31,5	28,4
21	MTBI	746	246	59,9	15,7	14,1
68	GTF	768	576	60,0	35,8	34,9
88	GTF	768	576	71,9	43,2	42,9
91	GTF	768	576	74,9	45,1	45,5
104	GTF	768	576	85,0	51,4	51,8
89	NEC 44kHz	770	549	72,2	44,0	44,0
58	CP 527/60	800	468	60,0	30,9	32,8
76	VG900601	800	600	56,2	35,1	35,9
84	VG900602	800	600	60,2	37,8	39,9
92	VESA 600	800	600	74,9	46,8	49,4
96	VS900603	800	600	72,1	48,0	49,9
106	VESA Standard	800	600	84,9	53,6	56,2
100	MAC Mode	832	624	75,0	49,5	55,4
101	MAC Mode	832	624	74,5	49,7	57,3
80	VESA Standard	960	600	60,1	37,4	46,0
77	768i	1024	384	43,0	35,5	44,9
78	768p	1024	768	86,8	35,5	44,9
98	VG901101	1024	768	59,9	48,3	64,9
99	MAC Mode	1024	768	59,9	48,7	63,9
112	VS910801	1024	768	70,0	56,4	74,9

THOR-C Media- / DVI-Converters

Index	Description	Hres	Vres	V-Freq	H-Freq	Dot Clk
113	IBM	1024	768	72,1	57,5	75,0
114	SUN Mode	1024	768	72,0	58,0	75,2
116	VESA Standard	1024	768	75,0	60,0	78,7
117	VESA Standard	1024	768	74,9	60,2	79,9
133	VESA Standard	1024	768	84,9	68,6	94,4
108	Custom Corus Group	1024	864	60,0	54,3	73,0
69	VESA Standard	1088	612	60,3	38,2	53,2
13	DISET oversample	1120	288	50,0	15,6	24,5
107	VESA Standard	1152	864	60,0	53,7	81,6
121	DMT1185	1152	864	70,0	63,5	100,1
122	VESA Standard	1152	864	70,0	63,8	94,4
130	VESA Standard	1152	864	75,0	67,5	108,0
146	GTF	1152	864	86,1	77,1	119,7
134	Apple Mac II 2	1152	870	75,1	68,7	100,0
118	SUN Mode	1152	900	66,0	61,8	94,4
119	SUN Mode	1152	900	66,7	62,5	95,5
137	NOKIA 447X	1152	900	76,0	71,7	105,5
14	GBE3977 Oversample	1164	288	50,0	15,6	26,0
50	<i>1280i</i>	<i>1280</i>	<i>512</i>	<i>25,0</i>	<i>28,0</i>	<i>44,6</i>
82	VESA CVT 16:9	1280	720	50,0	37,5	74,3
90	VESA CVT 16:9	1280	720	59,9	44,8	74,5
94	TV Mode	1280	768	60,0	47,7	80,1
97	TV Mode	1280	768	60,0	48,1	81,2
102	Beamer 16:10	1280	800	59,8	49,7	83,5
115	VESA Standard	1280	960	60,0	60,0	108,0
139	GTF	1280	960	72,0	72,1	124,6

THOR-C Media- / DVI-Converters

Index	Description	Hres	Vres	V-Freq	H-Freq	Dot Clk
143	DMT 127A	1280	960	75,0	75,0	126,0
148	GTF	1280	960	77,3	77,5	133,9
156	VESA Standard	1280	960	85,0	85,9	148,4
105	TV Mode	1280	1024	50,1	53,4	90,1
120	SONY GDM2036s	1280	1024	59,9	63,3	108,1
124	VESA Standard	1280	1024	59,9	63,9	107,9
125	Siemens SMI-5	1280	1024	60,0	64,0	112,6
135	VESA Standard	1280	1024	67,0	70,7	119,9
138	SUN Mode	1280	1024	66,7	71,7	117,0
147	SXGA Unix	1280	1024	73,0	77,2	130,9
149	HP Workstation B123L	1280	1024	72,0	78,1	135,0
151	VESA Standard	1280	1024	75,0	79,9	134,9
158	VESA Standard	1280	1024	85,0	91,1	157,4
93	TV Mode 16:9	1360	765	60,1	47,6	84,5
95	Plasma TV 16:9	1360	768	60,0	47,7	85,5
127	NVIDIA 4:3	1400	1050	59,7	65,0	121,2
150	GTF	1400	1050	72,0	78,8	149,4
153	GTF	1400	1050	75,0	82,2	155,9
26	<i>NTSC</i>	<i>1440</i>	<i>240</i>	<i>30,0</i>	<i>15,8</i>	<i>27,1</i>
109	TV Mode 16:10	1440	900	60,0	55,6	89,0
103	1200i	1600	600	40,0	50,0	108,0
110	TV Mode 16:9	1600	900	59,9	55,8	118,7
123	VESA Standard	1600	1024	60,2	63,8	136,8
142	VESA Standard	1600	1200	60,0	75,0	162,0
144	UXGA	1600	1200	50,1	75,0	138,0
145	UXGA rb	1600	1200	60,3	75,4	140,5

THOR-C Media- / DVI-Converters

Index	Description	Hres	Vres	V-Freq	H-Freq	Dot Clk
152	VESA Standard	1600	1200	65,0	81,3	175,6
157	VESA Standard	1600	1200	70,0	87,5	189,0
159	VESA Standard	1600	1200	75,0	93,2	164,0
160	VESA Standard	1600	1200	75,0	93,8	202,6
126	WSXGA+ 16:10	1680	1050	59,9	64,7	119,0
128	WSXGA+	1680	1050	60,1	65,4	146,5
154	WSXGA+	1680	1050	74,9	82,3	187,0
161	WSXGA+	1680	1050	85,0	93,9	214,8
155	VESA Standard	1792	1344	60,0	83,6	204,7
51	<i>1080i</i>	<i>1920</i>	<i>540</i>	<i>25,0</i>	<i>28,1</i>	<i>74,2</i>
67	<i>1080i@60Hz</i>	<i>1920</i>	<i>540</i>	<i>30,0</i>	<i>33,8</i>	<i>74,4</i>
111	1080p	1920	1080	49,7	55,9	147,6
129	1080p	1920	1080	59,7	66,8	172,1
131	1080p	1920	1080	60,0	67,5	148,5
140	WUXGA	1920	1200	59,9	74,0	153,9
141	WUXGA	1920	1200	59,6	74,2	192,3
132	2048*1080@60Hz	2048	1080	60,0	67,5	148,5
136	2048*1152@60Hz	2048	1152	59,9	71,0	156,8

THOR-C Media- / DVI-Converters

Video modes for Component- / Composite-Video, S-Video and SDI

Description	FBAS	S-Video	Component	(HD-)SDI
480i / 60Hz	X	X	X	X
576i / 50Hz	X	X	X	X
480p / 60Hz	–	–	X	–
576p / 50Hz	–	–	X	–
720p / 50Hz	–	–	X	X
1080p	–	–	–	–

7.3 Connector Pinouts

Connector DVI-D Single-Link

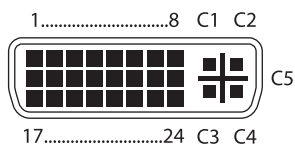

Pin	Signal	Pin	Signal	Pin	Signal
1	T.M.D.S data 2-	9	T.M.D.S data 1-	17	T.M.D.S data 0-
2	T.M.D.S data 2+	10	T.M.D.S data 1+	18	T.M.D.S data 0+
3	T.M.D.S data 2 GND	11	T.M.D.S data 1 GND	19	T.M.D.S data 0 GND
4	n.c.	12	n.c.	20	n.c.
5	n.c.	13	n.c.	21	n.c.
6	DDC Input (SCL)	14	+5VDC high impedance	22	T.M.D.S clock GND
7	DDC Output (SDA)	15	GND	23	T.M.D.S clock +
8	Internal use	16	Hot Plug recognition	24	T.M.D.S clock -
C1	Internal use			C3	Internal use
C2	n.c.	C5	GND	C4	Internal use

Connector DVI-I Single-Link

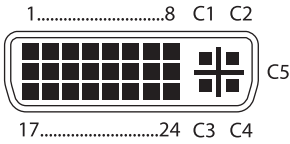

Pin	Signal	Pin	Signal	Pin	Signal
1	T.M.D.S data 2-	9	T.M.D.S data 1-	17	T.M.D.S data 0-
2	T.M.D.S data 2+	10	T.M.D.S data 1+	18	T.M.D.S data 0+
3	T.M.D.S data 2 GND	11	T.M.D.S data 1 GND	19	T.M.D.S data 0 GND
4	n.c.	12	n.c.	20	n.c.
5	n.c.	13	n.c.	21	n.c.
6	DDC Input (SCL)	14	+5VDC high impedance	22	T.M.D.S clock GND
7	DDC Output (SDA)	15	GND	23	T.M.D.S clock +
8	Internal use	16	Hot Plug recognition	24	T.M.D.S clock -
C1	Internal use			C3	Internal use
C2	n.c.	C5	GND	C4	Internal use

RCA (Cinch)

Picture	Pin	Signal
	1	GND
	2	Data IN / OUT

BNC (SDI, RGB)

Picture	Pin	Signal
	1	Data IN
	2	GND

Mini-DIN (S-Video)

Picture	Pin	Signal
	1	GND (Y)
	2	GND (C)
	3	Luminance (Y)
	4	Chrominance (C)

D-Sub 9 (EGA)

Picture	Pin	EGA	CGA	MDA
	1	GND	GND	GND
	2	Red (LSB)	–	–
	3	Red (MSB)	Red	–
	4	Green (MSB)	Green	–
	5	Blue (MSB)	Blue	–
	6	Green (LSB)	Intensity	Intensity
	7	Blue (LSB)	–	Video
	8	H-SYNC	H-SYNC	H-SYNC
	9	V-SYNC	V-SYNC	V-SYNC

Power Supply

Picture	Pin	Signal
 <p>5VDC</p>	Inside	VCC (+5VDC)
	Outside	GND

7.4 Power Supply

Voltage	5VDC
Power Requirement	<ul style="list-style-type: none"> • TH-C-VGA-DVI: max. 900 mA • TH-C-MA -DVI /-SDI-DVI /-RGB-DVI: max. 1,100 mA

7.5 Environmental Conditions

Operating Temperature	41 to 113°F (5 to 45°C)
Storage Temperature	-13 to 140°F (-25 to 60°C)
Relative Humidity	Max. 80% non-condensing

7.6 Size

TH-C-VGA-DVI

Media- / DVI-Converter	103 x 143 x 29 mm (4" x 5.6" x 1.1")
Shipping Box	210 x 140 x 165 mm (8.3" x 5.5" x 6.5")

TH-C-MA -DVI /-SDI-DVI /-RGB-DVI

Media- / DVI-Converter	103 x 143 x 43 mm (4" x 5.6" x 1.7")
Shipping Box	460 x 250 x 120 mm (18.1" x 9.8" x 4.7")

7.7 Shipping Weight

TH-C-VGA-DVI

Media- / DVI-Converter	0.3 kg (0.7 lb)
Shipping Box	1.8 kg (4.0 lb)

TH-C-MA -DVI /-SDI-DVI /-RGB-DVI

Media- / DVI-Converter	0.4 kg (0.9 lb)
Shipping Box	2.3 kg (5.1 lb)

8 Troubleshooting

8.1 Blank Screen

Diagnosis	Possible Reason	Measure
Status LED blue	No video signal detected	<ul style="list-style-type: none"> ➔ Check connections. ➔ Check input selection in the OSD (source type). ➔ Load DDC information of the connected monitor (see Chapter 6.2, Page 37). Reboot CPU if necessary.
Status LED green	No monitor detected	➔ Check connection, length and quality of the DVI-D cable to monitor, tighten cable thumbscrews.
Status LED dark red	No monitor detected	➔ Check connection, length and quality of the DVI-D cable to monitor, tighten cable thumbscrews.
	Resolution on device side not supported	➔ Please contact customer support at: http://www.telecast-fiber.com/support/ so that customer specific video mode can be made.
Status-LED violet	Resolution on device side not supported	➔ Please contact customer support at: http://www.telecast-fiber.com/support/ so that customer specific video mode can be made.

8.2 Picture

Diagnosis	Possible Reason	Measure
Incorrect picture display	Connection between disturbed	➔ Check connection, length and quality of the DVI-D cable to monitor, tighten cable thumbscrews.
	Transmission parameters not suitable or not optimally set for conditions.	➔ Run 'Auto Configuration' (see Chapter 5.2.2, Page 26). ➔ If necessary, set parameters for picture settings manually (e.g. phase and clock) (see Chapter 5.2.2, Page 26).
Parts of the picture are missing	Wrong setting of picture size	➔ Optimize picture settings (see Chapter 6.1, Page 35).
Horizontal picture jitter	Wrong settings of phase and clock	➔ Readjust phase and clock manually (see Chapter 5.2.2, Page 26).
Characters are smeared	Wrong setting of phase	➔ Readjust phase manually (see Chapter 5.2.2, Page 26).
Fine vertical lines are missing	Wrong setting of clock	➔ Readjust clock manually (see Chapter 5.2.2, Page 26).

8.3 General

Diagnosis	Possible Reason	Measure
Infrared remote control is non-functional	Wrong device selected	➔ Press the button <DEV ALL> on the infrared remote control to get a device-independent access to the functions.

9 Technical Support

Prior to contacting support please ensure you have read this manual, and then installed and set-up your Media- / DVI-Converter as recommended.

9.1 Support Checklist

To efficiently handle your request, please keep the following information available before you call:

- Company, name, phone number and email
- Type and serial number of the device (see bottom of device)
- Date and number of sales receipt, name of dealer if necessary
- Issue date of the existing manual
- Nature, circumstances and duration of the problem
- Involved components (such as graphic source/CPU, OS, graphic card, monitor, USB-HID/USB 2.0 devices, interconnect cable) including manufacturer and model number
- Results from any testing you have done

9.2 Shipping Checklist

1. To return your device, contact your dealer to obtain a RMA number (Return-Material-Authorization).
2. Package your devices carefully, preferably using the original box. Add all pieces which you received originally.
3. Note your RMA number visibly on your shipment.



Devices that are sent in without a RMA number cannot be accepted. The shipment will be sent back without being opened, postage unpaid.

10 Regulatory and Standards Compliance

10.1 CE Declaration Of Conformity

All the products presented in this manual comply with the provisions of the following European Directives:

2004/108/EG Council Directive on the approximation of the laws of the Member States relating to electromagnetic compatibility



CE Marking 2009

The products comply with the following harmonized standards for Information Technology Equipment:

- EN 55022:2006 + A1:2007 (Class A)
- EN 55024:1998 + A1:2001 + A2:2003

This declaration certifies the conformity to the specified directives but contains no assurance of properties. The safety instructions and installation guidelines noted in this manual shall be considered in detail. Compliance with the specifications for cable lengths and types is mandatory.



Use in a Domestic Environment

This is a Class A product. In a domestic environment, this product may cause radio interference in which case the user may be required to take adequate measures.

10.2 North American Regulatory Compliance

This equipment has been found to comply with the limits for a Class A digital device, pursuant to Part 15 of the FCC Rules. These limits are designed to provide reasonable protection against harmful interference when the equipment is operated in a commercial environment. This equipment generates, uses, and can radiate radio frequency energy and, if not installed and used in accordance with the instruction manual, may cause harmful interference to radio communications. Operation of this equipment in a residential area is likely to cause harmful interference in

which case the user will be required to correct the interference at his own expense.

Changes or modifications not expressly approved by the party responsible for compliance could void the user's authority to operate the equipment.

Shielded cables must be used with this equipment to maintain compliance with radio frequency energy emission regulations and ensure a suitably high level of immunity to electromagnetic disturbances.

All power supplies are certified to the relevant major international safety standards.

10.3 WEEE

The manufacturer complies with the EC Directive 2002/96/EG on the prevention of waste electrical and electronic equipment (WEEE).

The device labels carry a respective marking.

10.4 RoHS

This device complies with the EC Directive 2002/95/EG on the Restriction of the use of certain Hazardous Substances in electrical and electronic equipment (RoHS).

The device labels carry a respective marking.

11 Glossary

The following terms are commonly used in this guide or in video and KVM technology:

Term	Explanation
Cat X	Any Cat 5e (Cat 6, Cat 7) cable
CGA	The Color Graphics Adapter (CGA) is an old analog graphic standard with up to 16 displayable colors and a maximum resolution of 640x400 pixels.
Component Video	The Component Video (YPbPr) is a high-quality video standard that consists of three independently and separately transmittable video signals, the luminance signal and two color difference signals.
Composite Video	The Composite Video is also called FBAS and it is part of the PAL TV standard.
CON Unit	Component of a Media- / DVI-Converter or Media Extender to connect to the console (monitor(s), keyboard and mouse; optionally also with USB 2.0 devices)
CPU Unit	Component of a Media- / DVI-Converter or Media Extender to connect to a source (computer, CPU)
DDC	The Display Data Channel (DDC) is a serial communication interface between monitor and source (computer, CPU). It allows a data exchange via monitor cable and an automatic installation and configuration of a monitor driver by the operating system.
Dual Access	A system to operate a source (computer, CPU) from two consoles
Dual-Head	A system with two video connections
Dual-Link	A DVI-D interface for resolutions up to 2560x2048 by signal transmission of up to 330 MPixel/s (24-bit)
DVI	Digital video standard, introduced by the Digital Display Working Group (http://www.ddwg.org). Single Link and Dual Link standard are distinguished. The signals have TMDS level.
DVI-I	A combined signal (digital and analog) that allows running a VGA monitor at a DVI-I port – in contrast to DVI-D (see DVI).
Fiber	Single-mode or multi-mode fiber cables

Term	Explanation
EGA	The Enhanced Graphics Adapter (EGA) is an old analog graphic standard, introduced by IBM in 1984. A D-Sub 9 connector is used for connection.
FBAS	The analog color video baseband signal (FBAS) is also called Composite Video and it is part of the PAL TV standard.
Console	Keyboard, mouse and monitor
KVM	Keyboard, video and mouse
Mini-XLR	Industrial standard for electrical plug connections (3 pole) for the transmission of digital audio and control signals
Multi-mode	62.5μ multi-mode fiber cable or 50μ multi-mode fiber cable
OSD	The On-Screen-Display is used to display information or to operate a device.
Quad-Head	A system with four video connections
RCA (Cinch)	A not standardized plug connection for transmission of electrical audio and video signals, especially with coaxial cables
SFP	SFPs (Small Form Factor Pluggable) are pluggable interface modules for Gigabit connections. SFP modules are available for Cat X and fiber interconnect cables.
Single-Head	A system with one video connection
Single Link	A DVI-D interface for resolutions up to 1920x1200 by signal transmission of up to 165 MPixel/s (24-bit). Alternative frequencies are Full HD (1080p), 2K HD (2048x1080) and 2048x1152.
Single-mode	9μ single-mode fiber cable
S-Video (Y/C)	The S-Video (Y/C) is a video format transmitting luminance and chrominance signals separately. Thereby it has a higher quality standard than FBAS.
TOSLINK	Standardized fiber connection system for digital transmission of audio signals (F05 plug connection)
Triple-Head	A system with three video connections

Term	Explanation
USB-HID	<p>USB-HID devices (Human Interface Device) allow for data input.</p> <p>There is no need for a special driver during installation; "New USB-HID device found" is reported.</p> <p>Typical HID devices include keyboards, mice, graphics tablets and touch screens. Storage, video and audio devices are not HID.</p>
VGA	<p>Video Graphics Array (VGA) is a computer graphics standard with a typical resolution of 640x480 pixels and up to 262,144 colors. It can be seen as a follower of the graphics standards MDA, CGA and EGA.</p>