

IQATBS Composite Timebase Corrector



Module Description

The IQATBS provides multi-standard Y-C and composite timebase correction and synchronisation. The composite input automatically detects PAL, NTSC, NTSC-J, PAL, PALN, N4.4 and SECAM, and is sampled and decoded using an adaptive line comb filter to ensure optimum decoding performance. The signal correction features include luminance and chrominance gain, black level, NTSC hue, linear horizontal enhancer, Y-C horizontal timing and picture position. Rugged sync and clock recovery ensures reliable operation with unstable and noisy inputs.

In addition a powerful frame recursive noise reducer is able to automatically eliminate much background noise. A motion detector switches off the noise reduction in moving picture areas.

The broadcast quality output encoder with dual 10 bit oversampled DAC's is fully genlockable to a composite reference and supports PAL, NTSC, NTSCJ, PALM, PALN and SECAM. The IQATBS will also operate as a transcoder between any of the available standards of the same line rate.

Other features include Freeze, pattern generation, power off composite bypass and GPI control / audio delay flag output. Full RollCall remote control is available.

REAR PANEL VIEW

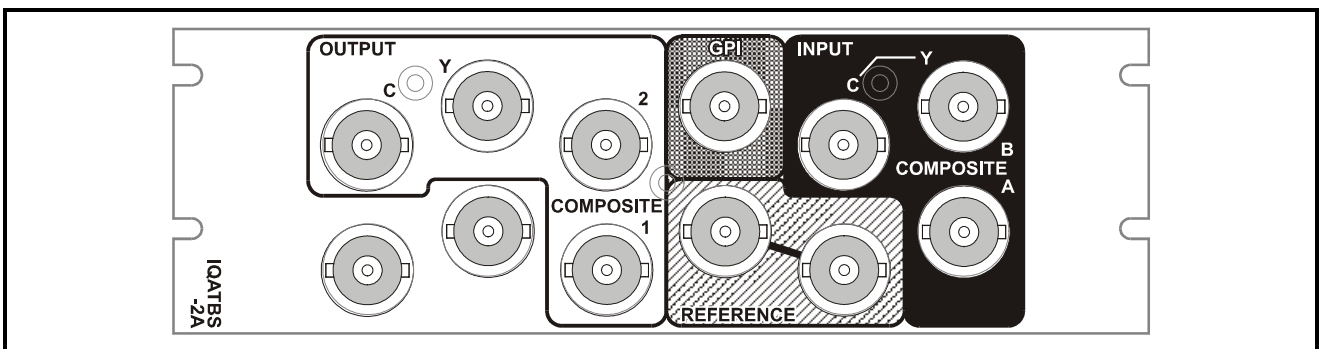
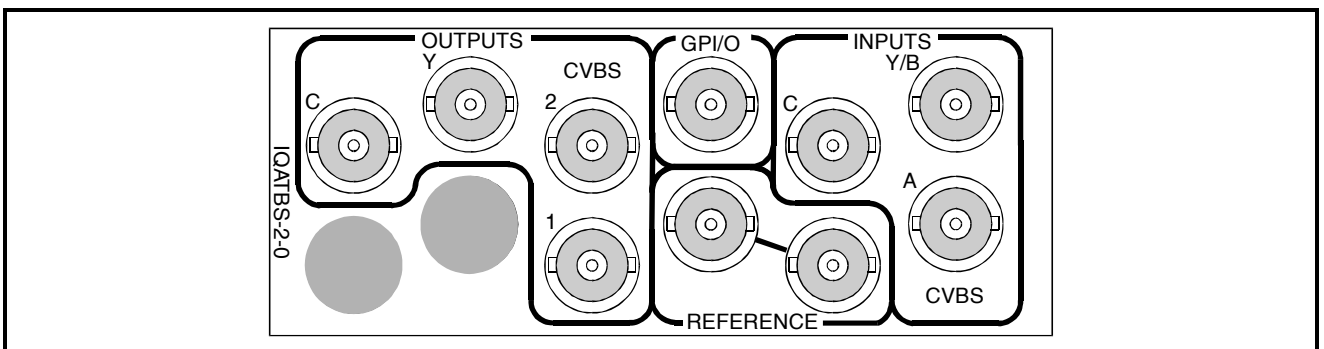

Versions of the module cards available are:

- | | | |
|------------|------------------------------|---------------------|
| IQATBS-2-0 | Composite Timebase Corrector | Double width module |
| IQATBS-2A | Composite Timebase Corrector | Double width module |

Note that there are two styles of rear panels available. They are not interchangeable between the two styles of enclosures. However, the cards may be fitted into any style of enclosure.

'A' Style Enclosure

Rear panels **with** the suffix A may only be fitted into the 'A' style enclosure shown below.

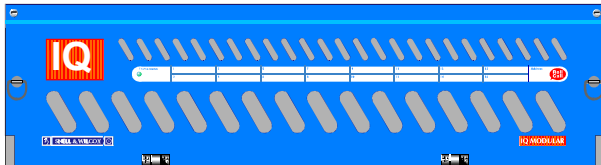

(Enclosure order codes IQH3A-E-0, IQH3A-E-P, IQH3A-0-0, IQH3A-0-P)

'O' Style Enclosures

Rear panels **without** the suffix A may only be fitted into the 'O' style enclosures shown below.

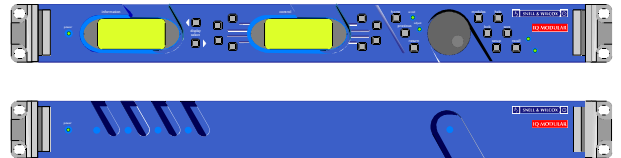

(Enclosure order codes IQH1S-RC-0, IQH1S-RC-AP, IQH1U-RC-0, IQH1U-RC-AP, Kudos Plus Products)

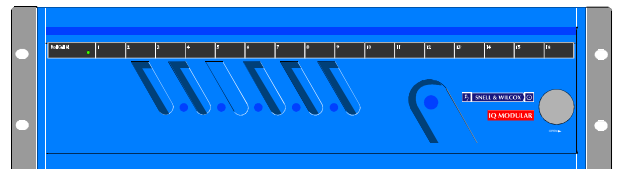

(Enclosure order codes IQH3N-0, IQH3N-P)



(Enclosure order codes IQH3U-RC-0, IQH3U-RC-P)

BLOCK DIAGRAM

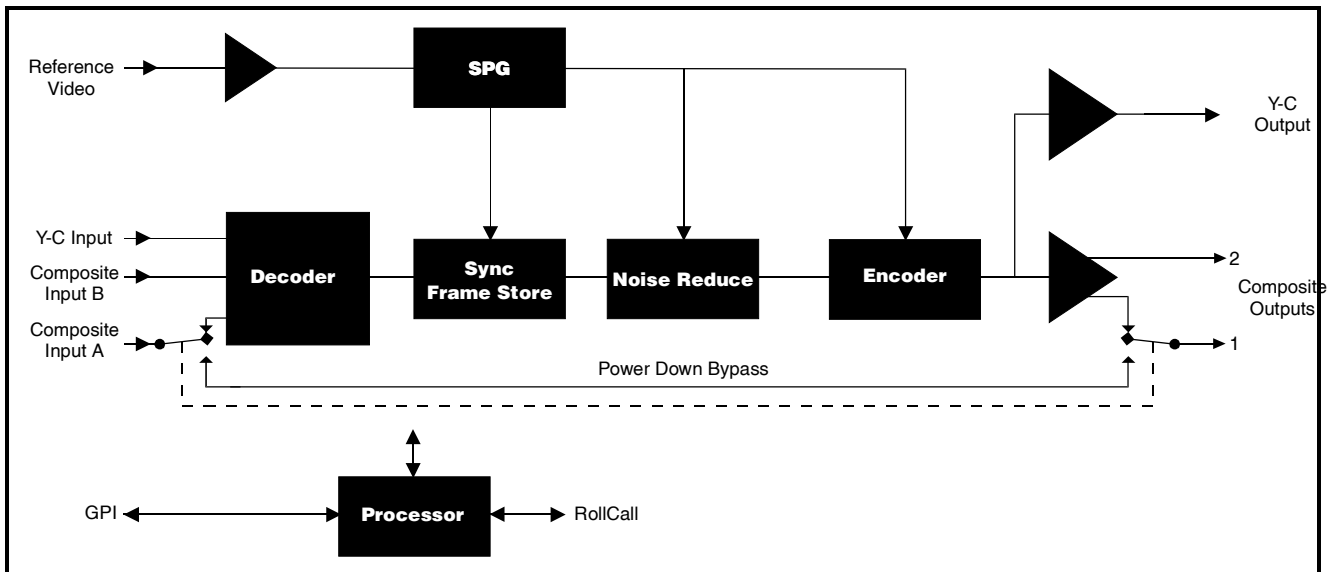

Features

- 4:2:2 frame synchronizer / timebase corrector
- Motion adaptive recursive noise reducer with automatic noise floor measurement
- Linear horizontal enhancer
- 10-bit internal processing
- Auto standards detection
- Input standards - PAL, NTSC, NTSC-J, PAL-N, PAL-M, N4.43 and SECAM
- Output standards - PAL, NTSC, NTSC-J, PAL-N, PAL-M and SECAM
- Y-C and Composite input / output
- PAL Hanover bar suppression
- Handles VHS tape playback feature modes
- Genlockable SPG with phasing adjustments
- Test signal generator (100/75% color bars, multi-burst, black)
- VITS insertion on composite / Y/C outputs
- PAL Line 23 and NTSC Line 21 process As Video, pass or blank
- Selectable Automatic Gain Control
- Selectable ACC referenced to color burst
- Adjustment of luma gain, black level, chroma gain, NTSC Hue and horizontal timing
- Frame freeze, black or input pass through on loss of input
- Power-down bypass (composite A in to composite 1 output)
- Vertical information passed or blanked on either composite / Y/C
- Delay Flag (GPI/O port) output and RollTrack for audio tracking
- Programmable GPI/O port
- 8 programmable memories
- Full RollCall remote control available as an upgrade

TECHNICAL PROFILE

Features

Inputs

Composite	2 x BNC connectors
Standards	PAL, NTSC, NTSC-J, PAL-N, PAL-M, N4.43, SECAM
Y-C	Via BNC connectors
Standards	PAL, NTSC, NTSC-J, PAL-N, PAL-M, N4.43, SECAM
Video Reference	Loop through BNCs; Composite Video or Black Burst

Outputs

Composite	2 x BNC
Standards	PAL, NTSC, NTSC-J, PAL-N, PA-LM, SECAM
Y-C	Via BNC
Standards	PAL, NTSC, NTSC-J, PAL-N, PAL-M, SECAM

Control Interface

GPI/O.....	Connector / Format BNC; Closing contact input/output
------------	---

Card Edge Controls (also available via RollCall)

Input select	Composite A, composite B, YC
Pedestal.....	Switches between NTSC and NTSC-J inputs
Freeze	On / Off
Pattern	On / Off
Luminance Gain.....	± 3 dB in 0.1 dB steps
Chroma Gain	± 3 dB in 0.1 dB steps
Black Level	±100 mV in 1.6 mV steps
Genlock	On/Off, Sch Lock, HV Lock

Indicators

Input Loss	Illuminates if input signal is lost
Input Error.....	Flashes if input signal is invalid
Reference Loss.....	Illuminates if reference signal is lost or is invalid

Functions available via RollCall only

Input Standard	PAL, PAL-N, SECAM, NTSC, PAL-M, NTSC-J, N4.43
----------------------	--

Output Standards 625	PAL, PAL-N, SECAM
Output Standards 525	NTSC, PAL-M, NTSC-J
NTSC Hue.....	360° in 1° steps
Luma Noise Reduction.....	Off / [On: Low, Medium, High]
Chroma Noise Reduction ...	Off / [On: Low, Medium, High]
Enhance.....	Off / [On: De, Low, Medium, High]
Automatic Gain Control	On / Off (Automatic Range +3 dB to -6 dB)
Automatic Chroma Gain Control	On / Off
Insert VITS.....	On / Off
Pass vertical data.....	On / Off
PAL Line 23	Process as video / Pass / Blank
NTSC Line 21	Process as video / Pass / Blank
SECAM Notch filter	On / Off
SECAM Bottles	On / Off
SECAM carrier	On / Off
SECAM Chroma Pre-Filter ..	On / Off
Noise Reduction Split screen	Off / Top Bottom split, Left Right split
Pattern Select	Black, Multi-burst, 75% color bars, 100% color bars
Y/C Timing	±1036 ns in 148 ns steps
Picture Position	±1036 ns in 148 ns steps
Default Output.....	Input, Pattern, Freeze, Stable Input
Logging (via RollCall)	Reference, Input
GPI action	Memories 1 to 8, Pattern, Freeze
GPO	Off, [On: Delay Flag, Input Loss, polarity high/low]
RollTrack Setup	Enable Unit 1.8
8 User Memories.....	[store / name / recall]
Preset Memories.....	Returns all memory settings to factory defaults
Preset Unit	Returns all unit settings to factory defaults
Reset Unit	Implements a power-down, power-up cycle

TECHNICAL PROFILE (cont.)**Specifications****Input**

Return Loss	Better than -30 dB to 5 MHz
Composite Level	1 V pk-pk typ. Into 75 ohms
Y Level.....	1 V pk-pk into 75 ohms
C Level	Color Burst at standard level into 75 ohms
Reference Level.....	Composite or Black Burst at standard level via loop-thru connection (>10 k ohm)

Output

Return Loss	<-15 dB at 270 MHz
-------------------	--------------------

System Parameters

Internal Processing	4:2:2
Y Frequency Response.....	5 MHz +0.2 dB, -0.5 dB
C Frequency Response.....	1.5 MHz -3 dB typ
Signal / Noise.....	Better than -60 dB (Wgtd, ramp)
K-2T	Better than 1%
Subcarrier Rejection.....	Better than 46 dB (PAL, NTSC) (75% Red)
Y-C delay error.....	±20 ns

Power Consumption

Module Power Consumption	12.9 W max
--------------------------	------------

INPUT CONNECTIONS

Composite A and B

These are the 2 Composite video inputs to the decoder module via BNC connectors. Nominal input level is 1 V p-p terminated in 75 Ohms.

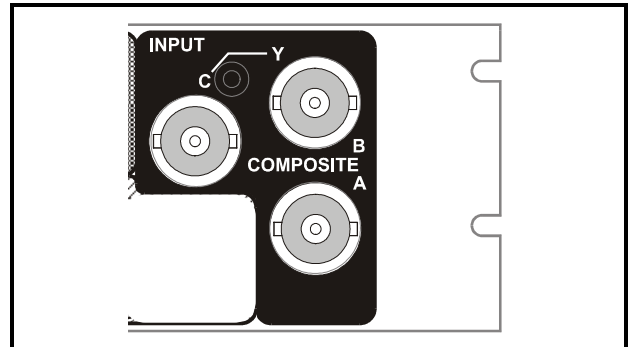
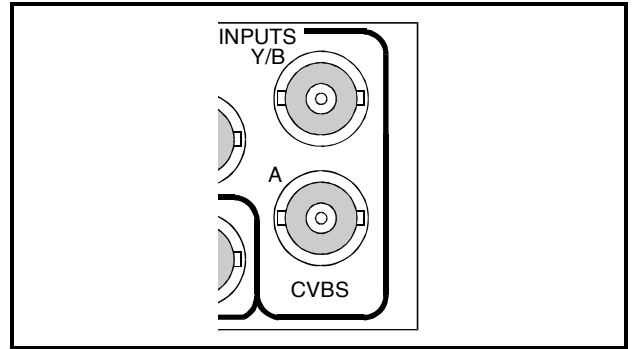

Separated Y C

A Y-C (S-VHS, Hi-8 etc.) input signal may be connected to the unit via 2 BNC connectors marked Y and C.

Y input level is a nominal 1V p-p into 75 Ohms.
C input is nominal color burst level into 75 Ohms.

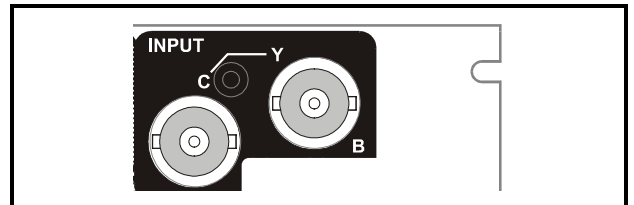
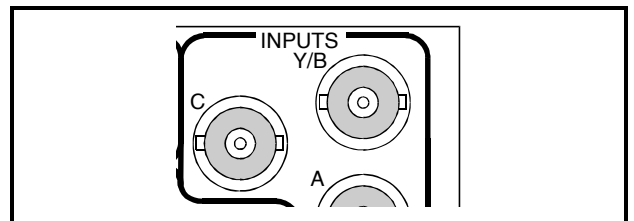

Reference Input

When suitable signals are connected to this input, the video output of the unit will be fully synchronised to the reference signal source when the genlock function is selected. If no signal is present the unit will automatically revert to internal free-running operation.

BNC loop-through connectors are provided and the signal may be black burst or composite video at standard level.

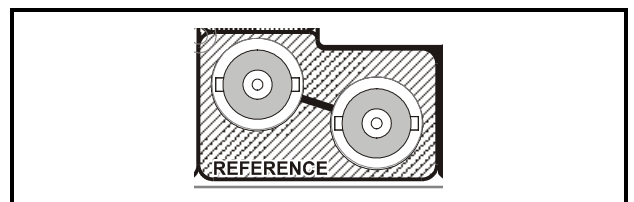
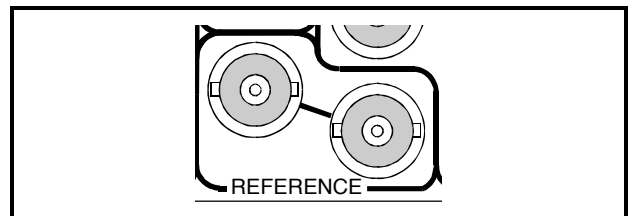

OUTPUT CONNECTIONS

CVBS (Composite) Outputs 1 & 2

Two isolated composite outputs are available from these BNC connectors.
Output level is standard 1V p-p into 75 Ohms.

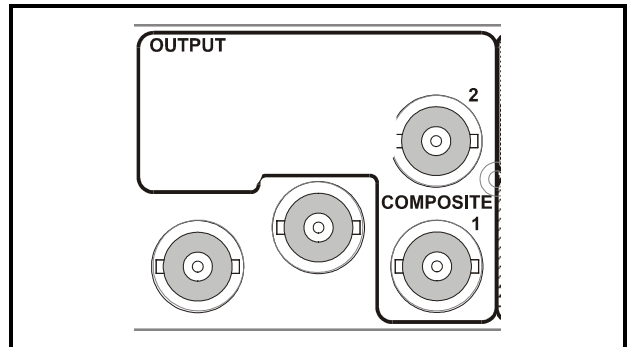
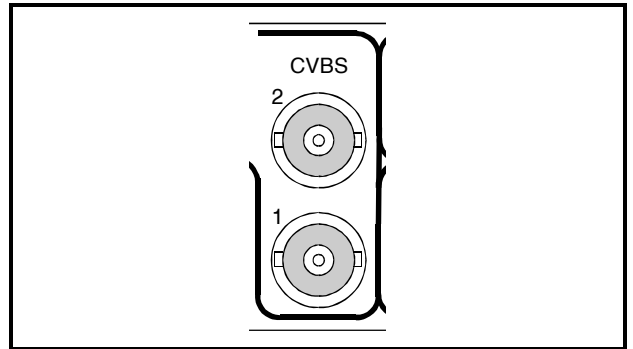

Y-C Separated Output

A Y-C (S-VHS/Hi-8) output signal is available via these 2 BNC connectors marked Y and C.

Y output level is a nominal 1 V p-p into 75 Ohms
C output is a nominal color burst level into 75 Ohms

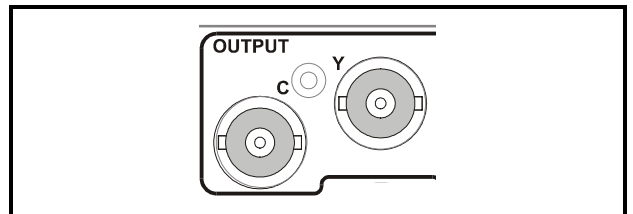
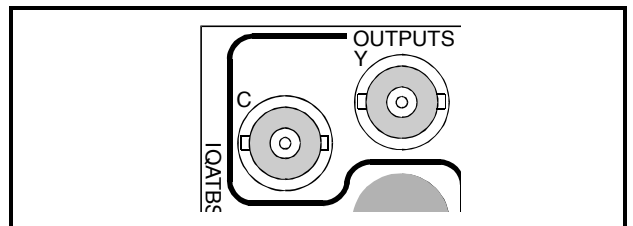

GPI I/O

This BNC connector provides GPI input and output control for the module.

Input Functions Selects pattern as output.
 Recalls memory.
 Selects freeze function.

Output Functions Provides a flag representing the video delay through the unit.
 Indicates a loss of input signal.

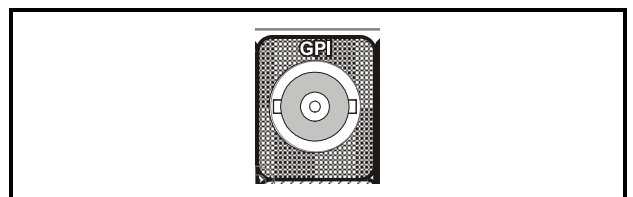
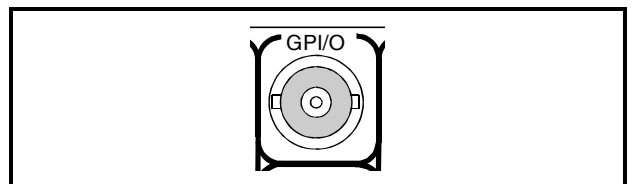

CARD EDGE CONTROLS

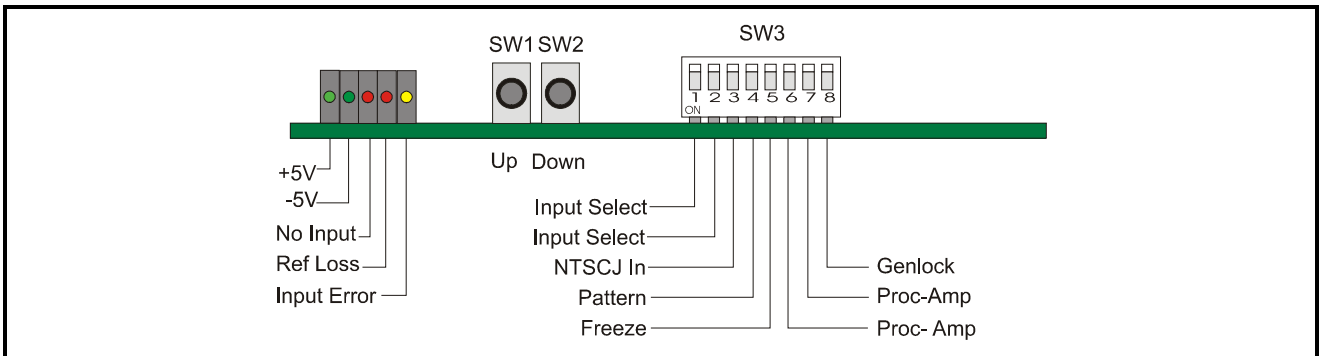

The unit will respond simultaneously to either remote RollCall commands or card-edge control settings one system overriding the settings of the other.

For cards using the RollCall™ remote control system, activating these switches will override the remote control settings. The RollCall™ control panel will then follow these settings.

The current settings are saved in an on-board memory.

If the remote link (LK1) is fitted the saved control settings are used when the unit is powered-up. If the remote link (LK1) is not fitted the unit will take its control settings from the card edge switches where possible and otherwise will use the default settings.

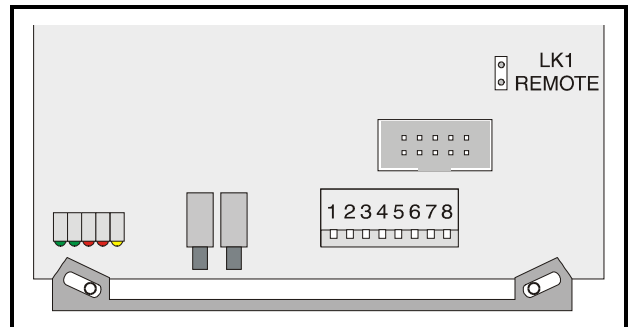

LED INDICATORS

+5V and -5V

When illuminated these LED's indicate that the +5 V and -5 V supplies are present.

No Input

The **No I/P** LED will be continuously illuminated when the unit is not receiving an input signal.

Ref Loss

This LED will be illuminated if the unit is not receiving a valid Reference signal.

Input Error

This LED will flash if the unit is receiving an invalid input signal.

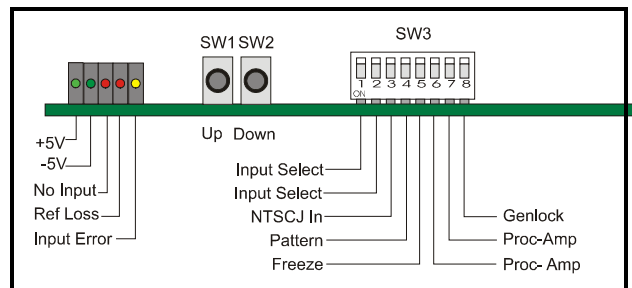

SWITCHES

Two push buttons and an 8 way DIL switch allow various functions and modes to be set.

The DIL switch SW3 selects a particular function.

The push buttons SW1, SW2 allow the value of the selected function/parameter to be adjusted.

Note that to select the preset value both buttons should be pressed together.

These switches allow the module to be operated when an active front panel is not available.

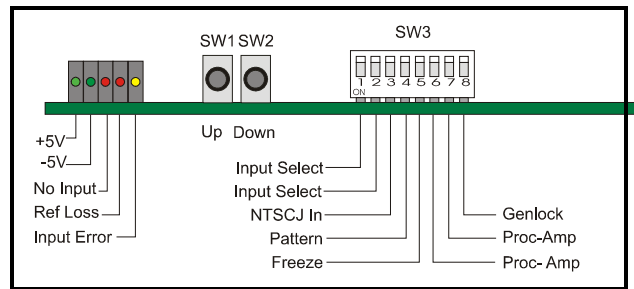

FUNCTION AND MODE SELECTIONS

DIL SWITCH FUNCTIONS SW3

By setting these switches various modes of operation may be selected.

(Down is ON and Up is OFF)

Position 1 and Position 2

These two positions allow the input to be selected.

Input	Position 1	Position 2
CVBS A	OFF	OFF
CVBS B	ON	OFF
YC	ON or OFF	ON

Position 3

Setting this to ON the decoder will correctly process a NTSCJ signal (an NTSC signal without pedestal)

Position 4

When set to ON this allows the unit to produce a **test pattern** signal as an output. When the test pattern is selected the ProcAmp functions are bypassed.

The pattern list (Black, 75% Color Bars, 100% Color Bars and Multiburst) will be cycled through by operating the push buttons SW1 and SW2

Position 5

When set to ON the output will become a frozen picture of the last frame.

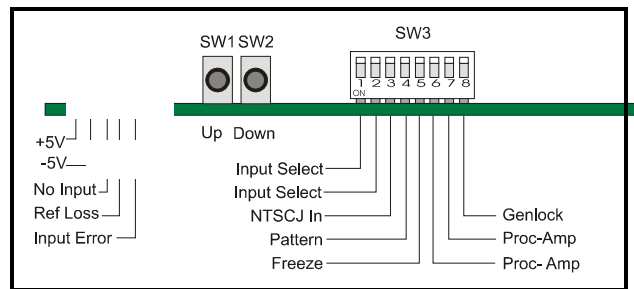

Position 6 and Position 7

These two positions allow the ProcAmp functions to be enabled and adjustments made to selected parameters.

Parameter	Position 6	Position 7
No functions enabled	OFF	OFF
Luminance Gain	ON	OFF
Black Level	ON	ON
Chrominance Gain	OFF	ON

Luminance Gain

Using the push buttons SW1, SW2 the gain may be adjusted by ± 3 dB in steps of 0.1 dB. Preset setting is to the calibrated value of 0 dB.

Black Level

Using the push buttons SW1, SW2 the pedestal may be adjusted by ± 102.4 mV in steps of 1.6 mV.

Chrominance Gain

Using the push buttons SW1, SW2 the gain may be adjusted by ± 3 dB in steps of 0.1 dB. Preset setting is to the calibrated value of 0 dB.

Position 8

When set to ON the unit will lock to an incoming valid reference signal with parameters set using this screen. When set to OFF the output signal will be free-running. In this mode the frequency accuracy will be ± 10 ppm.

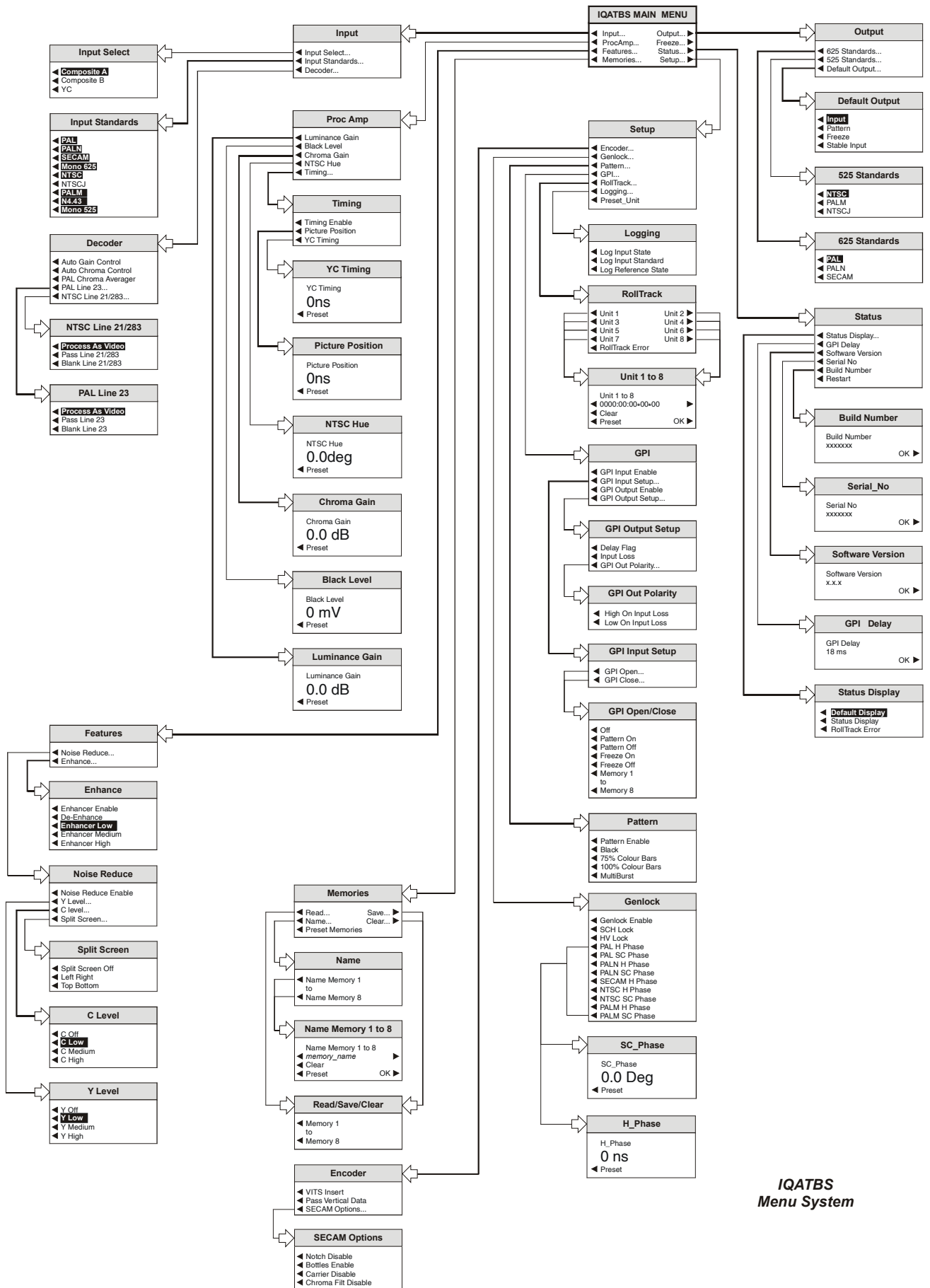

IQATBS Menu System

OPERATION FROM AN ACTIVE CONTROL PANEL

The card may be operated with an active control panel via the RollCall™ network. The menus available for this card are shown opposite and will appear in the Control display window.

Operational details for the remote control panel will be found in SECTION 1 of the Modular System Operator's Manual.

◀ **Input...**

This function allows the input parameters to be set.

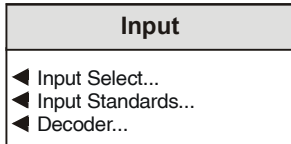

◀ **Input Select**

This allows any of the three sources of video input signal to be selected for processing.

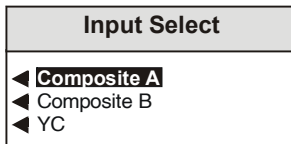

◀ **Input Standards**

The decoder employs an auto standard detection system. It will auto detect any of the standards that are checked in the list of standards.

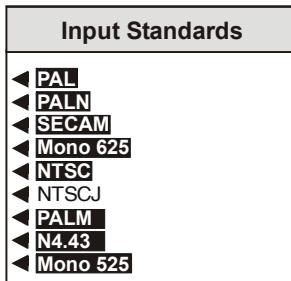

In the example above it will auto detect all standards except NTSCJ. Any number (one or more) of standards may be selected. For example, in a given situation where it is known that only PAL and NTSC input signals are expected, only the PAL and NTSC standards should be checked.

The decoder will then only auto detect between PAL and NTSC standards. Other standards will not be decoded and will switch to Default Output.

To force the unit to decode only one standard, check that standard and uncheck all others.

Note that at least one standard must be selected; if an attempt is made to uncheck all items the last standard selected will remain checked and become the only standard to be decoded.

For NTSC signals either NTSC **or** NTSCJ may be checked, but it is not possible to check both NTSC **and** NTSCJ.

The output **line** standard will be the same as the detected input standard. i.e. the output signal will be at a line rate of 625 if the detected input signal has a line rate of 625; similarly the output signal will be at a line rate of 525 if the detected input signal has a line rate of 525.

NTSCJ When this function is enabled the decoder will correctly process a NTSCJ signal (an NTSC signal without pedestal)

◀ Decoder

This function allows settings to be made to the decoder section.

Decoder
◀ Auto Gain Control
◀ Auto Chroma Control
◀ PAL Chroma Averager
◀ PAL Line 23...
◀ NTSC Line 21/283...

◀ Auto Gain Control

When this item is enabled the luminance gain will vary relative to the input peak white amplitude.

This will maintain the output signal at a normalised level even though the input signal level may be above or below standard level. The control will be effective over an input level range of +3 dB to -6 dB.

◀ Auto Chroma Control

When this item is enabled the chrominance gain will vary relative to the input burst amplitude. This will maintain correct color saturation regardless of changes in subcarrier amplitude.

◀ PAL Chroma Averager

When selected this will provide PAL Hanover bar suppression.

◀ PAL Line 23

This item allows various options to be applied to line 23 of the PAL input signal.

PAL Line 23
◀ Process As Video
◀ Pass Line 23
◀ Blank Line 23

◀ Process As Video

When enabled line 23 of the PAL input signal will be processed as active picture and the ProcAmp controls will effect Line 23.

◀ Pass Line 23

When selected (text reversed) the first half line of line 23 is passed unprocessed, the second half line is blanked and the ProcAmp controls will not effect Line 23.

◀ Blank Line 23

When enabled line 23 of the PAL input signal will be blanked.

◀ NTSC Line 21/283

This item allows various options to be applied to line 21/283 of the NTSC input signal.

NTSC Line 21/283
◀ Process As Video
◀ Pass Line 21/283
◀ Blank Line 21/283

◀ Process As Video

When enabled line 21/283 of the NTSC input signal will be processed and the ProcAmp controls will effect Line 21/283.

◀ Pass Line 21/283

When selected (text reversed) lines 21/283 are passed unprocessed and the ProcAmp controls will not effect Line 21/283.

◀ Blank Line 21/283

When enabled line 21/283 of the NTSC input signal will be blanked.

Note that the first half of line 283 on the composite (NTSC) output is always blanked.

◀ Proc_Amp...

This item allows various adjustments to be made to the video signal.

◀ Luminance Gain

This item will reveal a numerical readout display for the gain of the luminance signal.

By rotating the spinwheel the gain may be adjusted by ±3 dB in steps of 0.1 dB.

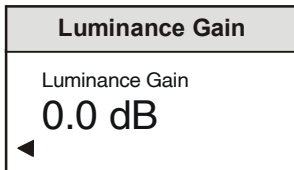

Selecting Preset returns the setting to the calibrated value of 0.

◀ Black Level

This item will reveal a numerical readout display for the Y pedestal or black level.

By rotating the spinwheel the pedestal may be adjusted by ±102.4 mV in steps of 1.6 mV.

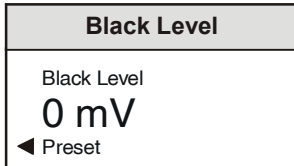

Selecting Preset returns the setting to the calibrated value of 0.

◀ Chroma Gain

This item will will reveal a numerical readout display for the gain of the chrominance signal.

By rotating the spinwheel the gain may be adjusted by ±3 dB in steps of 0.1 dB.

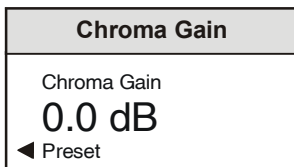

Selecting Preset returns the setting to the calibrated value of 0.

◀ NTSC Hue

This item will reveal a numerical readout display for the Hue of NTSC signals. By using the scroll bar the Hue may be adjusted by 360° in steps of 1°.



Selecting Preset returns the setting to the calibrated value of 0°

Note that this function will only be available for NTSC and NTSCJ signals.

◀ Timing

Timing
▶ Timing Enable ▶ Picture Position ▶ YC Timing

◀ Timing Enable

When this item is selected (text highlighted) the timing values will be enabled.

◀ Picture Position

Selecting this item will reveal a display showing the timing of the picture position relative to the normal value, in nanoseconds. Rotating the spin-wheel will adjust this value.

Picture Position
Picture Position 0ns ▶ Preset

Range is from ± 1036 ns in 148 ns steps.

Selecting Preset returns the setting to the preset value of 0.

◀ YC Timing

Selecting this item will reveal a display showing the timing of the chrominance signal relative to the luminance signal, (i.e. Y to Cb/Cr timing) in nanoseconds. Rotating the spin-wheel will adjust this value.

YC Timing
YC Timing 0ns ▶ Preset

Range is from ± 1036 ns in 148 ns steps.

Selecting Preset returns the setting to the preset value of 0.

◀ **Features...**

This item allows noise reduction and enhancement to be applied to the signal.

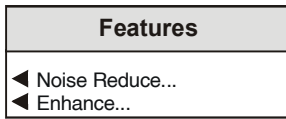

◀ **Noise Reduce**

This item allows Recursive noise reduction with automatic threshold to be applied to the Luminance and Chrominance channels.

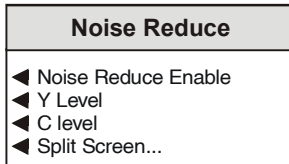

◀ **Noise Reduce Enable**

When this item is selected (text highlighted) the Y noise reduction function will be enabled. This function will toggle the Noise Reduce function On or Off.

◀ **Y level**

When this item is selected a menu will be revealed that allows the amount of Y noise reduction applied may be chosen.

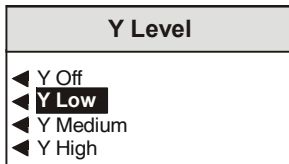

◀ **C level**

When this item is selected a menu will be revealed that allows the amount of C noise reduction applied may be chosen.

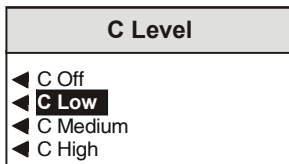

*Note that the Preset Unit function in the **Setup** menu turns the Noise Reduce function OFF and returns the Y and C Noise Reduce Level values to Low.*

◀ **Split Screen**

To enable the effects of noise reduction to be easily seen this function allows the screen to be split into 2 halves either left/right or top/bottom. One half will show the picture with noise reduction and the other half without noise reduction.

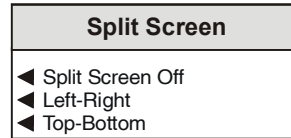

◀ **Split Screen Off**

When this item is selected (text highlighted) this will disable the split screen function.

◀ **Left-Right**

When enabled the screen will be split into two equal sections separated by a vertical white line. The processed picture will occupy the left hand section of the screen and the unprocessed picture will occupy the right hand side section.

◀ **Top-Bottom**

When enabled the screen will be split into two equal sections separated by a horizontal white line. The processed picture will occupy the top section of the screen and the unprocessed picture will occupy the bottom section.

◀ Enhance

This item will reveal a menu that allows various levels of enhancement to be applied to the signal.

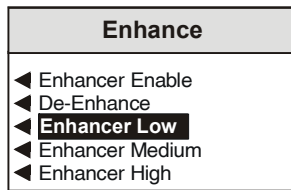

This function allows Horizontal enhancement to be applied to the processed signal. The non-linear process prevents enhancement of low amplitude signals typical of noise.

◀ Enhance Enable

When this item is selected (text highlighted) the enhancement value selected in the above menu will be applied.

Note that the De Enhance selection will de-enhance the signal. This setting is useful when processing signals that may have been previously over-enhanced.

Preset Unit is to Enhancer Low.

◀ **Memories...**

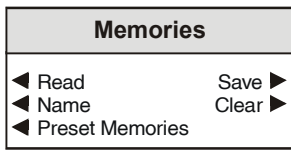

This function allows a number of particular setups of the IQATBS to be saved, recalled, cleared and re-named. There are 8 memory locations available.

◀ **Read** (a memory location number)

This will reveal a list of the memory locations.

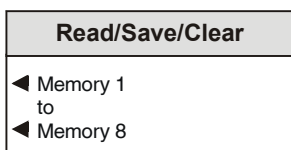

Selecting a memory location will recall the settings stored in the selected memory location and apply them to the unit.

◀ **Save** (a memory location number)

This will reveal a list of the memory locations.

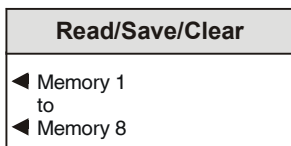

Selecting a memory location will save the settings and store them in the selected memory location.

◀ **Clear** (a memory location number)

This will reveal a list of the memory locations.

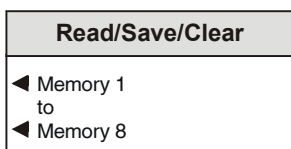

This item will return the contents of the selected memory location to the default (factory) values.

◀ **Name** (a memory location)

This will reveal a list of the memory locations and allow the naming of the selected memory location.

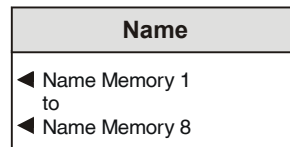

◀ Name Memory 1 to 8

Selecting a memory location will reveal the following item that allows the naming of the selected memory location.

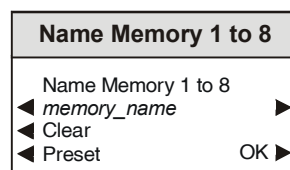

To compile/edit the text the right ▶ and left ◀ buttons adjacent to the upper text line in the menu should be used to select the character position in the text and the spinwheel used to select the character.

The ◀ **Clear** function blanks out the selected character.

The ◀ **Preset** function loads the default text, for example, *Memory_1*.

O.K. ▶ saves the caption text and returns to the previous menu.

Output... ▶

The output line standard will always be the same as the detected input line standard.

This menu allows the encoded formats for 625 or 525 line standards to be selected.

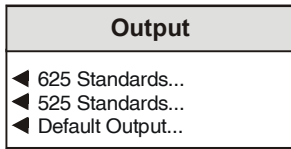

◀ 625 Standards...

This function allows the encoded format in the 625 line standard to be selected.

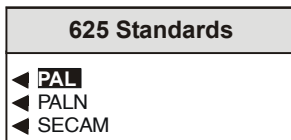

◀ 525 Standards...

This function allows the encoded format in the 525 line standard to be selected.

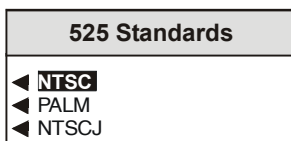

When the NTSCJ is enabled the encoder will produce an NTSCJ signal (an NTSC signal without pedestal)

◀ Default Output...

If the input signal fails the output may be configured to become one of the items in this menu.

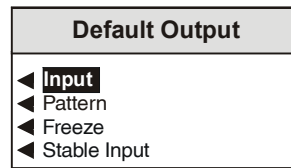

- Input** The output will be the unprocessed input signal.
- Pattern** The output will become the test pattern as selected from the Control/Pattern menu.
- Freeze** The output will become a frozen picture of the last frame.
- Stable Input** When the Freeze function is chosen the quality of the frozen picture will depend on the stability of the input signal.
If the input signal is known to be from a stable source this box should be checked as this will give the best quality frozen picture. If the input signal is not from a stable source this box should be unchecked.

Freeze ▶

This function toggles between a normal picture and a frozen picture.

Status... ▶

This menu allows various information about the status of the unit to be displayed.

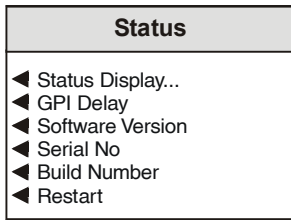

◀ Status Display...

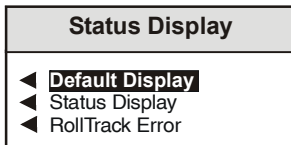

◀ Default Display (Toggles with ◀ Status Display)

When this item is selected the display window will show details about the Input Signal, Reference signal and the output as shown in the example below.

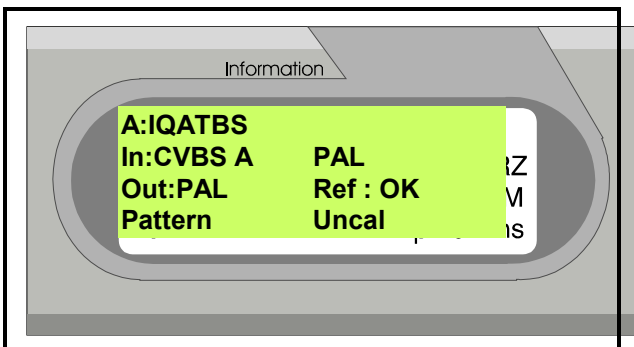

The first line will show the name of the module.

The second line will show which input has been selected and the detected standard of the input signal.

The third line shows standard of the output signal and the genlock status.

The fourth line will show the status of the output signal and the state of the ProcAmp controls. The output signal status may be **Nothing**, (output is processed picture), **Pattern** or **Freeze**.

Note that if Pattern or Freeze has been forced because of an input signal failure the words will be prefixed by an asterisk e.g ***Pattern** or ***Freeze**.

The word **Uncal** will displayed if the ProcAmp controls are not at their preset values.

◀ Status Display (Toggles with ◀ Status Display)

When this item is selected the display window will show details about the Input Signal and some of the processing controls as shown in the example below.

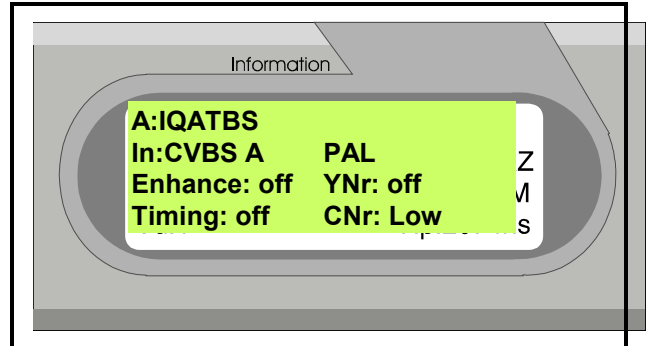

◀ RollTrack Error

When this item is selected error messages from other connected units will be shown in the display. e.g. If a message is sent to a unit and an acknowledgement is not received an error message will appear.

◀ GPI Delay

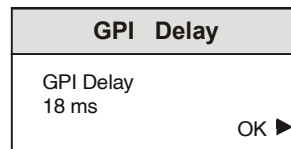

This function will display the total video delay through the unit in milliseconds.

◀ Software Version

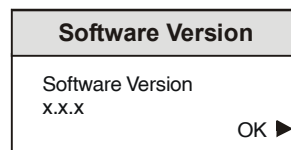

Selecting this item reveals a display showing the version of the software fitted in the module. Select OK to return to the Status Menu.

◀ **Serial No.**

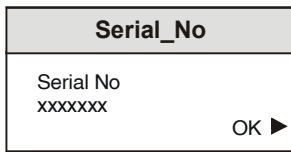

Selecting this item reveals a display showing the serial number of the module. Select OK to return to the Status Menu.

◀ **Build Number**

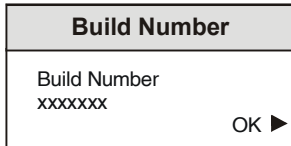

This will indicate the factory build number. This number defines all parameters of the unit (software versions, build level etc.) for identification purposes.

◀ **Restart**

This function allows the unit to reboot and all power-up settings to be enabled. This is an easier method than switching the mains power off and on.

Setup... ▶

This item will reveal a menu that allows various system parameters to be set.

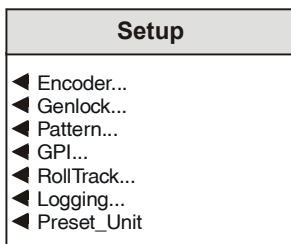

◀ **Encoder...**

This menu allows various parameters of the encoding section to be set up.

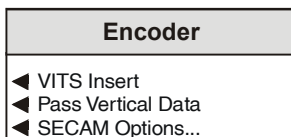

◀ **VITS Insert**

When this function is selected the normal VITS lines are inserted in the vertical interval.

◀ **Pass Vertical Data**

When selected (text reversed) the unit will pass data (unblanked) present in the vertical interval, to the output.

When de-selected (text normal) all data in the vertical interval will be blanked.

◀ **SECAM Options...**

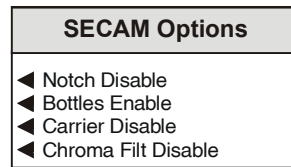

◀ **Notch Disable**

When selected (text highlighted) the SECAM luminance notch filter will be disabled.

Preset Unit is to notch filter ON.

◀ **Bottles Enable**

This function allows the SECAM-V color ident signal (Bottles) to be switched ON (text highlighted) or to OFF.

Preset Unit is to Bottles OFF.

◀ **Carrier Disable**

This function allows the chrominance carrier to be switched ON or OFF (text highlighted)

Preset Unit is to ON.

◀ **Chroma Filt Disable**

This function allows the chrominance filter to be switched OFF (text highlighted) or ON.

Preset Unit is to ON.

◀ **Genlock...**

This item will reveal a menu that allows various genlock phase adjustments to be made.

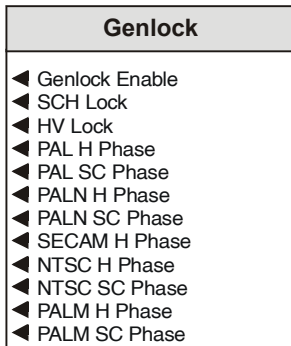

◀ **Genlock Enable**

When this item is selected (text highlighted) the genlock function will be enabled and the unit will lock to an incoming reference signal.

When not enabled the output signal will be free-running. In this mode the frequency accuracy will be ±10 ppm.

◀ **SCH Lock**

The unit will lock to the Line, Field and subcarrier signals of the reference signal.

◀ **HV Lock**

The unit will only lock to the Line and Field signals of the reference signal.

*Note that the **SC Phase** controls may be adjusted but the settings will be irrelevant in this mode.*

◀ (PAL/PALN/SECAM/NTSC/PALM) H Phase

Selecting this item reveals a display showing the horizontal timing of the output signal relative to the reference sync signal, in nanoseconds. Rotating the spin-wheel will adjust this value.

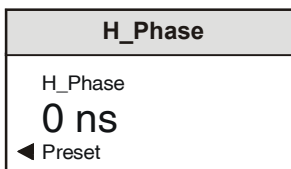

The range is approximately ±113 μs in steps of one cycle of subcarrier. (This ensures the correct SC/H timing is maintained)

Selecting Preset returns the setting to zero. (Output coincident with reference)

Note that the Preset_Unit function in the Setup menu will not change this setting.

◀ (PAL/PALN/SECAM/NTSC/PALM) SC Phase

This function allows the relative phasing between the reference subcarrier and the output signal subcarrier to be adjusted. Rotating the spin-wheel will adjust this value and the numerical display shows the phasing in degrees.

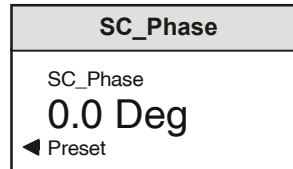

The range of adjustment is 359.9° (continuously adjustable) in steps of 0.1° and the preset value is 0° (Output coincident with reference)

Note that the Preset_Unit function in the Setup menu will not change this setting.

◀ **Pattern...**

This item will reveal a menu that allows various patterns to be selected from the list below and used as the output signal.

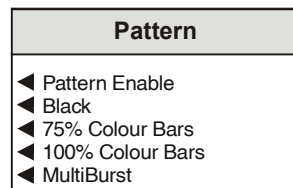

◀ **Pattern Enable**

When this item is selected (text highlighted) the selected pattern will become the output.

◀ **GPI...**

The GPI connection may be configured as an input (from mechanical switch contacts, relay contacts etc.) as an output or be completely disabled.

These configurations may be setup using this menu.

GPI
<ul style="list-style-type: none"> ◀ GPI Input Enable ◀ GPI Input Setup... ◀ GPI Output Enable ◀ GPI Output Setup...

Selecting the GPI Function

Function	Selection
Disabled	GPI Input Enable
Configured as an Input	GPI Input Enable
Disabled	GPI Output Enable
Configured as an Output	GPI Output Enable

Note that the GPI may be configured as an input *or* as an output but not as both; however it may be disabled as an input *and* disabled as an output.

◀ **GPI Input Setup...**

When configured as an input the unit the GPI will respond to either a closed to open transition (Open) or an open to closed transition (Close).

GPI Input Setup
<ul style="list-style-type: none"> ◀ GPI Open... ◀ GPI Close...

This item allows these two functions to be selected.

◀ **GPI Open/GPI Close...**

GPI Open/Close
<ul style="list-style-type: none"> ◀ Off ◀ Pattern On ◀ Pattern Off ◀ Freeze On ◀ Freeze Off ◀ Memory 1 to Memory 8

The resulting action that the unit takes on receipt of a valid GPI input may be selected from this menu.

◀ **Off**

When this item is selected no action will occur.

◀ **Pattern On**

On receipt of a valid GPI input the output will become the pattern that has been selected via the Pattern menu.

◀ **Pattern Off**

On receipt of a valid GPI input the pattern signal will be turned Off.

◀ **Freeze On**

On receipt of a valid GPI input the output will become a frozen picture.

◀ **Freeze Off**

On receipt of a valid GPI input the output picture will become unfrozen.

◀ **Memory 1 to Memory 8**

One of the eight memory locations may be selected. On receipt of a valid GPI input the settings stored in the selected memory location will be recalled.

◀ **GPI Output Setup...**

When the GPI is configured as an output the unit the GPI will produce an output signal.

GPI Output Setup
<ul style="list-style-type: none"> ◀ Delay Flag ◀ Input Loss ◀ GPI Out Polarity...

This item allows the type of output signal to be selected.

◀ **Delay Flag**

When enabled the output will represent the input/output time delay through the unit.

◀ **Input Loss**

When enabled the output will change when a loss of the selected input signal occurs.

◀ **GPI Out Polarity...**

This menu allows the polarity of the GPI output signal to be chosen.

GPI Out Polarity
<ul style="list-style-type: none"> ◀ High On Input Loss ◀ Low On Input Loss

◀ **RollTrack...**

This function allows the value of the delay time produced by this module to be sent, via the RollCall™ network, to audio delay units connected on the same network. This enables compatible audio delay units to produce an audio delay dependent on this and other similar units. The audio delay unit will dynamically follow or track the received delay-time information allowing processed video signals to be timed correctly with audio signals. This automatic tracking system via the RollCall™ network is called **RollTrack™**.

For more detailed information, see the RollTrack section (Appendix) at the end of this manual.

The destination for the delay information is set by the network code address as follows:

Selecting RollTrack provides a sub-menu that allows up to 8 audio delays to be selected as a destination.

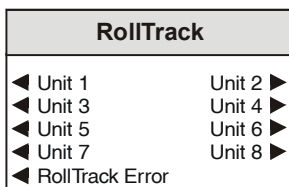

When a unit is selected a further sub-menu then appears to allow the code to be set up.

◀ **Unit 1 to 8**

A further sub-menu then appears to allow the code to be set up using the adjacent push buttons to edit the text.

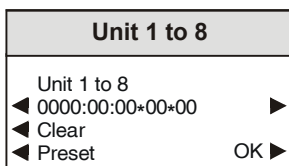

To edit the text the buttons adjacent to the upper text line in the menu are used to select the character position in the text and the spinwheel used to select the character.

(The right ▶ and left ◀ buttons select the cursor position and the spinwheel selects the character; the clear button sets the text line to all zero's and the OK button accepts the network address)

For more detailed information see the RollTrack section of this manual.

The full network address has five sets of numbers.

For example: 0000:10:01*14*51

The first set (0000) is the network segment code number

The second set (10) is the number identifying the (enclosure/mainframe) unit

The third set (01) is the slot number in the unit

The fourth set (14) separated by an * is the channel number.

Note that only channel numbers 14, 15, 16 & 17 should be used for audio delay cards.

The fifth set (51) is the board type identification.

Once a destination address for a unit has been set the OK function will return to the unit menu to allow another address to be set if required.

◀ **RollTrack Error**

When this item is enabled an error message will appear in the information window if an acknowledgement is not received from the RollTrack destination.

◀ Logging...

If a logging device is attached to the RollCall™ network, information about various parameters can be made available to such a device.

Selecting this item reveals a display that allows information to be made available for logging.

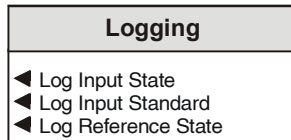
**◀ Log Input State**

When activated, a loss of input signal condition or change of input line standard will be available for the logging device.

◀ Log Input Standard

When activated, a loss of input signal condition or change of input line standard will be available for the logging device.

◀ Log Reference State

When activated a loss of reference signal condition will be notified to any logging device.

◀ Preset Unit

Selecting this item sets all adjustment functions that include a preset facility, to their preset values.

Note that this function will not change any genlock phase adjustment settings.

Note also that this is a momentary action and the text will not become reversed.

RollCall PC Control Panel Screens for the for the IQATBS

Control

Input Select

This allows any one of the three sources of video input signal to be selected for processing.

Pattern

This function will allow various patterns to be used as the output signal when the pattern Enable function is selected.

Feature Select

Freeze

The output will become a frozen picture of the last frame.

Pattern Enable

The output will become the pattern selected above.

Y Noise Reduce Enable

This will enable the luminance noise reduction. The level of noise reduction is set via the Setup screen.

C Noise Reduce Enable

This will enable the chrominance noise reduction. The level of noise reduction is set via the Setup screen.

Enhance Enable

This will enable the enhancement function. The level of enhancement is set via the Setup screen.

Genlock Enable

This will enable the genlock function.

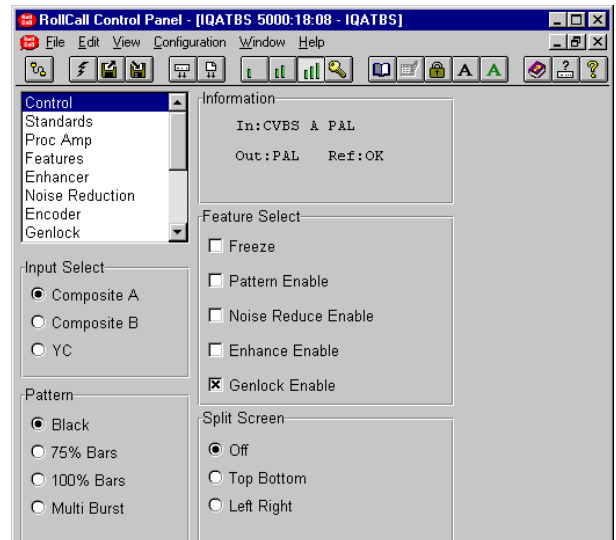

Split Screen

To enable the effects of noise reduction to be easily seen this function allows the screen to be split into 2 halves either left/right or top/bottom. One half will show the picture with noise reduction and the other half without noise reduction.

Off

This will disable the split screen function.

Top Bottom

When enabled the screen will be split into two equal sections separated by a horizontal white line. The processed picture will occupy the bottom section of the screen and the unprocessed picture will occupy the top section.

Left Right

When enabled the screen will be split into two equal sections separated by a vertical white line. The processed picture will occupy the right hand section of the screen and the unprocessed picture will occupy the left hand side section.

Standards

Input Standards

The decoder employs an auto standard detection system. It will auto detect any of the composite or Y/C standards that are checked in the list of Input Standards.

In the example above it will auto detect all standards except NTSC. Any number (greater than one) of standards may be selected. For example, in a given situation where it is known that only PAL and NTSC input signals are expected, only the PAL and NTSC standards should be checked.

The decoder will then only auto detect between PAL and NTSC standards. Other standards will not be decoded and will produce an unstable lock.

To force the unit to decode only one standard, check that standard and uncheck all others.

PAL Chroma 2 Line Averager

When selected this will provide PAL Hanover bar suppression.

Notes Concerning Input Standard Selection

At least one standard must be selected; if an attempt is made to uncheck all items the last standard selected will remain checked and become the only standard to be decoded. For NTSC signals either NTSC *or* NTSCJ may be checked, but it is not possible to check both NTSC *and* NTSCJ.

The output *line* standard will be the same as the detected input standard. i.e. the output signal will be at a line rate of 625 if the detected input signal has a line rate of 625; similarly the output signal will be at a line rate of 525 if the detected input signal has a line rate of 525.

NTSCJ

When this function is enabled the decoder will correctly process a NTSCJ signal (an NTSC signal without pedestal)

Default Output

If the input signal fails this function allows the output to be configured to become one of the following:

Input The output will be the unprocessed input signal.

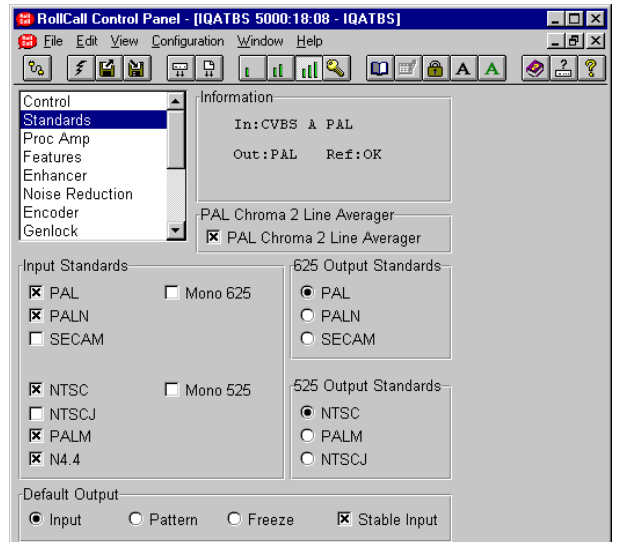

Pattern The output will become the test pattern as selected from the Control/Pattern menu.

Freeze The output will become a frozen picture of the last frame.

Stable Input When the Freeze function is chosen the quality of the frozen picture will depend on the stability of the input signal. If the input signal is known to be from a stable source this box should be checked as this will give the best quality frozen picture. If the input signal is not from a stable source this box should be unchecked.

Output Standard

The output line standard will always be the same as the detected input line standard. These items allow the encoded formats for the different line standards to be selected.

625 Output Standards

This item allows the encoded formats for 625 line standards to be selected.

525 Output Standards

This item allows the encoded formats for 525 line standards to be selected.



When the NTSCJ is enabled the encoder will produce an NTSCJ signal (an NTSC signal without pedestal)

Proc Amp

Note that for this and other screens the following applies:



The  symbol represents the Preset function and will return the function to the default setting.

The  and  symbols at the ends of the scroll bar allow the value to be adjusted in discrete steps.

The numerical value will be shown above the scroll bars and selecting Preset  will return the setting to the calibrated value of 0 for items on this screen.

This screen will allow the settings of the Chroma Gain, Black Level, NTSC Hue, Luma Gain, Y/C Timing and Picture position to be adjusted. AGC and ACC may also be enabled.

Luminance Gain

This item allows the gain of the luminance signal to be adjusted.

By using the scroll bar the gain may be adjusted by ± 3 dB in steps of 0.1 dB.

Black Level

This item allows the Y pedestal or black level to be adjusted.

By using the scroll bar the pedestal may be adjusted by ± 102.4 mV in steps of 1.6 mV.

Chroma Gain

This item allows the gain of the chrominance signal to be adjusted.

By using the scroll bar the gain may be adjusted by ± 3 dB in steps of 0.1 dB.

Timing

Timing Enable

Selecting this item will enable the Picture Position and YC Timing functions.

Picture Position

This item allows the timing of the picture position relative to the normal value, to be adjusted.

By using the scroll bar the timing may be adjusted by ± 1036 ns in 148 ns steps

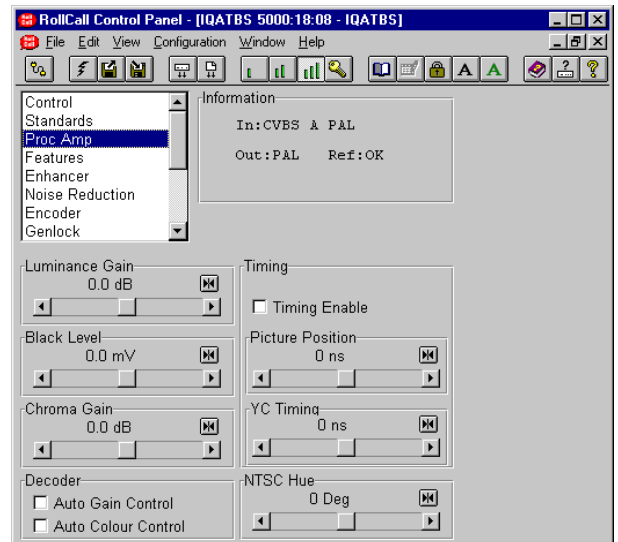

YC Timing

This item allows the timing of the chrominance signal relative to the luminance signal to be adjusted, (i.e. Y to Cb/Cr timing) in nanoseconds. By using the scroll bar the timing may be adjusted by ± 1036 ns in 148 ns steps.

NTSC Hue

This item allows the Hue of NTSC signals to be adjusted. By using the scroll bar the Hue may be adjusted by 360° in steps of 1° .

Decoder

This function allows automatic level controls to be enabled.

Auto gain Control

When this item is enabled the luminance gain will vary relative to the input peak white amplitude.

This will maintain the output signal at a normalised level even though the input signal level may be above or below standard level.

The control will be effective over an input level range of +3 dB to -6 dB.

Auto Color Control

When this item is enabled the chrominance gain will vary relative to the input burst amplitude. This will maintain correct color saturation regardless of changes in subcarrier amplitude.

Features

PAL Line 23

Process As Video

When enabled line 23 of the PAL input signal will be processed as active picture and the ProcAmp controls will effect Line 23.

Pass Line 23

When selected the first half line of line 23 is passed unprocessed, the second half line is blanked and the ProcAmp controls will not effect Line 23.

Blank Line 23

When enabled line 23 of the PAL input signal will be blanked.

NTSC Line 21 & 283

This item allows various options to be applied to line 21 and line 283 of an NTSC signal.

Process As Video

When enabled line 21/283 of the NTSC input signal will be processed and the ProcAmp controls will effect Line 21/283.

Pass Line 21/283

When selected lines 21/283 are passed unprocessed and the ProcAmp controls will not effect Line 21/283.

Blank Line 21/283

When enabled line 21/283 of the NTSC input signal will be blanked.

Note that the first half of line 283 on the composite (NTSC) output is always blanked.

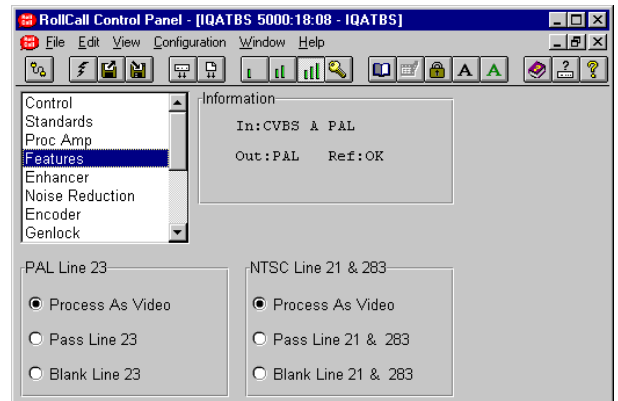

Enhancer

Enhance Enable

Selecting this item will enable the enhance function.

Horizontal Enhance Level

This function allows Horizontal enhancement to be applied to the processed signal. The non-linear process prevents enhancement of low amplitude signals typical of noise.

The level of enhancement may set to De (de-enhance), Low, medium and High. Preset is to Low.

Note that the De selection will de-enhance the signal. This setting is useful when processing signals that may have been previously over-enhanced.

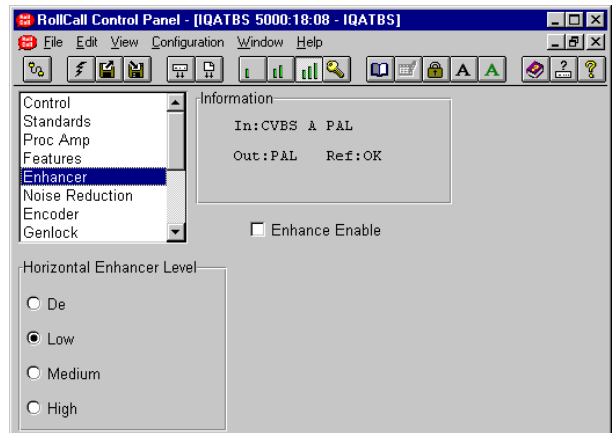

Noise Reduction

Noise Reduction Enable

Selecting this item will enable the Noise Reduction function.

Y Noise Reduce

This item allows Recursive noise reduction to be applied to the luminance channel.

The range of level adjustment is Off, low, medium and high. Preset is to Low.

C Noise Reduce

This item allows Recursive noise reduction to be applied to the Chrominance channel.

The range of level adjustment is Off, low, medium and high. Preset is to Low.

Split Screen

To enable the effects of noise reduction to be easily seen this function allows the screen to be split into 2 halves either left/right or top/bottom. One half will show the picture with noise reduction and the other half without noise reduction.

Off

This will disable the split screen function.

Left Right

When enabled the screen will be split into two equal sections separated by a vertical white line. The processed picture will occupy the right hand section of the screen and the unprocessed picture will occupy the left hand side section.

Top Bottom

When enabled the screen will be split into two equal sections separated by a horizontal white line. The processed picture will occupy the bottom section of the screen and the unprocessed picture will occupy the top section.

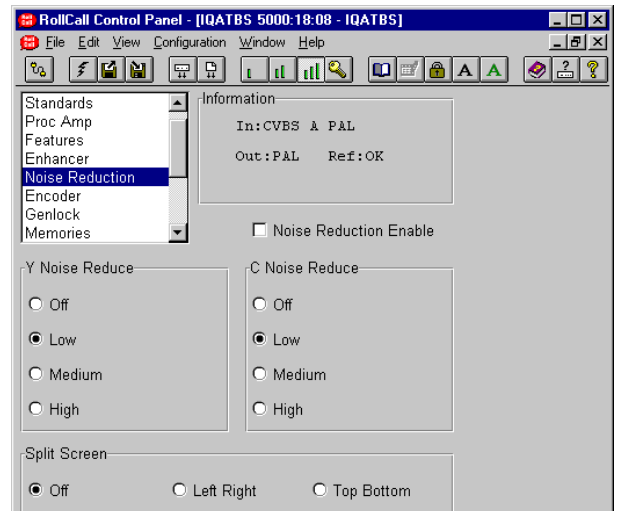

Encoder

This screen allows various parameters of the encoding section to be set up.

Encoder Options

VITS Insert

When this function is selected VITS lines for the operating line standard are inserted in the vertical blanking interval.

Pass Vertical Data

When selected (text reversed) the decoder will pass data (unblanked) present in the vertical blanking interval, to the output.

When de-selected (text normal) all data in the vertical blanking interval will be blanked.

SECAM Options

This function allows options to a SECAM signal to be selected.

Notch Filter Disable

When selected the SECAM luminance notch filter will be disabled.

Preset is to Filter enabled.

Bottles Enable

This function allows the SECAM-V color ident signal (Bottles) to be switched ON (selected) or OFF (not selected).

Preset is to Bottles disabled.

Carrier Disable

This function allows the chrominance carrier to be switched ON (not selected) or OFF (selected)

Preset is to Carrier enabled

Chroma Filter Disable

This function allows the chrominance filter to be switched ON (not selected) or OFF (selected).

Preset is to Filter enabled.

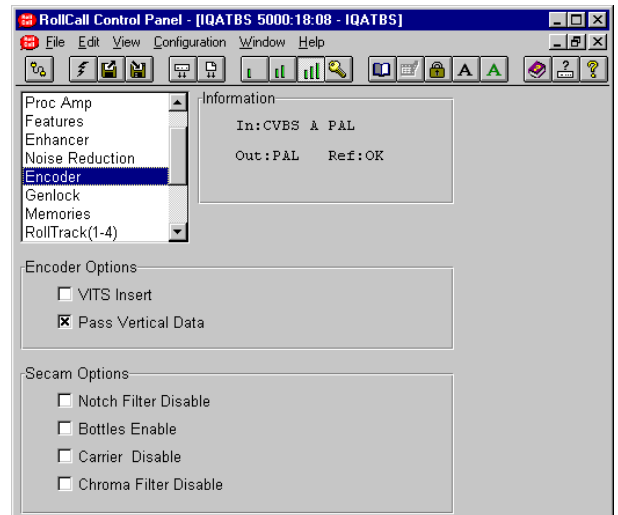

Genlock

Genlock

When enabled the unit will lock to an incoming valid reference signal with parameters set using this screen. When not enabled the output signal will be free-running. In this mode the frequency accuracy will be ± 10 ppm.

Mode

Two modes of locking to the reference signal may be selected.

SCH The unit will lock to the Line, Field and subcarrier signals of the reference signal.

HV The unit will only lock to the Line and Field signals of the reference signal. Note that the **Genlock SC Phase** controls may be adjusted but the settings will be irrelevant in this mode.

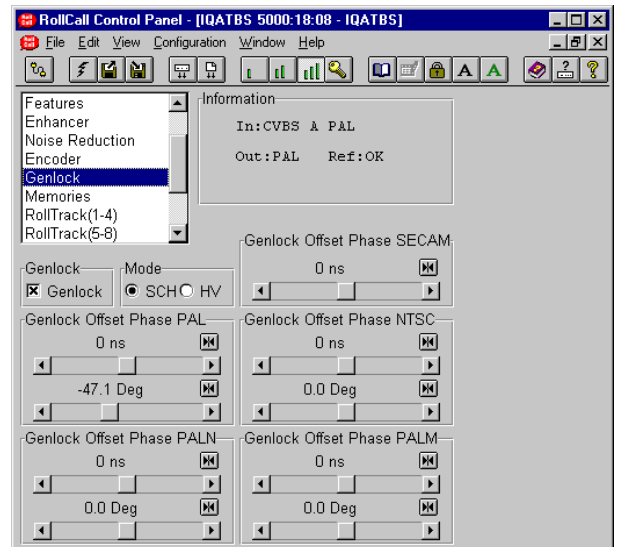

Genlock Offset Phase PAL

This item allows adjustment of the horizontal timing of the output signal relative to the reference sync signal, in nanoseconds.

The range is approximately $\pm 113 \mu\text{s}$ in steps of one cycle of subcarrier (225 ns). (This ensures the correct SC/H timing is maintained)

Selecting Preset returns the setting to zero. (Output coincident with reference)

Genlock Offset Phase PALN

This item allows adjustment of the horizontal timing of the output signal relative to the reference sync signal, in nanoseconds.

The range is approximately $\pm 113 \mu\text{s}$ in steps of one cycle of subcarrier (279 ns). (This ensures the correct SC/H timing is maintained)

Selecting Preset returns the setting to zero. (Output coincident with reference)

Genlock (continued)

Genlock Offset Phase SECAM

This item allows adjustment of the horizontal timing of the output signal relative to the reference sync signal, in nanoseconds.

The range is approximately $\pm 37 \mu\text{s}$ in steps of 74 ns.

Selecting Preset returns the setting to zero. (Output coincident with reference)

Genlock Offset Phase NTSC

This item allows adjustment of the horizontal timing of the output signal relative to the reference sync signal, in nanoseconds.

The range is approximately $\pm 113 \mu\text{s}$ in steps of one cycle of subcarrier (279 ns). (This ensures the correct SC/H timing is maintained)

Selecting Preset returns the setting to zero. (Output coincident with reference)

Genlock Offset Phase PALM

This item allows adjustment of the horizontal timing of the output signal relative to the reference sync signal, in nanoseconds.

The range is approximately $\pm 113 \mu\text{s}$ in steps of one cycle of subcarrier (279 ns). (This ensures the correct SC/H timing is maintained)

Selecting Preset returns the setting to zero. (Output coincident with reference)

Genlock SC Phase (Deg Scroll Bars)

This function allows the relative phasing between the reference subcarrier and the output signal subcarrier to be adjusted.

The range of adjustment is 359.9° (continuously adjustable) in steps of 0.1° and the preset value is 0° (Output coincident with reference)

Note that the Preset Unit function in the Memories and Logging and Preset screen will not change this setting.

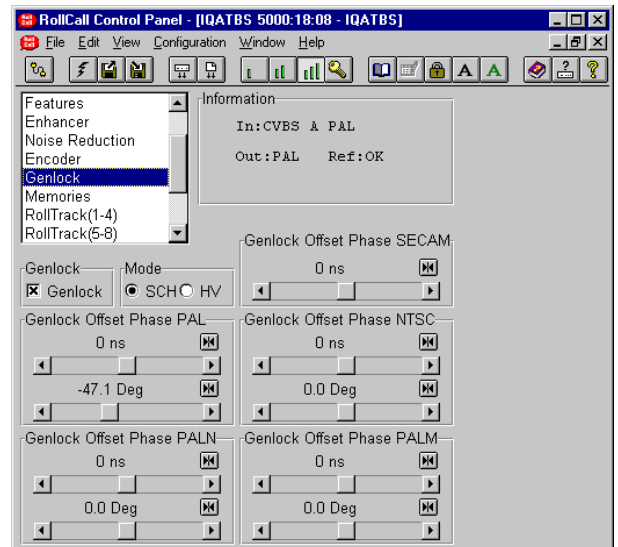

Memories

This function allows a number of particular setups of the IQATBS to be saved and recalled. There are 8 memory locations available.

To change the memory name, type the new name in the text area and then select  (return)

The  symbol represents the Preset function and will return the function to the default name.



This item allows the memory location to be cleared and returned to the default (preset) setting.



This function allows the settings of all items to be saved at the memory location.



This function allows the settings saved at the memory location to be recalled.



Selecting this item sets all adjustment functions that include a preset facility, to their preset values. *Note that this function will not change any genlock phase adjustment settings.*

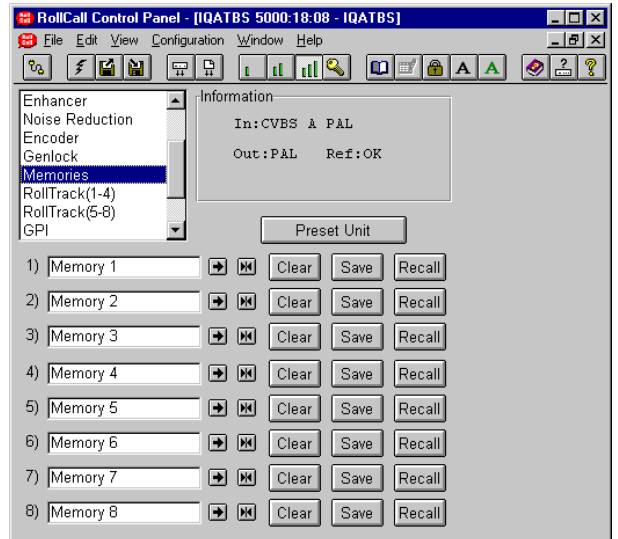

RollTrack 1-4
RollTrack 5-8

This function allows the value of the delay time produced by this module to be sent, via the RollCall™ network, to audio delay units connected on the same network. This enables compatible audio delay units to produce an audio delay dependent on this and other similar units. The audio delay unit will dynamically follow or track the received delay-time information allowing processed video signals to be timed correctly with audio signals. This automatic tracking system via the RollCall™ network is call **RollTrack**.

For more detailed information, see the RollTrack section (Appendix) at the end of this manual.

The destination for the delay information is set by the network code address as follows:

Unit 1-4 and Unit 5-8

This item allows the address of the selected destination unit to be set.

To change the address, type the new destination in the text area and then select  (return)

 (Preset) returns to the default destination

For details of the RollCall command numbers for specific units please contact your local Snell & Wilcox agent.

The full network address has five sets of numbers.

For example: 0000:10:01*14*51

The first set (0000) is the network segment code number

The second set (10) is the number identifying the (enclosure/mainframe) unit

The third set (01) is the slot number in the unit

The fourth set (14) separated by an * is the channel number.

Note that only channel numbers 14, 15, 16 & 17 should be used for audio delay cards.

The fifth set (51) is the board type identification.

Once a destination address for a unit has been set the OK function will return to the unit menu to allow another address to be set if required.

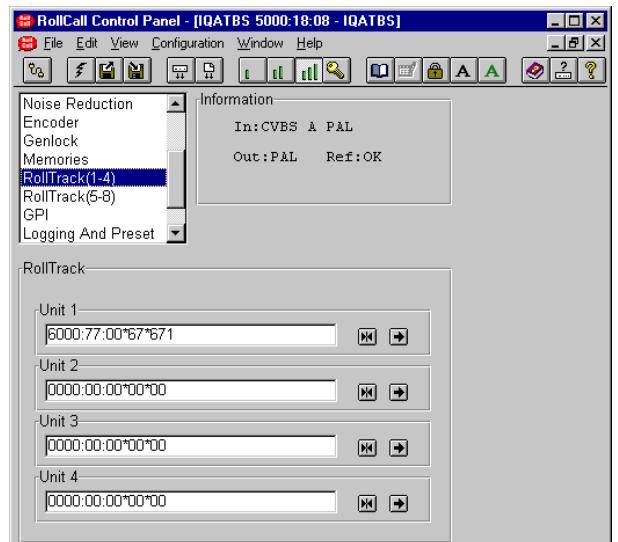

GPI

This screen allows the GPI to be configured as and its action defined.

GPI Input Setup

When configured as an input the GPI connection may be used for accepting GPI information (from mechanical switch contacts, relay contacts etc.) The resulting action that the unit takes may be selected using this item.

Input Enable

When selected the GPI connection will be configured as an input.

Note that this function will toggle with the Output Enable function.

GPI Input Open

This function determines what happens when the selected GPI input condition changes from closed to open.

Off	No action
Pattern On	The output will become the selected pattern signal.
Pattern Off	The output will become the normal output signal.
Freeze On	The output will become a frozen picture.
Freeze Off	The output will become unfrozen and return to normal.
Memory 1 to 8	The unit will revert to the setup stored in the selected memory location

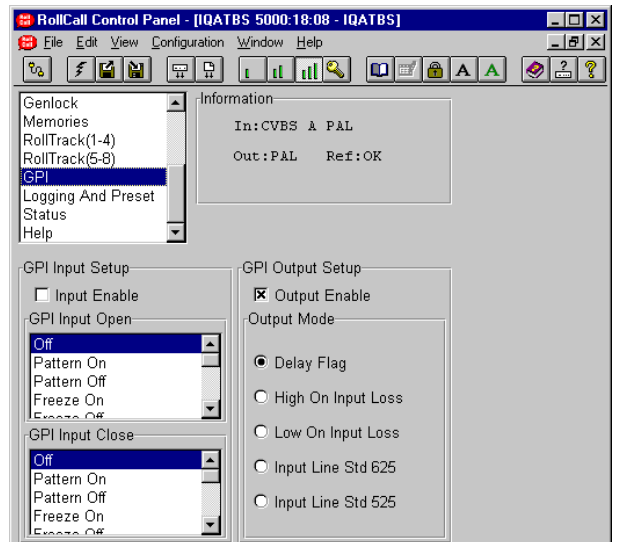

GPI Input Close

This function determines what happens when the selected GPI input condition changes from open to closed.

Off	No action
Pattern On	The output will become the selected pattern signal.
Pattern Off	The output will become the normal output signal.
Freeze On	The output will become a frozen picture.
Freeze Off	The output will become unfrozen and return to normal.
Memory 1 to 8	The unit will revert to the setup stored in the selected memory location

GPI (continued)

GPI Output Setup

This function allows the GPI connection to be configured as an output and its action defined.

Output Enable

When selected the GPI connection will be configured as an Output.

Note that this function will toggle with the Input Enable function.

Output Mode

When the GPI connection is configured as an Output this item allows the type of output signal to be selected.

Delay Flag

When enabled the output will go high representing the input/output time delay through the unit.

Input Loss

When enabled the output will change when a loss of the selected input signal occurs.

Input Loss Option

This item allows the polarity of the GPI output signal to be changed under input loss conditions.

High on Input Loss

When selected the GPI output will go high if the input signal is lost

Low on Input Loss

When selected the GPI output will go low if the input signal is lost.

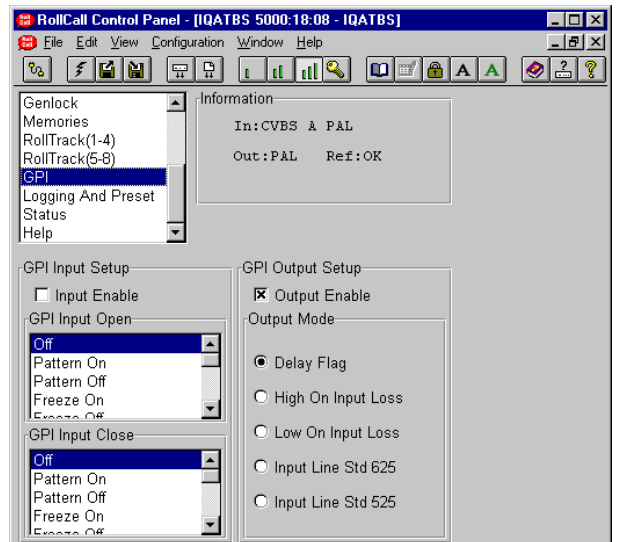

Logging And Preset

Logging

If a logging device is attached to the RollCall™ network, information about various parameters can be made available to such a device.

This screen allows information about the **Input State**, **Input Standard** and the **Reference State** to be made available for logging by selecting the appropriate box or boxes.

Preset Unit



Selecting this item sets all adjustment functions that include a preset facility, to their preset values.

Note that this function will not change any genlock phase adjustment settings.

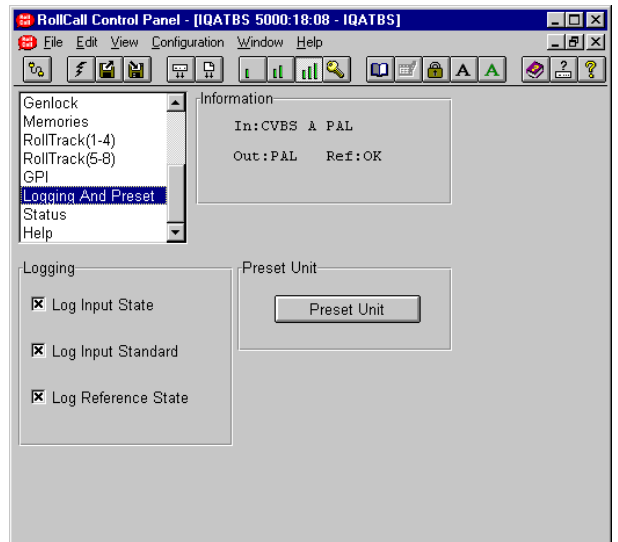

ROLLCALL LOG FIELDS

Log Field	Log Value	Description
INPUT=	LOST	No input signal.
	OK	Valid input signal
	LOST	Invalid input signal
STD=	<string> PAL	Input standard description.
	PAL_M	
	PAL_N	
	NTSC	
	NTSCJ	
	SECAM	
	N443	
	625	
	525	
	UNKNOWN	Input Lost
STDERR	Not a selected input standard	
EXTREF=	N/A	Genlock not selected.
	OK	Output same standard as Reference
	LOST	Reference lost or not same
SN=	<string>	Serial Number of unit.
FAULT=	FAIL:LOCAL_MODE	Module is in Local mode

Status

GPI Delay

This function will display the total video delay through the unit in milliseconds.

Software Version

This item shows the version of the software fitted in the module.

Serial Number

This item shows the serial number of the module.

Restart

This will reboot the unit simulating a power-down power-up cycle restoring power-up settings.

Display Information

This item allows the type of data that is displayed in the Information area to be chosen.

Default

When this item is selected the display window will show details about the Input Signal, Reference signal and the output as shown in the example below.

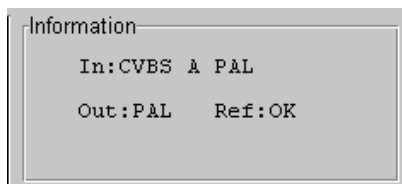

Status

When this item is selected the display window will show details about the Input Signal and some of the processing controls as shown in the example below.

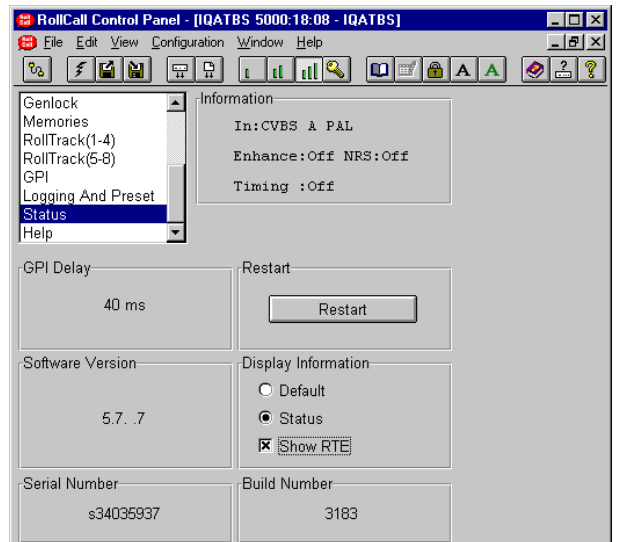
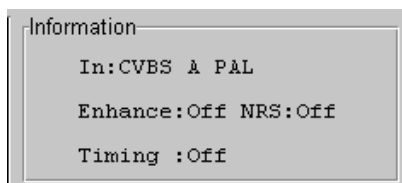

Show RTE (RollTrack Errors)

When this item is enabled an error message will appear in the information window if an acknowledgement is not received from the RollTrack destination controls as shown in the example below.

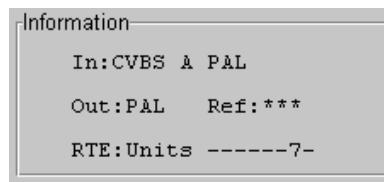

Build Number

This will indicate the factory build number. This number defines all parameters of the unit (software versions, build level etc.) for identification purposes.

Help

Information Window Definitions

This area will show abbreviated data about the status of the unit.

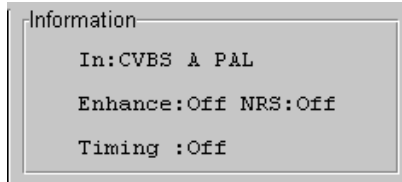

Abbreviations used are as follows:

First Line

Item 1: **In** (Input Selection)

In: CVBS A Composite input A selected.
 In: CVBS B Composite input B selected.
 In: YC YC input elected.

Item 2: Detected input signal standard

*** No input or invalid signal detected
 525 Input is a 525 line monochrome signal
 625 Input is a 625 line monochrome signal
 PAL Input is a PAL composite signal
 PALN Input is a PAL-N composite signal
 SECAM Input is a SECAM composite signal
 NTSC Input is a NTSC composite signal
 NTSCJ Input is a NTSCJ composite signal
 PALM Input is a PAL-M composite signal

Second Line

Item 1 **Out:** (*Encoder output signal standard*)

PAL Output is a PAL composite signal
 PAL-N Output is a PAL-N composite signal
 SECAM Output is a SECAM composite signal
 NTSC Output is a NTSC composite signal
 NTSCJ Output is a NTSCJ compositesignal
 PAL-M Output is a PAL-M composite signal

Item 2 **Ref:** (*Reference signal information*)

OK Reference signal is valid the unit is genlocked.
 Error A reference signal error or no reference has been detected while trying to genlock.
 *** No reference or invalid reference
 Off Genlock is Off

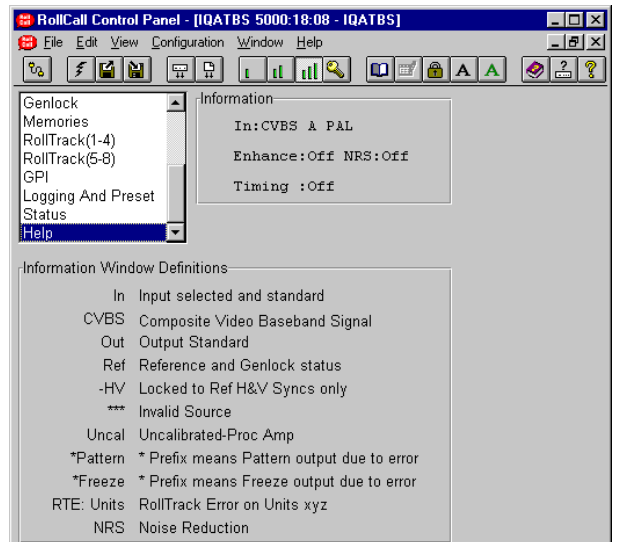

Third Line

The third line will show the status of the output signal and the state of the ProcAmp controls.

Item 1 (Output Signal)

(Nothing) Output is processed picture.
 Pattern Output is a pattern
 Freeze Output is a frozen picture

Note that if Pattern or Freeze has been forced because of an input signal failure the words will be prefixed by an asterisk e.g ***Pattern** or ***Freeze**.

Item 2 (ProcAmp Controls)

The word **Uncal** will displayed if the ProcAmp controls are not at their preset values.

IQATBS RollCall Commands

User Level

Command No.		Command Name	Values
Hex	Dec		
0001	1	Serial Number	Static Display (no control)
0002	2	Software Version	Static Display (no control)
0003	3	<Logging>	1=Preset Unit
0009	9	<Input Select>	0=Composite A 1=Composite B 2=YC
0018	24	<Pattern>	0=Black 1=75% Colour Bars 2=100% Colour Bars 3=MultiBurst
0021	33	Pattern Enable	clear=0 set=1 (toggle=2)
0027	39	Genlock Enable	clear=0 set=1 (toggle=2)
0028	40	Freeze	clear=0 set=1 (toggle=2)
0029	41	Y NR Enable	clear=0 set=1 (toggle=2)
002A	42	C NR Enable	clear=0 set=1 (toggle=2)
002D	45	Enhancer Enable	clear=0 set=1 (toggle=2)
0034	52	<Split Screen>	0=Split Screen Off 1=Top Bottom 2=Left Right
0037	55	<Memory Read>	1=Memory 1 2=Memory 2 3=Memory 3 4=Memory 4 5=Memory 5 6=Memory 6 7=Memory 7 8=Memory 8
0047	71	RollTrack Errors	clear=0 set=1 (toggle=2)
0074	116	<Status Display>	0=Default Display 1=Status Display
0075	117	GPI Delay	Static Display (no control)
0078	120	Build Number	Static Display (no control)
007B	123	Noise Reduce Enable	clear=0 set=1 (toggle=2)

Engineering Level

Command No.		Command Name	Values
Hex	Dec		
0001	1	Serial Number	Static Display (no control)
0002	2	Software Version	Static Display (no control)
0003	3	<Logging>	1=Preset Unit
0004	4	<Status Display>	1=Restart
0009	9	<Input Select>	0=Composite A 1=Composite B 2=YC
000A	10	Input Standard PAL	clear=0 set=1 (toggle=2)
000B	11	Input Standard NTSC	clear=0 set=1 (toggle=2)
000C	12	Input Standard PALN	clear=0 set=1 (toggle=2)
000D	13	Input Standard PALM	clear=0 set=1 (toggle=2)
000E	14	Input Standard SECAM	clear=0 set=1 (toggle=2)
000F	15	Input Standard NTSCJ	clear=0 set=1 (toggle=2)
0010	16	Input Standard N4.43	clear=0 set=1 (toggle=2)
0011	17	Input Standard Mono 625	clear=0 set=1 (toggle=2)
0012	18	Input Standard Mono 525	clear=0 set=1 (toggle=2)
0013	19	<Output 625 Standards>	1=PAL 3=PALN 5=SECAM
0014	20	<Output 525 Standards>	2=NTSC 4=PALM 6=NTSCJ
0015	21	Auto Gain Control	clear=0 set=1 (toggle=2)
0016	22	Auto Chroma Control	clear=0 set=1 (toggle=2)
0017	23	<H Enhancer>	0=Off 1=H Enhancer Low 2=H Enhancer Medium 3=H Enhancer High
0018	24	<Pattern>	0=Black 1=75% Colour Bars 2=100% Colour Bars 3=MultiBurst
0019	25	<PAL Line 23>	0=Process As Video 1=Pass Line 23 2=Blank Line 23
001A	26	<NTSC Line 21 & 283>	0=Process As Video 1=Pass Line 21 & 283 2=Blank Line 21 & 283
001B	27	Log Reference State	clear=0 set=1 (toggle=2)
001C	28	Log Input State	clear=0 set=1 (toggle=2)
001D	29	Luminance Gain	min=-30 max=30 Step=1 Div=10 Units=dB
001E	30	Chroma Gain	min=-30 max=30 Step=1 Div=10 Units=dB
001F	31	Black Level	min=-1024 max=1024 Step=16 Div=10 Units=mV
0020	32	NTSC Hue	min=-180 max=179 Step=1
0021	33	Pattern Enable	clear=0 set=1 (toggle=2)
0022	34	<Y Level>	0=Y Off 1=Y Low 2=Y Medium 3=Y High
0023	35	<Default Output>	3=Pattern 4=Freeze 5=Input
0024	36	<C Level>	0=C OFF 1=C Low 2=C Medium 3=C High
0025	37	YC Timing	min=-1036 max=1036 Step=148
0026	38	Picture Position	min=-1036 max=1036 Step=148
0027	39	Genlock Enable	clear=0 set=1 (toggle=2)
0028	40	Freeze	clear=0 set=1 (toggle=2)
0029	41	Y NR Enable	clear=0 set=1 (toggle=2)
002A	42	C NR Enable	clear=0 set=1 (toggle=2)
002B	43	Pass Vertical Data	clear=0 set=1 (toggle=2)
002C	44	PAL Chroma Averager	clear=0 set=1 (toggle=2)
002D	45	Enhancer Enable	clear=0 set=1 (toggle=2)
002E	46	VITS Insert	clear=0 set=1 (toggle=2)
002F	47	Pass Vertical Data	clear=0 set=1 (toggle=2)
0030	48	Notch Disable	clear=0 set=1 (toggle=2)
0031	49	Bottles Enable	clear=0 set=1 (toggle=2)
0032	50	Carrier Disable	clear=0 set=1 (toggle=2)
0033	51	Chroma Filt Disable	clear=0 set=1 (toggle=2)
0034	52	<Split Screen>	0=Split Screen Off 1=Top Bottom 2=Left Right

```

0036 54 <Memory Save> 1=Memory 1 2=Memory 2 3=Memory 3 4=Memory 4
5=Memory 5 6=Memory 6 7=Memory 7 8=Memory 8
0037 55 <Memory Read> 1=Memory 1 2=Memory 2 3=Memory 3 4=Memory 4
5=Memory 5 6=Memory 6 7=Memory 7 8=Memory 8
0038 56 <Memory Clear> 1=Memory 1 2=Memory 2 3=Memory 3 4=Memory 4
5=Memory 5 6=Memory 6 7=Memory 7 8=Memory 8
0039 57 Name Memory 1 Edit String
003A 58 Name Memory 2 Edit String
003B 59 Name Memory 3 Edit String
003C 60 Name Memory 4 Edit String
003D 61 Name Memory 5 Edit String
003E 62 Name Memory 6 Edit String
003F 63 Name Memory 7 Edit String
0040 64 Name Memory 8 Edit String
0047 71 RollTrack Errors clear=0 set=1 (toggle=2)
0047 71 Show RollTrack Err clear=0 set=1 (toggle=2)
0048 72 RollTrack Unit 1 Edit String <Address>*<Command>*<ID>
0049 73 RollTrack Unit 2 Edit String <Address>*<Command>*<ID>
004A 74 RollTrack Unit 3 Edit String <Address>*<Command>*<ID>
004B 75 RollTrack Unit 4 Edit String <Address>*<Command>*<ID>
004C 76 RollTrack Unit 5 Edit String <Address>*<Command>*<ID>
004D 77 RollTrack Unit 6 Edit String <Address>*<Command>*<ID>
004E 78 RollTrack Unit 7 Edit String <Address>*<Command>*<ID>
004F 79 RollTrack Unit 8 Edit String <Address>*<Command>*<ID>
0051 81 <GPI Open> 0=Off 1=Memory 1 2=Memory 2 3=Memory 3
4=Memory 4 5=Memory 5 6=Memory 6 7=Memory 7
8=Memory 8 9=Freeze On 10=Freeze Off 11=Pattern On
12=Pattern Off
0052 82 <GPI Close> 0=Off 1=Memory 1 2=Memory 2 3=Memory 3
4=Memory 4 5=Memory 5 6=Memory 6 7=Memory 7
8=Memory 8 9=Freeze On 10=Freeze Off 11=Pattern On
12=Pattern Off
0053 83 GPI Input Enable clear=0 set=1 (toggle=2)
0054 84 GPI Output Enable clear=0 set=1 (toggle=2)
0057 87 PAL H Phase min=-505 max=505 Step=1
0058 88 NTSC H Phase min=-410 max=410 Step=1
0059 89 PALN H Phase min=-408 max=408 Step=1
005A 90 PALM H Phase min=-409 max=409 Step=1
005B 91 SECAM H Phase min=-505 max=505 Step=1
005C 92 PAL SC Phase min=-1800 max=1799 Step=1 Div=10 Units=Deg
005D 93 NTSC SC Phase min=-1800 max=1799 Step=1 Div=10 Units=Deg
005E 94 PALN SC Phase min=-1800 max=1799 Step=1 Div=10 Units=Deg
005F 95 PALM SC Phase min=-1800 max=1799 Step=1 Div=10 Units=Deg
0073 115 <GPI Output Setup> 0=Delay Flag 1=High On Input Loss 2=Low On Input Loss
3=Input Line Std 625 4=Input Line Std 525
0074 116 <Status Display> 0=Default Display 1=Status Display
0075 117 GPI Delay Static Display (no control)
0076 118 Timing Enable clear=0 set=1 (toggle=2)
0078 120 Build Number Static Display (no control)
0079 121 <V Enhancer> 0=Off 1=V Enhancer Low 2=V Enhancer Medium
3=V Enhancer High
007A 122 <H Enhancer> 0=Frequency 2.25MHz 1=Frequency 3.375MHz
007B 123 Noise Reduce Enable clear=0 set=1 (toggle=2)
0082 130 Log Input Standard clear=0 set=1 (toggle=2)
0084 132 <Genlock Mode> 0=SCH Genlock 1=HV Sync Lock
0085 133 Stable Input clear=0 set=1 (toggle=2)

```

Supervisor Level

Command No. Hex	Dec	Command Name	Values
0001	1	Serial Number	Static Display (no control)
0002	2	Software Version	Static Display (no control)
0003	3	<Logging>	1=Preset Unit
0004	4	<Status Display>	1=Restart
0009	9	<Input Select>	0=Composite A 1=Composite B 2=YC
000A	10	Input Standard PAL	clear=0 set=1 (toggle=2)
000B	11	Input Standard NTSC	clear=0 set=1 (toggle=2)
000C	12	Input Standard PALN	clear=0 set=1 (toggle=2)
000D	13	Input Standard PALM	clear=0 set=1 (toggle=2)
000E	14	Input Standard SECAM	clear=0 set=1 (toggle=2)
000F	15	Input Standard NTSCJ	clear=0 set=1 (toggle=2)
0010	16	Input Standard N4.43	clear=0 set=1 (toggle=2)
0011	17	Input Standard Mono 625	clear=0 set=1 (toggle=2)
0012	18	Input Standard Mono 525	clear=0 set=1 (toggle=2)
0013	19	<Output 625 Standards>	1=PAL 3=PALN 5=SECAM
0014	20	<Output 525 Standards>	2=NTSC 4=PALM 6=NTSCJ
0015	21	Auto Gain Control	clear=0 set=1 (toggle=2)
0016	22	Auto Chroma Control	clear=0 set=1 (toggle=2)
0017	23	<H Enhancer>	0=Off 1=H Enhancer Low 2=H Enhancer Medium 3=H Enhancer High
0018	24	<Pattern>	0=Black 1=75% Colour Bars 2=100% Colour Bars 3=MultiBurst
0019	25	<PAL Line 23>	0=Process As Video 1=Pass Line 23 2=Blank Line 23
001A	26	<NTSC Line 21 & 283>	0=Process As Video 1=Pass Line 21 & 283 2=Blank Line 21 & 283
001B	27	Log Reference State	clear=0 set=1 (toggle=2)
001C	28	Log Input State	clear=0 set=1 (toggle=2)
001D	29	Luminance Gain	min=-30 max=30 Step=1 Div=10 Units=dB
001E	30	Chroma Gain	min=-30 max=30 Step=1 Div=10 Units=dB
001F	31	Black Level	min=-1024 max=1024 Step=16 Div=10 Units=mV
0020	32	NTSC Hue	min=-180 max=179 Step=1
0021	33	Pattern Enable	clear=0 set=1 (toggle=2)
0022	34	<Y Level>	0=Y Off 1=Y Low 2=Y Medium 3=Y High
0023	35	<Default Output>	3=Pattern 4=Freeze 5=Input
0024	36	<C Level>	0=C OFF 1=C Low 2=C Medium 3=C High
0025	37	YC Timing	min=-1036 max=1036 Step=148
0026	38	Picture Position	min=-1036 max=1036 Step=148
0027	39	Genlock Enable	clear=0 set=1 (toggle=2)
0028	40	Freeze	clear=0 set=1 (toggle=2)
0029	41	Y NR Enable	clear=0 set=1 (toggle=2)
002A	42	C NR Enable	clear=0 set=1 (toggle=2)
002B	43	Pass Vertical Data	clear=0 set=1 (toggle=2)
002C	44	PAL Chroma Averager	clear=0 set=1 (toggle=2)
002D	45	Enhancer Enable	clear=0 set=1 (toggle=2)
002E	46	VITS Insert	clear=0 set=1 (toggle=2)
002F	47	Pass Vertical Data	clear=0 set=1 (toggle=2)
0030	48	Notch Disable	clear=0 set=1 (toggle=2)
0031	49	Bottles Enable	clear=0 set=1 (toggle=2)
0032	50	Carrier Disable	clear=0 set=1 (toggle=2)
0033	51	Chroma Filt Disable	clear=0 set=1 (toggle=2)
0034	52	<Split Screen>	0=Split Screen Off 1=Top Bottom 2=Left Right
0036	54	<Memory Save>	1=Memory 1 2=Memory 2 3=Memory 3 4=Memory 4 5=Memory 5 6=Memory 6 7=Memory 7 8=Memory 8
0037	55	<Memory Read>	1=Memory 1 2=Memory 2 3=Memory 3 4=Memory 4 5=Memory 5 6=Memory 6 7=Memory 7 8=Memory 8
0038	56	<Memory Clear>	1=Memory 1 2=Memory 2 3=Memory 3 4=Memory 4 5=Memory 5 6=Memory 6 7=Memory 7 8=Memory 8
0039	57	Name Memory 1	Edit String
003A	58	Name Memory 2	Edit String
003B	59	Name Memory 3	Edit String
003C	60	Name Memory 4	Edit String
003D	61	Name Memory 5	Edit String
003E	62	Name Memory 6	Edit String
003F	63	Name Memory 7	Edit String
0040	64	Name Memory 8	Edit String
0047	71	RollTrack Errors	clear=0 set=1 (toggle=2)
0047	71	Show RollTrack Err	clear=0 set=1 (toggle=2)
0048	72	RollTrack Unit 1	Edit String <Address>*<Command>*<ID>
0049	73	RollTrack Unit 2	Edit String <Address>*<Command>*<ID>
004A	74	RollTrack Unit 3	Edit String <Address>*<Command>*<ID>
004B	75	RollTrack Unit 4	Edit String <Address>*<Command>*<ID>
004C	76	RollTrack Unit 5	Edit String <Address>*<Command>*<ID>
004D	77	RollTrack Unit 6	Edit String <Address>*<Command>*<ID>
004E	78	RollTrack Unit 7	Edit String <Address>*<Command>*<ID>
004F	79	RollTrack Unit 8	Edit String <Address>*<Command>*<ID>
0051	81	<GPI Open>	0=Off 1=Memory 1 2=Memory 2 3=Memory 3 4=Memory 4 5=Memory 5 6=Memory 6 7=Memory 7 8=Memory 8 9=Freeze On 10=Freeze Off 11=Pattern On 12=Pattern Off

```

0052      82 <GPI Close>          0=Off          1=Memory 1     2=Memory 2     3=Memory 3
                                     4=Memory 4     5=Memory 5     6=Memory 6     7=Memory 7
                                     8=Memory 8     9=Freeze On   10=Freeze Off  11=Pattern On
                                     12=Pattern Off
0053      83 GPI Input Enable      clear=0 set=1 (toggle=2)
0054      84 GPI Output Enable     clear=0 set=1 (toggle=2)
0057      87 PAL H Phase          min=-505 max=505 Step=1
0058      88 NTSC H Phase        min=-410 max=410 Step=1
0059      89 PALN H Phase        min=-408 max=408 Step=1
005A      90 PALM H Phase        min=-409 max=409 Step=1
005B      91 SECAM H Phase       min=-505 max=505 Step=1
005C      92 PAL SC Phase        min=-1800 max=1799 Step=1 Div=10 Units=Deg
005D      93 NTSC SC Phase       min=-1800 max=1799 Step=1 Div=10 Units=Deg
005E      94 PALN SC Phase       min=-1800 max=1799 Step=1 Div=10 Units=Deg
005F      95 PALM SC Phase       min=-1800 max=1799 Step=1 Div=10 Units=Deg
0073      115 <GPI Output Setup>  0=Delay Flag  1=High On Input Loss  2=Low On Input Loss
                                     3=Input Line Std 625
                                     4=Input Line Std 525
0074      116 <Status Display>    0=Default Display  1=Status Display
0075      117 GPI Delay          Static Display (no control)
0076      118 Timing Enable      clear=0 set=1 (toggle=2)
0078      120 Build Number       Static Display (no control)
0079      121 <V Enhancer>       0=Off          1=V Enhancer Low  2=V Enhancer Medium
                                     3=V Enhancer High
007A      122 <H Enhancer>       0=Frequency 2.25MHz  1=Frequency 3.375MHz
007B      123 Noise Reduce Enable clear=0 set=1 (toggle=2)
0082      130 Log Input Standard clear=0 set=1 (toggle=2)
0084      132 <Genlock Mode>     0=SCH Genlock  1=HV Sync Lock
0085      133 Stable Input      clear=0 set=1 (toggle=2)

```

