



---

# User Instruction Manual

## **IQSYN22**

HD/SD-SDI Frame Synchronizer with RGB Legalizer, Enhancer and SMPTE 2016 AFD Inserter

# Information and Notices

## Copyright and Disclaimer

Copyright protection claimed includes all forms and matters of copyrightable material and information now allowed by statutory or judicial law or hereinafter granted, including without limitation, material generated from the software programs which are displayed on the screen such as icons, screen display looks etc.

Information in this manual and software are subject to change without notice and does not represent a commitment on the part of Snell Limited. The software described in this manual is furnished under a license agreement and can not be reproduced or copied in any manner without prior agreement with Snell Limited. or their authorized agents.

Reproduction or disassembly of embedded computer programs or algorithms prohibited.

No part of this publication can be transmitted or reproduced in any form or by any means, electronic or mechanical, including photocopy, recording or any information storage and retrieval system, without permission being granted, in writing, by the publishers or their authorized agents.

Snell operates a policy of continuous improvement and development. Snell reserves the right to make changes and improvements to any of the products described in this document without prior notice.

## Contact Details

### Customer Support

<b>United Kingdom (HQ)</b> +44 (0) 118 921 4214 (tel) +44 (0) 118 921 4268 (fax) customersupport@snellgroup.com	
<b>Regional Support Contacts</b>	
<b>Snell USA</b> +1 818 556 2616 (tel) +1 818 556 2626 (fax) support.us@snellgroup.com	<b>Snell Germany</b> +49 (0) 6122 98 43 0 (tel) +49 (0) 6122 98 43 44 (fax) support.germany@snellgroup.com
<b>Snell Spain</b> +34 91 446 23 07 (tel) +34 91 446 17 74 (fax) support.spain@snellgroup.com	<b>Snell France</b> +33 1 41 95 30 50 (tel) +33 1 41 95 30 51 (fax) support.france@snellgroup.com
<b>Snell Asia Pacific</b> +852 2356 1660 (tel) +852 2575 1690 (fax) support.hk@snellgroup.com	<b>Snell India</b> +91 124 462 6000 (tel) +91 124 437 5888 (fax) support.india@snellgroup.com
<b>Snell Russia</b> +7 499 248 3443 (tel) +7 499 248 1104 (fax) support.russia@snellgroup.com	<b>Snell China</b> +86 10 6515 6158 (tel) +86 10 6515 5659 (fax) support.china@snellgroup.com

For further details of our Regional Customer Support Offices, please visit the Snell website and navigate to Support/Customer Support Contacts.

<http://www.snellgroup.com/support/customer-support/customer-support/>

Customers with a support contract should call their personalized number, which can be found in their contract, and be ready to provide their contract number and details.

# Contents

- Information and Notices** ..... 2
- 1. Introduction** ..... 6
  - 1.1 Module Description ..... 6
  - 1.2 Order Codes ..... 6
  - 1.3 Rear Panel View ..... 7
  - 1.4 Enclosures ..... 8
    - 1.4.1 B-style Enclosure ..... 8
    - 1.4.2 A-style Enclosures ..... 8
  - 1.5 Features ..... 9
- 2. Technical Specification** ..... 10
- 3. Connections** ..... 13
  - 3.1 IQSYN2226-1A / IQSYN2227-2A / IQSYN2239-2A ..... 13
    - 3.1.1 SDI Inputs ..... 13
    - 3.1.2 SDI Outputs ..... 13
    - 3.1.3 Analog Reference Input ..... 13
    - 3.1.4 GPI ..... 13
- 4. Card Edge LEDs** ..... 14
- 5. Controlling the IQSYN22 from the RollCall Control Panel** ..... 15
  - 5.1 The Information Window ..... 15
    - 5.1.1 Video Status ..... 15
    - 5.1.2 Audio Status ..... 16
    - 5.1.3 Metadata Status ..... 16
  - 5.2 Video Input ..... 17
    - 5.2.1 Input Select ..... 17
    - 5.2.2 Input Backup ..... 17
    - 5.2.3 Input Loss If ..... 17
    - 5.2.4 Agile V-Lock ..... 18
    - 5.2.5 Valid Input Standards ..... 18
    - 5.2.6 CRC/EDH Errors ..... 18
  - 5.3 Input Backup ..... 19
    - 5.3.1 Enable Backup Input Switch ..... 19
    - 5.3.2 Priority / Reversion ..... 19
    - 5.3.3 Backup State Select ..... 20
    - 5.3.4 Master State Select ..... 20
    - 5.3.5 Input Select ..... 20
    - 5.3.6 Master (Inp 1) Carrier Detect Fail ..... 20
    - 5.3.7 Master (Inp 1) Invalid Standard ..... 20
    - 5.3.8 Master (Inp 1) Error ..... 21
    - 5.3.9 Master (Inp 1) Embedded Audio Fail ..... 21
    - 5.3.10 Backup (Inp 2) Carrier Detect Fail ..... 21
  - 5.4 Video Output ..... 22
    - 5.4.1 Output ..... 22
    - 5.4.2 Output Standard ..... 23
    - 5.4.3 Pattern ..... 23
    - 5.4.4 Default Output ..... 23
    - 5.4.5 ProcAmp ..... 24
    - 5.4.6 User Caption ..... 24
    - 5.4.7 Utilities ..... 24
  - 5.5 Picture Output ..... 25
    - 5.5.1 Luma Clipper ..... 25
    - 5.5.2 RGB Legalizer ..... 25
    - 5.5.3 Advanced H Enhance ..... 25

5.6 SMPTE2016	27
5.6.1 Read / Writer	27
5.6.2 Use Received AFD Line Number	27
5.6.3 Global Preset	27
5.6.4 Reader	27
5.6.5 Writer	28
5.6.6 Read / Write Mapping	28
5.7 Embedded Proc Amp Groups 1-2 and 3-4	29
5.7.1 Groups 1 to 4, Pairs 1 and 2 (Embed 1-8 L & R)	29
5.8 Audio Mixer	30
5.8.1 Audio Sources	30
5.8.2 Mixer	30
5.9 Embedded Routing Groups 1-2 and 3-4	31
5.9.1 Link L+R	31
5.10 Embed On/Off	32
5.10.1 Embedder Priority	32
5.10.2 Group/Channel Active	32
5.11 Embedded I/P Setup	33
5.11.1 Embedded Audio Input Names	33
5.12 Embedded O/P Setup	35
5.12.1 Embedded Audio Output Names	35
5.13 Video Delay/DolbyE/Genlock	36
5.13.1 Genlock	37
5.13.2 Delay Timing	38
5.13.3 Dolby E Timing	38
5.13.4 Dolby E Auto Line	39
5.14 Audio Delays	40
5.14.1 Audio Delay Select - A/B	41
5.14.2 Internal Video Delay	41
5.14.3 Smooth Delay Limit	41
5.14.4 Embed Delay 1 to 8	42
5.14.5 Reliable Audio Alignment - Use Cases	42
5.15 ANC Blank & Bridge	44
5.15.1 VBI/VANC Standard	44
5.15.2 Blank Lines	45
5.15.3 Input Ancillary	45
5.15.4 Ancillary Bridge	45
5.16 GPIO	46
5.16.1 GPIO 1 and GPIO 2	46
5.16.2 GPI 1 (Input) or GPI 2 (Input)	46
5.16.3 GPI 1 (Output) and GPI 2 (Output)	47
5.16.4 GPIO Input Pulse Width Timer	47
5.16.5 GPIO Interface Circuitry	48
5.17 Memory	49
5.17.1 Recall Memory	49
5.17.2 Save Memory	49
5.17.3 Last Recalled	49
5.17.4 Save Memory Name	50
5.18 RollTrack	51
5.18.1 Disable All	51
5.18.2 RollTrack Index	51
5.18.3 RollTrack Source	51
5.18.4 RollTrack Address	52
5.18.5 RollTrack Command	52
5.18.6 RollTrack Sending	53
5.18.7 RollTrack Status	53
5.19 Logging	54
5.19.1 Video Input Logging	54
5.19.2 In1/2 Aud State Logging	54
5.19.3 In1/2 Aud Type Logging	55

- 5.19.4 O/P Aud Level Logging . . . . . 55
- 5.19.5 O/P Aud State Logging . . . . . 56
- 5.19.6 O/P Aud Type Logging . . . . . 56
- 5.19.7 O/P Dolby E Logging . . . . . 56
- 5.19.8 Ref/Output Logging . . . . . 57
- 5.19.9 Misc. Logging . . . . . 57
- 5.19.10 Log Field Descriptions . . . . . 58
- 5.20 Setup . . . . . 60
  - 5.20.1 Default Settings . . . . . 60
  - 5.20.2 Factory Defaults . . . . . 60
  - 5.20.3 Restart . . . . . 60
- Appendix A. RollTrack Audio Delay Tracking . . . . . 61**
  - A.1 Products Featuring RollTrack™ . . . . . 61
  - A.2 Configuration: Single Video Unit and Single Audio Delay . . . . . 61
  - A.3 Configuration: Multiple Video Units and Audio Delays . . . . . 61
  - A.4 Configuration: Vertical Delay Cluster . . . . . 62
  - A.5 Configuration: Horizontal Delay Cluster . . . . . 62
  - A.6 Configuration: Matrix Delay Cluster . . . . . 63
    - A.6.1 Configuration: An Array of Matrix Clusters . . . . . 65
- Appendix B. Firewall . . . . . 67**
  - B.1 Introduction . . . . . 67
  - B.2 How a Firewall Equipped Product Behaves . . . . . 67
  - B.3 Why Use a Firewall? . . . . . 67
    - B.3.1 Using a Firewall at the Beginning of a Chain . . . . . 67
    - B.3.2 Using a Firewall to Protect MPEG Encoders . . . . . 67
  - B.4 How a Firewall is Tested . . . . . 67
  - B.5 Performance of Firewall Equipped Products Versus Genlock Mode . . . . . 68
  - B.6 When Firewall Protection is Not Provided . . . . . 68
    - B.6.1 Video . . . . . 68
    - B.6.2 Audio . . . . . 68
- Appendix C. Ancillary Passing . . . . . 69**
  - C.1 SMPTE 272M and 299M . . . . . 69
  - C.2 SMPTE 291M . . . . . 69
- Appendix D. Audio Processing Overview . . . . . 71**
  - D.1 Audio Processing Block Diagram . . . . . 71
  - D.2 Audio Processing – Control Panel Screens Associations . . . . . 71
  - D.3 SDI Demultiplexer . . . . . 72
  - D.4 Audio Delay Processor . . . . . 72
  - D.5 Tone Generator . . . . . 73
  - D.6 Mixers 1 to 4 . . . . . 73
  - D.7 Embedder ProcAmps . . . . . 74
  - D.8 SDI TX . . . . . 75
  - D.9 Dolby E Audio Handling . . . . . 75
- Appendix E. Dolby E . . . . . 76**
  - E.1 What is Dolby E? . . . . . 76
  - E.2 Dolby E and Metadata . . . . . 76
  - E.3 Dolby E Partner Program . . . . . 76
  - E.4 16- and 20-bit Dolby E . . . . . 76
  - E.5 Dolby Digital and AC3 . . . . . 77
  - E.6 Metadata . . . . . 77

# 1. Introduction

## 1.1 Module Description

The IQSYN22 provides synchronization for HD-SDI 1.5 Gbps or SD-SDI 270 Mbps signals with 16-channel embedded audio processing including automatic synchronization of Dolby E signals. Using agile synchronization that is router-switching-tolerant makes this module ideal for all HD/SD-SDI lines input applications. A video processing amplifier and legalizer provides complete control over the video levels, whilst a powerful enhancement feature allows picture detail to be sharpened. Audio processing features include automatic Dolby E re-alignment, PCM tracking audio delay, channel level routing and mixing. The IQSYN22 is also able to directly pass audio channel status information to handle upstream switching of SDI containing PCM and Dolby E embedded audio.

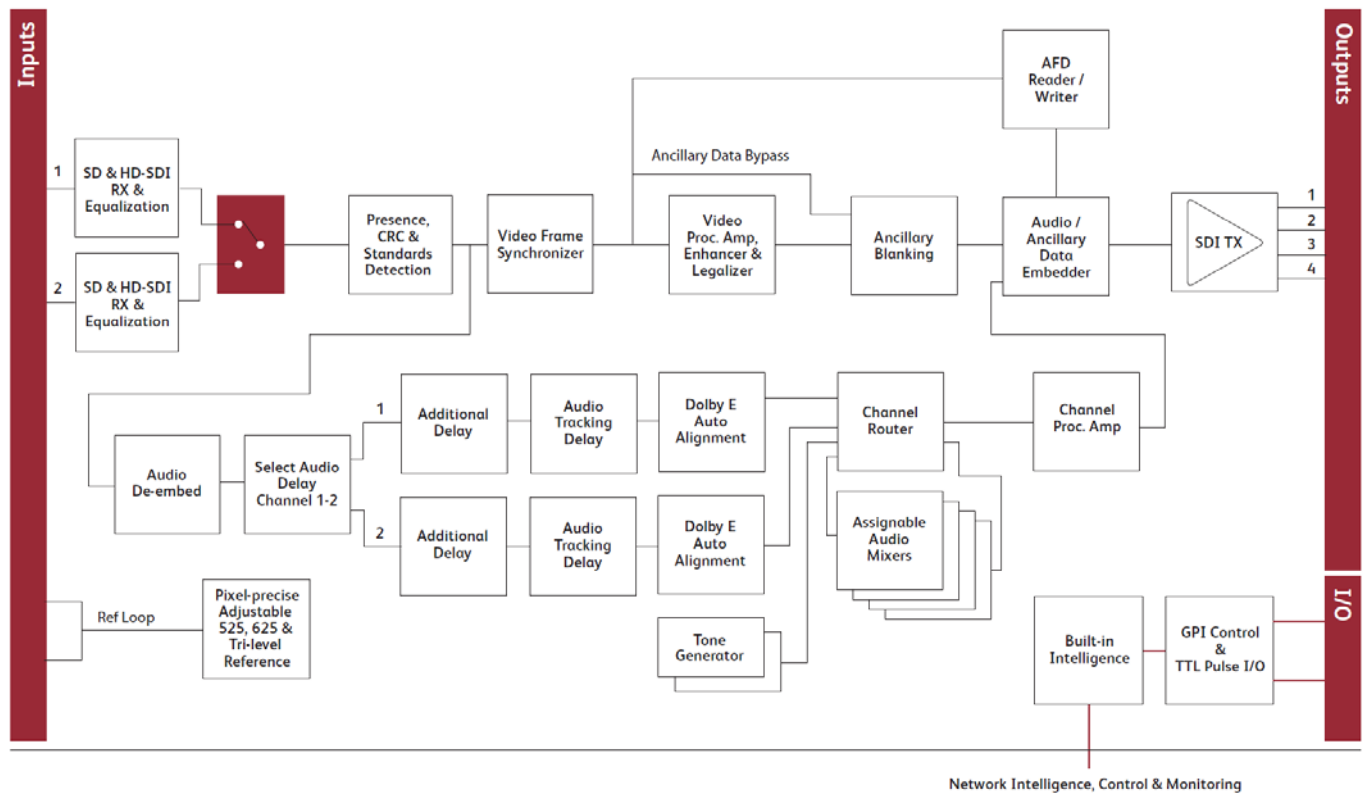

Block Diagram for IQSYN2227-2A

## 1.2 Order Codes

The following product order codes are covered by this manual:

- IQSYN2226-1A** HD-SDI and SD-SDI Synchronizer with RGB Legalizer and Enhancer. 3 outputs, 1 GPI.
- IQSYN2227-2A** HD-SDI and SD-SDI Synchronizer with RGB Legalizer and Enhancer. 4 outputs, 2GPIs.
- IQSYN2239-2A** HD-SDI and SD-SDI Synchronizer with RGB Legalizer and Enhancer and relay input bypass. 4 outputs, 2 GPIs.

### 1.3 Rear Panel View

The following rear panel types are available:

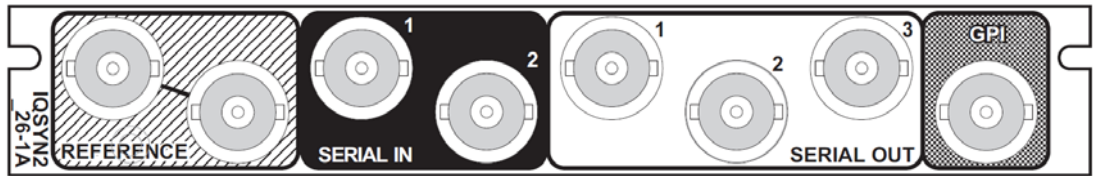

**IQSYN226-1A**

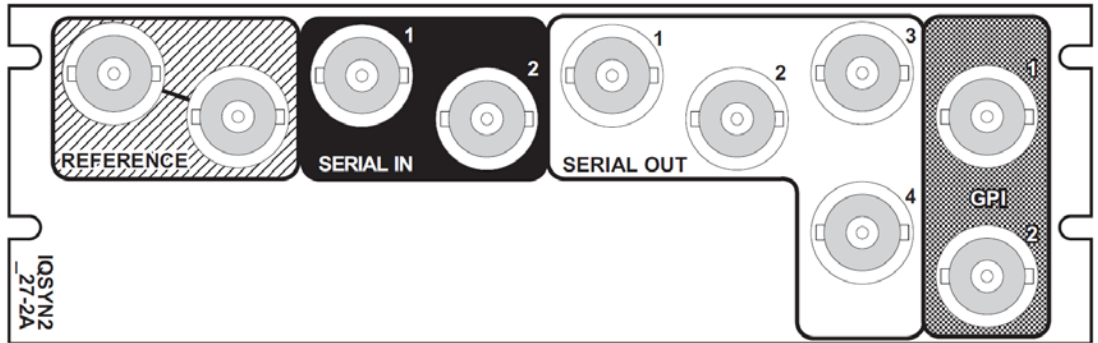

**IQSYN227-2A**

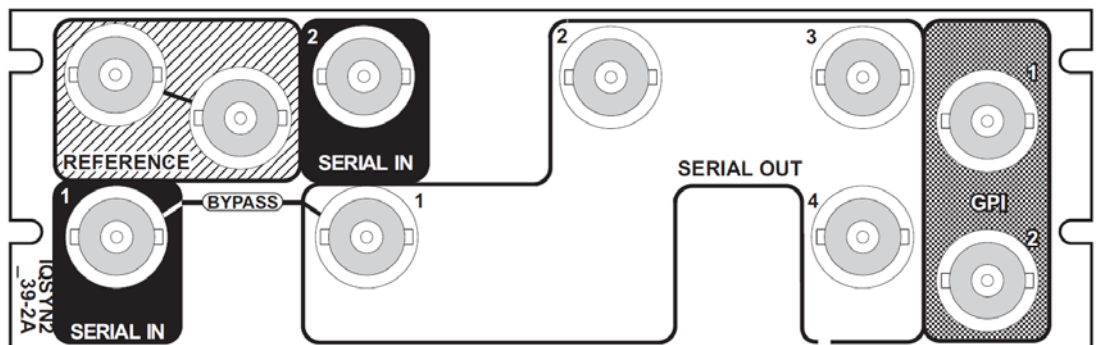

**IQSYN2239-2A**



## 1.4 Enclosures

The module can be fitted into the enclosure types shown.

**Important:** Although IQ modules are interchangeable between enclosures, their rear panels are enclosure specific. An IQH3B enclosure accepts modules with either “A” or “B” order codes. An IQH3A or IQH1A enclosure accepts modules with “A” order codes only.

### 1.4.1 B-style Enclosure



Enclosure order codes: IQH3B-S-0, IQH3B-S-P

### 1.4.2 A-style Enclosures



Enclosure order code: IQH1A-S-P



Enclosure order codes: IQH3A-S-0, IQH3A-S-P



Enclosure order codes: IQH3A-E-0, IQH3A-E-P, IQH3A-0-0, IQH3A-0-P



Enclosure order code: IQH1A-S-P



## 1.5 Features

- Agile HD/SD-SDI synchronizer with up to 11 frames of video delay and tracking audio delay
- Handles up to 16 channels of embedded audio present on the incoming SDI stream including ancillary cleaner for removal of unused ancillary data
- Embedded Dolby E support – pair routing and automatic re-alignment and synchronization to the video frame boundary
- Dual selectable HD/SD-SDI inputs with auto switching
- Agile synchronizer locking capable of handling mis-timed inputs of up to 5 lines without output video disturbance (SMPTE RP168 compliant)
- Standards supported:
  - HD-SDI to SMPTE292M/274M/296M
  - SD-SDI to SMPTE259M-C
- Capable of referencing to a bi-level or tri-level reference for HD timing
- Precision wide range genlock adjustment allowing you to time any HD/SD-SDI signal to pixel accuracy
- Video processing controls including hue, and advanced RGB gamut legalizer with selectable RGB area masks
- SMPTE 2016 reader, writer and re-mapper to insert user defined AFD metadata values in the output stream
- Advanced horizontal detail enhancer, with low, medium and high frequency band presets and custom gain and noise rejection controls
- Independent horizontal and vertical ancillary data blanking
- Tracking audio delay which seamlessly tracks the internal video delay and external RollTrack or GPI inputs
- 2 independent audio delay controllers including selectable fixed delay and RollTrack/GPI tracking delays for each (either selectable for eight pairs)
- Any group of embedded audio may be passed unchanged if not selected for processing or blanked
- Channel level (Sub-frame) routing
- 4 off 4 channel assignable audio mixers
- Audio processing amplifier and delay
- Built in Dolby E timing monitor allows accurate manual adjustment of Dolby E guard band position
- Input loss detection – input pass through/switch or black/pattern/freeze and Input SDI, CRC, EDH and ANC data checking and reporting
- Emergency input bypass option enables the SDI input signal to be passed through to SDI output 1 in the event of frame power failure or module removal

## 2. Technical Specification

<b>Inputs and Outputs</b>	
<b>Signal Inputs</b>	
SDI Inputs	2x HD/SD-SDI
Electrical	1.5 Gbps HD-SDI, SMPTE 292M 270 Mbps SDSDI, SMPTE 259M-C
Connector / Format	BNC / 75 Ohm panel jack on standard Snell connector panel
Input Cable Length	Up to 140 m Belden 1694A @ 1.5 Gbps (40 m input cable length and 35 m output cable length, relay bypass version. Belden 1694A @ 1.5 Gbps) Up to 275 m Belden 1694A @ 270 Mbps
<b>Note:</b> Specified cable lengths are a guide only. Exact cable length performance will depend on the quality of the cable used, the SDI video rate and the system setup. It is advisable not to cascade modules using the relay rear version although it may be possible if the interconnecting cable lengths are kept to an absolute minimum.	
Return Loss	>-15 dB
<b>Relay Bypass Versions</b>	
Input Return Loss	>-8 dB (When not in BYPASS mode)
Output Return Loss	>-8 dB (When not in BYPASS mode)
<b>Reference Input</b>	
Analog Reference Input	1 x Analog Reference with passive loop-through SMPTE 240/ 274M and RS170A
Electrical	Black (HD tri-level and SD bi-level) and Black Burst (SD bi-level) SD bi-level – RS170A, HD tri-level – SMPTE 240M, 274M and 296M
Connector / Format	BNC / 75 Ohm panel jack on standard Snell connector panel
Analog Reference Return Loss	SD bi-level > -40 dB to 5.5 MHz HD tri-level > -35 dB to 30 MHz
<b>Signal Outputs</b>	
SDI Outputs	3x / 4x HD/SD-SDI
Electrical	1.5 Gbps HD-SDI, SMPTE 292M 270 Mbps SDSDI, SMPTE 259M-C
Connector/Format	BNC / 75 Ohm panel jack on standard Snell connector panel
Return Loss	>-15 dB
<b>Control Interface</b>	
GPI	Up to 2x GPI (I/O configurable)
Electrical	TTL-compatible, active-low driven
Connector / Format	BNC / 75 Ohm panel jack on standard Snell connector panel
<b>Controls</b>	
<b>Indicators</b>	
Power	OK (Green)
CPU Running	OK (Green flashing)
FPGA Running	OK (Yellow flashing)
Status	OK (Green), Warning (Yellow), Error (Red)
Input 1	OK (Green), Loss (Off)
Input 2	OK (Green), Loss (Off)
SDI Err	Error (Red)
Reference Lock	OK (Green)
<b>Video Controls</b>	

Select Primary Input	1/2/Auto with user configurable rules
Output Standard	Select, Follow Input, Follow Reference
Standards List	Select video standards for automatic follow
Black Level	±200 mV in steps of 1 mV
Master Video Gain	±6 dB in steps of 0.1 dB
Y Gain	±6 dB in steps of 0.1 dB
Cb/Cr Gain	±6 dB in steps of 0.1 dB
Hue	-45° to +45°
RGB Legalizer	On/Off
RGB Legalizer Mask	700 mV, 721 mV, 735 mV presets
H enhancement	On/Off
H enhancement presets	Low, Medium, High, Super, Custom
H enhancement frequency	Low, Medium, High, Custom
Pattern Select	100% Color Bars, 75% Color Bars, SMPTE Bars, Tartan Bars, Black Field, Pluge Ramp, H Sweep, Pulse and Bar, Burst
Caption enable	Off / On
Caption generator	Programmable up to 16 characters
Caption size	X-Y adjust
Caption position	X-Y adjust
Blank Ancillary Data	Blank All, Blank HANC, Pass All, Pass when Output Standard equals Input Standard
VBI Line Blank	Individual lines for each video standard
Manual Freeze	On/Off
Freeze	Field/Frame
Video Channel Control	Mono, Y/C blank
Reference Select	External with phasing, Input Video with delay (Units: Lines and Pixels), Free-run
Delay Timing	Delay Frames
Default Video Output	Pattern / freeze / black / run through / redundant input
Auto Backup Rules	5 rules with Video presence and standard, Video Errors, Audio presence, GPI actions and Time Delays
<b>Audio Controls</b>	
Embedded Audio Types	PCM (to AES3)/Data (SMPTE 337M inc. Dolby E)/Mixed (Passes any channel status information present)
Channel Routing	Output channels routed from SDI (16 embedded channels from any group), test tone and silence
Output Side Control Proc.- Gain and Polarity	Independent Gain, Mute, and Polarity control over embedded output channels. +12 dB to -66 dB in 0.1 dB steps
Coarse Manual Delay 1 and 2	Up to +2 s in 0.25 ms steps, common to any selected pairs
Fine Manual Delay 1 and 2	Up to +0.25 ms in 5 µs steps, common to any selected pairs
Dolby E Delay (Alignment)	Auto/Manual
Variable Audio Delay 1 and 2	Up to 0.5 s from RollTrack + GPI Delay
Pair Based Delay Sources	Selectable video synchronizer delay + delay control 1 or 2
Embedder Priority	Normal distribution/audio prioritized
Embedded Group	Pass/Blank/Embed
Dolby E Auto Line Selection	Define Dolby E embed line for each video standard
Tone Setup	1 kHz, 2 kHz, 4 kHz, mute @ -20 dBFS or -18 dBFS

<b>Other Controls</b>	
GPI Configuration	Not Used, as an output, as an input, pulse width timer + invert
GPI Input	Activates on contact closure: Freeze, Pattern, Black, Blank ANC, Mono Y only, Mono CbCr only, Use I/P and Ext. reference, select I/P 1 and 2 and Backup
GPI Output	Produces an output for: Input 1 and 2 OK, Reference OK Freeze, Pattern, Black, Monochrome, Input 2 Selected
User memories	16x Save / Recall / Rename
Input/Output Names	User configurable naming of the individual embedded audio and mixer channels
<b>RollCall Features</b>	
Logging	Input Status, ANC, EDH, CRC Errors and standard, Reference Status and Standard Video output status and standard, Embedded audio input status and type (pairs 1-8), Embedded Dolby E output timing status (pairs 1-8)
RollTrack Controls	Source, Address, Command, Status, Sending
Roll Track Sources	Internal or detected device states that trigger the sending of RollTracks: Unused, Video Delay, Input Present /Input Loss, Reference OK / Loss, Output Freeze / Unfreeze, In 1/2 Select, GPI1/2 High / Low / Inactive, Embedded Audio Present/Loss (Pairs 1-8), Out (video standards)
<b>Specifications</b>	
Video Standards	750(720)/60p, 1125(1080)/30i 750(720)/59p, 1125(1080)/30sF 750(720)/50p, 1125(1080)/29i 1125(1080)/30p, 1125(1080)/29sF 1125(1080)/29p, 1125(1080)/25i 1125(1080)/25p, 1125(1080)/25sF 1125(1080)/24p, 1125(1080)/24sF 1125(1080)/23p, 1125(1080)/23sF 1125(1035)/30i 1125(1035)/29i 525(480)/29i, 625(576)/25i
Minimum Delay	1 line
Video Delay	1 line to 11 frames + 1line (synchronizing) 1 line to 11 frames – 1 pixel (delay mode)
Synchronizer Hysteresis Window	HD - 4 $\mu$ s SD - 11 $\mu$ s
Reference Source	External – HD tri-level (HD output only), SD bi-level, Input Video syncs
Genlock Adjustment	Up to $\pm$ 1 frame in steps of 1 pixel
Embedded Audio Handling	HD - 24-bit synchronous 48 kHz to SMPTE 299M SD - 20-bit synchronous 48 kHz to SMPTE 272MA
Embedded Audio Delay	Minimum 3 ms (PCM), 0.75 ms (Data), Maximum 2.5 s
Channel Status Information	Handled and checked
<b>Power Consumption</b>	
Module Power Consumption	10 W (max.) 10.5 W (max.) - Relay Bypass Version

## 3. Connections

This section describes the physical input and output connections provided by the IQSYN22.

### 3.1 IQSYN2226-1A / IQSYN2227-2A / IQSYN2239-2A

#### 3.1.1 SDI Inputs

Serial digital inputs to the unit are made to the unit via two BNC connectors which terminate in 75 Ohms.

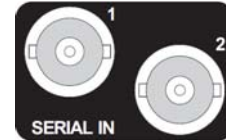

#### 3.1.2 SDI Outputs

Serial digital outputs from the unit are made to the unit via BNC connectors which terminate in 75 Ohms.

- 3 outputs (IQSYN2226-1A)
- 4 outputs (IQSYN2227-2A / IQSYN2239-2A).

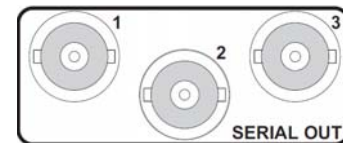

#### 3.1.3 Analog Reference Input

The external sync input to the unit is made via the passive loop-through BNC connectors for 75 Ohms.

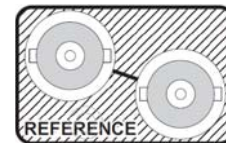

It should be noted that proper operation to the full specification can only be achieved with a correctly terminated, noise-free, stable, black sync reference input. Whilst lock may be achieved with an unsuitable sync source the increased jitter evident on the SDI output will affect locking and cable length performance at the receiving equipment.

**Note:** If the loop-through facility is not used, the unused BNC socket must be fitted with a 75 Ohm terminator.

#### 3.1.4 GPI

General Purpose Interface via BNC 75 Ohms connectors may be configured as inputs or outputs.

- 1 GPI (IQSYN2226-1A)
- 2 GPI (IQSYN2227-2A / IQSYN2239-2A).



## 4. Card Edge LEDs

The LEDs on the edge of the module indicate its operating status:

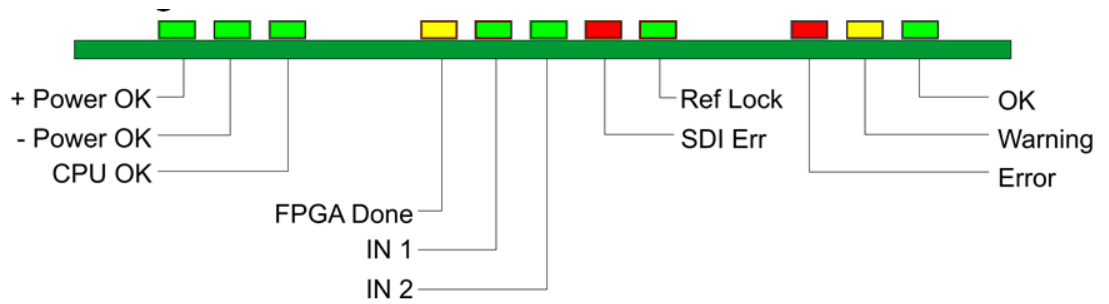

LED	Color	Description
<b>POWER +</b>	Green	Indicates that a positive power supply is present.
<b>POWER -</b>	Green	Indicates that a negative power supply is present.
<b>CPU OK</b>	Green	Flashes to indicate that the CPU is running.
<b>FPGA OK</b>	Yellow	Flashes when the FPGA is running. When the unit is booting, this LED is illuminated continuously, until the SDI is enabled.
<b>IN 1, IN 2</b>	Green	These LEDs are illuminated when a valid input is present at the Serial Data Inputs.
<b>SDI ERR</b>	Red	This LED is illuminated if any CRC, EDH or TRS errors are detected on the selected SDI input or a loss of SDI.
<b>REF LOCK</b>	Green	This LED indicates that a reference signal is present.
<b>ERROR</b>	Red	This LED indicates board fault conditions. When the unit is booting, this LED is illuminated, until the SDI is enabled. Board fault errors include: <ul style="list-style-type: none"> <li>• <b>Audio clock lock fault.</b> Audio sub-system fails to lock to video clocks.</li> <li>• <b>Serializer lock fault.</b> Output serializer fails to lock.</li> <li>• <b>SDI JTAG board fault.</b> Internal JTAG interface is inadvertently enabled.</li> </ul> Continuous illumination indicates a board fault and a service is required. Perform a Factory Reset and supply a valid SDI video source before calling service.
<b>WARNING</b>	Yellow	This LED indicates operational errors. Operational errors include: <ul style="list-style-type: none"> <li>• <b>Embedder Status - ANC overflow.</b> Indicates the embedder has run out of ancillary space over quite a few lines. Due to heavy use of ancillary space on the video input, particularly in SD.</li> <li>• <b>Input Video: Incompatible input standard.</b> Detected input standard is invalid.</li> <li>• <b>Input Video: SDI problem.</b> CRC or other SDI errors detected on selected input in the last whole field.</li> <li>• <b>Reference: Lock Failure.</b> Genlock failed to lock to selected source.</li> </ul> This LED may be briefly illuminated in transitional states like standard changes. Continuous illumination indicates a problem. More information is available in the status window.
<b>OK</b>	Green	Indicates that the module is operating correctly.

## 5. Controlling the IQSYN22 from the RollCall Control Panel

### 5.1 The Information Window

The information window is displayed in the upper-right corner of each screen and displays basic information about the input status, video, audio and reference status of the module.

Select either **Video Status**, **Audio Status** or **Metadata Status** to display the corresponding information.

#### 5.1.1 Video Status

When **Video Status** is selected, the status of the video input and reference is displayed:

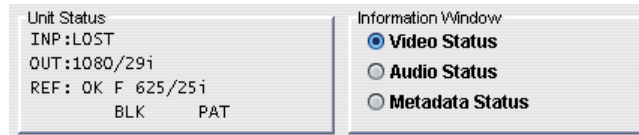

Name	Status	Description
<b>INP:</b> (Line 1)		Displays the status of the video input, followed by the standard of the input, or last valid signal.
	<b>OK 1080/29i</b>	Valid input signal received. Detected standard of input signal, or last valid input signal, is displayed, e.g. 1080/29i.
	<b>LOST</b>	No input signal received.
	<b>FAIL</b>	Invalid input signal received, e.g. frame rate differs between input and output.
	<b>MISM</b>	Valid input signal received but different (mismatched) format to the selected output, e.g. input is 1080/29i and output is 1080/29p.
<b>OUT:</b> (Line 2)		Displays the operating standard of the unit.
	<b>Unknown</b>	The input signal standard is not recognized.
	<b>1080/29i</b>	Operating standard is displayed, e.g. 1080/29i.
<b>REF:</b> (Line 3)		Displays the status of genlock, followed by the standard of the analog reference signal when in Free-Run or Lock to Reference mode.
	<b>FREE</b>	Free run, with no reference connected.
	<b>OK F 1080/29i</b>	Free run. Detected standard of reference signal is displayed, e.g. 1080/29i.
	<b>LOCK 1080/29i</b>	Valid reference and genlocked. Detected standard of reference signal is displayed, e.g. 1080/29i.
	<b>LK F</b>	Valid reference but ambiguous field type.
	<b>LOST</b>	No reference signal found.
	<b>FAIL</b>	Genlock not possible.
	<b>FAIL INP</b>	Failed to genlock to input.
	<b>LOCK INP</b>	Genlocked to input video.
	<b>(Line 4)</b>	
<b>ANC</b>		Ancillary present.
<b>FRZ</b>		Output frozen.
<b>PAT</b>		Output pattern.
<b>MON</b>		Monochrome.
<b>HBL</b>		Horizontal ancillary data is being blanked.
<b>BLK</b>		Output black.



### 5.1.2 Audio Status

When **Audio Status** is selected, the status of the embedded audio input is displayed where:

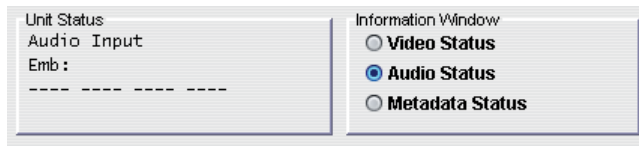

Name	Status	Description
Audio Input	P	Channel is a PCM audio input.
Emb:	<input type="checkbox"/>	No audio input is detected.
-----	D	Signal is data (non-PCM, Dolby, etc.).
	CLIP	Displayed if any audio level reaches the 0 dBFS point, i.e. the digital limit. The fader level should be reduced to prevent this occurring.
	ANC FULL	Indicates the embedder / ancillary formatter has run out of ancillary space over quite a few lines and has lost data. Caused by heavy use of ancillary space on the video input, particularly in SD.

### 5.1.3 Metadata Status

When **Metadata Status** is selected, the status of the embedded audio input is displayed where:

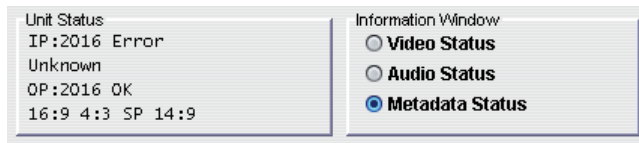

Name	Status	Description
(Line 1)	Displays the metadata input type.	Disabled Error OK
(Line 2)	Displays the currently detected input aspect ratio and AFD code.	Unknown   [ 4:3   16:9 ] [ Reserved(0)   Reserved(1)   Box 16:9 top   Box 14:9 top   Box>16:9 ctr   Reserved(5)   Reserved(6)   Reserved(7)   Coded Frame   4:3 center   16:9 center  14:9 center   Reserved(12)   4:3 SP 14:9   16:9 SP 14:9   16:9 SP 4:3 ]
(Line 3)	Displays the metadata output type.	OK
(Line 4)	Displays the current output AFD code.	Delete   [ 4:3   16:9 ] [ Reserved(0)   Reserved(1)   Box 16:9 top   Box 14:9 top   Box>16:9 ctr   Reserved(5)   Reserved(6)   Reserved(7)   Coded Frame   4:3 center   16:9 center  14:9 center   Reserved(12)   4:3 SP 14:9   16:9 SP 14:9   16:9 SP 4:3 ]

## 5.2 Video Input

The **Video Input** screen enables you to specify the settings for the video inputs:

- Selection of input source.
- Enable any specified backup rules.
- Specify the input loss conditions.
- Specify valid input standards.
- View information about CRC/EDH errors.

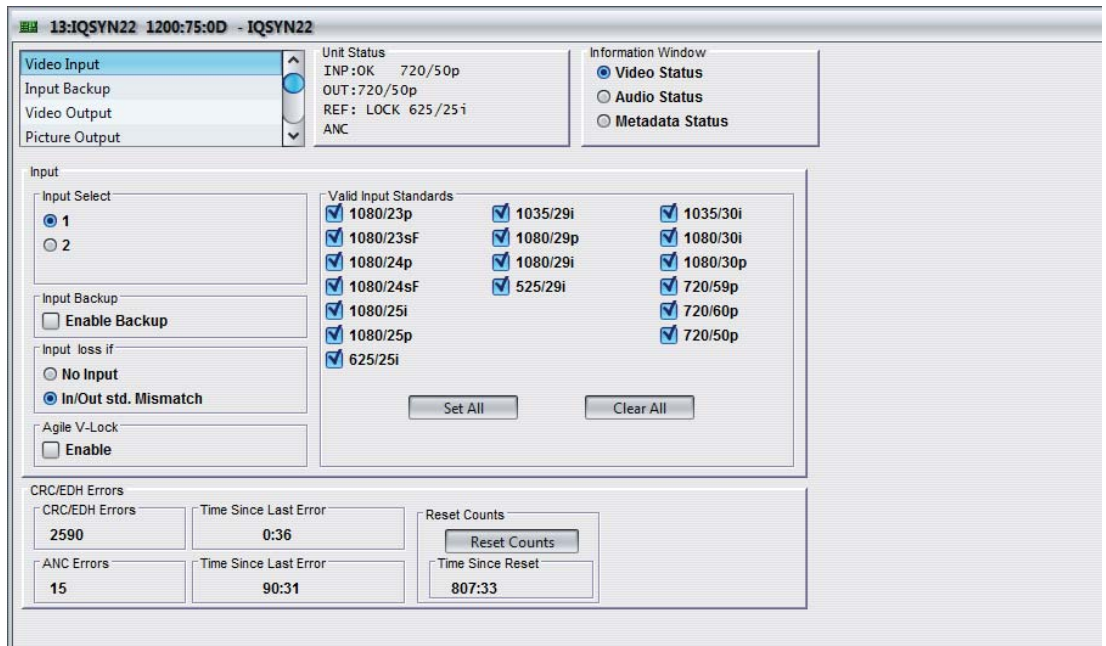

### 5.2.1 Input Select

Enables the selection of either input 1 or Input 2 for processing. This control is duplicated on the **Input Backup** screen.

### 5.2.2 Input Backup

When selected, if a backup rule is triggered, the action defined in the backup rules takes place. This control is duplicated on the **Input Backup** screen.

### 5.2.3 Input Loss If

The module can take automatic action if the input signal is lost. This control defines what is a loss of input and what will cause the automatic actions to be triggered.

- **No Input:** If there is no input signal of any type this will be considered to be a loss of input.
- **In/Out std. Mismatch:** If the standard of the input signal does not match the output standard this will be considered to be a loss of input.

### 5.2.4 Agile V-Lock

This function is intended to permit correct reception of upstream switched misaligned 625/25i and 525/29i sources without picture disturbance. In HD standards, a mechanism is in place to re-synchronize after a switch, which makes this mode unnecessary. A tolerance of +/- 5 lines misalignment between sources is permissible which is wider than the 5  $\mu$ s allowance specified in SMPTE RP-168, and it is assumed that the correct switch point with respect to the source is used.

**Note:** Due to the time required to recognize a change in picture framing in standard definition (SD) there must be a minimum delay of 4 lines so that no displaced picture is seen at the output during a misaligned switch. This may be assured in a synchronizing mode (external reference or free-run) by setting the Frames delay value to at least 1.

Application areas that require agility over delay will suit this function better. Poor and unstable signals may benefit from having this function disabled.

**Note:** Correct operation of agile V-lock requires a correct vertical reference point. On some legacy equipment from before 1995 the end of vertical blanking was on the permissible lines 10-19 as well as on the current line 20. This practice is no longer permitted, and will prevent correct vertical alignment of non-compliant legacy 525/59i sources. If this is the case then disable Agile V-Lock.

### 5.2.5 Valid Input Standards

The **Valid Input Standards** check boxes specify the video input standards that the module will accept. The module will automatically detect the standard of the received input and block any signal that does not comply with these selected video formats.

By default, all input standards are selected.

- **Set All:** Click this button to select all check boxes.
- **Clear All:** Click this button to de-select all check boxes.

**Note:** If any other standards are detected, an invalid standard will be assumed and this will force an input video loss with the FAIL status.

### 5.2.6 CRC/EDH Errors

This item provides information about the Cyclic Redundancy Checksum errors (CRC) and Error Detection Handling (EDH).

- **CRC/EDH Errors:** This displays the total CRC or EDH Full Frame error count since the last reset.
- **Time Since Last (CRC/EDH) Error:** This will show the time in 5 second intervals up to 1 minute then in minute intervals, since the last error was detected.
- **ANC Errors:** This will display the total number of ancillary data (ANC) errors since the last reset. All ancillary packets are checked. Hence, a problem video source or dropout can produce a large number of errors.
- **Time Since Last (ANC) Error:** This will show the time in 5 second intervals up to 1 minute then in minute intervals, since the last ancillary data error was detected.
- **Reset Counts:** This will reset the error counters to zero.
- **Time Since Reset:** This will show the time in 5 second intervals up to 1 minute then in minute intervals, since the counters were last reset.

**Note:** If the selected input changes, the CRC/EDH counts will be automatically reset once the software has decided that the input is correctly locked.

### 5.3 Input Backup

The **Input Backup** screen enables the IQSYN22 to be configured to detect if the input signal on Master (Inp 1) fails and automatically switch to the Backup (Inp 2) signal.

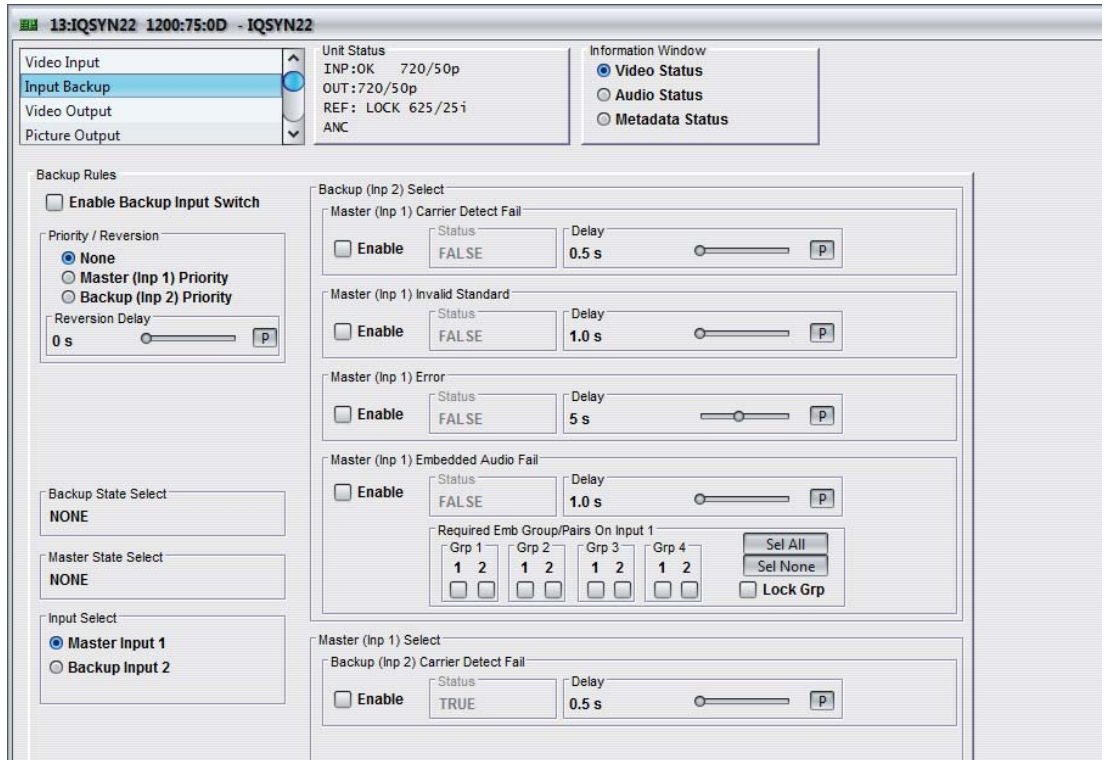

#### 5.3.1 Enable Backup Input Switch

Select this option to enable the input backup switch functions. This control is duplicated on the **Video Input** screen.

#### 5.3.2 Priority / Reversion

These settings apply to the Carrier Detect Fail controls and specify the input that will be given priority and the time that a lost signal must have been regained before the system will revert to the input that has priority.

- **None:** Neither Input 1 nor Input 2 has priority. If a signal is lost, causing the module to switch to the other input, when the signal is regained, the module will not revert to the original input.
- **Master (Inp 1) Priority:** Input 1 has priority. Normally, the module will use the Input 1 signal. If the signal on Input 1 is lost, the module will switch to Input 2. If the signal on Input 1 is subsequently recovered, the module will revert to using Input 1 after the time specified as the Reversion Delay has elapsed.
- **Backup (Inp 2) Priority:** Input 2 has priority. Normally, the module will use the Input 2 signal. If the signal on Input 2 is lost, the module will switch to Input 1. If the signal on Input 2 is subsequently recovered, the module will revert to using Input 2 after the time specified as the Reversion Delay has elapsed.
- **Reversion Delay:** Use the slider bar to specify the time that must elapse before the priority input will revert to a recovered signal. The range of adjustment is 0 - 100 seconds and the preset value is 0s.

**Note:** If the signal fails on both Input 1 and Input 2, the unit will switch to the priority input.

If any of the Backup (Inp 2) Select controls are enabled, the Priority/Reversion controls will not be available.

### 5.3.3 Backup State Select

This reflects the overall status of the Backup (Inp 2) Select controls, which are:

- Master (Inp 1) Carrier Detect Fail
- Master (Inp 1) Invalid Standard
- Master (Inp 1) Error
- Master (Inp 1) Embedded Audio Fail

If none of these options are enabled, Backup State Select will display None.

If all of the enabled options have a status of False, Backup State Select will display False.

If one or more (but not necessarily all) of the enabled options have a status of True, Backup State Select will display True.

### 5.3.4 Master State Select

This reflects the status of the Backup (Inp 2) Carrier Detect Fail control.

If the Backup (Inp 2) Carrier Detect Fail control is not enabled, Master State Select will display None.

If the Backup (Inp 2) Carrier Detect Fail control is enabled, Master State Select will display the control's status - either True or False.

### 5.3.5 Input Select

Use the radio buttons to manually select either Input 1 or Input 2. This control is also present on the Video Input screen. Changes made to the control on either screen will be reflected on the other.

### 5.3.6 Master (Inp 1) Carrier Detect Fail

When this option is enabled, Backup (Inp 2) will be selected if the signal on Master (Inp 1) is lost and is missing for more than the time specified by the Delay control.

- **Enable:** Select the check box to enable this option.
- **Status:** This displays the carrier status. It will show True in the event of failure, otherwise it will show False.
- **Delay:** Use the slider bar to specify the amount of time that must elapse before a change of status is reported. The range of adjustment is from 0.5 s to 10.0 s. The preset value is 0.5 s.

### 5.3.7 Master (Inp 1) Invalid Standard

When this option is enabled, Backup (Inp 2) will be selected if an invalid standard, as specified on the Video Input screen, is detected on Master (Inp 1) and remains for the time specified by the Delay control.

- **Enable:** Select the check box to enable this option.
- **Status:** This displays the Invalid Standard status. It will show True if an invalid standard is detected, otherwise it will show False.
- **Delay:** Use the slider bar to specify the amount of time that must elapse before a change of status is reported. The range of adjustment is from 1 s to 5 s. The preset value is 1 s.

### 5.3.8 Master (Inp 1) Error

When this option is enabled, Backup (Inp 2) will be selected if the signal on Master (Inp 1) is in error and in error for more than the time specified by the Delay control.

- **Enable:** Select the check box to enable this option.
- **Status:** This displays the input error status. It will show True if an error is present, otherwise it will show False.
- **Delay:** Use the slider bar to specify the amount of time that must elapse before a change of status is reported. The range of adjustment is from 1 s to 5 s. The preset value is 1 s.

### 5.3.9 Master (Inp 1) Embedded Audio Fail

When this option is enabled, Backup (Inp 2) will be selected if any of the audio groups specified by the Required Emb Groups/Pairs On Input 1 control fail for more than the time specified by the Delay control.

- **Enable:** Select the check box to enable this option.
- **Status:** This displays the audio status for audio that has been specified as required. It will show True for audio fail, otherwise it will show False.
- **Delay:** Use the slider bar to specify the amount of time that must elapse before a change of status is reported. The range of adjustment is from 1 s to 10 s. The preset value is 1 s.
- **Required Emb Groups/Pairs On Input 1:** Select the check boxes for all audio groups/pairs that are required in order for the input to be considered acceptable. If any selected audio group/pair fails for more than the time specified by the Delay control, the input will switch to Backup (Inp 2). If audio fails on a group/pair that is not marked as required, the input will be considered acceptable and no switch will occur.
  - **Sel All:** Selects all of the Required Emb Groups/Pairs On Input 1 check boxes.
  - **Sel None:** Clears all of the Required Emb Groups/Pairs On Input 1 check boxes.
  - **Lock Grp:** Selecting this option locks groups together. Selecting one channel in the group will automatically select the other. Clearing one channel in the group will automatically clear the other.

### 5.3.10 Backup (Inp 2) Carrier Detect Fail

When this option is enabled, Master (Inp 1) will be selected if the signal on Backup (Inp 2) is lost and is missing for more than the time specified by the Delay control.

- **Enable:** Select the check box to enable this option.
- **Status:** This displays the carrier status. It will show True in the event of failure, otherwise it will show False.
- **Delay:** Use the slider bar to specify the amount of time that must elapse before a change of status is reported. The range of adjustment is from 0.5 s to 10.0 s. The preset value is 0.5 s.



## 5.4 Video Output

Use the settings on the **Video Output** screen to:

- Specify the video output standard.
- Set up the test pattern, if any, to be generated.
- Specify the default output to be generated in response to a loss of input.
- Adjust the signal gain and black levels.
- Control the unit's monochrome functions.
- Control the unit's picture freeze function.

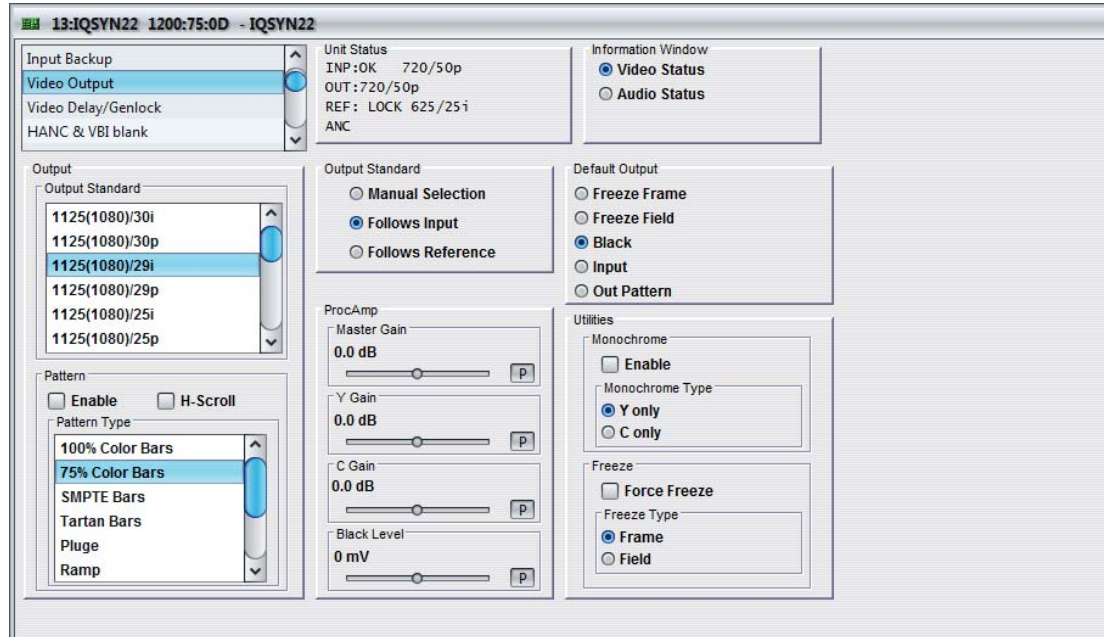

### 5.4.1 Output

Selects the output video standard, depending on whether Manual Selection, Follows Input or Follows Reference is selected. See "Output Standard" on page 23.

Select the output standard from the following list:

- |                 |                 |
|-----------------|-----------------|
| 1125(1080)/30i  | 1125(1080)/23sf |
| 1125(1080)/30p  | 1125(1035)/30i  |
| 1125(1080)/29i  | 1125(1035)/29i  |
| 1125(1080)/29p  | 750(720)/60p    |
| 1125(1080)/25i  | 750(720)/59p    |
| 1125(1080)/25p  | 750(720)/50p    |
| 1125(1080)/24p  | 525(480)/29i    |
| 1125(1080)/24sf | 625(576)/25i    |
| 1125(1080)/23p  |                 |



### 5.4.2 Output Standard

This function defines how the output standard is selected.

- **Manual Selection:** When selected, the output standard is the one selected via the Output/Output Standard list.
- **Follows Input:** When selected, the output standard is set to be the same as the input standard.
- **Follows Reference:** When selected, the output standard is set to be the same as the reference input standard.

**Note:** If you have selected Follows Input or Follows Reference, you can pre-select the output standard for use with the Manual Selection option. If you then select Manual Selection, the specified standard is used.

### 5.4.3 Pattern

This enables the pattern functions to be set up.

- **Enable:** When checked, the output will become the pattern selected from the Pattern Type list.
- **H-Scroll:** When checked, the selected pattern will scroll from left to right at a fixed rate. This mode is useful for differentiating between an input test pattern signal that has become a frozen picture (caused by a loss of input signal) and a test pattern that has been chosen to be the output.

#### 5.4.3.1 Pattern Type

This enables a pattern to be selected from the list. This pattern will become the output signal when Pattern/Enable is checked. Options are as follows:

100% Color Bars	Ramp
75% Color Bars	Sweep
SMPTE Bars	Pulse & Bar
Tartan Bars	Burst
Pluge	Black

### 5.4.4 Default Output

This controls the module’s response to a loss of input signal as set via the Video Input/Input Loss if and Valid Input Standards functions. Options are:

- **Freeze Frame:** When selected, the output becomes a frozen frame picture.
- **Freeze Field:** When selected, the output becomes a frozen field picture.
- **Black:** When selected, the output picture cuts to black.
- **Input:** When selected, the incoming signal is displayed whenever possible.
- **Out Pattern:** When selected, the output picture will become the pattern selected via the Output/Pattern Type function.

### 5.4.5 ProcAmp

This function allows the gain and black level of the signal to be adjusted.

- **Master Gain:** This enables the overall gain (Y and Cb/Cr) to be adjusted over a range of  $\pm 6$  dB in steps of 0.1 dB. Preset value is 0.0 dB.
- **Y Gain:** This enables the Y (luminance) gain to be adjusted by  $\pm 6$  dB in steps of 0.1 dB. Preset value is 0 dB.
- **C Gain:** This enables the Cb/Cr (color difference) gain to be adjusted by  $\pm 6$  dB in steps of 0.1 dB. Preset value is 0 dB.

**Note:** The total range of both Master + Y and Master + C controls is +6 dB to -10 dB.

- **Black Level:** This enables the black level to be adjusted by  $\pm 200$  mV in steps of 1 mV. Preset value is 0.
- **Hue:** This enables the hue to be adjusted from -45 degrees to +45 degrees. Preset is to 0 degrees.

### 5.4.6 User Caption

These controls enable a user-configurable caption to be displayed on the video output.

- **Enable:** When selected, this enables the video caption.
- **Text:** Enter the caption text in this field, and then click **S** to save. Click **P** to return to the default text (Captions ON). A maximum of 16 characters can be entered.
- **X Pos / Y Pos:** Use the slider bars to position the caption along the X and Y axis.
- **X Size / Y Size:** Use the slider bars to resize the height and width of the caption. The range of each is 1 to 5 units.

### 5.4.7 Utilities

#### 5.4.7.1 Monochrome

These controls enable the monochrome output functions to be configured.

- **Enable:** When selected, the monochrome functions are enabled.
- **Y Only:** When selected, the output picture becomes monochrome using only the Y component of the signal.
- **C Only:** When selected, the output picture becomes monochrome using only the CbCr components of the signal.

#### 5.4.7.2 Freeze

These controls enable the freeze output functions to be configured.

- **Force Freeze:** When selected, the output picture becomes frozen.
- **Frame:** When selected, the frozen output picture is derived from a Frame.
- **Field:** When selected, the frozen output picture is derived from a Field.

**Note:** The Freeze function is disabled on a power cycle of the module.

## 5.5 Picture Output

The **Picture Output** screen enables the adjustment of:

- Luma clipper
- RGB legalizer
- Advanced horizontal enhancement

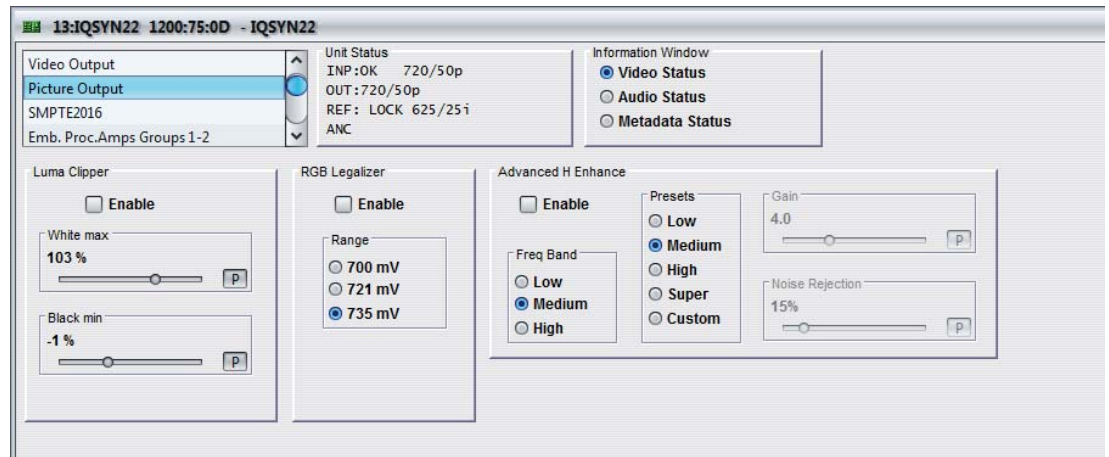

### 5.5.1 Luma Clipper

When luminance levels are too high or too low, devices such as encoders and displays can have problems. The luma clipper is used to limit signals above and below predefined limits.

- **Enable:** Select to enable the Luma Clipper
- **White Max:** This sets the upper limit of the clipper. The range is minimum 90% (825 digital 10-bit value) to maximum 109% (1019) with increments of 1%. The preset value is 103%.
- **Black Min:** This sets the lower limit of the clipper. The range is minimum -7% (4) to maximum 10% (152) with increments of 1%. The preset value is -1% (55).

### 5.5.2 RGB Legalizer

RGB gamut legalization ensures that both the HD and SD outputs of the unit meet specified color limits.

- **Enable:** Select to enable the RGB Legalizer
- **Range:** The 735 mV selection should be used in conjunction with the luma clipper (set at presets) to generate images that adhere to EBU R103-200 specification.
  - 700 mV - RGB Lo 0 mV, RGB Hi 700 mV.
  - 721 mV - RGB Lo -21 mV, RGB Hi 721 mV.
  - 735 mV - RGB Lo -35 mV, RGB Hi 735 mV.

### 5.5.3 Advanced H Enhance

The Advanced Horizontal Enhancer allows enhancement to be selectively applied to the low-frequency band, medium-frequency band, or high-frequency band. Four presets are available as well as custom gain and noise rejection.

- **Enable:** Select to enable advanced horizontal enhancement.
- **Freq Band:** Select the frequency band to which enhancement will be applied.

- **Presets:**
  - **Low:** Sets Gain to 2.0 and Noise Rejection to 15% for the selected frequency band.
  - **Medium:** Sets Gain to 4.0 and Noise Rejection to 15% for the selected frequency band.
  - **High:** Sets Gain to 6.0 and Noise Rejection to 15% for the selected frequency band.
  - **Super:** Sets Gain to 8.0 and Noise Rejection to 15% for the selected frequency band.
  - **Custom:** Enables Gain and Noise reduction to be manually adjusted.
- **Gain:** If the Custom preset is selected, this allows the Gain to be adjusted on the selected frequency band.
- **Noise Rejection:** If the Custom preset is selected, this allows the Noise Rejection to be adjusted on the selected frequency band.

## 5.6 SMPTE2016

The **SMPTE2016** screen provides controls to pre-configure an AFD / aspect ratio input mapping to any AFD / aspect ratio combination. This mapping is frame accurate as long as input line number is before or the same as the output line number.

**Note:** Ensure that VANC and Blanking is set up correctly for use with this feature.

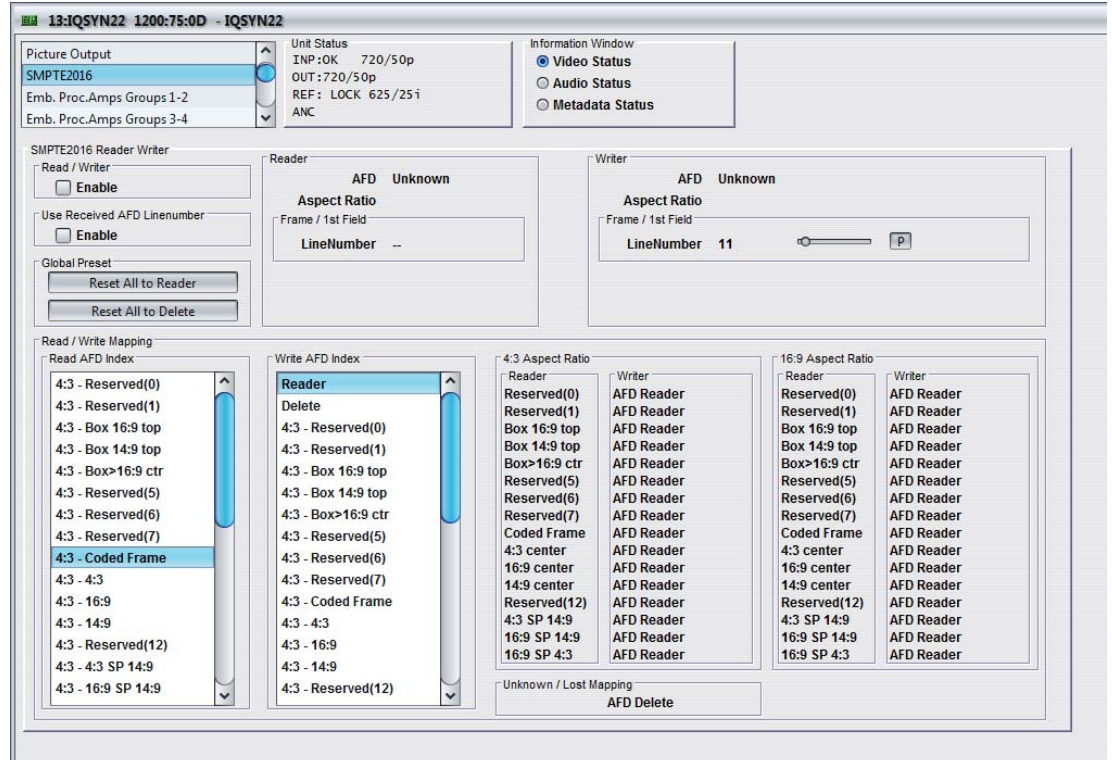

### 5.6.1 Read / Writer

Select the **Enable** checkbox to enable the functions and controls provided in the Reader and Writer areas of this screen. Clear the checkbox to disable these functions. When disabled, ancillary data operates in pass-through mode.

### 5.6.2 Use Received AFD Line Number

When this option is selected the SMPTE2016 information will be written in the output on the same line on which it is read in the output.

### 5.6.3 Global Preset

- **Reset All to Reader:** Click this button to set all Write AFD Index settings to Reader.
- **Reset All to Delete:** Click this button to set all AFD Write Index settings to Delete.

### 5.6.4 Reader

This section displays the aspect ratio and AFD that is currently being detected and the lines on which the 1st and 2nd fields occur. Note that the 2nd field is not displayed in progressive video output formats.

### 5.6.5 Writer

This section displays the output mapped aspect ratio and AFD, and enables the output line number on which SMPTE2016 information is written to be specified.

- **Frame / 1st Field:** Use the slider bar to specify the output line in the first field. The range of values varies depending on the standard and the preset value is two lines above the minimum value for the standard. If any other ancillary data is detected on the selected line In Use is displayed to the right of the control. If no other ancillary data is detected on the selected line (i.e. the line is available to carry SMPTE2016 data) Line OK is displayed to the right of the control.
- **2nd Field:** Use the slider bar to specify the output line in the second field. The range of values varies depending on the standard and the preset value is two lines above the minimum value for the standard. If any other ancillary data is detected on the selected line In Use is displayed to the right of the control. If no other ancillary data is detected on the selected line (i.e. the line is available to carry SMPTE2016 data) Line OK is displayed to the right of the control. This control is not displayed with progressive output video formats.

**Note:**

The line number controls are not available if Use Received AFD Linenumber is enabled.

The Line OK / In Use indicator does not detect all ancillary data; for example, WSS is not detected.

Inserting AFD will overwrite existing data present on the input line.

### 5.6.6 Read / Write Mapping

These controls enable the SMPTE2016 mappings to be specified. To do this, first, select the Read AFD Index and then select the Write AFD Index to be output when the selected AFD code is present on the input.

When Reader is selected as the Write AFD Index, the AFD code detected on the input will be passed to the output unchanged. When Delete is selected as the Write AFD Index, the AFD code will not be passed to the output.

These mappings are displayed in the 4:3 Aspect Ratio and 16:9 Aspect Ratio boxes to the right of the control. Unknown / Lost Mapping displays the action that has been specified when the incoming AFD code is not recognized or input is lost.

## 5.7 Embedded Proc Amp Groups 1-2 and 3-4

The **Embedded Proc Amp Groups 1-2 and 3-4** screens enable the gain of the 16 embedded audio channels to be adjusted. They also enable phase inversion and instant mute to be applied to any channel.

**Note:** These controls will not be available when the embedder is disabled or if an output is defined as being data or mixed or the input used is data.

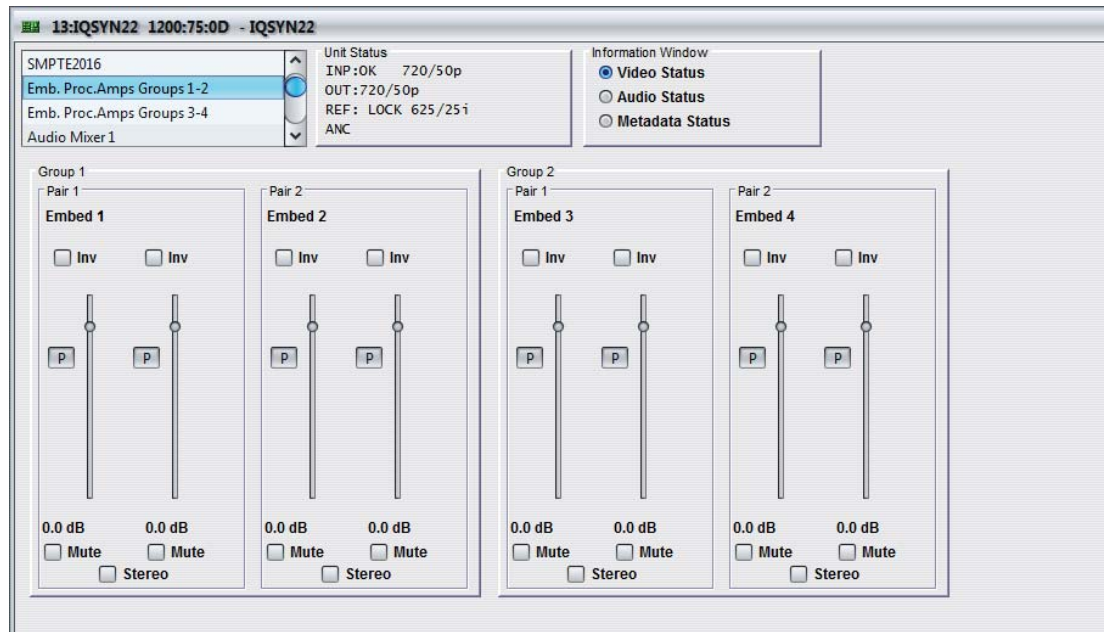

### 5.7.1 Groups 1 to 4, Pairs 1 and 2 (Embed 1-8 L & R)

This allows the channels to be controlled.

- **Inv(ert):** When checked, the signal polarity will be inverted.
- **Gain Controls:** The sliders allow the gain of the channel to be adjusted over a range of +12 to -66 dB in 0.1dB steps. The preset (**P**) is to 0 dB.

**Note:** Gains of greater than 0 dB can cause the signal to exceed the 0 dBFS digital limit, dependant on the material. This will produce serious distortion (clipping), which should always be avoided.

- **Clip Indicators:** At the top of each slider the word 'Clip' will appear briefly if the audio level reaches the 0 dBFS point, i.e. the digital limit. The slider level should be reduced to prevent this occurring.
- **Mute:** When checked, the channel will be muted.
- **Stereo:** When checked, the two channels of the pair will be linked together (configured as a stereo pair) and any adjustments made to one channel will automatically be applied to both channels. This allows rapid harmonious adjustment when audio pairs are carrying stereo signals.



## 5.8 Audio Mixer

The **Audio Mixer** screen enables new, mixed audio feeds to be created from the incoming audio channels. This is useful when, for example, stereo incoming feeds are required in mono or discrete surround-sound feeds are required in stereo.

Not only can the incoming feeds be mixed together but the exact balance can be set using the sliders. This allows finer control over the resulting sound than a simple mono function. Additional applications include mixing together incoming background audio with local foreground audio such as adding commentary to a sports feed. The invert function can be applied to one of the channels being mixed to create a mix-minus channel for foldback.

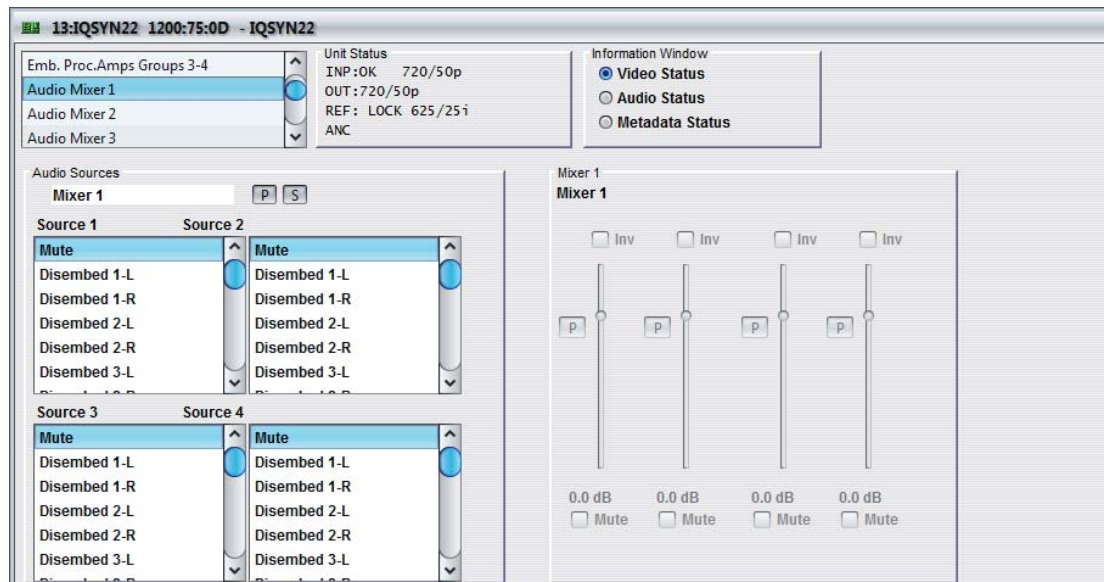

### 5.8.1 Audio Sources

The inputs can be selected from the list in the **Source 1, 2, 3** and **4** listboxes.

The outputs of these mixers provide four extra input selections for the Channel Router.

**Note:** If Mute or one of the test tones is selected as the source (i.e. a fixed level signal source), the corresponding gain control will be grayed out and will not be adjustable.

To change the name of a mixer, type the new text in the text area and then select Save (**S**). The new name will replace the name in the mixer gain control section. Selecting Preset (**P**) returns the text to the default text (Mixer 1, Mixer 2, Mixer 3 or Mixer 4).

### 5.8.2 Mixer

Each of the four mixers has four inputs with individual gain controls that allow the mixing levels for each of the input signals, to be adjusted.

- **Inv(ert):** When checked, the signal polarity will be inverted.
- **Gain Controls:** The sliders allow the gain of the channel to be adjusted over a range of +12 to -36 dB in 0.1dB steps. The preset (**P**) is to 0 dB.

**Note:** Gains of greater than 0 dB can cause the signal to exceed the 0 dBFS digital limit, dependant on the material. This will produce serious distortion (clipping), which should always be avoided.

- **Clip Indicators:** At the top of each slider the word 'Clip' will appear briefly if the audio level reaches the 0 dBFS point, i.e. the digital limit. The slider level should be reduced to prevent this occurring.
- **Mute:** When checked, the channel will be muted.

### 5.9 Embedded Routing Groups 1-2 and 3-4

The **Embedded Routing Groups 1-2 and 3-4** screens enable the signal sources for the SDI embedder to be selected from a list. Mute and audio tones may also be selected. The channels can be selected individually for total control over the embedded audio.

By default, there is a 1:1 relationship between the input source and the output. For example, channel one input is matched with the channel one output, channel two input is matched with channel two output, and so on.

Limited Channel Status information will usually be reinserted for audio, tones and mute. This is with the exception of Mixed which mode passes the incoming channel status directly.

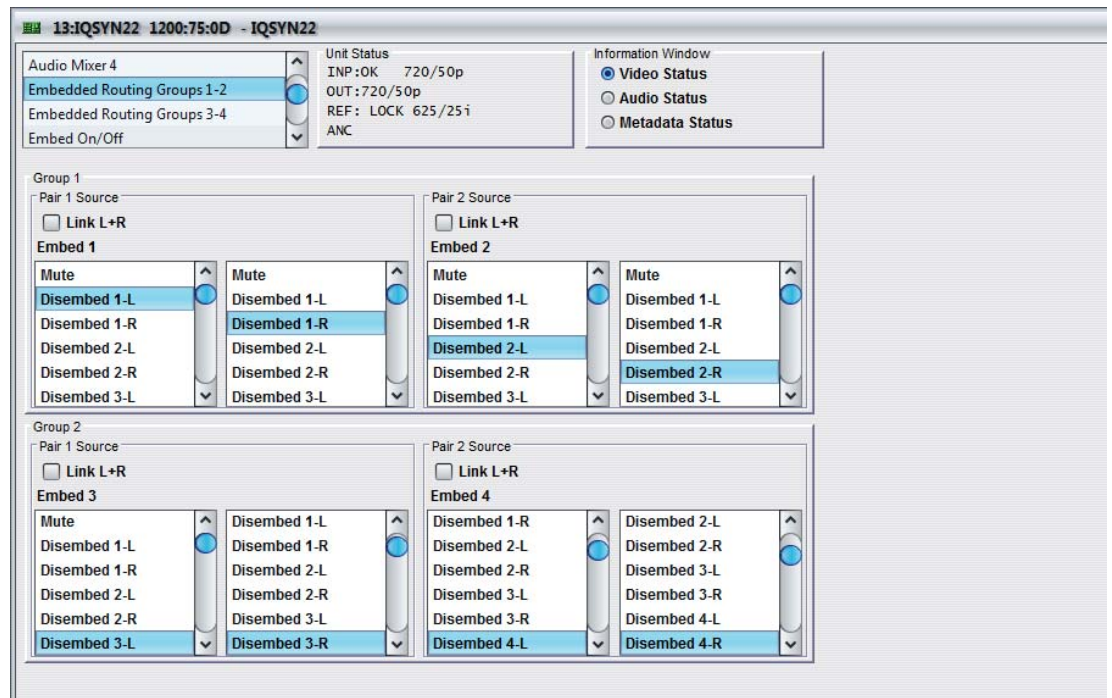

#### 5.9.1 Link L+R

When checked, the selected source will be automatically paired with the corresponding left/right source and configured as a stereo pair.

**Note:** A corresponding left/right source will be automatically chosen when available.

If a mixer output is selected as a source, a different mixer output will be automatically chosen for the other left/right channel. Mix 1 and 2, or mix 3 and 4 are paired.

If a tone is selected as the source the same tone will be automatically selected for the other left/right channel.

When an input pair is defined as data, an automatic pairing is established, similar to the Link L+R function. If either channel of a data pair is selected, the other half will automatically follow in the correct L+R order.

### 5.10 Embed On/Off

The **Embed On/Off** screen enables you to specify how the module handles the embedding of audio into the output HD-SDI or SD-SDI video stream. The audio inputs are arranged into four groups, comprising two channel pairs each.

For each group, you can configure the module to to:

- Pass audio unchanged.
- Remove audio data from the stream.
- Embed audio data into the stream.

By default, audio data is embedded in each group.

Within each group, you can also specify whether each channel, for example, Pair 1 Left or Pair 1 Right, is active or disabled. A disabled channel is muted and flagged as absent, with the channel status indicating 48 kHz synchronous audio. This does not change the group behavior.

For more information about Audio Embedding, see “Ancillary Passing” on page 69.

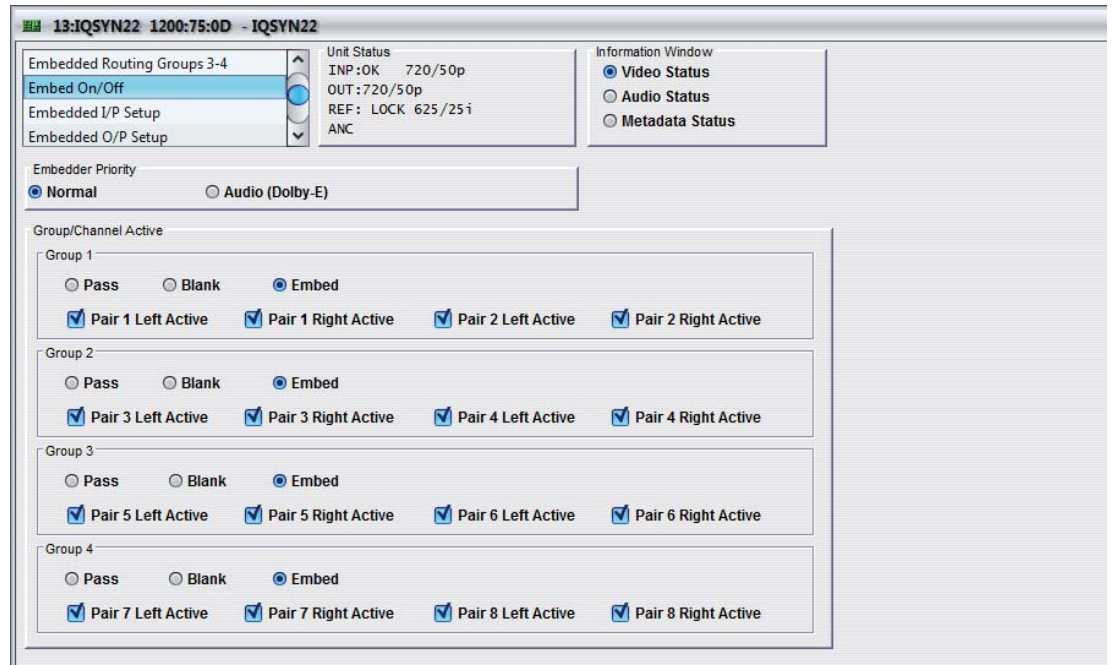

#### 5.10.1 Embedder Priority

Selecting Audio (Dolby E) causes audio to be embedded first. This ensures that audio data, such as Dolby E is on a specific line. If processing Dolby E, it is recommended that this option is selected.

#### 5.10.2 Group/Channel Active

For each Group (Group 1 to Group 4):

- To allow audio data to pass through the unit unchanged, select **Pass**.
- To remove audio data from the incoming stream, select **Blank**.
- To embed audio data into the stream, select **Embed**.

For each channel within each group:

- To activate the channel, select the corresponding check box.
- To disable the channel, clear the corresponding check box.

## 5.11 Embedded I/P Setup

The **Embedded I/P Setup** screen enables you to specify whether an input audio pair should be treated as:

- PCM audio
- Data
- Mixed mode

This screen also allows the names of the disembedded audio inputs to be changed from the default names (Disembed 1 etc.).

Embedded audio is a pair-based system. This means that they carry the sound as two channels and it is not possible to carry just one channel. Of course, the IQSYN22 can pass and process either channel as well as both. This is because the module is channel-based internally. When an embedded feed is used to carry non-PCM data then the whole data space is allocated to that function. In this mode the feed has to be treated together, it has to be treated as the equivalent of a pair. For example, a non PCM feed at the input will occupy the same space as two audio channels and must be passed to the output as two channels of data.

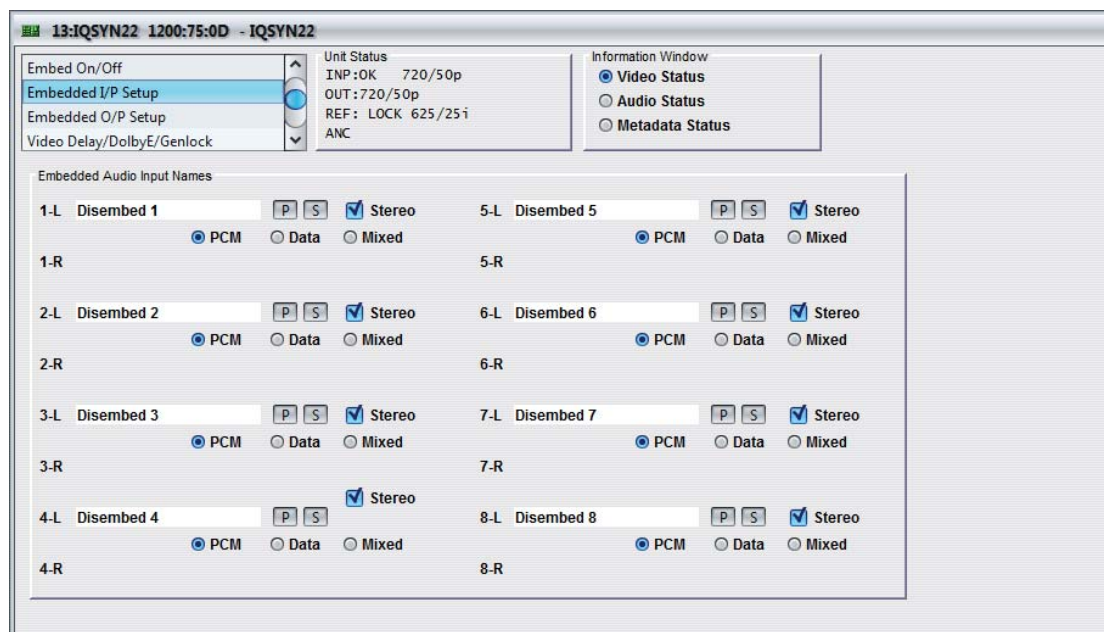

### 5.11.1 Embedded Audio Input Names

The name of each L and R channel (initially **Disembed 1-8**) may be directly over-written in the text box, as required. These names are used in the lists for the following functions:

- Audio Mixer Inputs
- Embedded Routing
- Embed Input Setup

Names are stored as part of the Memory function so that a new set of names can be recalled by a memory.

- **Stereo:** When selected, designates the corresponding L and R channels as a stereo pair, which may be allocated an input name. The Save (**S**) button saves changes made to the name. The Preset (**P**) button returns the name to the default of **Disembed 1-8**.

**Note:** When **Stereo** is selected for an audio pair, the corresponding right (R) member of the audio pair is not displayed on the screen. This is the default setting.

- **PCM:** The pair will be treated as PCM audio by the module. PCM processing can be either channel-based or stereo-based. By default, channels are configured as stereo pairs. To switch to channel-based processing, clear the Stereo check box. PCM mode allows audio-specific operations, such as gain and tracking delay, to be adjusted by means of the Mixers and Proc Amps. In PCM mode, channel status is overwritten with filtered channel status from the input, and is assumed to be steady state 48 kHz synchronous professional, with audio or data type as indicated on the source. If Data is flagged by channel status the unit will still respond by disabling processing operations including sample rate conversion, and forcing pair-based routing, thus giving a data-compatible audio path.
- **Data:** The pair will be treated as a non-PCM data feed through the circuitry within the module. This mode also protects the feed from PCM audio-specific operations such as gain and tracking delay. It also ensures that the audio is routed as a pair. In Data mode, channel status is overwritten with filtered channel status from the input, and is assumed to be steady state 48 kHz synchronous professional, with audio or data type as indicated on the source. One stream is equivalent to two PCM audio channels so in this mode there are no operations that can split the data. PCM audio will still be passed, and the channel status will follow the input type.
- **Mixed:** Processing occurs as with Data mode; however, the channel status overwrite mechanism is bypassed and set to 'pass through' on a channel by channel basis. One stream is equivalent to two PCM audio channels so in this mode there are no operations that can split the data. This mode is suitable for processing Dolby E and Dolby AC3 (Dolby Digital) data, when transitions between data and PCM audio will be passed cleanly with the source channel status, allowing decoders the best chance of handling the transition.

## 5.12 Embedded O/P Setup

The **Embedded O/P Setup** screen enables the names of the embedded audio outputs to be changed from the default names (Embed 1, etc.). By default audio outputs are designated as stereo pairs.

Names are stored as part of the Memory function so that a new set of names can be recalled by a memory.

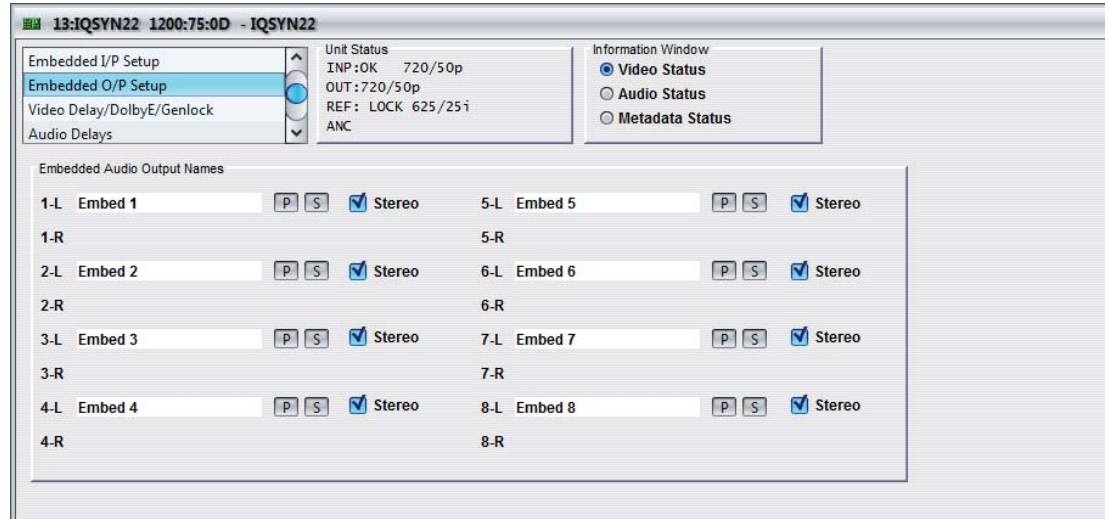

### 5.12.1 Embedded Audio Output Names

The name of each L and R channel (initially **Embed 1-8**) may be directly over-written in the text box, as required. Names entered here appear in the Embed Proc Amps and Embedded Routing screens.

- **Stereo:** When selected, designates the corresponding L and R channels as a stereo pair, which may be allocated an output name. The Save (**S**) button saves changes made to the name. The Preset (**P**) button returns the name to the default of **Embed 1-8**.

**Note:** When **Stereo** is selected for an audio pair, the corresponding right (R) member of the audio pair is not displayed on the screen. This is the default setting.



### 5.13 Video Delay/DolbyE/Genlock

The **Video Delay/DolbyE/Genlock** screen enables control of the video delay, Dolby E and Genlock functions.

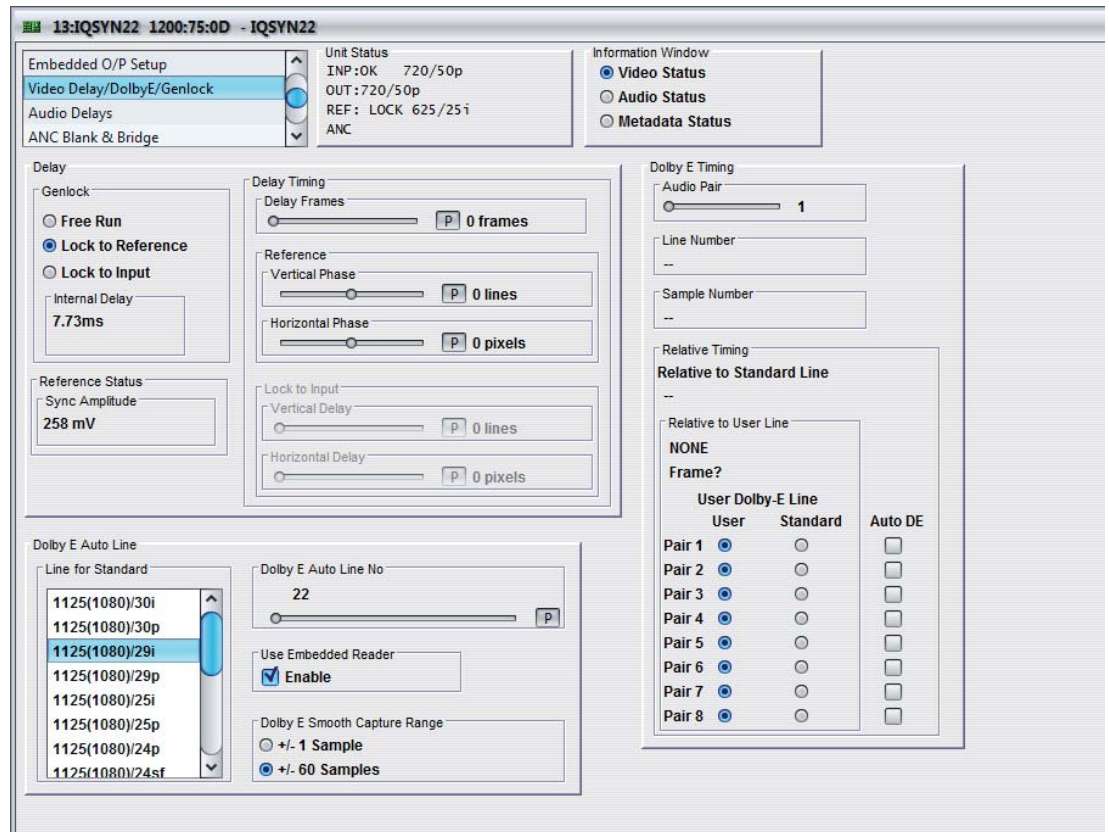

As a frame-based video synchronizer with up to 11 frames of storage, there are many possibilities for timing the output video. Each has an impact on delay through the unit and the possible level of control. Of these there are two classes of operation: referenced modes and delay modes.

#### Referenced Modes

In a referenced mode, video output is independently timed from the input, so that the output is always aligned to the reference raster to match other equipment for switching and processing purposes. This is the normal frame synchronizer operating mode, in which the buffer will always have a good whole frame of video to display (whether live, frozen, black or test pattern). In addition, due to the independence of output timing, it will be able to "firewall" the video. See page 67 for further details.

The delay through the unit remains within the one-frame operating range of the buffer but cannot be directly controlled since it is externally defined by the output and input references. However, phasing relative to any external output reference is adjustable.

#### Delay modes (Lock to Input)

Delay modes use the input reference to determine the output reference. These are not synchronizing modes but are utility delay generation modes, which may be useful when audio processing or a simple delay is required. The output is stable only if the input is stable, so it is not, therefore, a viable firewall mode.

The total delay is summed from calculated and measured delays to a resolution of one video line, and shown in the Internal Delay box. This is then available for use in the tracking Audio Delays.



### 5.13.1 Genlock

The Genlock function enables you to specify the Genlock or Video Delay mode, which defines the source of timing for the output video.

- **Free Run:** This is a special case of referenced type mode. When selected, the unit's output will not be locked to any input signal. Instead, it will run nominally at the correct frame rate and synchronize input video to this. No Horizontal or Vertical Timing adjustments are possible, but the delay can be stepped in frame increments up to 10 additional frames. This mode may be used to stabilize and firewall poor sources in the absence of a station reference.
- **Lock to Reference:** This is the normal referenced mode. When selected, the unit will lock to an external black (burst) reference signal, either bi-level SD or tri-level HD. Horizontal or Vertical Timing adjustments are possible for correctly phasing to match other sources, and the delay can be stepped in frame increments up to 10 additional frames. It's most likely use is to stabilize, firewall and correctly phase (synchronize) incoming line or post-router switched sources to a station reference.

This reference should be correctly terminated and clean of noise and jitter to give the best possible results. A bi-level reference of the correct frame rate is always acceptable, but a tri-level HD reference is only acceptable for a HD output. There are many cross-locking modes possible, and for this purpose the correct frame rate is either the output frame rate or double or half the rate - when an interlaced output is referenced to a progressive source the field relationship is unknown and this is indicated with REF: LK-F in the status window. When an unsuitable reference is given the unit will fail to lock and REF: FAIL will show in the video status window.

Since a stable output is required, considerable damping is applied to the locking characteristics. This results in an acquisition time of 5 to 10 seconds typically.

In this mode, Reference Status displays the amplitude of the reference sync signal, either peak for bi-level (typically 300 mV) or peak-peak for tri-level (typically 600 mV). Note that unterminated tri-level syncs will have the indication clipped to around 1 Volt.

**Note:**

Agile V-lock mode for SD requires at least 4 lines delay. Frames should be set to at least 1 for clean misaligned switches when synchronizing or phasing, to allow >4 lines minimum delay when re-timing stable but switched sources.

When synchronizing with Dolby E alignment, set Delay Frames to 1 or greater to allow optimum tracking of the Dolby E header position.

- **Lock to Input:** This allows the adjustment of the delay by changing the vertical and horizontal timing.

When a delay is required to be defined in terms of video lines, maybe to round up to the next frame boundary, this mode can be used. However, it may introduce complications on changes of video standard, and the minimum delay can go below the 0.75 ms audio minimum delay that would permit delay matching.

- **Internal Delay:** This displays the value of the current delay in milliseconds. This is useful to check that a suitable delay has been set.

**Note:**

When the delay is set below the minimum possible, this control will limit at 1 video line.

When the delay is set above the maximum possible, this control will limit at just below 1 video frame.

### 5.13.2 Delay Timing

The Delay Timing function is only available in **Lock to Reference** and **Lock to Input** modes. It enables you to specify the vertical and horizontal timing, which enables video delay to be adjusted in steps of one line.

- **Delay Frames:** This slider enables the video delay to be adjusted in steps of one frame. The range of adjustment is 0 to 11 frames. The preset value is 0 frames.
- **Vertical Timing:** This slider enables the video delay to be adjusted in steps of one line. The range of adjustment is one line short of an output frame in either direction. The preset value is 0 lines.
- **Horizontal Timing:** This slider enables the video delay to be adjusted in steps of one line. The range of adjustment is one pixel short of an output line in either direction. The preset value is 0 pixels.

The total delay is the sum of vertical and horizontal timing. An overall effect is to enable a delay of 1 frame - 5 lines, for example, to align an earlier 5-line delay device to the next frame boundary.

The sum of vertical and horizontal timing is post-limited to be under +/- a frame of the current standard. There is also a forced minimum delay of 1 line.

### 5.13.3 Dolby E Timing

An indication of Dolby E header phasing at the outputs helps in making corrections and avoids clicking or other corruption on downstream switching due to the 5% inter-frame guard band being misaligned with the video switch point.

Each of the eight output embedded pairs, including passed input audio groups, can be selected for display and logging. The display will report (for both the standard and the user-defined line) a line offset, or indicate a missing Dolby E header, for example, indicating PCM audio.

- **Audio Pair:** Selects one of the eight embedded audio pairs.
- **Line Number:** Reports the actual line number on which the Dolby E header occurs. Note that, depending on audio packet distribution, this may differ slightly from the expected line number. For example, if the expected line number is 22, line 21 or 23 may periodically be reported. This is a normal occurrence and does not necessarily indicate an error condition.
- **Sample Number:** Reports the current audio sample number.

Dolby E position is reported Early, Late, or OK within the limits for each output standard as shown below. 'Frame ?' is reported if the video frame rate is at twice the audio frame rate. In this situation, the audio aligns to the nearest video frame. Since the number of video frames will be double the number of audio frames, the audio delay may require adjustment in order to align with the correct video frame.

There are two levels of limits for status and logging. For safe and reliable operation, the OK limit is +/- 3 samples from the specified point, with WARN indications for up to the table limits, and ERROR indications beyond (this will definitely cause packet corruption on switching).

Standard	Switch Point	Early Line	Normal Line	Late Line
625/25i	6	<9	11	>30
525/29.97i	10	<12	14	>29
1080/25i 1080/25p	7	<16	20	>55
1080/29.97i	7	<17	22	>55
1080/29.97p				
1035/29.97i				
720/50p	7	<22	27	>73

Standard	Switch Point	Early Line	Normal Line	Late Line
720/59.94p	7	<23	29	>73

**Note:** All HD standards use line 7 for the frame switching line. Unsupported frame rates are: 23.98, 24, 30, 60 in i or p or sf standards.

### 5.13.3.1 User Dolby-E Line

If the Dolby E delay has been manually configured, select **User** next to corresponding audio pairs to specify which of the eight audio pairs will monitor the user line for status and logging. Alternatively, select **Standard** to monitor the standard Dolby E line.

### 5.13.4 Dolby E Auto Line

The Dolby E Auto Line settings specify a video line for Dolby E header alignment. For any pair with **Auto DE** enabled, the audio delay will attempt to align the output audio guard band on this video line, while keeping the delay within  $\pm 0.5$  frame of nominal. Each video standard may have its own line specified, so that a change of standard will automatically call up the appropriate line for alignment to.

#### 5.13.4.1 Line for Standard / Dolby E Auto Line No

This allows access for defining and viewing the table of user specified lines for Dolby E auto alignment, status reporting and logging. Defaults for each standard are the published 525/29i and 625/25i positions mapped onto the supported standards, i.e. assuming the encoders / decoders are referenced to SD.

From the Line for Standard list, select the input video standard, this will automatically adjust the Dolby E Auto Line No, which can also be manually adjusted by means of the slider bar. The default Dolby E line numbers for the supported video standards are shown in the following table.

Line for Standard	Dolby E Auto Line No
1125(1080)/29i	22
1125(1080)/29p	22
1125(1080)/25i	20
1125(1080)/25p	20
1125(1035)/29i	22
525(480)/29i	14
625(576)/25i	11

#### 5.13.4.2 Use Embedded Reader

This option allows the automatic Dolby E alignment adjustment to be made using the actual embedded data to improve the accuracy of the correction, and ensure the requested line is achieved. If Use Embedded Reader is not enabled, the correction is applied at the audio delay output, before the embedder and, as such, may not be as accurate.

#### 5.13.4.3 Dolby E Smooth Capture Range

This control provides a limit for deciding at what point a change in Dolby timing will cause a immediate jump to the new timing (either from a sync event or movement of Dolby in the guard band). If the move is less than the number of configured samples, the change will be smooth. If the move is greater than the number of configured samples, a “crash” change will result.

**Note:** When a “crash” change occurs, you may hear pops or clicks on the audio when it changes to the new value.

### 5.14 Audio Delays

The **Audio Delays** screen enables control of audio delay.

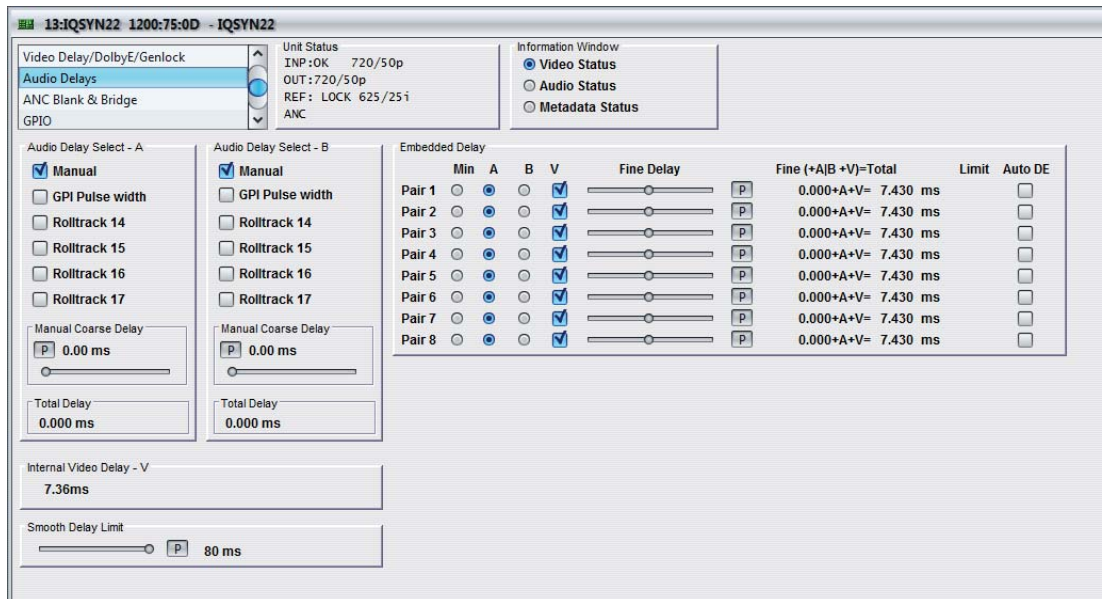

There are eight separate delay blocks provided by this module. Each delay block processes a pair of PCM audio channels or one non-PCM data feed. The delay blocks can be controlled by one of two composite control feeds that permit external adjustment, and an internal matching delay option. Each control feed can be driven by a combination of both tracking and fixed delays. Tracking delays are those that can follow a variable timing value such as the delay through a video synchronizer.

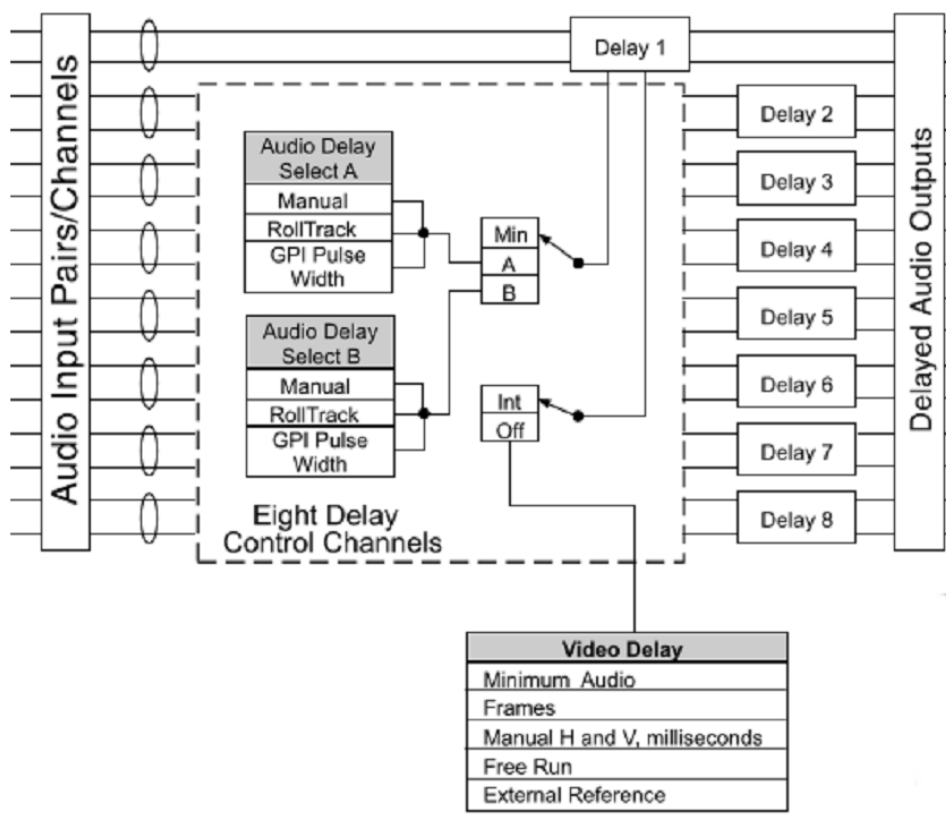

Each of the delay blocks is limited, if the requested delay is too low, to 3 ms for PCM or 0.75 ms for data signals. When a delay block is being limited a flag adjacent to it will show "LO".

Having two delay controls is a unique feature that allows audio to be timed to, or synchronized with, one of two separate timing planes. Options are: having no audio delay, having all the audio delayed together, having some audio delayed and some not. Using both delay controls however (A for one and B for the other) it is possible to choose some audio pairs delayed by a different amount than others.

The delays are SMPTE-337 data aware, and as such will attempt to rack any changes during the guard bands to avoid corrupting any data packets. This limits response to changes to a rate similar to the SRC filtered case, which is entirely adequate for tracking while synchronizing video.

#### 5.14.1 Audio Delay Select - A/B

This function allows delay times (A and B) to be applied to the delay processor block. For both Audio Delay A and Audio Delay B, more than one of these drivers can be enabled simultaneously. When multiple selections are made, the resulting delay is the sum of the values from all selected drivers:

- **Manual:** Applies a manual delay set by the **Manual Course Delay** slider bar. The delay range is -40.0 ms to 2000.00 ms, adjusted in 0.25 ms steps. For finer adjustments, use the Fine Delay control, which is described below. The preset (**P**) value is 0.00 ms.
- **GPI Pulse width:** Applies a delay equal to the width of a pulse at the GPI connector.

**Note:**

An audio delay pulse of more than 500 ms, applied to the GPI Input, will be treated as invalid, resulting in the GPI delay returning to zero.

The GPI must be configured correctly for this function to operate. If set to Unused the delay will be zero.

- **RollTrack 14/15/16/17:** Applies a delay set by external RollTrack commands. RollTracks are signals sent between pieces of equipment so that they can work together in concert. For example two modules can exchange delay values through the RollTrack system. The delay used for the audio passing through this remultiplexer module could be set for example, by the delay through a video synchronizer. Delay values can be applied via RollTracks 14, 15, 16 and 17. For more details, see "RollTrack Audio Delay Tracking" on page 61.

##### 5.14.1.1 Total Delay

This indicator shows the total delay value that the control (A or B) is currently set. Any delay block being controlled by that control (A or B) will be set to this value plus the video Internal Delay (if selected). It is a useful check that the right combination of delays has been applied. It only indicates delays applied at this stage of the processing and not individual pair delays applied to the embedded audio inputs. One of the useful features is being able to see whether tracking delays are changing their value.

The minimum amount of total delay shown here will be 3.0 ms, which is the system minimum delay in PCM. Data mode is made consistent with PCM by adding 88 samples worth of delay.

##### 5.14.2 Internal Video Delay

This indicator show the unit's current internal video delay in ms.

##### 5.14.3 Smooth Delay Limit

Under normal circumstances, when audio tracks video, it slowly creeps up to track with video. Sometimes however, it may be preferable to have the audio immediately jump to the tracking point. The Smooth Delay Limit slider adjusts the time that it takes for the audio to sync with the video.

The range of this control is 0ms to 80 ms. The preset value is 80 ms.

### 5.14.4 Embed Delay 1 to 8

This displays the controls for each of the embedded delay blocks. For each delay block the delay can be derived from one of the following settings:

- **Min:** Effectively zero delay but when no Internal delay is added it is limited to the minimum audio delay of approx. 0.75 ms or 3 ms if via a SRC.
- **A:** The delay time for this audio pair is the value set by the Audio Delay Select-A control.
- **B:** The delay time for this audio pair is the value set by the Audio Delay Select-B control.
- **V:** Adds an audio delay equal to the unit's video Internal Delay when enabled.
- **Fine Delay:** Specifies manual delays finer than 0.25 ms (the adjustment increment of the Manual Coarse Delay control). The delay specified by this control is added to the value set with the Manual Coarse Delay control. The delay range is 0 ms to 0.244 ms in 5 ms to 6 ms steps. The preset (**P**) value is 0.00 ms.
- **Fine (+A|B +V)=Total:** This displays the total of the A or B delay time, plus any manual fine delay, plus the internal video delay.
- **Limit:** If **LO** appears to the right of the check boxes, the delay set is lower than the minimum delay (0.75 ms or 3.0 ms). If **HI** appears to the right, the current total value exceeds 2.6 seconds, values greater than this are capped at 2.6 seconds.
- **Auto DE:** When selected, the unit alters the audio delay by up to half a frame to automatically place the Dolby E header on the same line as specified by the Dolby E Auto Line No control on the Dolby E Auto Line page.

**Note:**

If Dolby E is asynchronous to the output video, but synchronous to the input video, the **Int** control should also be selected so that the delay of the Dolby E tracks the video delay and whole frames of Dolby E are dropped with the video frames.

A Dolby E audio source synchronized using the V compensation setting may perform poorly when the total audio delay, including the alignment compensation (up to  $\pm 0.5$  frames), goes below the normal minimum audio delay for data (i.e. 0.75ms). This is a cyclical effect and depends also on the level of incoming video and audio signal misalignment. Hence, when synchronizing with Dolby E alignment, set **Video Delay Frames** to 1 or greater to allow optimum tracking of the Dolby E header position.

### 5.14.5 Reliable Audio Alignment - Use Cases

There are two possible use cases, which should be treated differently:

- **Input Lines Case:** Video input needs firewalling and synchronizing to meet the requirements of the facility. Auto alignment will operate once the video has settled to bring the selected Dolby E streams onto location. Depending on the error magnitude, the time to reach alignment may be up to 6 seconds. Since the source changes in advance of usage there is no problem with switching or recording downstream.
- **Playout Chain Case:** An IQSYN22 is used as a post-switch firewall in an agile setting. Use of Mixed mode, whilst disabling procamps, provides for clean switching between PCM and Data such as Dolby E. Provided that the decoder can change modes cleanly it is possible to have a "hot" switch between types without any mute or disturbance. Since PCM has no alignment requirement, the Auto DE controller will allow the audio delay to drift to the actual requested delay when PCM is detected, and a switch back to a Dolby E source will give some misalignment error during the Auto DE recovery time - and probably a decoder mute. For this reason it is essential that a pre-switch alignment firewall is used on the Dolby E source(s), and that the PCM delay is set to the nominal delay for correct alignment - probably an integer number of frames.

There are additional controls which should be selected for reliable operation in the presence of other ancillary data, in particular for standard definition video:

- **Embedder Priority (Embed On/Off page)** should be set to Audio. This will prioritise audio packet insertion so the requested line is always available.
- **Use Embedded Reader (Dolby E Auto Line page)** should be enabled. This allows the automatic alignment adjustment to be made using the actual embedded data to ensure the requested line is achieved.

**Note:**

**720p compatibility limitation.** Where the video standard frame rate is a multiple of the embedded Dolby E frame rate (e.g. 525/29i locked Dolby E within 720/59p video,) it is not possible to align the Dolby E correctly to the video while synchronizing. There is an ambiguous relationship between the video and Dolby E frames, and the synchronizing of the video frames at a higher rate causes mismatched delay discontinuities which can corrupt the audio.



### 5.15 ANC Blank & Bridge

The **ANC Blank & Bridge** screen allows the line position of various signaling functions to be selected, and the detection and re-insertion of packet-based ancillary data on the output. This should not be used for packet types already processed (708, OP47, SMPTE2016, SMPTE2031, ATC) by the ancillary data block. The exception is in processing SD-ATC, where you should use the bridge.

The ancillary bridge provides a generic bridging mechanism to forward packets from input to output. Up to 7 blocks can be configured; each block processes 1 field's worth of data. If data is present, the detected line is indicated (in the **Input Control** area) and whether this is located in VANC or HANC (in the **Detection** area). The use may optionally program the output on any available line (in the **Output Control** area), although other ancillary packets may also use the same line (concatenated). This rule works except for 2016 output which must be left on its own line).

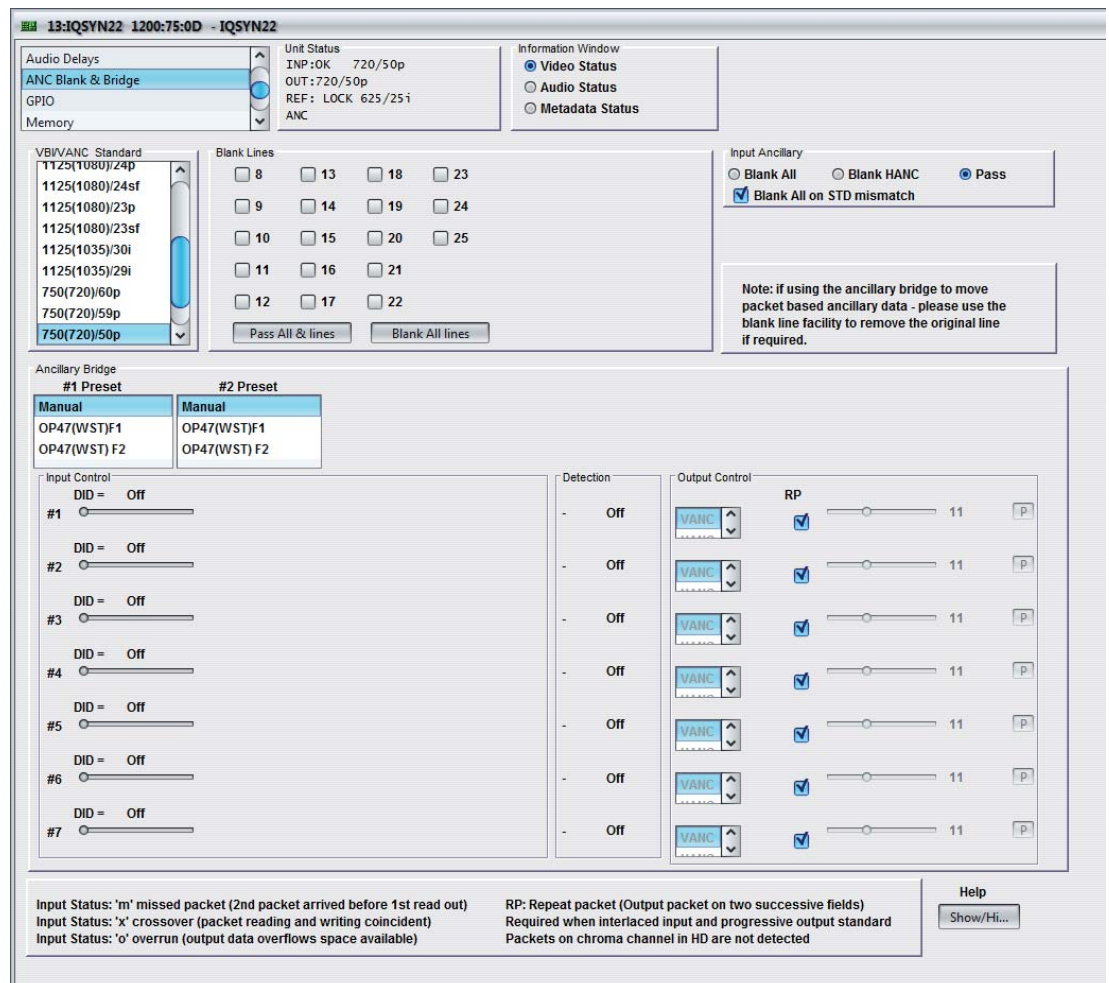

#### 5.15.1 VBI/VANC Standard

This item allows the Vertical Interval data (all or specific lines) contained in the input signal to be blanked or passed through the module. It allows the selection of which vertical interval lines to pass through to the output and which lines to blank.

Different standards will display different VBI lines.

### 5.15.2 Blank Lines

To prevent specific lines from being passed to the output signal, select them from the **Blank Lines** section.

To allow all displayed vertical interval lines to be passed to the output signal, click **Pass All Lines**.

To prevent all displayed vertical interval lines from being passed to the output signal, click **Blank All Lines**.

### 5.15.3 Input Ancillary

The Input Ancillary controls enable you to specify whether to pass or blank ancillary data:

- **Blank All:** When selected, remove all ancillary data. This overrides the VBI Blank Lines control.
- **Blank HANC:** When selected, removes horizontal ancillary data (HANC).
- **Pass:** When selected, enables ancillary data to pass unaltered. The pass-through operations will not alter audio packets for groups that the IQSYN22 has not selected for embedding.
- **Blank All on STD mismatch:** When checked, removes all ancillary data, if the input signal fails to match the output standard.

**Note:** Embedded audio (as enabled for embedding) and EDH controls are not affected by these controls.

### 5.15.4 Ancillary Bridge

These are 7 preset data stores, labelled **#1 Preset** to **#7 Preset**, that display any detected ancillary data packets in the input. Each store configures 1 “block” or “field” of data.

There are 5 possible options:

- **Manual:** User configures DID and, optionally, SDID values.
- **PID:** (44,04).
- **UMID:** (44,44).
- **Dolby Audio metadata:** SMPTE2020 (E3).
- **OFF:** Turns off any enabled controls.

#### 5.15.4.1 Input Control

Displays detected DID or SDID at the input for each of the ancillary data blocks displayed in the above preset stores.

#### 5.15.4.2 Detection

If data is present, displays the detected line and whether this is located in VANC or HANC.

#### 5.15.4.3 Output Control

Displays the output lines in which the ancillary data is re-inserted.

## 5.16 GPIO

The **GPIO** screen enables the General Purpose Input/Output functions to be configured.

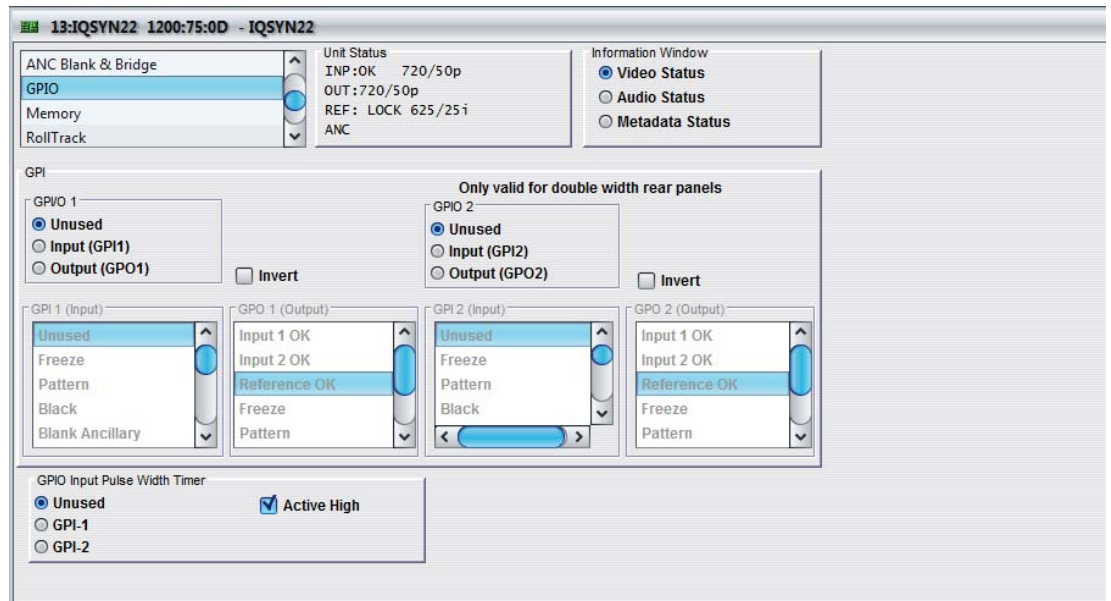

### 5.16.1 GPIO 1 and GPIO 2

This enables GPIO ports to be configured:

- **Unused:** The GPIO port is inactive.
- **Input:** The GPIO port is configured as an input.
- **Output:** The GPIO port is configured as an output.

**Note:** GPIO 2 is only valid for the double-width module.

### 5.16.2 GPI 1 (Input) or GPI 2 (Input)

When the GPI is configured as an input, this item allows an action to be chosen that will occur when the GPI input is grounded or, if the Invert function is selected, becomes open.

Each of the following options is initial edge triggered. Once this has taken place, the option will be selected until some other process, or (where applicable) the returning edge, deems otherwise.

The options are as follows:

- **Unused:** This enables a direct GPI to RollTrack without calling the other states.
- **Freeze:** The output picture is frozen. When released (input open) the output picture becomes unfrozen.
- **Pattern:** The output picture becomes the selected pattern. When released (input open) the output picture reverts to normal.
- **Black:** The output picture cuts to black. When released (input open) the output picture reverts to normal.
- **Blank Ancillary:** The ancillary data is blanked. When released (input open) ancillary data will be passed.
- **MonoChrm Y Only:** The output picture becomes monochrome using only the Y component of the signal. When released (input open) the picture reverts to normal color.

- **MonoChrm CbCr Only:** The output picture becomes monochrome using only the CbCr components of the signal. When released (input open) the picture reverts to normal color.
- **Use I/P Ref (SDI):** When initiated, the unit locks to the video input. When released (input open) this state remains, i.e. it does not revert to the previous state.
- **Use Ext Ref (Analog):** When initiated, the unit locks to the reference signal. When released (input open) this state remains, i.e. it does not revert to the previous state.
- **Select Inp 1, Select Inp 2:** Input 1 or Input 2 is selected.
- **Select Input:** A toggle function that selects between Input 1 (inactive) and Input 2 (active).
- **Select Backup:** Enables the Backup Rules function.

**Note:** **GPI Input Edge Switching Operation.** With the exception of reference actions, the GPI input will switch on both edges, hence the switch to the inactive state will perform the reverse function. This may obviously override any other control operations performed while the GPI was active.

### 5.16.3 GPI 1 (Output) and GPI 2 (Output)

When the GPI is configured as an output, this item allows an action to be chosen that will produce an output signal at the GPI connector. The GPI output will be driven to ground or, if the Invert function is selected, becomes open.

The options are as follows:

- **Input 1/2 OK:** An output signal is produced if the HD SDI input is present and OK.
- **Reference OK:** An output signal is produced if the reference signal is present and OK.
- **Freeze:** An output signal is produced when freeze is selected.
- **Pattern:** An output signal is produced when patterns are enabled.
- **Black:** An output signal is produced if the picture has become cut to black.
- **Monochrome:** An output signal is produced if the picture has become a monochrome picture.
- **Input 2 Selected:** An output signal is produced if Input 2 is selected.

### 5.16.4 GPIO Input Pulse Width Timer

The audio delay may be controlled by the width of a pulse on the GPI input.

**Note:** If a GPIO is used for any other input or output, it cannot be selected as a GPIO Input Pulse Width Timer and the option to specify it as such will not be available.

- **Unused:** The function is not active.
- **GPI-1:** Function is active on GPI 1 port.
- **GPI-2:** Function is active on GPI 2 port.
- **Active High checked:** Delay time while input is high.
- **Active High Unchecked:** Delay time while input is low.

### 5.16.5 GPIO Interface Circuitry

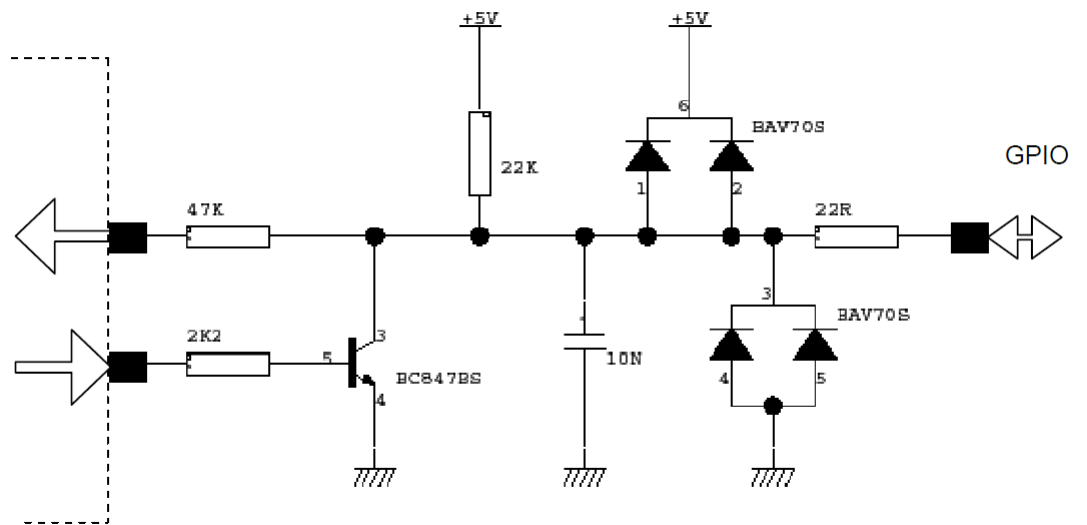

### 5.17 Memory

The **Memory** screen enables up to 16 setups to be saved and recalled later.

Default memory names can be changed to provide more meaningful descriptions.

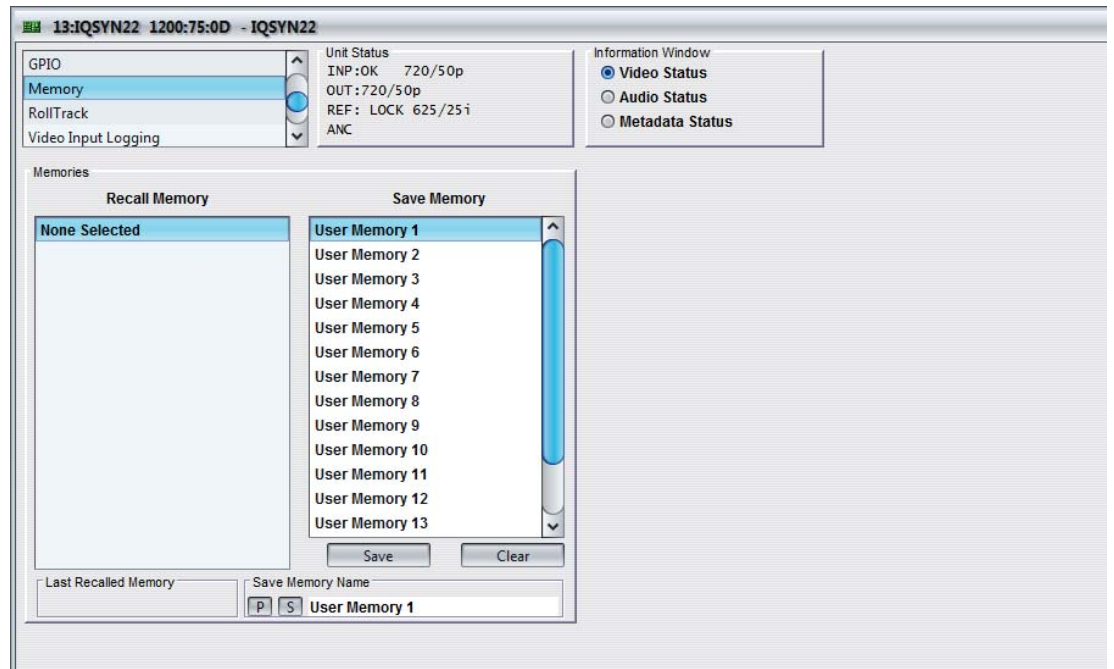

#### 5.17.1 Recall Memory

This column lists the settings that have been previously saved. If no settings have been saved, **None Selected** is displayed.

To recall the settings saved in a memory:

In the **Recall Memory** column, select the memory to recall by clicking on it. The recalled settings will be applied and the memory name will appear in the **Last Recalled Memory** section.

**Note:** User memories do not recall log field states. I.e., whether a log value has been enabled or disabled.

#### 5.17.2 Save Memory

This column lists the 16 pre-set memory names that are available for use.

To save settings:

In the **Save Memory** column, select a memory location, and then click **Save**. The current settings are saved and the memory appears in the **Recall Memory** column.

To clear a memory location:

In the **Save Memory** column, select a memory location, and then click **Clear**. The current settings stored for that memory are cleared. After you clear a memory location, it disappears from the **Recall Memory** list.

#### 5.17.3 Last Recalled

The **Last Recalled** pane displays the most recently recalled memory. If any of the settings have been changed since it was recalled, an asterisk will be displayed after the memory name.

#### 5.17.4 Save Memory Name

This option enables the pre-set memory names to be changed (to something more memorable or meaningful), if required.

To change a memory name:

In the **Save Memory Name** field, type the new memory name, and then click the **S** button. To return the memory to its default preset value, click **P** button.



## 5.18 RollTrack

The **RollTrack** screen allows information to be sent, via the RollCall™ network, to other compatible units connected on the same network.

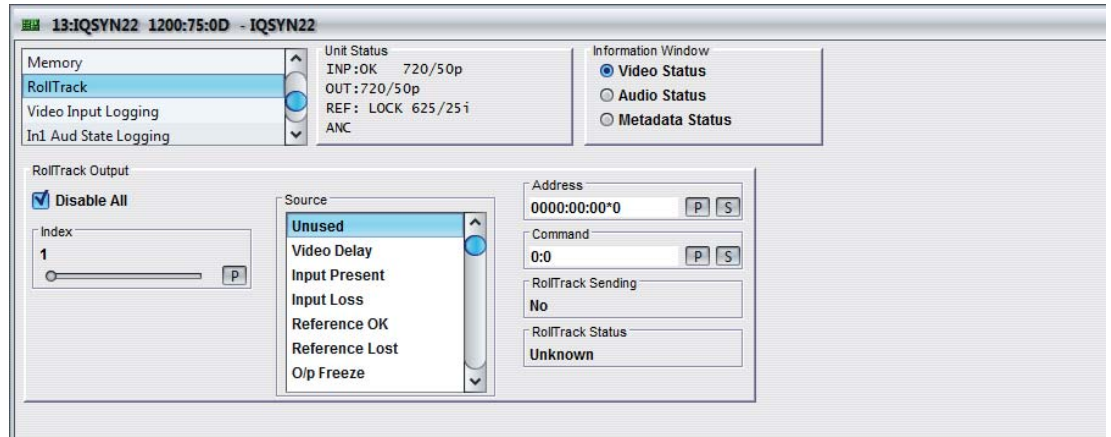

### 5.18.1 Disable All

When checked, all RollTrack items are disabled.

### 5.18.2 RollTrack Index

This slider enables up to 16 RollTrack outputs to be setup. Dragging the slider selects the RollTrack Index number, displayed below the slider. Clicking the **P** button selects the default preset value.

### 5.18.3 RollTrack Source

This slider enables the source of information that triggers the transmission of data to be selected. Dragging the slider selects the RollTrack source, displayed below the slider. Clicking the **P** button selects the default preset value. When no source is selected, **Unused** is displayed.

<b>Unused</b>	No RollTracks sent.
<b>Video Delay</b>	Output tracking delay, used to slave another module to the internal video delay of this unit, continuously sent. In this case, the Command first value (channel) is normally 14-17, and the second value is ignored because a dynamic value is sent.
<b>Input Present</b>	The video input is recognized, and valid as determined by the <b>In/Out std. Mismatch</b> and <b>Valid Input Standards</b> settings.
<b>Input Loss</b>	Video input is missing or invalid as determined by the <b>In/Out std. Mismatch</b> and <b>Valid Input Standards</b> settings.
<b>Reference OK</b>	Reference is present and valid as required by the current Genlock mode. <ul style="list-style-type: none"> <li>• If not used, as in <b>Free-run</b>, this is always true.</li> <li>• In <b>Lock to Input</b>, this will be active if video input is valid.</li> <li>• In <b>Lock to Reference</b> mode this will be active if the external reference signal is present and is correctly locked to.</li> </ul>
<b>Reference Lost</b>	Reference is missing or invalid, as required by the current Genlock mode.

<b>O/P Freeze</b>	Freeze is applied manually, or by input loss, or invalid as determined by the <b>In/Out Std. Mismatch</b> and <b>Valid Input Standards</b> settings.
<b>INP1/2 Select</b>	RollTrack is sent on selection of Input 1 or Input 2.
<b>GPI1/2 High</b>	Send when Unused or Input, and either Invert set and GPI Low or Invert not set and GPI High.
<b>GPI1/2 Low</b>	Send when Unused or Input, and either Invert set and GPI Low or Invert not set and GPI High.
<b>GPI1/2 InActive</b>	GPIO 1 or GPIO2 unused or is set as Output.
<b>De-embed 1-8 PCM Present</b>	Embedded pair 1-8 is present and valid on incoming PCM.
<b>De-embed 1-8 Data Present</b>	Embedded pair 1-8 is present and valid on incoming data.
<b>De-embed 1-8 Lost</b>	Embedded pair 1-8 is missing, or incoming video is missing / invalid.
<b>Out (video standard)</b>	Send when the specified output standard is detected

#### 5.18.4 RollTrack Address

This item enables the address of the selected destination unit to be set.

The address may be changed by typing the new destination in the text area and then selecting the **S** button to save the selection. Clicking the **P** button returns to the default preset destination.

The RollTrack address consists of four sets of numbers, for example, **0000:10:01\*99**.

- The first set (**0000**) is the network segment code number.
- The second set (**10**) is the number identifying the (enclosure/mainframe) unit.
- The third set (**01**) is the slot number in the unit.
- The fourth set (**99**) is a user-settable number that is a unique identification number for the destination unit in a multi-unit system. This ensures that only the correct unit will respond to the command. If left at 00 an incorrectly fitted unit may respond inappropriately.

#### 5.18.5 RollTrack Command

This item enables a command to be sent to the selected destination unit.

The command may be changed by typing a code in the text area and then selecting the **S** button to save the selection. Clicking the **P** button returns to the default preset command.

The RollTrack command consists of two sets of numbers, for example: **84:156**.

- The first number (**84**) is the actual RollTrack command.
- The second number (**156**) is the value sent with the RollTrack command.

### 5.18.6 RollTrack Sending

A message is displayed here when the unit is actively sending a RollTrack command. Possible RollTrack Sending messages are:

<b>String</b>	A string value is always being sent.
<b>Number</b>	A number value is always being sent.
<b>No</b>	The message is not being sent.
<b>Yes</b>	The message is being sent.
<b>Internal Type Error</b>	Inconsistent behavior. Please contact your local Snell agent.

### 5.18.7 RollTrack Status

A message is displayed here to indicate the status of the currently selected RollTrack index. Possible RollTrack Status messages are:

<b>OK</b>	RollTrack message sent and received OK.
<b>Unknown</b>	RollTrack message has been sent but it has not yet completed.
<b>Timeout</b>	RollTrack message sent but acknowledgement not received. This could be because the destination unit is not at the location specified.
<b>Bad</b>	RollTrack message has not been correctly acknowledged at the destination unit. This could be because the destination unit is not of the type specified.
<b>Disabled</b>	RollTrack sending is disabled.

## 5.19 Logging

Information about several parameters can be made available to a logging device that is connected to the RollCall network.

Each logging screen comprises three columns:

- **Log Enable:** Select the check boxes that correspond to the parameters for which log information should be collected.
- **Log Field:** Displays the name of the logging field.
- **Log Value:** Displays the current log value.

### 5.19.1 Video Input Logging

The **Video Input Logging** screen displays the current log information for the relevant video inputs.

The screenshot shows the 'Video Input Logging' screen. At the top, there's a title bar '13: IQSYN22 1200:75:0D - IQSYN22'. Below it, a 'RollTrack' menu is open to 'Video Input Logging'. To the right, 'Unit Status' shows 'INP:OK 720/50p', 'OUT:720/50p', 'REF: LOCK 625/25 i', and 'ANC'. An 'Information Window' has radio buttons for 'Video Status' (selected), 'Audio Status', and 'Metadata Status'. The main area is a table with columns 'Log Enable', 'Log Field', and 'Log Value'.

Log Enable	Log Field	Log Value
<input checked="" type="checkbox"/>	Input 1 Type	INPUT_1_TYPE=
<input checked="" type="checkbox"/>	Input 1 Status	INPUT_1_STATE=
<input checked="" type="checkbox"/>	Input 1 Std.	INPUT_1_STANDARD=
<input checked="" type="checkbox"/>	Input 1 Errors	INPUT_1_SDI_ERRS=
<input checked="" type="checkbox"/>	Input 1 ErrSecs	INPUT_1_SDI_ERRSEC=
<input checked="" type="checkbox"/>	Input 1 ANC Errors	INPUT_1_SDI_ANC_ERRS=
<input checked="" type="checkbox"/>	Input 1 ANC ErrSecs	INPUT_1_SDI_ANC_ERRSECS=
<input checked="" type="checkbox"/>	Input 2 Type	INPUT_2_TYPE=
<input checked="" type="checkbox"/>	Input 2 Status	INPUT_2_STATE=
<input checked="" type="checkbox"/>	Input 2 Std.	INPUT_2_STANDARD=
<input checked="" type="checkbox"/>	Input 2 Errors	INPUT_2_SDI_ERRS=
<input checked="" type="checkbox"/>	Input 2 ErrSecs	INPUT_2_SDI_ERRSEC=
<input checked="" type="checkbox"/>	Input 2 ANC Errors	INPUT_2_SDI_ANC_ERRS=
<input checked="" type="checkbox"/>	Input 2 ANC ErrSecs	INPUT_2_SDI_ANC_ERRSECS=

### 5.19.2 In1/2 Aud State Logging

The **In1/2 Aud State Logging** screens display the state log values for the embedded audio on each input.

The screenshot shows the 'In1 Aud State Logging' screen. The 'RollTrack' menu is open to 'In1 Aud State Logging'. The 'Unit Status' and 'Information Window' are the same as in the previous screenshot. The main area is a table with columns 'Log Enable', 'Log Field', and 'Log Value'.

Log Enable	Log Field	Log Value
<input checked="" type="checkbox"/>	Input 1 Emb.Pair 1 state	INPUT_1_EMBEDDED_AUDIO_1_STATE=
<input checked="" type="checkbox"/>	Input 1 Emb.Pair 2 state	INPUT_1_EMBEDDED_AUDIO_2_STATE=
<input checked="" type="checkbox"/>	Input 1 Emb.Pair 3 state	INPUT_1_EMBEDDED_AUDIO_3_STATE=
<input checked="" type="checkbox"/>	Input 1 Emb.Pair 4 state	INPUT_1_EMBEDDED_AUDIO_4_STATE=
<input checked="" type="checkbox"/>	Input 1 Emb.Pair 5 state	INPUT_1_EMBEDDED_AUDIO_5_STATE=
<input checked="" type="checkbox"/>	Input 1 Emb.Pair 6 state	INPUT_1_EMBEDDED_AUDIO_6_STATE=
<input checked="" type="checkbox"/>	Input 1 Emb.Pair 7 state	INPUT_1_EMBEDDED_AUDIO_7_STATE=
<input checked="" type="checkbox"/>	Input 1 Emb.Pair 8 state	INPUT_1_EMBEDDED_AUDIO_8_STATE=

### 5.19.3 In1/2 Aud Type Logging

The **In1/2 Aud Type Logging** screens display the type log values for the embedded audio on each input.

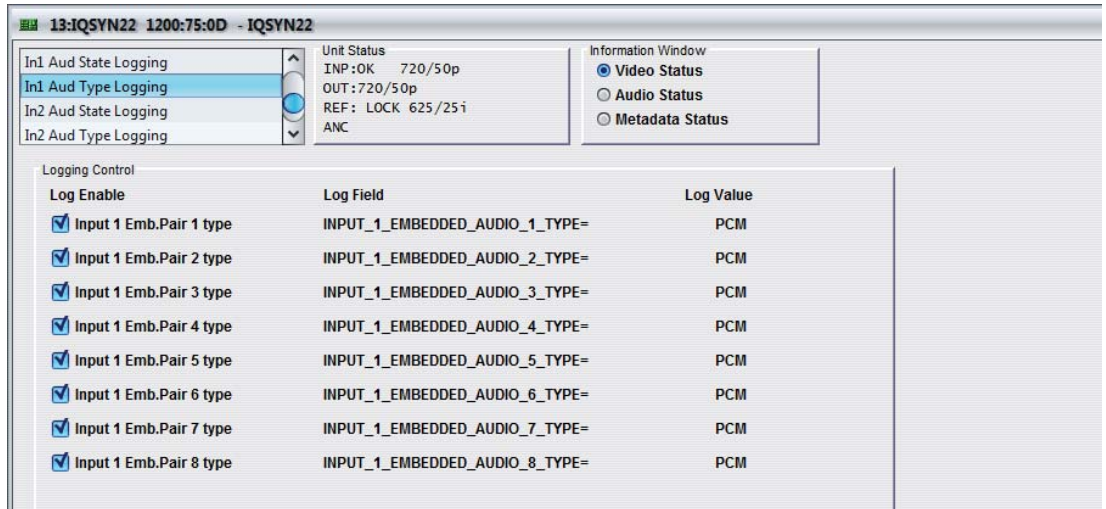

### 5.19.4 O/P Aud Level Logging

The **O/P Aud Level Logging** screen displays the current log information for the level of the embedded audio output.

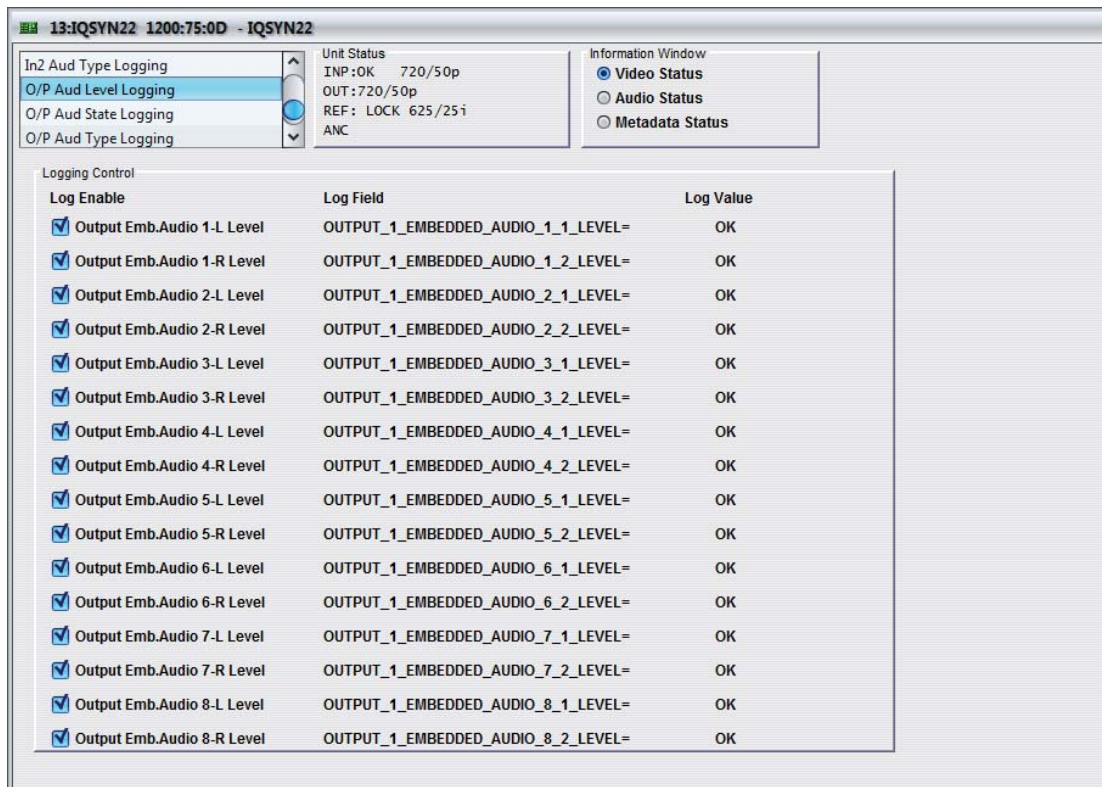



### 5.19.5 O/P Aud State Logging

The **O/P Aud State Logging** screen displays the current log information for the state of the embedded audio output.

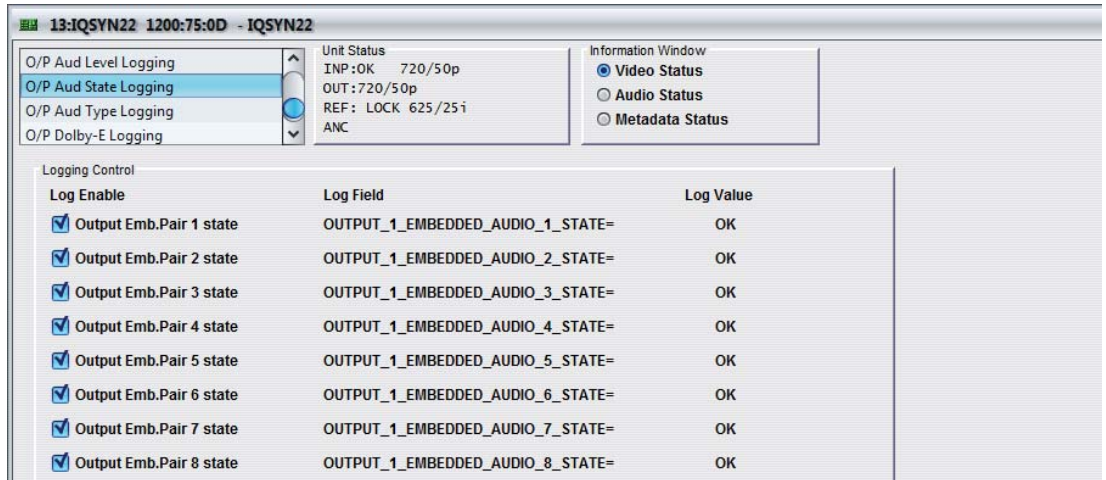

### 5.19.6 O/P Aud Type Logging

The **O/P Aud Type Logging** screen displays the current log information for the type of the embedded audio output.

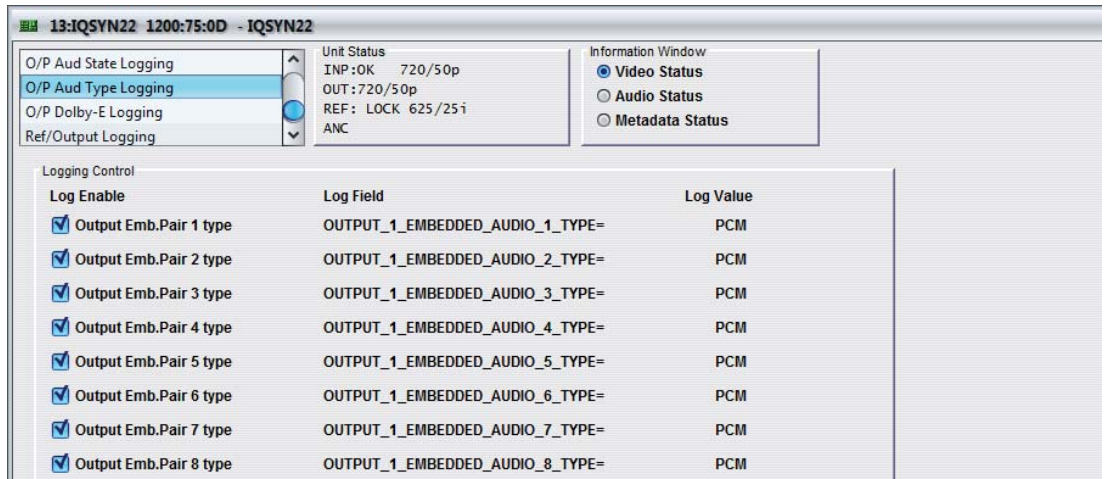

### 5.19.7 O/P Dolby E Logging

The **O/P Dolby E Logging** screen records the presence of Dolby E signals, and their timing, with respect to the video.

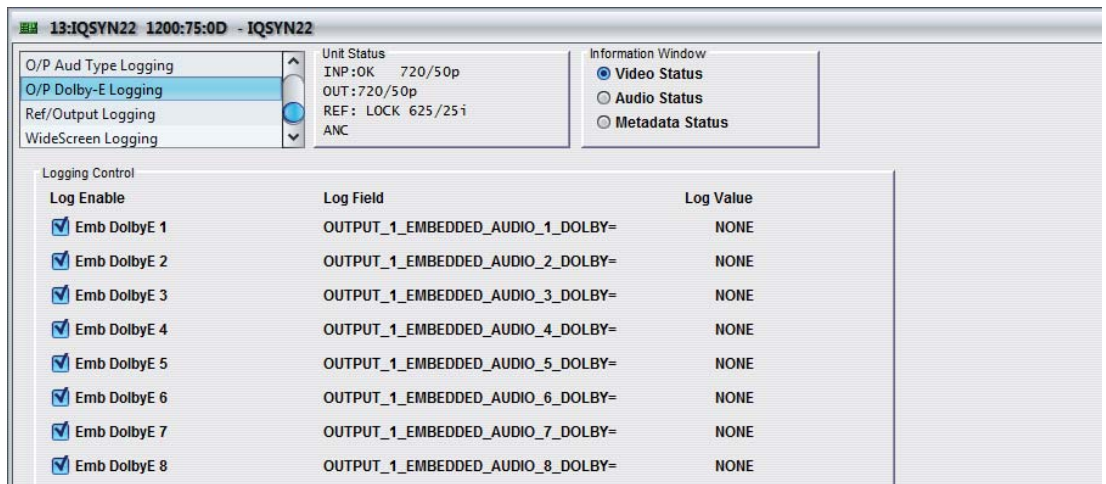

### 5.19.8 Ref/Output Logging

The **Ref/Output Logging** screen displays the current log information for the status of the video output and the reference signal.

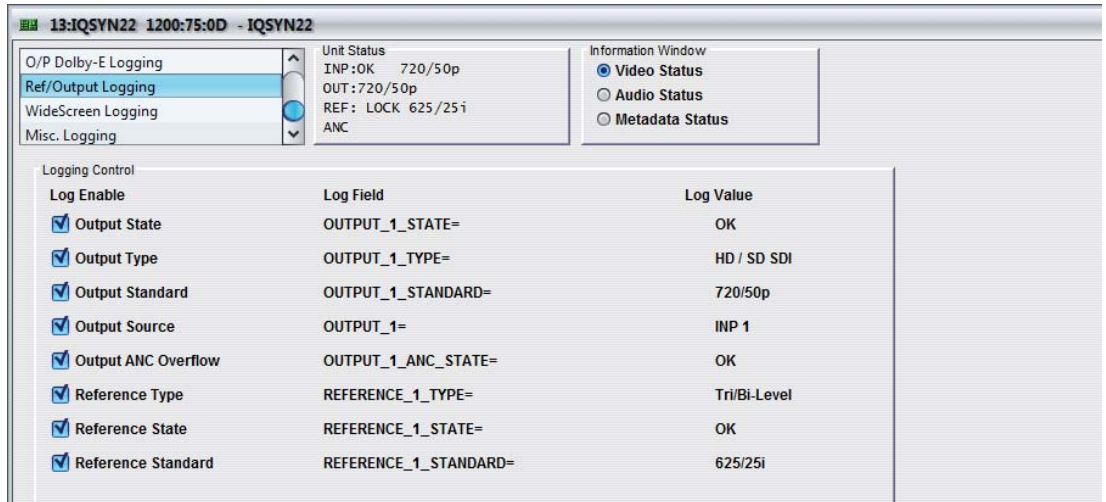

### 5.19.9 Misc. Logging

The **Misc. Logging** screen displays the current log information about the unit's basic parameters.

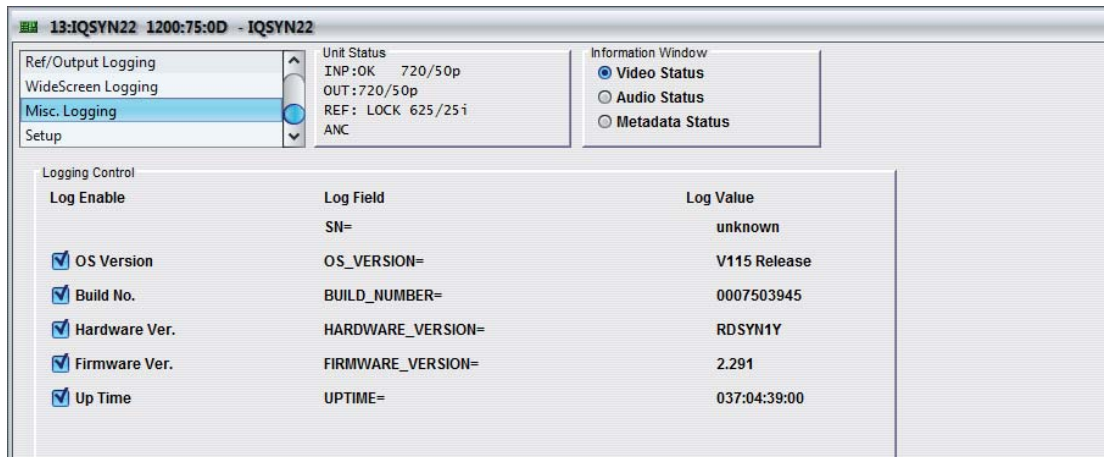



### 5.19.10 Log Field Descriptions

Log Field	Description
INPUT_N_TYPE=	This displays the type of input as specified by the unit's configuration. Valid values are HD /SD SDI.
INPUT_N_STATE=	Displays the current input state. Valid values are: <ul style="list-style-type: none"> <li>• OK</li> <li>• WARN:Mismatch</li> <li>• FAIL:Lost</li> <li>• FAIL&gt;Error</li> </ul> <p><b>Note:</b> WARN:Mismatch indicates that the input and output standards are not the same.</p>
INPUT_N_STANDARD=	This displays the current input signal standard. For example, 1080/29i.  If the input standard is not recognized or supported the field will display: WARN:Unknown
INPUT_N_SDI_ERRS=	Displays SDI errors. Valid values are: <ul style="list-style-type: none"> <li>• OK</li> <li>• WARN</li> </ul>
INPUT_N_SDI_ERRSEC=	Displays the number of errored seconds since last counter reset.
INPUT_N_SDI_ANC_ERRS=	Displays ANC errors. Valid values are: <ul style="list-style-type: none"> <li>• OK</li> <li>• WARN</li> </ul>
INPUT_N_SDI_ANC_ERRSEC=	Displays the number of errored seconds since last counter reset.
INPUT_1_EMBEDDED_AUDIO_1_STATE = to INPUT_1_EMBEDDED_AUDIO_8_STATE= -----	These fields display the current embedded input audio state. Valid values are: <ul style="list-style-type: none"> <li>• UNKNOWN</li> <li>• OK</li> <li>• LOST</li> <li>• WARN:Off</li> <li>• FAIL:Lost</li> </ul>
INPUT_2_EMBEDDED_AUDIO_1_STATE= to INPUT_2_EMBEDDED_AUDIO_8_STATE=	
INPUT_1_EMBEDDED_AUDIO_1_TYPE = to INPUT_1_EMBEDDED_AUDIO_8_TYPE= -----	These fields display the current embedded input audio state. Valid values are: <ul style="list-style-type: none"> <li>• UNKNOWN</li> <li>• PCM</li> <li>• NONPCM</li> <li>• WARN:No Input</li> </ul>
INPUT_2_EMBEDDED_AUDIO_1_TYPE= to INPUT_2_EMBEDDED_AUDIO_8_TYPE=	
OUTPUT_1_EMBEDDED_AUDIO_1_1_LEVEL= to OUTPUT_1_EMBEDDED_AUDIO_8_2_LEVEL=	These fields display the current embedded input audio state. Valid values are: <ul style="list-style-type: none"> <li>• OK</li> <li>• WARN:Overflow</li> </ul>
OUTPUT_1_EMBEDDED_AUDIO_1_STATE= to OUTPUT_1_EMBEDDED_AUDIO_8_STATE=	These fields display the current embedded input audio state. Valid values are: <ul style="list-style-type: none"> <li>• OK</li> <li>• WARN:Off</li> <li>• FAIL:Lost</li> </ul>

Log Field	Description
OUTPUT_1_EMBEDDED_AUDIO_1_TYPE= to OUTPUT_1_EMBEDDED_AUDIO_8_TYPE=	These fields display the current embedded input audio state. Valid values are: <ul style="list-style-type: none"> <li>• PCM</li> <li>• NONPCM</li> <li>• WARN:No Input</li> </ul>
OUTPUT_1_EMBEDDED_AUDIO_1_DOLBY= to OUTPUT_1_EMBEDDED_AUDIO_8_DOLBY=	These fields display the current embedded input audio state. Valid values are: <ul style="list-style-type: none"> <li>• NONE</li> <li>• OK</li> <li>• WARN:EARLY</li> <li>• WARN:LATE</li> <li>• ERROR:EARLY</li> <li>• ERROR:LATE</li> </ul>
OUTPUT_N_STATE=	<ul style="list-style-type: none"> <li>• OK</li> <li>• Pattern</li> <li>• Black</li> <li>• Freeze</li> </ul>
OUTPUT_N_TYPE=	HD / SD SDI
OUTPUT_N_STANDARD=	Displays the current output video standard.
OUTPUT_N=	Displays the relevant input source for the output video.
OUTPUT_N_ANC_STATE=	Displays the current ancillary data state. <Blank>, ANC FULL.
REFERENCE_1_TYPE=	Displays the reference type. Valid values are: <ul style="list-style-type: none"> <li>• OK:Tri-Level</li> <li>• OK:Bi-Level</li> <li>• WARN:Unknown</li> </ul>
REFERENCE_1_STATE=	Displays the reference state. Valid values are: <ul style="list-style-type: none"> <li>• OK</li> <li>• FAIL:Error</li> <li>• FAIL:Lost</li> </ul>
REFERENCE_1_STANDARD=	Displays the current video standard of the reference signal. For example, 1080/59P.
INPUT_N_ASPECT=	Displays the input aspect ratio
INPUT_N_AFD=	Displays the input active format description
OUTPUT_1_ASPECT=	Displays the output aspect ratio
OUTPUT_1_AFD=	Displays the output active format description
SN=	Displays the module serial number, which consists of an S followed by eight digits.
OS_VERSION=	Displays the operating system name and version. For example, KOS V115.
BUILD_NUMBER=	Displays the build number.
HARDWARE_VERSION=	Displays the hardware version number.
FIRMWARE_VERSION=	Displays the firmware version number.
UPTIME=	Displays the time since the last restart in the format ddd:hh:mm:ss.

## 5.20 Setup

The **Setup** screen display basic information about the module, such as the serial number and software versions. Use the functions on the screen to restart the module or return all settings to their factory or default settings.

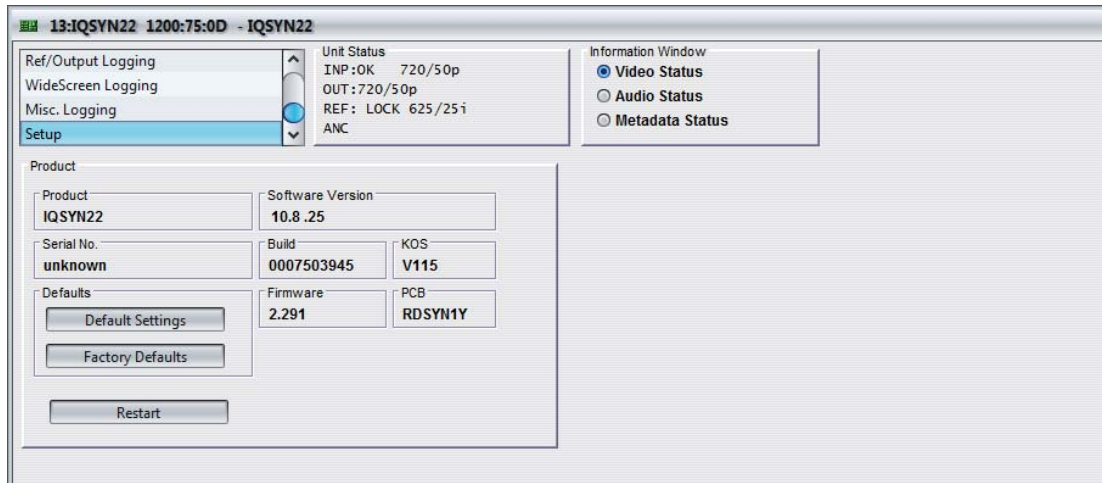

- **Product:** The name of the module.
- **Software Version:** The currently installed software version number.
- **Serial No:** The module serial number.
- **Build:** The factory build number. This number identifies all parameters of the module.
- **KOS:** The operating system version number.
- **Firmware:** The module firmware revision number.
- **PCB:** The Printed Circuit Board revision number.

### 5.20.1 Default Settings

The **Default Settings** button enables module settings to be reset to their factory defaults, leaving user memories intact.

### 5.20.2 Factory Defaults

The **Factory Defaults** button enables the module settings to be reset to their factory defaults.

**Note:** Resetting the module to its factory defaults also clears all the saved memory settings.

### 5.20.3 Restart

The **Restart** button enables the module to be rebooted, simulating a power-up/power-down cycle.

## Appendix A. RollTrack Audio Delay Tracking

### A.1 Products Featuring RollTrack™

RollTrack is a feature of RollCall™ (Snell's proprietary remote control system), that allows devices to communicate across the RollCall network with no direct user intervention.

RollTrack Audio Delay Tracking enables RollCall™ compatible audio delay products to track delay introduced by RollCall™ compatible video processing products.

The current products that implement RollTrack Audio Delay Tracking are:

Audio Delay Modules	Video Modules	Other Products	
IQBAAD	IQD1FSY	ALCHEMIST	MDD3000
IQBADC	IQDMSDS	CPP100	MDD550
IQBDAC	IQDAFS	CPP200	MDD560
IQBDAD	IQDMSDS	NRS500	MDD570
IQBSYN	IQDMSDP	HD5050	MDD2000
IQBADCD	IQDSYN		

### A.2 Configuration: Single Video Unit and Single Audio Delay

The simplest configuration is a single video unit and a single audio delay in a RollCall™ system. The audio delay will have the same delay as through the video path. If the delay changes the audio delay will track.

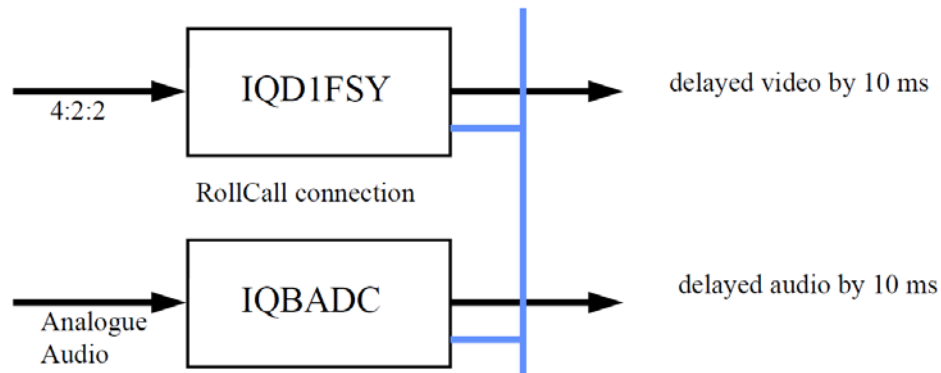

### A.3 Configuration: Multiple Video Units and Audio Delays

The next level of configuration is where there are multiple Frame Synchronizers (for example) each connected through RollCall™ to their own tracking Audio Delay. (It is worth stating that the synchronizers and audio delays do not have to be in the same enclosure; the addressing scheme, discussed later, allows for the units to be positioned anywhere in the RollCall™ domain.) The maximum number of video units and audio delays in a RollCall™ system is set by the maximum limit of the number of modules in a RollCall™ network and is currently 3840 on a single network without bridges.

The unique identification of the destination unit (a decimal number) for various modules is as follows:

Module	ID
IQBADC	51
IQBDAC	52
IQBAAD	53
IQBDAD	54

Module	ID
IQBSYN	89
IQBADCD	107

### A.4 Configuration: Vertical Delay Cluster

The next level of complexity is a vertical delay cluster where a video unit can have up to eight audio delays tracking - of the same or different types.

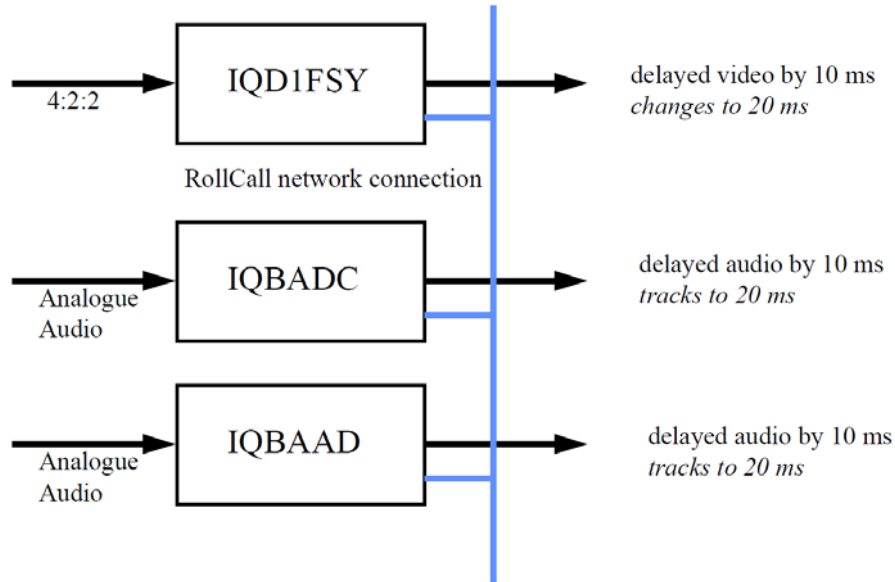

From one to eight audio delay products can be connected via RollCall™ to a single frame synchronizer, for example. If the synchronizer delay changes, then however many audio delays are connected will track the delay. The audio delays can also have a manual delay which will be added to the RollTrack delay.

### A.5 Configuration: Horizontal Delay Cluster

The next level of complexity is a horizontal delay cluster where an audio delay can track up to four video units.

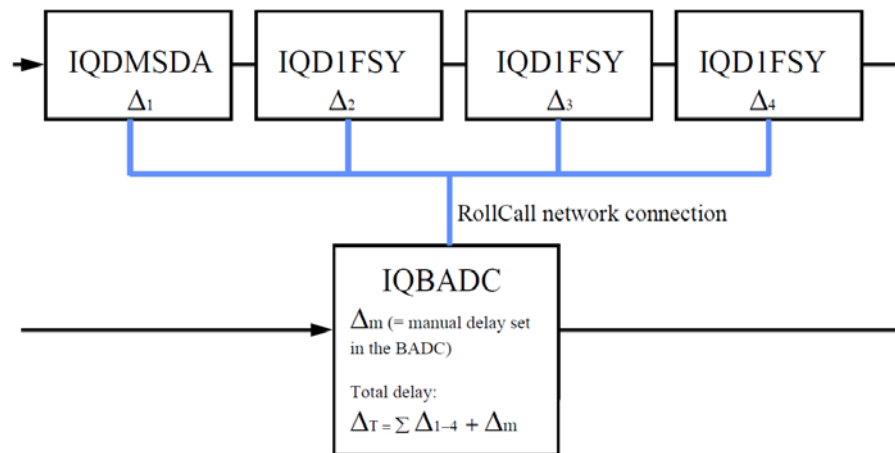

The total delay time through the audio delay is then the sum of the individual delays introduced by the video units plus the manual delay of the audio unit. The manual delay can be set to compensate for any fixed propagation delay in the video path or may be set to zero.

### A.6 Configuration: Matrix Delay Cluster

The next level of complexity is a matrix delay cluster where each audio delay (up to eight) can track up to four video units. This configuration is in effect a four by eight matrix of video units and audio delay units. The total delay time through the audio delay units is then the sum of the individual delays introduced by the video units plus the manual delay of the audio unit.

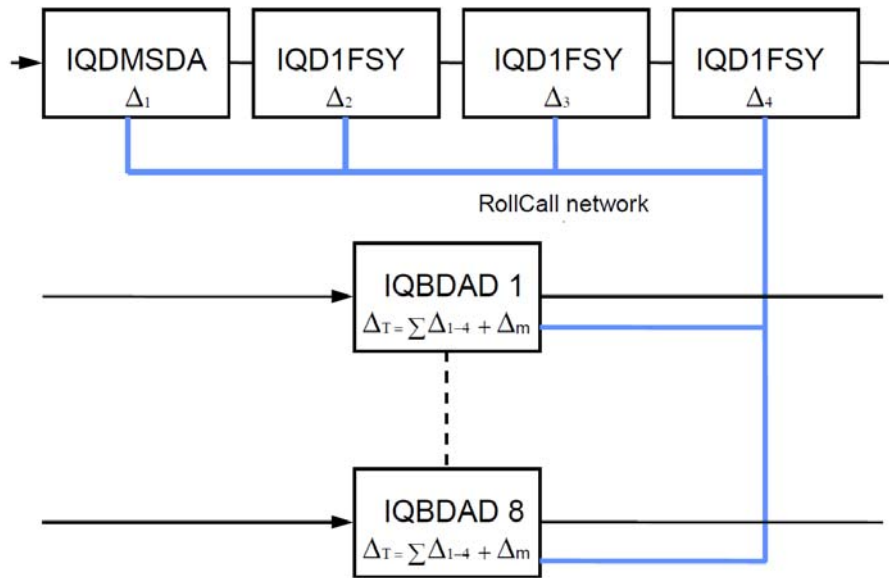

As any of the delay times change in the video path so will the audio delay time track this delay.

To make a virtual connection between from, say, an IQD1FSY to an IQBDAD:

1. Select the **Setup...** Menu of the IQD1FSY.
2. Select the **Audio\_Delay...** Menu.
3. Choosing from **Unit\_1** to **Unit\_8**.
4. Enter the unique network address of the IQBDAD in the form **nnnn:xx:yy\*z\*d**

Where:

**nnnn** = network address and in most cases will be 0000(hex)  
**xx** = IQ enclosure address (hex)  
**yy** = slot address of the IQBDAD (hex)  
**z** = the connection (or channel) number (decimal) - see table below  
**d** = the unique identification of the destination unit (decimal) The ID entered must match the receiving units own ID or else the command will be ignored. If the ID value is set to 00, the receiving unit does not perform an ID match and will always accept the incoming command

5. Select the **Delay...** Menu of the IQBDAD.
6. Select RollTrack.

**Example**

Example of Network Addresses with Channel Numbers and ID Numbers

	<b>D1FSY 1</b>	<b>D1FSY 2</b>	<b>D1FSY 3</b>	<b>D1FSY 4</b>
Audio delay 1	0000:10:01*14*54	0000:10:01*15*54	0000:10:01*16*54	0000:10:01*17*54
Audio delay 2	0000:10:03*14*54	0000:10:03*15*54	0000:10:03*16*54	0000:10:03*17*54
Audio delay 3	0000:10:05*14*54	0000:10:05*15*54	0000:10:05*16*54	0000:10:05*17*54
Audio delay 4	0000:10:07*14*54	0000:10:07*15*54	0000:10:07*16*54	0000:10:07*17*54
Audio delay 5	0000:10:09*14*54	0000:10:09*15*54	0000:10:09*16*54	0000:10:09*17*54
Audio delay 6	0000:10:0B*14*54	0000:10:0B*15*54	0000:10:0B*16*54	0000:10:0B*17*54
Audio delay 7	0000:10:0D*14*54	0000:10:0D*15*54	0000:10:0D*16*54	0000:10:0D*17*54
Audio delay 8	0000:10:0F*14*54	0000:10:0F*15*54	0000:10:0F*16*54	0000:10:0F*17*54



### A.6.1 Configuration: An Array of Matrix Clusters

The most complex system would be an array of matrix delay clusters.

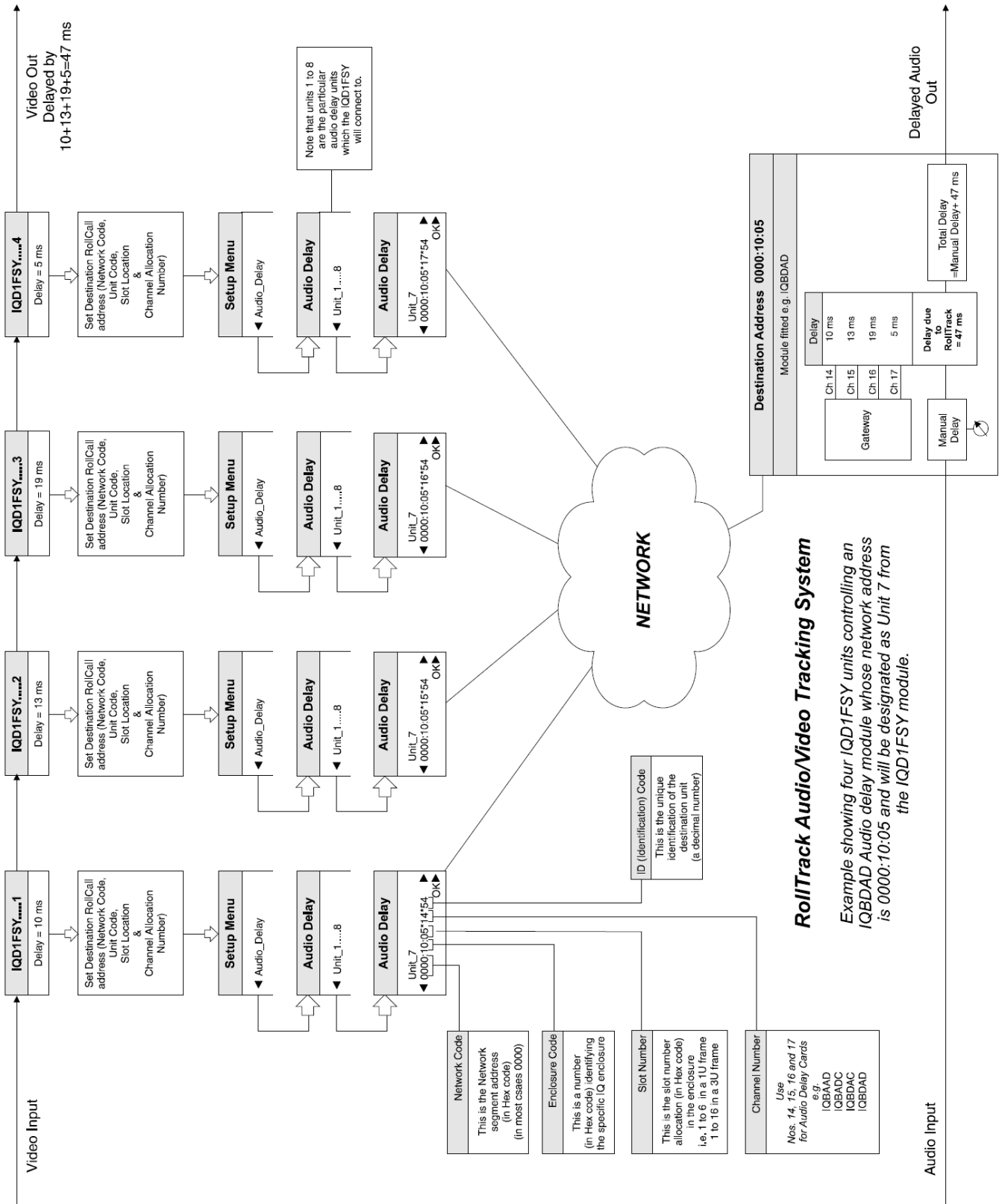

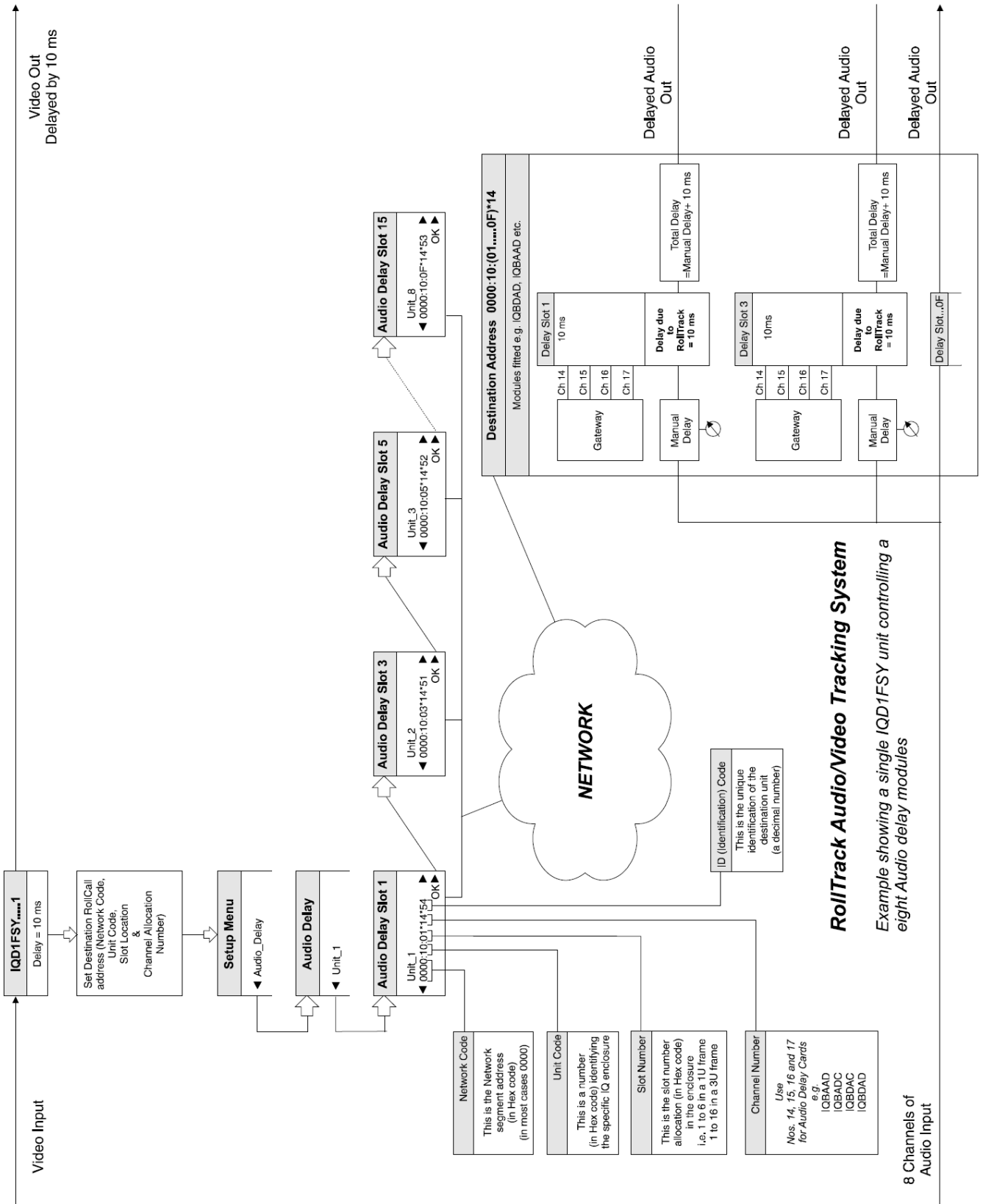

## Appendix B. Firewall

### B.1 Introduction

The firewall protects a digital signal output against propagation of errors or disruptions in the input signal. It ensures that the signal stream at that output is continuously valid no matter what happens at the input. If the input suffers any dropout, loss of data, break or discontinuity in the carrier, then this will not be reflected in the output. Default valid data will be used to pad the output stream such as video black, a freeze, or audio silence.

A firewall will not ensure the picture or audio is what you want to see or hear, of course; a corrupted signal will lead to loss of original content. A firewall will ensure, however, that valid content will get through. In short, it ensures the integrity, not the content, of the digital stream.

### B.2 How a Firewall Equipped Product Behaves

The essential behavior of a system containing a firewall is that the input to the unit containing the firewall can be removed and later replaced with another signal and during this sequence the unit following the one with the firewall will see no disturbance at its input.

### B.3 Why Use a Firewall?

Any equipment downstream of a Snell product with firewall protection can expect to be fed with a continuous input stream. Dropouts in the signal, disturbances due to switching and errors in the composition of the signal will not penetrate the firewall and will therefore not corrupt operations downstream.

The examples below illustrate where firewalls are of most benefit.

#### B.3.1 Using a Firewall at the Beginning of a Chain

Snell firewalls are excellent for use at the beginning of a chain of units, significantly improving the time to restore an output when a problem is detected at the input.

Traditionally, a damaged signal will pass through all the equipment in a chain, each unit losing lock on the signal it passes. In this scenario, the damage in the signal appears at the input of every device along the chain causing a loss of lock to be cascaded down the chain. When the input signal is restored, each unit in the chain may take a few seconds to recover. However, each unit cannot start recovery until the previous unit in the chain has locked to the signal and delivered a valid signal. Thus, even a minor problem in the input signal, such as a break in the carrier, can lead to several seconds of disruption at the output.

#### B.3.2 Using a Firewall to Protect MPEG Encoders

Placing a Snell firewall in front of MPEG encoders ensures that their operation is not disrupted in the event of a break in the incoming content.

When a break in the integrity of the input signal occurs, MPEG encoders often corrupt their output and typically take a long time to recover. Video synchronizers can help but they only protect the video. Loss of audio, in this case, will cause a loss of lock even though the integrity of the video was maintained.

For transmission encoders, disruption can mean a break in the output. For recording encoders, such as those in a video server, this can mean that the recording is lost.

### B.4 How a Firewall is Tested

A variety of equipment is used to test the firewall behavior. The test consists of analyzing the data downstream of the firewall product looking for discontinuities in the signal stream. While it is intended that all products fed by a firewall equipped unit will accept the signal as

uninterrupted, it is accepted that there is a wide variety of real-world performances. Therefore the reference product used to test whether the output streams are continuous is the Snell IQMUX01 for both AES and SDI signals.

### B.5 Performance of Firewall Equipped Products Versus Genlock Mode

The table below summarizes the behavior of products for different genlock modes:

#### Synchronizer Mode

	Referenced	Input locked	Free run
SDI Video	Firewall	No firewall	Firewall
Embedded Audio (PCM)	Firewall	No Firewall	Firewall
Ancillary Data	No Firewall	No Firewall	No Firewall

### B.6 When Firewall Protection is Not Provided

#### B.6.1 Video

A firewall protects against disruption or illegal signals at the input and not against corrupt or illegal reference provision.

**Note:** When changing genlock mode, the firewall is not maintained for the video output during the change, e.g. when changing from free-running mode to referenced mode or when the reference is adjusted or interrupted.

#### B.6.2 Audio

Embedded audio firewall protection follows the video behavior. When the video is protected then the embedded audio is also protected. See all the information relating to video firewall protection.

Only PCM signals are protected by the firewall. The non-PCM direct paths for audio do not have firewall protection.

## Appendix C. Ancillary Passing

### C.1 SMPTE 272M and 299M

The SMPTE 272M and 299M standard specifications allow for up to four groups of AES/EBU digital audio to be embedded in a component digital video SD or HD stream, respectively. Each group consists of two stereo pairs, comprising four channels, resulting in a total of sixteen audio channels for all four groups. This horizontal ancillary (HANC) data increasingly shares space with other types of ancillary data such as EDH, timecode and UMID labels making the insertion and passing a complex process.

Processing of audio by the IQSYN22 requires the reinsertion of the audio into the passed ancillary data. This is essentially separate from the extraction of audio from the input video, and allows the embedded audio to be firewalled when input disturbances force blanking of ancillary space.

For 625-line (or other 25 Hz) video, 1920 audio samples occur in each frame. For 525-line (or other 29.97 Hz) video, 8008 audio samples occur over five video frames. Audio data is distributed evenly throughout each video frame, situated in the non-active picture regions between the end of one line and the start of the next.

In SD, most lines contain three or four audio samples per active group. In HD, most lines contain one or two samples per active group. Additional lines are reserved after the SMPTE RP-168 switch points, which contain no samples. This is in contrast to most ancillary data, which resides in a fairly fixed HANC or VANC (vertical ancillary) space.

Audio Control and Extended Data packets, as defined in SMPTE 272M (SD), are not inserted by the IQSYN22. Instead, they are handled by the 'passing' and 'blanking' functions. Audio Control packets, as defined in SMPTE 299M (HD), are always inserted. Block numbering as defined in SMPTE 291M is supported.

### C.2 SMPTE 291M

The SMPTE 291M standard defines the structure and space formatting for ancillary data within digital video streams. Within HANC data space, ancillary packets follow immediately after the end of active video (EAV) marker, including line numbers in HD. They are contiguous with each other until either the end of the last packet or the start of active video (SAV) marker. Unused space is filled with black level blanking. Likewise, VANC data space follows from the SAV to the EAV markers throughout vertical blanking, which is in principal similar to vertical blanking interval (VBI) use in legacy SD environments for typically analogue data waveforms.

The IQSYN22 allows separate blanking of HANC and VBI line spaces to completely remove data stored within those spaces for when specific applications demand it.

Complying with SMPTE 291M, the embedder uses a two-stage process, as follows:

- The embedder reformats the incoming ancillary to remove unwanted data which is already marked as deleted or audio packets that are marked for removal here, for example, when blanking or reinserting. Additional packets that are always removed are EDH packets (which are always reinserted) and Start and End Marker packets (which are never reinserted). This makes for the most efficient use of the data space and gives priority to passed data.
- The new audio data and control packets are appended in the remaining space.

When Audio priority is enabled, the new audio data is inserted first, then passed data packets are appended while they still fit.

The ancillary formatter passes any data space with no recognizable ancillary packets unchanged, but will operate when it finds a packet after EAV or SAV. Data packets for passing are buffered while deleted packets are dropped. This requires a holding buffer and a delay so that all passed packets can be shuffled up earlier in the data space without gaps.

The following embed control section looks for the first free space after EAV. Once found, the embedding process is initiated with the first enabled group inserter. However, before starting the embedding for any of the inserter streams the remaining data space is checked to ensure that there is enough room for the ancillary packet. If not, the inserter is disabled to prevent corruption of the video format or generation of invalid ancillary data packets. This situation is a sample overflow which simply causes the data to be delayed until the following line. If this is repeated over many lines, there will be a full embed overflow, which is reported in the Audio Status window, on the card edge yellow Warning LED, and is logged.

Embedded ancillary data that does not conform to the space formatting requirements of SMPTE 291M may not be recognized, and so could be destroyed by the IQSYN22 card. For example, if the data packets do not start immediately following the EAV marker the inserter will overwrite the packets. Similarly, if a data packet does start in the correct place but a second packet does not immediately follow the first one the second packet will be overwritten.

To summarize:

- Marked for deletion and audio packets to be replaced, are removed from the ancillary data space for most efficient and clean use of data space.
- Ancillary packets are shuffled up within the data space during reformatting.
- Incoming ancillary data must be SMPTE 291M compliant.

# Appendix D. Audio Processing Overview

## D.1 Audio Processing Block Diagram

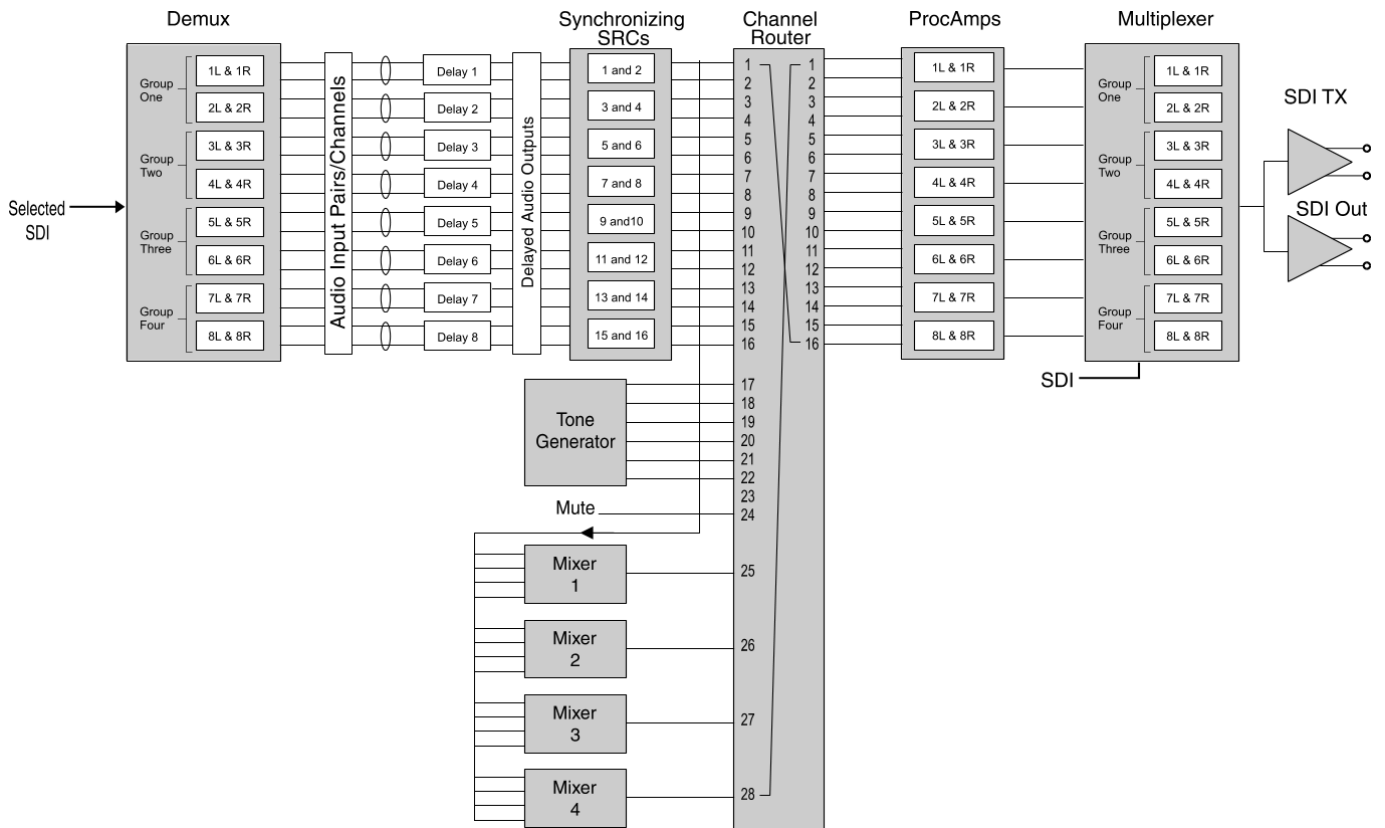

## D.2 Audio Processing – Control Panel Screens Associations

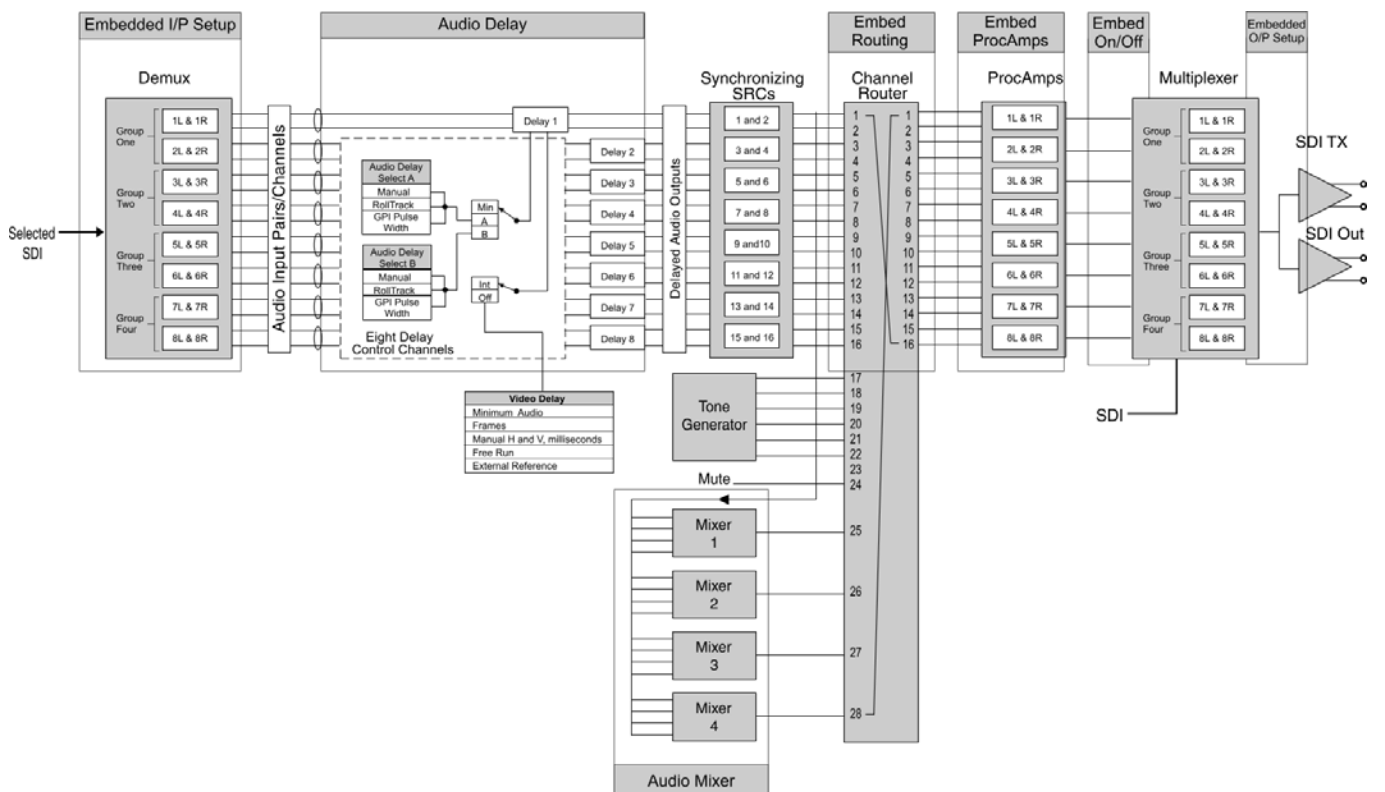



### D.3 SDI Demultiplexer

The audio channels are demultiplexed from the SDI signal as eight, 2-channel pairs that are fed to the audio delay processor.

**Note:** Embedded audio handling for HD is 24-bit synchronous 48 kHz to SMPTE 299M and SD is 20-bit synchronous 48 kHz to SMPTE 272M-A.

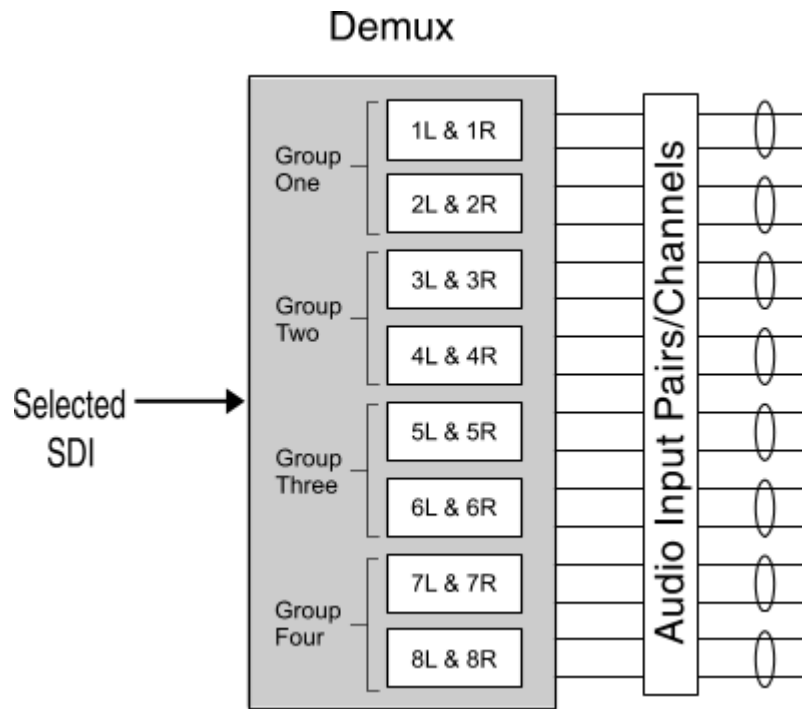

### D.4 Audio Delay Processor

The SDI demultiplexed and decoded AES signals (eight 2-channel pairs) are fed to eight separate delay blocks. Each block processes one audio pair (two channels) at the same time, the delay time being the same for both channels.

The delay time may be set to Min (the minimum audio delay of approx. 0.75 ms in Data or Mixed modes or 3.0 ms if via a SRC) or to a time set by one of two (A and B) Audio Delay Selectors. A delay equal to the units video delay may also be added by selecting Int. Audio outputs are always synchronous to the video.

The delay time set by each of these selectors is controlled by a combination of the following:

- **Manual:** A delay set by the Manual Delay control will be applied.
- **RollTrack:** A delay set by external RollTrack commands will be applied.
- **GPI Pulse Width:** A delay set by the GPI Pulse width control will be applied.

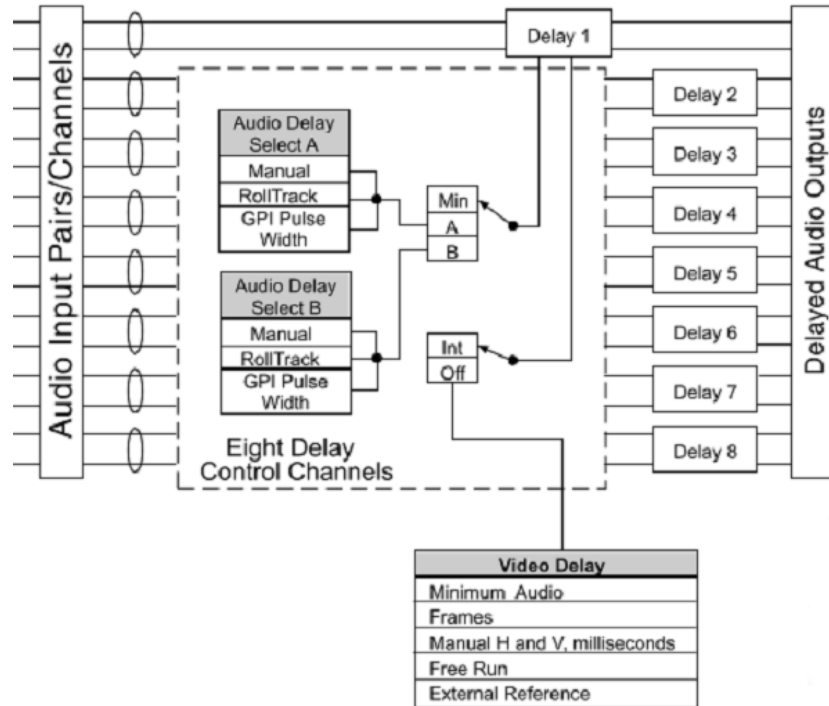

### D.5 Tone Generator

A tone generator provides the following signals to the channel router.

- 1 kHz at -20 dBFS
- 2 kHz at -20 dBFS
- 4 kHz at -20 dBFS
- 1 kHz at -18 dBFS
- 2 kHz at -18 dBFS
- 4 kHz at -18 dBFS

**Note:** The frequency and level of these signals is not adjustable.

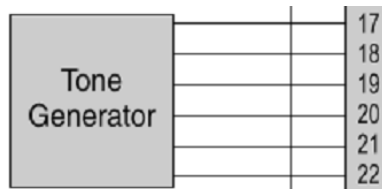

### D.6 Mixers 1 to 4

There are four separate 4 input, 1 output audio mixers available.

Each mixer has four inputs with individual gain controls that allow the mixing levels for each of the input signals, to be adjusted.

The inputs may be any of the following:

- Mute
- Disembled 1 to 8 Left/Right
- Tone Generator outputs

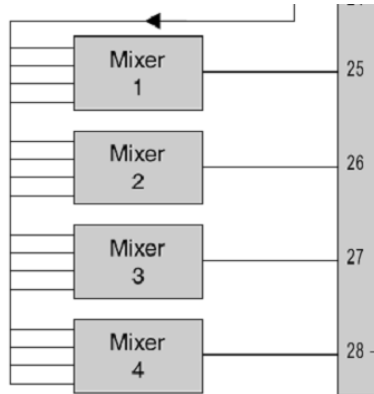

### D.7 Embedder ProcAmps

There are eight, 2-channel processing amplifiers that receive their inputs from the output of the channel router.

The two channels are processed as Left and Right with control of Gain, Inversion, Muting and a Stereo mode.

The outputs are configured as eight, 2-channel signals in four groups and these are fed to the Multiplexer where they are embedded onto the SDI signal.

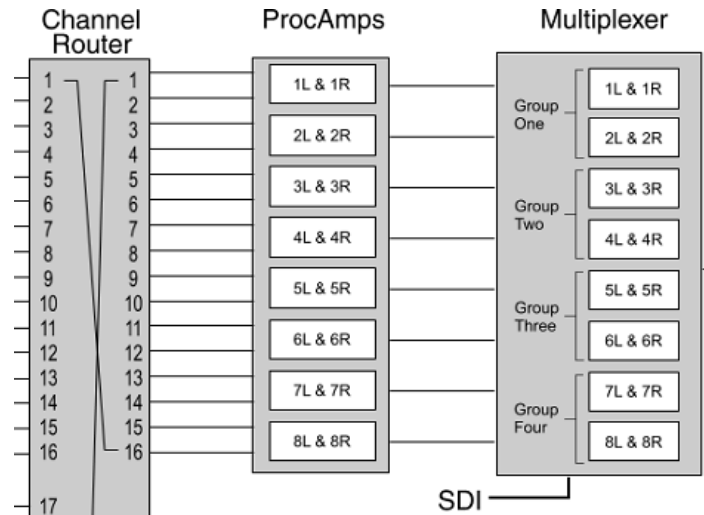

## D.8 SDI TX

The embedded SDI signal is fed to the output amplifier that provides three (-1A) or four (-2A) SDI outputs.

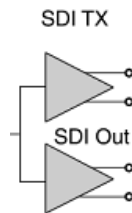

## D.9 Dolby E Audio Handling

This section describes how the IQSYN21 handles Dolby E audio. For a more general description of Dolby E and AC-3, see *Appendix E*.

Dolby E audio achieves compatibility with a digital video stream by virtue of a few fundamental features:

- The compressed audio data is broken into frame-duration packets to match the video frames it will be embedded in.
- Each frame is separated from neighboring frames by a guardband, which allows for clean video-type switching.
- Concealment of switches is possible at a decoder, based on redundant audio and block counts in each frame.

However, there is a burden in dealing with a number of parallel frame-based carriers (such as Dolby E) alongside, and often within, the video. Namely:

- Each Dolby E stream, within an AES-3 / SMPTE-337 data pair, must be synchronous and aligned with the video to allow a video stream to be switched or recorded cleanly. Incorrect alignment can lead to muting, or even high amplitude noise bursts.

As with SMPTE RP-168 switching, there is a small alignment tolerance. Upstream switched, or externally provided sources can present problematic deviations from the preferred Dolby E frame position.

- Each video standard has its own specified Dolby E frame alignment point. Thus, a standards-agile broadcast environment must arrange for correct referencing and delay adjustment in each standard.
- The embedding of audio within the video stream adds considerable timing uncertainty, and increases susceptibility to external factors such as loading of ancillary space and audio sample distribution produced by equipment in the video chain. In particular, standard definition is more prone to these issues than high definition.

The IQSYN21 is well equipped to deal with issues of carrying Dolby E audio within a broadcast environment. It has the tools required for the correct and easy handling of Dolby E in the following features:

- Transport enablers such as SMPTE-337 aware routing and channel status passing.
- Monitoring and logging of Dolby E frame timing for both passed and newly-embedded audio.
- Manual alignment facilities for consistently arranged environments.
- Automatic realignment of Dolby E frames to preferred or non-standard positions.

## Appendix E. Dolby E

### E.1 What is Dolby E?

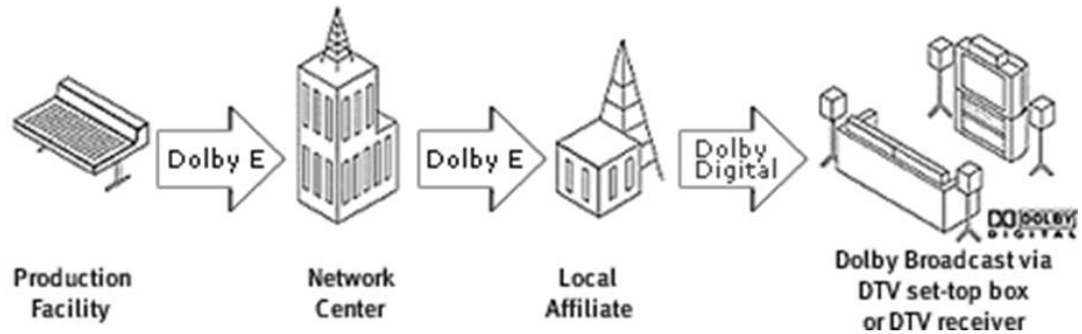

Dolby E is a digital audio technology optimized for the distribution of surround and multichannel audio through digital two-channel postproduction and broadcasting infrastructures.

The Dolby E signal does not reach viewers at home. It is decoded back to baseband audio just prior to the final DTV transmission and then re-encoded into the final audio format specified by the various DTV emission systems (for example, Dolby Digital in ATSC, DVB, satellite, and cable systems; and AAC for ISDB in Japan).

With Dolby E, up to eight channels of audio, plus consumer and professional metadata, can be distributed via any stereo (AES/EBU) channel or recorded onto two audio tracks of conventional digital video tapes, video servers, communication links, switchers, and routers. Because the frame rate of Dolby E matches that of the video it accompanies, programs can be effortlessly switched, edited, and successfully encoded and decoded many times throughout the various stages of the broadcast chain. Audio/video synchronization is also simplified, with exactly one frame of delay added per Dolby E encode or decode stage.

### E.2 Dolby E and Metadata

Metadata allows content providers unprecedented control over how a program will be reproduced in the home. Dolby E conveniently transports both consumer and professional metadata created during program production. Consumer parameters (transferred as a serial data stream from Dolby E to Dolby Digital codecs during the final audio encode, just prior to multiplexing with the digital video for final DTV transmission) are carried in both the Dolby E and the Dolby Digital bitstreams, while professional parameters are carried only in Dolby E and never reach viewers. All metadata parameters can pass unchanged through the various broadcast distribution stages.

### E.3 Dolby E Partner Program

The Dolby E Partner Program provides broadcasters and systems designers with information about Dolby E compatibility of professional broadcast products. This information will help you plan your product purchase and system design decisions to create a clear path in your facility for the benefits and advantages of Dolby E technology.

### E.4 16- and 20-bit Dolby E

Any signal path that can carry a 16- or 20-bit audio signal, SMPTE 302M compatible, can carry Dolby E.

If the supported word length is 16 bits, the two channels together will offer a bandwidth of 1.536 Mbps, which Dolby E can use to carry six discrete audio channels plus metadata (descriptive and playback-control data related to the audio).

If 20-bit word length is available, the two channels will yield a combined bit rate of 1.92 kbps, which Dolby E uses to carry up to eight channels (perhaps a 6-channel surround mix plus a separate stereo mix), as well as metadata. A 24-bit mode is also specified for the Dolby E format but not yet implemented in encoders and decoders.

### E.5 Dolby Digital and AC3

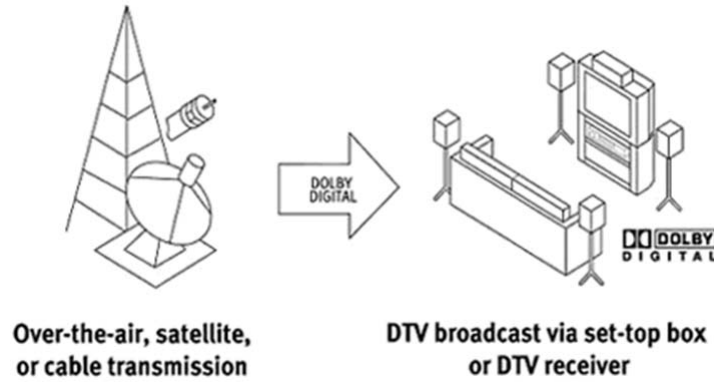

Also known as AC-3, Dolby Digital delivers up to 5.1 discrete channels of surround sound and is applied to the final broadcast transmission signal, just prior to multiplexing with the digital video. It is used extensively today on digital satellite (DBS), cable, and DTV and HDTV terrestrial services (including ATSC and DVB).

The flexibility of Dolby Digital enables broadcasters to deliver any number of audio channels, from all encompassing 5.1 surround sound down to mono audio, plus multiple-language programs and other specialized services. In the home, the Dolby Digital signal adapts to the viewer's playback system, delivering the best possible sound to all viewers, regardless of their equipment.

To enjoy the full 5.1 surround experience, viewers simply connect any DTV set-top box with a Dolby Digital output to a Dolby Digital home theater receiver.

### E.6 Metadata

The key to the adaptability of Dolby Digital is metadata, "data about the audio data." Metadata is created during the production of DTV programming and is carried in the Dolby Digital bitstream. Metadata parameters maintain the "vision" of the audio created by a program's producer, make life easier for broadcasters, and give viewers the best audio DTV has to offer, whether viewers own mono, stereo, or 5.1-channel audio system

© 2005 Dolby Laboratories, Inc. All rights reserved