

V1635

24-bit Audio Variable & Tracking Delay Module

Includes: V1635AA, V1635DD, V1635DA, V1635AD

User Guide

Issue: 7.0



Vistek V1635 24-bit Audio Variable & Tracking Delay Module

Contents

1	Description	3
2	Installation	5
2.1	Rear Panel Connections	5
2.2	Output Wordlength Setting	8
2.3	Video Reference Input Impedance	8
2.4	AES Reference Input Impedance	8
2.5	MIL/MOL Adjustment	8
3	Operation	10
3.1	Front Panel Controls and Indicators	10
3.1.1	Remote Control Access and Power Indicators	10
3.1.2	Sampling Rate Indicators	10
3.1.3	Reference Indicators	10
3.1.4	Character Display	11
3.1.5	Parameter Selection Controls	11
3.2	Adjustment of Operating Parameters	11
3.2.1	General	11
3.2.2	Delay Adjustment	12
3.2.3	Reference Setting	13
3.2.4	Sample Rate Select	13
3.2.5	A/B Swap	13
3.2.6	Test Tone	14
3.2.7	Input Gain	14
4	Dart Interface	15
4.1	General	15

Vistek V1635 24-bit Audio Variable & Tracking Delay Module



1 Description

The V1635 is a broadcast quality 24-bit audio variable and tracking delay unit which forms part of the Vistek V1600 range of interface products. It is a 3U high card which is fitted into either a V1601 or V1603 rack, from which it receives its power. A passive rear module with screw terminal connections, is required for all signal interconnections.

Depending on the build option chosen, input to the unit is either two stereo pairs of analog audio inputs or two AES digital audio streams. Output from the unit is either two stereo pairs of analog outputs or two AES digital audio streams. The V1635 is fully compatible with the Vistek DART remote system, allowing status information to be read and control settings invoked by a DART compatible rack controller.

INPUTS

AES OPTION

- 2 x AES3-1992 balanced 110Ω digital audio channels, $Z_{out} = 110\Omega$ (or AES3id 75Ω unbalanced with special rear module). Sample rates of 32-96kHz are supported.
- The two AES inputs need not be the same sampling frequency as each other, or the output, since the unit performs asynchronous sampling rate conversion.

ANALOG OPTION

- 4 x Analog differential quasi-balanced outputs with $Z_{in} > 20k\Omega$
- Max input level: $+28dBu = 0dBFS$. Input sensitivity adjustable by on-card switches from $+14dBu = 0dBFS$ to $+28dBu = 0dBFS$ in 1dB steps.

OUTPUTS

AES OPTION

- 2 x AES3-1992 balanced 110Ω digital audio channels, $Z_{out} = 110\Omega$ (or AES3id 75Ω unbalanced with special rear module).
- Sampling frequencies of 32kHz, 44.1kHz, 48kHz.
- AES outputs A and B can reference-locked to an NTSC/PAL video source, a separate AES reference source, or can be free-running to the internal crystal oscillator.
- AES channel status output to AES3-1992. Channel status present on the input is passed to the output, amended appropriately for the setting in use.

ANALOG OPTION

- 4 x Analog differential quasi-balanced outputs with $Z_{out} < 50\Omega$
- Max Output level: $0dBFS = +28dBu$. Output level adjustable by on-card switches from $0dBFS = +14dBu$ to $0dBFS = +28dBu$ in 1dB steps.



Vistek V1635 24-bit Audio Variable & Tracking Delay Module

FUNCTIONS

- Panel Selectable/DART controlled **Delay** from 0ms to 1250ms may be applied to the outputs. All outputs are subject to the same delay value.
- Panel Selectable/DART controlled **A/B Swap** transposes the AES input streams.
- Panel Selectable/DART controlled **Test Tone** of 997Hz at -18dBFS may be applied to either or both A or B channelpair analog outputs
- Panel Selectable **Reference Source** can be external Video at 48kHz, external AES reference at 32kHz or 48kHz, or internal free-running crystal oscillator at any sample rate. Either of the AES input channels can also be used as an AES reference source at 32kHz or 48kHz.
- Panel Selectable **Sample rate** can be 32kHz, 44.1kHz, or 48kHz.
- Control source may be Panel switches (LOCAL mode) or DART (REMOTE mode)
- Minimum throughput delay (MTD) is typically 1.5ms.
- **Tracking delay** from MTD+0 to MTD+84ms is provided. Tracking input is a TTL level pulse width modulated (PWM) input pulsetrain with repetition rate equal to PAL/NTSC frame rate. Tracking pulse widths from 4 μ s to 165ms are recognised.
- Tracking delay resolution is one sample period (22 μ s at 48kHz sampling rate)
- Delay tracking employs a polyphase filtering DSP algorithm that ensures low noise and distortion during delay tracking (typically -60dB) and the constrained rate of delay change ensures very small pitch change, typically 0.15%
- Panel Selectable/DART controlled **Input Gain** in the range -16.00dB. . .+15.75dB in 0.25dB steps may be applied to each input channel.

Vistek V1635 24-bit Audio Variable & Tracking Delay Module



2 Installation

2.1 Rear Panel Connections

The standard 3U Screw terminal rear panel is shown below. Other 3U and 1U panel variants with screw terminal and/or BNC connectors are similarly marked. Table 2.1 describes the connections to the unit when these panels are used.

Notes on Table 2.1:

1. Table entries in *italic text* denote the connections to be made when the input or output audio is *analog*.
2. Table entries in **regular** text denote connections to be made when input or output audio is **AES digital**.
3. When input or output audio is digital, certain connections are **reserved**. Do not connect anything to these connections.
4. Grounds/screens (S) are connected to chassis on all outputs and inputs and should be connected to all cable screens to minimize hum and noise.
5. On units with analog output option, neither (+ or -) output should be grounded.
6. The TRACK input accepts a pulsetrain of active high TTL-level pulses at either NTSC or PAL frame rate (33/40ms). The pulses should be are PWM modulated in direct 1:1 proportion to the required delay. In other words the pulse width (high) in milliseconds, equals the required delay. Pulse widths shorter than 1 μ s or longer than 40ms are ignored by the V1635.

Table 2.2 describes connections to the unit when D-type panels are used. The V1635 is designed to use a common rear panel for all variants of the module.



Vistek V1635 24-bit Audio Variable & Tracking Delay Module

Notes on Table 2.2:

1. No connect means do not connect this pin to anything.
2. For modules equipped with AES outputs, both pairs of outputs are available on D-type rear panels. These are denoted as AESA1, AESA2 etc.

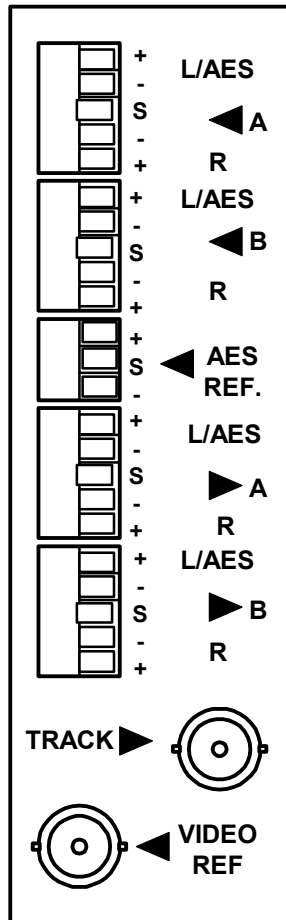

Vistek V1635 24-bit Audio Variable & Tracking Delay Module



Table 2.1

Description of V1635 rear panel connections for standard rear panel assemblies

SIGNAL name	SOURCE	COMMENTS
POWER DART bus	Rack PWR Header Rack DART header	+15V nominal (9-35V) at 10W max Vistek DART Rack controller
A 3 (IN) L/AES (+/-)	External AES source	AES3/AES3id digital input for channelpair A
	<i>Ext. Analog source</i>	<i>L Analog input for channelpair A</i>
R (+/-)	Do Not Connect	Reserved
	<i>Ext Analog source</i>	<i>R Analog input for channelpair A</i>
B 3 (IN) L/AES (+/-)	External AES source	AES3/AES3id digital input for channelpair B
	<i>External Analog source</i>	<i>L Analog input for channelpair B</i>
R (+/-)	Do Not Connect	Reserved
	<i>External Analog source</i>	<i>R Analog input for channelpair B</i>
A 4 (OUT) L/AES (+/-)	V1635	AES3/AES3id digital output for channelpair A
	V1635	<i>L Analog output for channelpair A</i>
R (+/-)	Do not Connect	Reserved
	V1635	<i>R Analog output for channelpair A</i>
B 4 (OUT) L/AES (+/-)	V1635	AES3/AES3id digital output for channelpair B
	V1635	<i>L Analog output for channelpair B</i>
R (+/-)	Do not connect	Reserved
	V1635	<i>R Analog output for channelpair B</i>
AES 3 (IN) REF	External AES reference reference source	AES3/AES3id digital input for reference
VIDEO 3 (IN) REF	External video reference source	525/625 line analog studio grade reference 75Ω/Hi-Z
TRACK 3 (IN)	External video synchroniser	TTL-level PWM pulsetrain at PAL/NTSC frame rate. Pulse width = delay



Vistek V1635 24-bit Audio Variable & Tracking Delay Module

Table 2.2

Description of V1635 rear panel connections for D-type rear panel assemblies

D15F Input connector					
Pin	Analog	AES	Pin	Analog	AES
1	A left in -	AES A in -			
2	A right in -	No connect	9	A left in +	AES A in +
3	GND	GND	10	A right in +	No connect
4	AES Ref in -	AES Ref in -	11	GND	GND
5	B left in -	AES B in -	12	AES Ref in +	AES Ref in +
6	B right in -	No connect	13	B left in +	AES B in +
7	GND	GND	14	B right in +	No connect
8	GND	GND	15	GND	GND

D15F Output connector					
Pin	Analog	AES	Pin	Analog	AES
1	A left out -	AES A1 out -			
2	A right out -	No connect	9	A left out +	AES A1 out +
3	GND	AES A2 out -	10	A right out +	No connect
4	GND	No connect	11	GND	AES A2 out +
5	B left out -	AES B1 out -	12	GND	GND
6	B right out -	No connect	13	B left out +	AES B1 out +
7	GND	AES B2 out -	14	B right out +	No connect
8	GND	GND	15	GND	AES B2 out +

2.2 Output Wordlength Setting

The digital audio output wordlength is normally 24 bits. It may be set to **20 bits** by closing jumper LK1.

2.3 Video Reference Input Impedance

The video reference input impedance is 75Ω when jumper LK3 is **closed**. It is high impedance when jumper LK3 is open to facilitate video reference daisy chaining.

2.4 AES Reference Input Impedance

The AES reference input impedance is **110/75 Ω** when jumper LK4 is **closed**. It is high impedance when LK4 is open, facilitating reference daisy chaining. Daisy chains may be up to 4 modules in length.

2.5 MIL/MOL Adjustment

On V1635 options with analog inputs two rotary Hex Switches are provided for adjusting the **MIL** (**M**aximum **I**nput **L**evel) of the analog inputs for each channel pair A and B. **MIL** is adjustable in 1dB steps from +14dBu to +28dBu. (A special order variant with **MIL** adjustable from +4dBu to +18dBu is also available)

Vistek V1635 24-bit Audio Variable & Tracking Delay Module



On V1635 options with analog outputs, two rotary Hex Switches are provided for adjusting the **MOL** (**M**aximum **O**utput **L**evel) of the analog outputs for each of the channelpairs A and B. **MOL** is adjustable in 1dB steps from +14dBu to +28dBu. (A special order variant with **MOL** adjustable from +4dBu to +18dBu is also available)

MIL/MOL setting versus switch position for both analog inputs and outputs is shown in the table below.

Switch setting	MIL/MOL for 0dBFS
0	+14
1	+15
2	+16
3	+17
4	+18
5	+19
6	+20
7	+21
8	+22
9	+23
A	+24
B	+25
C	+26
D	+27
E	+28
F	reserved

The figure below shows location of all jumpers and switches that may be fitted across the range of V1635 variants.

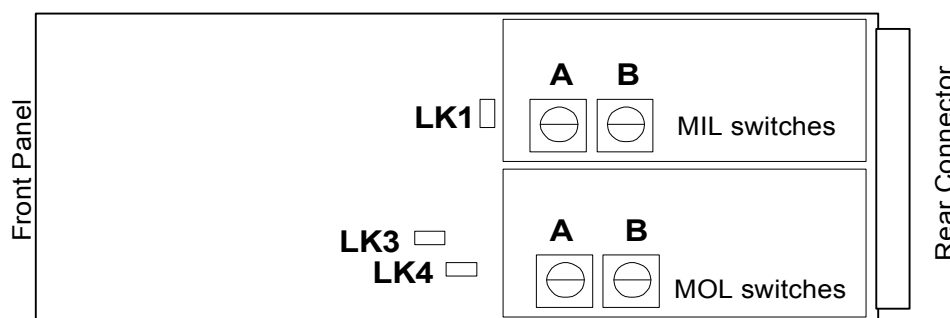



Vistek V1635 24-bit Audio Variable & Tracking Delay Module

3 Operation

3.1 Front Panel Controls and Indicators

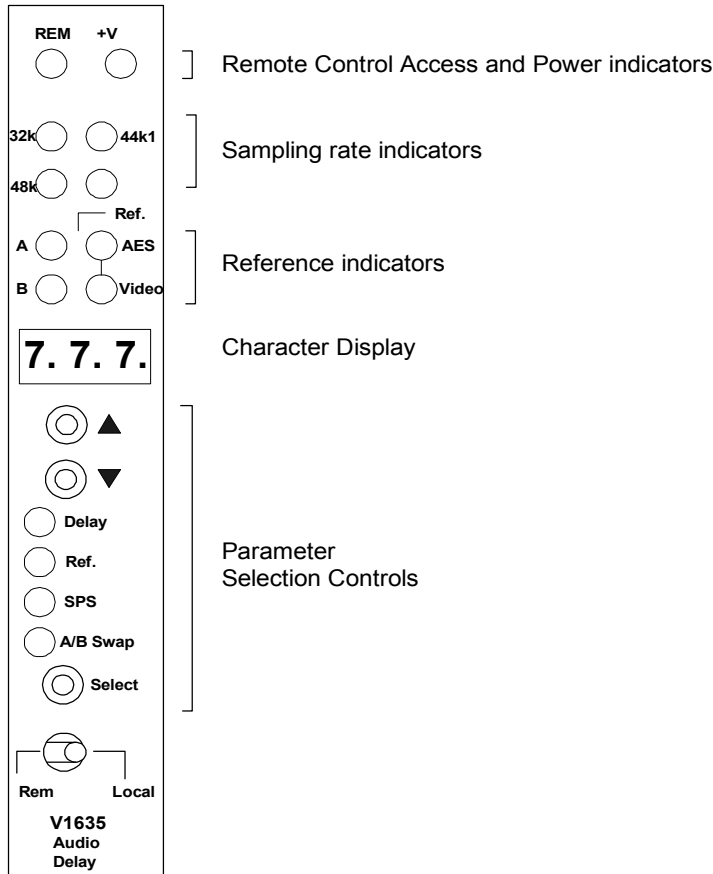

3.1.1 Remote Control Access and Power Indicators

The green V+ LED is lit when the unit's on-board power supply is delivering voltage. The yellow REM LED is lit whenever the unit is accessed by the Rack Controller for the DART remote system.

3.1.2 Sampling Rate Indicators

These LEDs indicate the sampling rate of the AES digital outputs, as selected by the Parameter Selection Controls. On variants with analog outputs the LEDs show the internal sampling rate.

3.1.3 Reference Indicators

These LEDs indicate the present reference source, as selected by the Parameter Selection Controls. When Free-Running (internal crystal oscillator) is selected, none of the LEDs are lit, and when an external AES or Video reference is selected and is present, the appropriate LED will be lit continuously. If the selected external AES or Video reference fails, the LED will flash and the V1635 will default to free-running mode until the reference recovers.

Vistek V1635 24-bit Audio Variable & Tracking Delay Module



3.1.4 Character Display

Used for displaying parameters which have numeric or alphanumeric values. During parameter selection the display indicates the present value of the parameter and during normal operation the display shows the present value of the total delay, i.e. the sum of the preset adjustable delay and the tracking delay value.

3.1.5 Parameter Selection Controls

These are used for selection of, and adjustment of, operating parameters when the REM/LOCAL switch is set to LOCAL.

3.2 Adjustment of Operating Parameters

3.2.1 General

The V1635 has a three *pages* (**Page 0**, **Page 1** and **Page 2**) of panel adjustment modes, each page allows adjustment of one or more *parameters*. Conceptually the procedure is not unlike setting a digital alarm clock or watch.

- Panel adjustment pages can only be invoked if the **REM/LOCAL** switch on the panel is set to **LOCAL**.
- Pressing the **SELECT** button on its own invokes the panel adjustment modes of **Page 0**
- Pressing the **SELECT** button while holding in the **p** button invokes the panel adjustment modes of **Page 1**. The **p** button is analogous to a 'SHIFT' key on a computer keyboard when selecting pages of adjustment modes.
- Pressing the **SELECT** button while holding in the **q** button invokes the panel adjustment modes of **Page 2**. The **q** button is analogous to an 'ALT' key on a keyboard when selecting pages of adjustment modes.
- Once any panel adjustment page has been selected, repeated pressing of the **SELECT** button allows the user to scroll through the various parameters available on the page. A row of LEDs above the **SELECT** button indicates which *parameter* is presently selected for adjustment.
- For any given parameter selected for adjustment, the value of the parameter may be increased or decreased by pressing the **p** or **q** keys respectively. The *value* of the parameter is indicated either on the character display or the respective sets of LEDs above the character display.
- Holding the **p** or **q** buttons down will cause the value of the parameter to auto increment and autodecrement respectively. The longer the button is held down, the faster the rate of autoincrement or autodecrement.
- Once a parameter has been adjusted to the desired value, the Panel Adjustment mode is exited by pressing the **SELECT** button until all four of the LEDs above the **SELECT** button are off.



Vistek V1635 24-bit Audio Variable & Tracking Delay Module

- The V1635 has non volatile memory storage that automatically saves the values of all the operating parameters set in LOCAL mode so that on power-up or when the REM/LOCAL switch is switched from REM to LOCAL, the last settings made in LOCAL mode will be restored. Parameter adjustments take effect immediately but are only saved to non-volatile memory on the V1635 when the adjustment mode is exited.

The following table indicates the available Panel Adjustment modes on the two pages.

LED indicator	Page 0		Page 1		Page 2	
	Parameter	Adjust range	Parameter	Adjust range	Parameter	Adjust range
Delay	Delay	0ms to 2500ms	Test Tone	A,B Off/A,B on	Input Gain A1	-16.00dB..+15.75dB
Ref.	Reference	A,B, Free, AES, Video	-		Input Gain A2	-16.00dB..+15.75dB
SPS	Sample rate	32, 44.1, 48kHz	-		Input Gain B1	-16.00dB..+15.75dB
A/B Swap	Input select	A, B	-		Input Gain B2	-16.00dB..+15.75dB

3.2.2 Delay Adjustment

(i) A fixed delay may be applied to all four analog channels as a group and the present setting may be seen on the character display as a number when **Page 0** Panel Adjustment mode has been entered and **Delay** selected as a parameter.

- By Panel Selection the delay value may be adjusted from 0ms to 1.25 seconds. Adjustment from 0 to 99ms is in 1ms steps, and adjustment from 100ms upwards is in 10ms steps. From 0 to 999ms, the delay value is displayed in ms and from 1.0s upwards it is displayed in seconds.
- The DART interface can control the delay in 1ms steps across the range.

Note: changing the adjustable delay will cause a temporary disruption of audio for a time not less than the difference between old and new delay settings.

(ii) Operation of the tracking delay is transparent to the user and no adjustment is provided.

In LOCAL mode the unit will track delay if input pulses are found at the TRACK socket. If the tracking pulsetrain is absent or invalid, the V1635 will set the tracking delay to zero. On power-up the tracking delay is set to zero so that if no tracking pulsetrain is input, no additional delay will result. During normal operation the display shows the present value of the total delay, i.e. the sum of the preset fixed delay and the tracking delay value.

In REMOTE mode, the tracking delay may be disabled if desired, and the tracking delay value is readable as a separate parameter.

(iii) The V1635 has a minimum throughput delay of typically 1.5ms.

Vistek V1635 24-bit Audio Variable & Tracking Delay Module



3.2.3 Reference Setting

The reference source may be selected and the present setting may be seen on the Ref LEDs when **Page 0** Panel Adjustment mode has been entered and **Ref.** selected as a parameter. The selectable options will depend on the V1635 variant as follows:

- On cards with analog outputs and analog inputs, only **Free Run** reference may be selected (all Ref LEDs off.)
- On cards with analog outputs and digital inputs, only **AES A** reference may be selected.
- On cards with digital outputs and analog inputs, the reference may be set to **Free Run**, **AES REF** or **Video** which correspond to Ref LEDs none, AES and Video being lit respectively. On cards with digital outputs and digital inputs, either of the two AES input channelpairs **AES A** or **AES B** may also be used as reference and the options become **A**, **B**, **Free Run**, **AES**, or **Video**
- In all cases, if an external reference fails, the appropriate LED will flash and the V1635 will default to **Free Run** mode with reference from the internal crystal oscillator.

Not all references are supported at all sample rates. Please note the following:

- **AES A**, **AESB** or **AES REF** reference is only available at 32kHz or 48kHz.
- **Video** Reference is only available at 48kHz.
- **Free Run** reference is available at all sample rates.

3.2.4 Sample Rate Select

The sample rate of the V1635 may be selected and the present setting may be seen on the SPS LEDs when **Page 0** Panel Adjustment mode has been entered and **SPS** selected as a parameter. The selectable options will depend on the V1635 variant as follows:

- On cards with analog outputs, the SPS refers to the internal sample rate and is fixed at **48kHz**.
- On cards with digital outputs, the SPS refers to the internal and output sample rate and may be set to **32kHz**, **44.1kHz** or **48kHz**.

3.2.5 A/B Swap

A transposition of AES A and AES B inputs may be invoked and the present setting may be seen on the character display as a letter combination when **Page 0** Panel Adjustment mode has been entered and **A/B Swap** selected as a parameter.

- When input channelpairs A and B are routed to output channelpairs A and B respectively, the A/B Swap parameter is **Normal** and is indicated on the character display as **A-A**.
- When input channelpairs A and B are transposed to output channelpairs B and A respectively, the A/B Swap parameter is **Swapped** and is indicated on the character display as **A-b**.



Vistek V1635 24-bit Audio Variable & Tracking Delay Module

3.2.6 Test Tone

A test tone of 997Hz may be invoked on both channels of either or both A and B channelpairs and the present setting may be seen on the character display as a number combination when **Page 1** Panel Adjustment mode has been entered and **Test Tone** selected as a parameter. The table below explains the available Test Tone selections

Display	Test Tones
0 0	No test tones selected
1 0	Test tone on channelpair A only
0 1	Test tone on channelpair B only
1 1	Test tone on both channelpairs

The test tone is the same frequency (± 1 Hz) for all available sample rates, but the output amplitude depends on the V1635 variant as follows:

- On cards with digital outputs, the test tone is -18dBFS.
- On cards with analog outputs the test tone is 0dBu.

3.2.7 Input Gain

Gain on each of the four inputs A1, A2, B1, B2 may be varied in the range -16.00dB to $+15.75\text{dB}$ in steps of 0.25dB . The gains are applied in the signal chain before the A-B switch and are invoked 'on the fly'. The module is shipped with 0dB gains set on all inputs. The present setting of gain may be seen on the character display as a deciBel number when **Page 2** Panel Adjustment mode has been entered and **Input Gain A1** through **Input Gain B2** selected as a parameter. A trailing decimal point after the third display digit is used to indicate a fractional gain value is invoked. When setting the Input Gains, the user should count the switchpresses between integers in order to establish the fractional value. In REMOTE mode, control software can be tailored to apply 'ganged pot' gains if desired.

Vistek V1635 24-bit Audio Variable & Tracking Delay Module



4 Dart Interface

4.1 General

The V1635 is a Class 4 DART module with a serial EEPROM for reading and writing card details through the DARTbus in the same manner as other V1600 range cards. In addition the unit has several read and write registers, details of which may be found in document ***scsm1635.doc***. Settings of operating parameters made via the DART interface are not stored in non-volatile memory by the V1635, and NV memory in the remote control system is used for storing these settings.