



V1643

FRAME SYNCHRONISER

INSTALLATION and OPERATION

© Vistek Electronics Ltd

Filename: v1643om_10.doc
Issue : 02
Date: April 2004

CONTENTS

1. DESCRIPTION	5
2. INSTALLATION	6
2.1 REAR PANELS	6
2.2 CONNECTIONS	6
2.3 SIGNAL SPECIFICATIONS	7
2.4 GPI CONNECTION	7
2.5 VIDEO INSERTION DELAY	7
2.6 ADJUSTMENT RANGES	8
2.6.1 Video Adjustments	8
2.7 HARDWARE	8
2.7.1 The PCB	8
2.7.2 Links and Switches	8
2.7.3 Fuse	8
2.8 FRONT PANEL	10
2.8.1 Direct Indications	10
2.8.2 Display and Switches	11
2.8.3 Remote/Local Control	11
3. BLOCK DIAGRAMS	12
3.1 VIDEO PROCESSING	12
4. SYSTEM OPERATION	13
4.1 LOCAL CONTROL	13
4.1.1 Start up	13
4.1.2 Menu Control	13
4.1.3 Menu Examples	14
4.1.4 Sleep	14
4.1.5 Banner	15
4.1.6 High Level Signal Status	15
4.1.7 Variable Calibration	15
4.2 REMOTE CONTROL	16
4.3 FRAME SYNCHRONISER	17
4.3.1 SDI Inputs	17
4.3.2 SDI Buffer Output	17
4.3.3 SDI Main Output	17
4.3.4 Video Reference	17
4.3.5 SDI Input Fail	18
4.3.6 Video Reference Fail	18
4.3.7 Standard Detection	18
4.3.8 Manual Freeze	19
4.3.9 Vertical Interval	19
4.3.10 Special Vertical Blanking (525 Mode only)	20
4.3.11 Minimum Delay	20
4.3.12 Delay Signal	20
4.3.13 Ancillary Data	22
4.3.14 TRS Signals	22
4.3.15 Test Patterns	22
4.3.16 EDH	23
4.4 SYSTEM	23
4.4.1 GPIs	23
4.4.2 VCO Centre Frequency	23
4.4.3 Version Numbers	24
4.4.4 Test Patterns	24
4.4.5 Cross Standards	24
4.4.6 Illegal Codes	24
4.4.7 525 V-BIT of TRS	24
4.4.8 Display Sleep	25
4.4.9 Display Brightness	25
5. CALIBRATION	26
5.1 SET-UP	26
5.2 FREE-RUN FREQUENCY	26
6. TROUBLE SHOOTING GUIDE (FAQS)	27
6.1 VIDEO	27

6.2 OTHERS 27

CONTENTS (Cont'd)

7. FRONT PANEL MENUS 28
7.1 V1643..... 28

8. CONTROLS..... 29
8.1 Frame Synchroniser - FRM SYNC..... 29
8.2 Operating Conditions – STATUS..... 30
8.3 Engineering – ENG’ ING..... 30
8.4 Calibration – CALIB..... 31
8.5 Configuration – CONFIG..... 31
8.6 Test Mode – TEST 31

9. SOFTWARE VERSIONS..... 32

1. **DESCRIPTION**

The V1643 is an SDI Video Frame Synchroniser which forms part of the Vistek V1600 range of interface products. It is a 3U high card which is fitted into either a V1601 or V1606 rack (or even the earlier generation V1603) from which it obtains its power and control. A passive rear module is required for all signal interconnections. A range of these are available for both the V1601 and V1606/V1603 chassis.

The frame synchroniser operates in both 625/50 and 525/60 formats and the SDI input will automatically detect which format, if any, is present. An external analogue video reference, usually Black and Burst, is normally applied and this may also be either format (PAL or NTSC). The timing of the SDI output may be varied relative to the reference both horizontally over a whole line and vertically over ± 127 lines.

On the standard rear panels for the V1643 one of the SDI ports can be set to be either a second SDI input, a buffered loop-through of the main input or an extra synchronised output. The reference input has two BNCs for a passive loop-through. A termination can be selected using a link on the main board. A TTL signal representing the delay through the video path is also available on a BNC.

There is no audio processing on this unit, but it is possible to blank or pass the horizontal blanking interval of the SDI signal which may contain audio (or other ancillary) data.

The V1643 is fully dual standard for both 625/50 and 525/60 D1 signals and automatically detects the presence and format of the input signal and operates accordingly. It also monitors the video reference, to detect its presence and format. If the input and reference are of opposite formats then the operator can choose how the unit works – either always produce a valid output on the reference format or ignore the reference and pass the input with a minimum of delay. The input signal is carefully monitored and if it starts to fail, then the unit will freeze the picture until full field data is available again. It can be set to feed black to the output either immediately on input fail or after a suitable time, as set by the operator.

The unit contains a simple test pattern generator which provides a selection of full D1 specification test signals.

There is a versatile front panel with an alphanumeric display which lets the operator set up a large number of parameters and read the internal status of the unit. Also it is fully compatible with the DART remote control system which means it can be controlled by either of the Vistek control panels, V1602 or V1605, or either of the software based systems, a Viewfind PC, or the ViewNet server based control system. Additionally third party control systems can access the unit through the DART system.

There are three GPI inputs which the user can configure for a variety of functions, such as Test Patterns, Freeze etc.

On later versions (V1.1.0 and later) the Delay output can also be used as a General Purpose Output. In this case instead of Delay it can indicate Input Fail, Input 2 Selected, Power Good or Reference Fail.

2. INSTALLATION

2.1 REAR PANELS

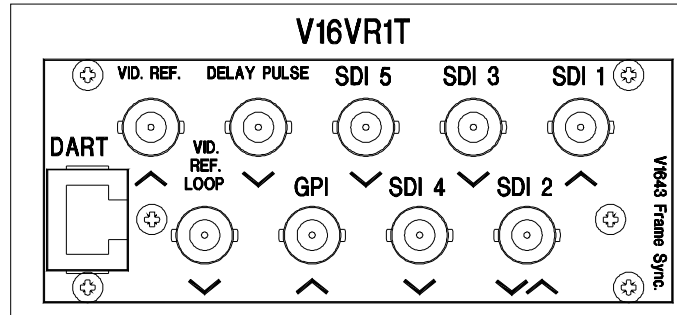
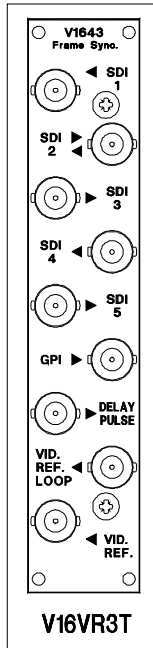

2.2 CONNECTIONS

On all the rear panel types the upper three BNCs are for SDI video as follows:

Connector	Type	Function
SDI 1	BNC	SDI Video I/P
SDI 2	BNC	SDI I/P 2 or O/P 2 or SDI Buffer (see Note)
SDI 3	BNC	SDI O/P
SDI 4	BNC	SDI O/P
SDI 5	BNC	SDI O/P
GPI	BNC	GPI Input..
DELAY	BNC	Delay Pulse O/P.
REF LOOP	BNC	Reference Loop
REF	BNC	Reference Input. Link selectable termination on board.
DART	RJ45	DARTNET access. Valid in slot 1of 1U Rear only

Note: The three options for SDI 2 are by a pair of links on the main PCB (LKs 2 and 3). It is important that both links are set up the same way.

2.3 SIGNAL SPECIFICATIONS

SIGNAL	TYPE	COMMENTS
Power (No Module)	9.8W	Supplied from rack
SDI Inputs and Outputs	BNC	SDI Video to SMPTE 259M Max cable length >200m
Video Reference	B+B	Any 1V Composite video may be used, but Black & Burst is recommended.
DELAY 75	TTL, 75R	Positive pulse represents the video insertion delay. Repeat period is 2 frames (80ms for 625/50 and 67ms for 525/60).
GPI	5V pull-up via 4K7	Connect to GND to activate.

2.4 GPI CONNECTION

There is only one GPI input to the V1643. It is connected through a BNC connector on the rear panel. It has an internal pull-up resistor of 4K7 to +5V and should be made active by grounding the relevant pin.

The status of the GPI pin can be monitored on:

```
STATUS      GPI Sta  1
```

The arrows indicate the status of the GPI input by pointing up if the GPI is active (in practice this means that they point down for +5V and up for 0V).

The use of the GPI is described in Section 4.4.1.

2.5 VIDEO INSERTION DELAY

The V1643 is primarily a synchroniser so the insertion delay is inherently variable over the range of a frame (40ms for 625/50 and 33.6ms for 525/60). In order to be able to handle time varying input signal without dropping in and out of a frame of delay there is some hysteresis at the shortest and longest delays. This means that the shortest delay has two values, one for when the input is faster than the reference and one for when it is slower.

There is also a control to set the unit into Minimum Delay (section 4.3.11).

```
FRM Sync  Vid Del  Del Var
           Del Min
```

The unit normally goes into minimum delay mode when the reference is missing, or is of the opposite format to the SDI input. However if the reference is missing the unit can be put into a variable delay mode using menu.

```
FRM Sync  RFL Mode  Min Del
           Var Del
```

This table shows the various delays and where they are measured. Note that the delays are common for both operating standards and do not change whether the Video Processing is enabled or not.

	Delay Pulse ms	Parallel Processing ms	Clocks	SDI to SDI ms
Minimum Minimum	2.75	4.55	122	4.94
Maximum Minimum	12.9	14.75	394	15.12
Set Minimum	3.66	5.5	147	5.88

Thus the delay hysteresis is 10.15µs, equivalent to approximately 270 clock pulses.

2.6 ADJUSTMENT RANGES

2.6.1 Video Adjustments

This table shows the full ranges of the video adjustments:

VARIABLE	RANGE	RESOLUTION
H Timing 625	0 to 63.96µs in 37ns (625)	37ns
H Timing 525	0 to 63.52µs in 37ns (625)	37ns
V Timing	-128 → +127 lines	field lines

2.7 HARDWARE

2.7.1 The PCB

The figure below shows diagrammatically the printed circuit board along with certain other components of interest. In particular it shows the position and orientation of the links and switches which set up the operation modes and the location of the audio sub-module if fitted.

The EPROM location is shown, as it is the component that would need to be changed as a result of any software upgrade in the field. This is a PLCC type and the proper tool should be used to remove a device and care must be taken to ensure that a replacement is inserted the right way round and pushed fully 'home'.

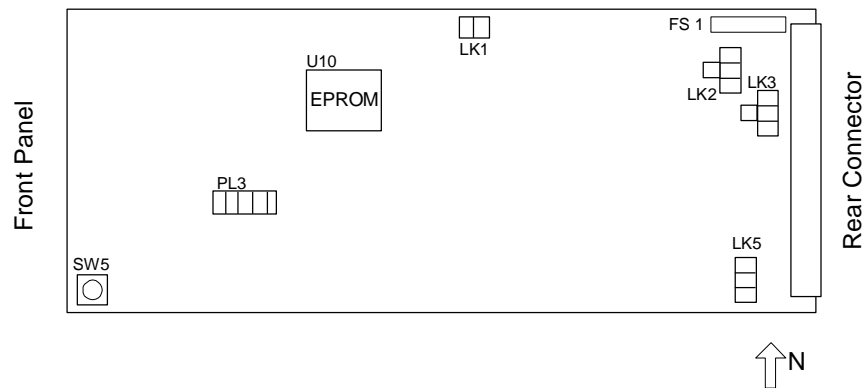

2.7.2 Links and Switches

The purposes of the links and switches is shown in the following table. Details of their operation are described in later sections.

ITEM	Title	Section	Comments
FS 1	Fuse		In series with the +15V input to the module.
SW 5	RESET		Used to reset the internal microcontroller and DSP.
PL 3	JTAG Connector		For development and test use only. (May not be fitted)
LK 1	JTAG enable		Never used in operation. (May not be fitted)
LK 2, 3	Define BNC 2		North – Buffered Output (NOT synchronised) West – SDI Input 2 South – SDI Output 2
LK 5	Video REF Term		North – High Z South – Terminated

2.7.3 Fuse

There is only one fuse on the V1643 which is in series with the main DC input:

FS 1	Fuse 2 Amp Wire ended		In series with the +15V input to the module.
------	-----------------------	--	----------------------------------------------

2.8 FRONT PANEL

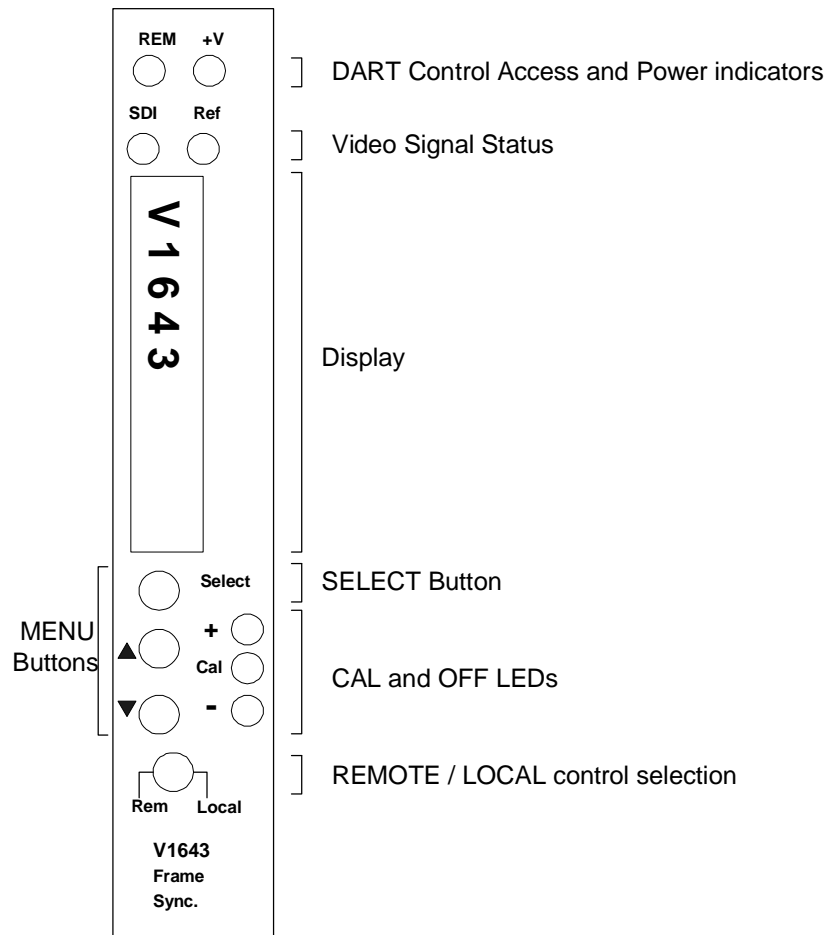

The front panel on the V1643 is a considerable advance on what is usually available on single module interface equipment. It provides the user with total control and monitoring of the unit without the need to consult manuals and read unlabelled indications. While this kind of control is generally available with a remote control system, as it is over DART, it is unusual to have this level of access locally.

At first use the menu system may seem cumbersome but with only a small amount of practice it will become very easy to use.

2.8.1 Direct Indications

The four LEDs at the top of the panel provide these direct indications of the unit:

- | | |
|-----|-----------------------------------------------------------------------------------------------------------------------------------------------------------------------------------------------------------------------------------------------------------------------|
| REM | Short blinks to indicate access by the DART controller, if fitted. It does not directly indicate that the unit is in remote control mode. If the rack frame does not have a Rack Controller fitted then this LED will not blink. |
| +V | Indicates that the main +5V is present on the board. This is derived from the +15V distributed through the rack. The V1643 does have many power rails, but only the main +5V is indicated here. It will, of course, be off if the fuse, FS1, were to have been blown. |
| SDI | Indicates that a D1 signal is being received. |
| REF | Indicates that a video reference signal is being received. |

2.8.2 Display and Switches

The main display is an eight character LED matrix display. It has been set so that when fitted into a 3U rack (V1606) it can be read from the left, and when fitted to a 1U rack (V1601) it is horizontal and the 'proper' way up.

The three buttons are labelled **Select**, **s** and **t**. The **Select** button is used to move down and up the menus. A short press will move down one level, while pressing and holding for about half a second will move up one level. If you continue to hold it will progressively move up a level every half second until it reaches the top level (**SLEEP**), or you let go, in which case it will stay where it is. When at any level the **s** and **t** buttons will move through the list of options, or if in an actual variable (such as Video Gain) they will change the values.

The menu system is described in more detail later in section 4.1.2.

If the unit is in Local control then the display and switches are used to set up and show the operation the module. If in remote mode then they are still active for showing the status but cannot be used to actually change anything.

Beside the **s** and **t** buttons are three LEDs marked **+**, **CAL** and **-**. In general the **CAL** LED is used to show that a variable is set to its normalised value and if not then the others show which direction to which it has been changed or that it is no longer on its CAL value.

2.8.3 Remote/Local Control

The lowest switch selects between Local control and Remote control over DART:

Local	Control is from the front panel itself.
Rem	Control is from the DART system. This requires the use of an external controller running a suitable programme, which communicates with multiple racks using the Dartnet protocol.

3. BLOCK DIAGRAMS

3.1 VIDEO PROCESSING

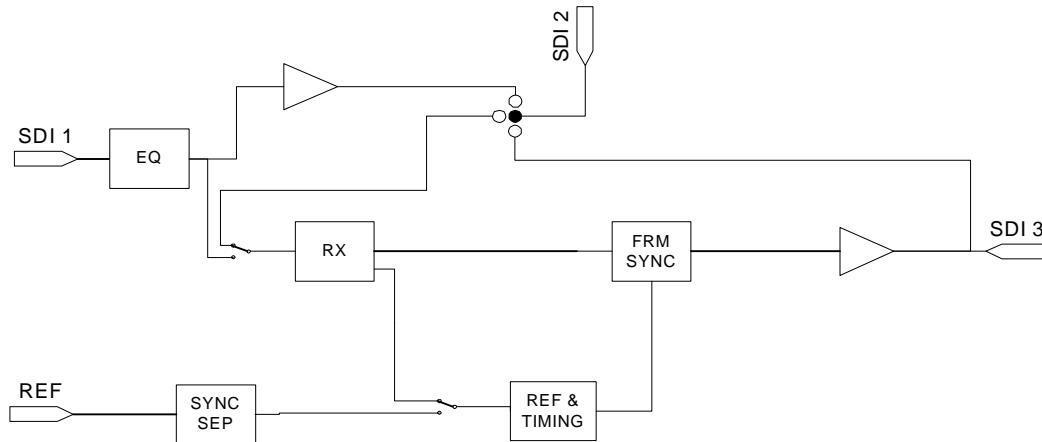

This diagram shows how the video flows through the V1643. In particular the selection for SDI 2 between a second input, a buffered output and a main output can be seen. This drawing is diagrammatic and should not be read literally; for example it may seem that there is no equaliser (EQ) for SDI 2 when it is being used as an input but this is not the case since in fact the EQ is inside the Receiver block (RX) along with the selection switch.

The reference to the Frame Synchroniser can be either from the external reference input or from the input video itself. A third option, not shown here, is that the internal oscillator can free run, but this is only used when there is no input signal and no reference. In fact the selection of the reference between the external and the SDI input is automatic so that the external reference is always used if it is present and the SDI when there is no reference. Similarly if there is a discrepancy between the standard of the SDI and that of the reference then the reference will be ignored and the unit will behave exactly as if the reference were not present. Normally, when locked to the input, the variable timing is disabled and the unit will operate in minimum delay mode; but this can be changed in the **FRM SYNC : RFL Mode** (For Ref. Fail Mode).

FRM SYNC	RFL Mode	Min Del	Minimum Delay mode (default)
		Var Del	Variable Delay Mode

4. SYSTEM OPERATION

4.1 LOCAL CONTROL

4.1.1 Start up

Local control and monitoring of the V1643 is done through the front panel with its eight character LED display and three control buttons **Select**, **s** and **t**. There are three LEDs which also contribute to the status indication; these are labelled **+**, **Cal** and **-**.

After power up the display will start at the top level and show the unit type and any options that are included. These options are not the same as the plug-on modules for the audio I/O. The display will be one of these:

V1643 Standard V1643

4.1.2 Menu Control

The **Select** and **s** and **t** buttons are used to manoeuvre around the menu system. The menu structure has five levels and the **Select** button is used to go up and down the structure. The **s** and **t** buttons are used to move between selections or to adjust a parameter depending on which sort of menu is displayed. The five levels are as follows:

Sleep	Display is blank (except for Banner warnings).
Top Level	As above, e.g. V1643
Main Menu	The Main menu items, such as FRM SYNC , ENG'ING etc. These items are all in Upper Case.
Sub Menu	Menu items under each main heading, such as video or Hor Tim under the FRM SYNC main menu. These items are all in Sentence Case (generally lower case but with upper case first letters).
Parameter	The lowest level under the Sub Menu, and used to actually adjust a parameter. The display will depend on the actual parameter and may be a value such as +0.00dB for a gain or ON or OFF for a switch variable. There is usually a title to describe the variable and a small icon in the left hand character position, but 8 characters cannot provide for a detailed description.

Many of the sub menus depend on which audio I/O sub modules are fitted. For example the Calibration functions of the analogue audio ADCs and DACs under **CALIB** do not appear unless a suitable sub-module is fitted.

To move down a level just press the **Select** button briefly; then press either the **Select** button again to go down another level or the **s** and **t** buttons to move around the options within a level.

To move up a level press and hold the **Select** button for about half a second which will move up one level. If you continue to hold the **Select** button then it will move up a level every half a second until it reaches the Sleep level (one above the Top Level).

A complete list of all the menus is given in Section 7.

4.1.3 Menu Examples

This section has examples of how to manoeuvre through the menu system. The first one starts with the unit in its 'sleep' mode where the display is blank, and then proceeds to set the to pass Ancillary Data.

Action	Display	Comments
Select	V1643	Top Level
Select	FRM SYNC	First Main Menu
▼	STATUS	
▼	ENG' ING	The Main Menu we want
Select	Anc Data	The first Sub Menu in the list
Select	Anc Blnk	The default setting
▼	Anc Pass	Set it as we want it.

Now we shall select how the unit when the input fails. The following steps should be taken from the current position (Select+Hold means that you should press and hold the select button for about half a second):

Action	Display	Comments
Select+Hold	Anc Blnk	UP to the Sub Menu level
Select+Hold	ENG' ING	UP again to the Main Menu
▼	STATUS	
▼	FRM SYNC	Along to the Frame Synch Main Menu
Select	Video	
▼	Hor Tim	
▼	Ver Tim	
▼	Freeze	
▼	VFL Mode	To the Sub Menu we want
Select	3 secs	This is the default mode
▼	4 secs	Select the delay you want. Black = 0 secs

4.1.4 Sleep

If the front panel is not used for a certain amount of time then the display will automatically go into a sleep mode when it will be blank. Pressing any of the buttons will cause it to 'wake up' back into the top level. The time delay before the unit slips into sleep mode can be set up using the **ENG' ING : Sleep** menu.

The brightness of the display can also be adjusted using the **ENG' ING : LEDLevel** menu.

4.1.5 Banner

There are some conditions which need to be directly indicated to the operator and although the display system is highly versatile for a lot of complex operations it is not really convenient for immediate indications. In the past LEDs on the front panel have been used for this purpose.

To help with this a banner message will pass across the screen from right to left to show any critical statuses when the display is in sleep mode. This saves the need to manoeuvre down the menus to find out, for example, that a Test Pattern has been selected. Remember it is not necessary to wait for the time-out period for the unit to go into sleep mode, it can be forced there by going up a level from the so-called Top Level. The following conditions will be displayed on the Banner:

Minimum Delay	(by command only, not by cross standards)
Video Frozen	(by command only, not i/p fail)
Test Pattern	
Fade to Black	
Free-run	
System in Test Mode	(Not available to user)

4.1.6 High Level Signal Status

There are two LEDs on the top of the front panel to indicate that the SDI and video reference inputs are present, and consequently these also indicate that they are absent. However there is no direct indication as to the format of these signals, i.e. 625/50 or 525/60. Since many installations may use multiple formats and therefore need a quick indication there are parallel menus with the Top Level.

If you press the *s* and *t* buttons from the Top Level then you will see the SDI and Video Reference status directly. In each case this will show the signal presence and if it is there then what format it is. Again this is considerably faster than manoeuvring down the menu structure. For example:

SDI 6254

There are in fact four different stati available at this level. They are:

IP 625 4	or	IP FAIL
RF 625 4		NO REF
DEL >1FD		DEL <1FD

These indications are still at the Top Level, so a single press of the Select button will immediately move down the menu tree.

4.1.7 Variable Calibration

Most variables have a calibrated or normalised value. In some cases this is obvious, such as a gain setting should be normalised to 0dB, but in others it is less so. In the listing of all the variables in Section 8 the normalised value is shown.

Any variable can be individually set to its normalised value by pressing the *s* and *t* buttons at the same time.

Within each the Main Menu at the end of the list of Sub Menus is a pseudo Sub Menu called **Norm**. Selecting into this will let you normalise all the parameters within the Main Menu item to their normalised value.

The three LEDs beside the *s* and *t* buttons are used to show whether the variable is calibrated or not. After calibration the **CAL** LED will be ON.

4.2 REMOTE CONTROL

In addition to being controlled with the menu system on the front panel the V1643 can also be controlled over the DART remote control system. For this it should be fitted into a rack which also contains a Rack Controller. The Rack Controller provides an interface between all the units in the rack and the external DARTNET network. Various controlling devices are available for accessing units on the DARTNET; these include the V1605 1U hardware panel, the ViewFind PC program and the more sophisticated ViewNet Client Server interface. It is also possible to have third party software written to interact with DARTNET. The details and specification of the DART interface are described elsewhere.

There are separate settings for the unit when operating in Local and Remote control modes. This means that if the unit is changed between Local and Remote mode then the settings may change. The advantage of this is that if the unit has been set up locally and the operator inadvertently changes to Remote mode (which probably has different, or even default, settings) the local settings are not lost. There could be a disadvantage in that once the unit has been set up remotely it cannot not be switched to Local without causing a disturbance.

When in Remote Control the front panel menu system is still active but is only used to monitor the status of the unit. It cannot be used to change anything. There are in fact some exceptions to this since some parameters cannot be controlled remotely. For these, which are listed below, it is always possible to use the front panel to change them.

FRM SYNC	XstdMode	Set the Cross standard mode
ENG' ING	Free-run	Set the Oscillator into Free run
ENG' ING	FailMode	Set the Input Fail mode to Kill rather than digital Black
ENG' ING	TPs	Set the Test Patterns to Full Field
ENG' ING	Sleep	Set the display Sleep timeout
ENG' ING	LEDLevel	Set the Display brightness
ENG' ING	525F1L21	Blank/Pass Line 21, Field 1 (525 mode only)
ENG' ING	525F1L22	Blank/Pass Line 22, Field 1 (525 mode only)
ENG' ING	525F2L21	Blank/Pass Line 21, Field 2 (525 mode only)
ENG' ING	525F2L22	Blank/Pass Line 22, Field 2 (525 mode only)
CONFIG	Banner	Turn the top level display Banner On or Off
CONFIG	GPI 1	Set the application for GPI 1
CONFIG	GPO	Select GPO function of the DELAY Output

4.3 FRAME SYNCHRONISER

4.3.1 SDI Inputs

The SDI inputs must conform to SMPTE 259M or its equivalents. If only one input is required then it should be connected to SDI 1 and then SDI 2 may be set up to be either a buffer output or a synchronised output. For this the on board links must be set correctly:

Buffer Output	LK2, LK3 North
Synched Output	LK2, LK3 South

If two SDI inputs are needed then the links should be set as follows:

Input 2	LK2, LK3 West
---------	---------------

In this case there is no access to the buffer output and only one synched output is available with the 3U rear panel and two with the 1U rear panel.

The control processor will know whether input 2 is available and if so it will appear on the selection menus. If it is not available then it will not appear on the menu. This applies to local control and any remote controller on DART should act in the same way. (All Vistek supplied control software will conform, but third party software is outside of our control.) From the front panel you can see if SDI 2 is available on the **STATUS : SDI I/P2** menu.

Apart from the Front Panel or remote control SDI 2 can be selected using one of the three available GPIs. See section 4.4.1.

Since Firmware version 1.1.0 it is possible to indicate on the dual purpose Delay/GPO output that SDI 2 has been selected, by whichever method. See section 4.4.2.

4.3.2 SDI Buffer Output

The SDI buffer output is simply an equalised version of Input 1. The SDI signal is equalised, but not re-clocked. It is only available on the SDI 2 BNC connector if the links are set correctly:

Buffer Output	LK2, LK3 North
---------------	----------------

4.3.3 SDI Main Output

The main synchronised SDI output is available on several BNCs depending on the type of rear and the link set up:

3U Rear	LK2, LK3 North or West	BNC 3
	LK2, LK3 South	BNCs 2 and 3
1U Rear	LK2, LK3 North or West	BNCs 3 and 4
	LK2, LK3 South	BNCs 2, 3 and 4

4.3.4 Video Reference

The external video reference should be a standard composite black and burst video signal. It is possible to use a real video signal but this is not recommended for high quality systems. The rear panel provides the option of looping the reference through another BNC which is shared with the Delay output. If the rear panel switch is set to REF LOOP then the Delay signal is not available on a BNC but is still present on the multi-pin connector as shown in section 2.2.

Whether the reference is looped or not there is the option of terminating it on the PCB as controlled by link LK 5.

High Impedance	LK 5 North
Terminated in 75Ω	LK 5 South

4.3.5 SDI Input Fail

If the selected input should fail then the V1643 will immediately stop writing into the frame store and will start to read data only from the other field. (This is the opposite field to that which was being written when the input failed.) Since only one field is being displayed there will be a loss of vertical resolution, but there should be no motion judder.

It is usual on Frame Synchronisers for the image to be frozen when the input fails. This is especially useful when there is likely to be occasional and intermittent breaks in the signal to give a minimum disturbance to the output. However this can be very confusing when installing a system with static test patterns since it is hard to trace the signal. On the V1643 there is the option of freezing the picture for a short period and then cutting to black. The default period is 3 seconds, but this can be varied from 0 to 14 seconds, and even set to an infinite freeze. The freeze delay is set on the **FRM SYNC : VFL Mode** menu.

When the output of the module goes to Black after the set delay it is also usual that this is a clean digitally generated black, so that any following equipment sees no disturbance. However there may be cases where this is not desirable, for instance if downstream equipment also needs to be aware that the signal has failed and therefore take some action. For this reason it is possible for the output can be corrupted on SDI Input Fail rather than go to a clean black. In this case the digital signal to the serialiser is disabled, and the serial output is grossly non-standard. This feature is set in the **ENG'ING : FailMode** menu which can be set to either Black or 0V. Note that it is not possible for the serial output to be completely disabled, but only set to a non-standard signal. This feature is only available from firmware version 1.4.6 onwards.

When the unit goes into freeze mode from the SDI Input Fail the vertical blanking interval data will always be blanked, as will the ancillary data. This prevents normally dynamic data being read out from a static store. In particular it prevents Teletext and embedded audio being completely corrupted.

4.3.6 Video Reference Fail

If the video reference fails, or simply is not be present, then the synchroniser will normally lock to the SDI input and set itself into minimum delay. In this way the unit can still be used as a SDI Video Proc Amp (if enabled) and all the audio functions are still available (again only if they are enabled).

If the unit is wanted as a variable delay device then this setting back to minimum delay can be overwritten so that the unit goes into variable delay on the **FRM SYNC : RFL Mode** menu. If this is set to variable then the current offset settings will be used to adjust the output timing relative to the SDI input rather than the video reference.

4.3.7 Standard Detection

The V1643 automatically monitors the selected SDI input and the video reference to detect which standard they are – either 625/50 or 525/60. If they are the same standard then the unit will operate accordingly.

However, if they are of opposing standards then there is a choice as to how the system operates. Normally the input standard will be ignored and the unit will continue to lock to the applied external reference. This means the output will always be 'clean', in the sense of producing no errors on the SDI output signal, whatever happens to the input signal, but the signal of course will not be processed correctly. But there are instances when it is preferable to follow the standard of the input signal rather than the reference so it is possible to change the operation on the **ENG'ING : X std** menu. This is normally set to REF, but can be changed to IP. In this case the unit will operate from the input just as if the reference were not present at all and will automatically go into its minimum delay mode so that any H or V offsets will be ignored.

This is summarised in the following table:

SDI I/P	Reference	Cross Standard = Ref		Cross Standard = IP	
		Operating Standard	Locking Source	Operating Standard	Locking Source
None	None	Last used	Free Run	Last used	Free Run
	625/50	625/50	Ref	625/50	Ref
	525/60	525/60	Ref	525/60	Ref
625/50	None	625/50	Input	625/50	Input
	625/50	625/50	Ref	625/50	Ref
	525/60	525/60	Ref	625/50	Input
525/60	None	525/60	Input	525/60	Input
	525/60	525/60	Ref	525/60	Ref
	625/50	625/50	Ref	525/60	Input

4.3.8 Manual Freeze

Apart from the automatic freeze of the video when the input fails it can also be frozen by the operator. This can be done in three ways:

1. Locally on the front panel
2. Remotely over DART
3. From the GPI connections on the rear.

In all cases the freeze is clean in that it occurs on a field boundary, so that either of the two fields may be shown.

Locally there is a choice of three freezes – Field 1, Field 2 or Frame. If the unit is put into any of these Freeze modes manually and the power is removed then this is not remembered, so it will not wake up again in Freeze mode.

Remotely or over the GPI there is only the option of freezing either Field or Frame. On a Freeze Field the next full field will be continually displayed. Thus if the command is received during Field 2 then although both fields are frozen only Field 1 will be displayed on both output fields. On a Freeze Frame writing will stop at the end of the current frame and it will then be repetitively read out.

Setting up of the GPIs is described in section 4.4.1.

When the unit is in freeze mode the vertical blanking interval data is blanked so as to prevent normally changing data, such as Teletext or time-code being frozen. This applies to an automatic freeze from an input SDI fail as well.

Also when in Freeze mode, either automatic or manual the all ancillary data is blanked independently of the main control for this (**ENG'ING : Anc Data** menu).

4.3.9 Vertical Interval

There is individual control of which active lines in the vertical blanking interval are passed through the Frame Synchroniser. The exact lines which can be selected depends on the operating standard and are shown here using the usual line numbering conventions for the particular standard:

Standard	Field 1	Field 2
625/50	Lines 7 – 22	Lines 320 – 335
525/60	Lines 10 – 20	Lines 10 – 19

If the unit is operating in 525/60 then the selection menu will only show the lines available in that standard.

The lines are selected in pairs across the two fields, so that if, for example, you wish to pass Line 12 on Field 1 then you will have to also pass Line 12 on Field 2.

This only selects whether the active picture part of the VBI is passed, that between the SAV and EAV, and not the ancillary data which is discussed in section 4.3.13.

Changing the VBI selections is a little different to the other menus. First go to the **ENG'ING : VBI** menu and select whether you want all lines to be Passed, or all to be Blanked or to Sel to make a selection. Only if you have selected Sel will there be the individual lines pairs on the **ENG'ING** menu below **VBI**. The easiest way to do this is to decide whether you want the majority of lines to be passed or blanked and set the unit accordingly, then change to Sel and change those lines you want to be different.

4.3.10 Special Vertical Blanking (525 Mode only)

Some active picture lines are used for carrying data even though they are nominally in the active picture region. A particular example of this is the carrying of Closed Caption data on Line 21 of Field 1. Sometimes this line needs to be blanked quite separately from other lines and the other field.

To do this there are special menu entries in **ENG'ING** for the individual control of 4 lines: 21 and 22 on each field.

Only the blanking of Line 21, on each field, can be controlled over the remote control system, but the local control is always active. This means that Line 21 access can still be controlled even if the unit is set to Remote Control.

4.3.11 Minimum Delay

The Frame Synchroniser can be set into a minimum delay mode which can also be considered as a synchroniser bypass. This is done on the **FRM SYNC : Vid Del** menu.

Note that when set into the Minimum Delay the unit will not be synchronising to the reference, so it may appear not to be working. For this reason the high level Banner message (section 4.1.5) will carry a warning.

The minimum delay for both standards is 3.66µs.

4.3.12 Delay Signal

The Frame Synchroniser produces a signal that represents the delay being inserted into the video path. Normally this is used internally by the audio processor to provide a tracking delay to the audio. However the signal is also available externally so it can be used by other audio tracking devices.

From version 1.1.0 onwards the Delay output may be used as a General Purpose Output (GPO) instead of delay. This is set in the **CONFIG : GPO** menu and is described in more detail in section 4.4.2.

The Delay signal has repetition rate of two frames (80ms for 625/50 and 66.7ms for 525/60) and the positive pulse width represents the delay. This is shown in this diagram.

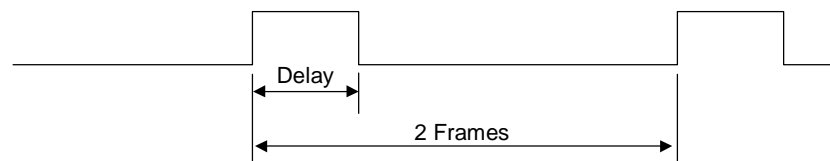

If the unit is not synchronising, such as loss of i/p or Freeze then the delay output is blanked. It is expected under these conditions that the audio processing will hold its current delay from the last valid measurement until a pulse re-appears. This is what the internal audio delay does.

The external Delay Pulse output is available on the rear panel in two places – a BNC shared with the Reference loop output, and on the high density D type connector. For the BNC output the

switch on the rear panel must be set to the correct position. For the D-type it is on pin 27 and is always available.

The external pulse itself is nominally TTL level (0 to 5V) at 75Ω but is fed from an emitter follower.

4.3.13 Ancillary Data

Ancillary data is all the information embedded in the D1 data between the EAV and SAV TRSs. In most installations this is digital audio and EDH data but can include any other data that is embedded using the appropriate standard. It must be remembered that the V1643 is a Frame Synchroniser and periodically there could be a time when the output timing rolls through the input timing such that there is either a frame repeat or a frame drop-out. There is no protection of the ancillary data when this occurs.

The V1643 provides the ability to blank the ancillary data with the video processing. This provides a 'clean sheet' for the re-multiplexing process and is the only way to replace audio within an existing group. It is done on this menu:

ENG'ING Anc Data

Incidentally this blanking will also remove the EDH signal from the input, but this is usually replaced on the output anyway. However there can be a problem if the output EDH is disabled and the original EDH is passed through (Ancillary Data pass) since the original EDH does not relate to the processed data. This could result in EDH errors on downstream detection equipment.

4.3.14 TRS Signals

The TRS signals are the digital equivalent of the analogue synchronising pulses. The V1643 always regenerates the TRS signals on its output, so that any errors on the input signal will not be propagated through.

4.3.15 Test Patterns

The V1643 contains a useful test pattern generator which can be used to provide suitable signals for system testing and even for testing other pieces of equipment. They are selected as if they were an alternative signals source on the **FRM SYNC : video** menu. From the remote control system they can be called up directly.

The patterns available are:

Black	Digitally generated Black
Bars	For 625/50 operation these are 75% (EBU) Bars For 525/60 operation these are SMPTE Bars
100% Bars	Always 100% Colour Bars
Timing	A reference timing signal which marks the first and last luminance and chrominance pixels in the digital active line, and the first and last active lines in each field. It also marks the centre pixels and centre lines for each format.
Ramps	A progressive luminance and chrominance ramp on all lines which goes from the legal minimum (004H) to the legal maximum (3FB) precisely over a digital line.
Stress	The standard two part pathological stress signal which fully exercises the equaliser and clock recovery PLL on subsequent equipment.

Even though the test patterns are selected as if they were alternative inputs to the unit they are actually generated on the output. This means that selecting them will not destroy any data already in the frame store which may, of course, be frozen. It also means that it is possible to cut cleanly between them and the real input video. It also means that they cannot be used as an internal confidence signal for proving the correct operation of the V1643 itself.

Normally the actual test patterns are only produced during the active lines of each field but they can be set to also work during the vertical blanking interval. This is discussed in section 4.4.5.

The vertical interval is considered to be a part of the Test Pattern so it is always synthesised as either Black or the pattern itself. This means that the vertical blanking interval is always blanked when Test Patterns have been selected.

Conversely the Ancillary Data in the horizontal blanking interval is still passed through, assuming that option has been selected on the Engineering menu, even when Test Patterns have been selected. This is because the horizontal interval is usually audio, rather than the video in the vertical interval, and this should be handled separately.

4.3.16 EDH

EDH is a method of embedding data within the ancillary data space which carries a measurement of the video and other data. By regenerating the equivalent measurement at the receiving end it is possible to check that the data has been received correctly.

The V1643 does not process the EDH data on the incoming SDI video, but it does regenerate new EDH data on the output. EDH is always put in the same place, so the new data will overwrite the old.

The generation of the new data can be disabled on the **ENG'ING : O/P EDH** menu. Care must be taken if the new EDH generation is disabled and the old EDH is being passed through because it will probably not correctly represent the data. In this case the Ancillary Data really ought to be blanked on **ENG'ING : Anc Data**.

4.4 SYSTEM

4.4.1 GPIs

The V1643 has a single GPI so that external hardware can simply select certain parameters. The GPI input all has a 4k7 pull-up resistor to +5V, and the external hardware should take the pin to Ground to activate the GPI. The GPI input is on a rear panel BNC.

The options for the GPIs are as follows:

CONFIG	GPI	OFF	GPI disabled
		FZFD	Freeze Field
		FZFM	Freeze Frame
		SDI2	Select SDI I/P 2 (I/P 2 must be enabled on LKs 2 and 3)
		BARS	Select Colour Bars

4.4.2 GPO

The V1643 has a DELAY output (as described in section 4.3.12) which, from version 1.1.0 onwards, can be used as a General Purpose Output (GPO).

There is a choice of functions for this GPO which are set as follows:

CONFIG	GPO	DELAY	Standard DELAY Output - default
		PWR GOOD	Low for no power, or FPGA not programmed.
		IP FAIL	Indicates the selected input is not present
		SDI 2	SDI 2 is selected, either locally or remotely (GPI)
		RF FAIL	Reference is not present

4.4.3 VCO Centre Frequency

Normally, the output of the V1643 is locked to the video reference, if present and of the same standard as the video, or to the input video itself. If there is no signal or reference connected then the output will free run at the nominal centre frequency of the on board crystal. This centre frequency can be adjusted under the **CALIB : CntrFreq** menu, but this should not normally be necessary in the field.

It is possible to force the unit into its free-run mode using the **ENG'ING : Free-run** menu. This is an unusual requirement and so is a setting that appears on the top level banner when set.

4.4.4 Version Numbers

There are four separate items of software/firmware in the V1643 and they all have separate version numbers. These can be read on the following read only menus:

STATUS	Softver	0.00.00	The operating code
STATUS	Audiover	0.00.00	Actually the control FPGA data
STATUS	Videover	0.00.00	The Video FPGA data

4.4.5 Test Patterns

The use of the test patterns was discussed in section 4.3.15.

Normally the test patterns only occupy the active video lines, but there are times when it may be useful to have them in the Vertical Blanking Interval as well. For example this could be used to test the blanking performance of equipment downstream. The test patterns can be set to be Full Field or active picture only on **ENG'ING : TPs**.

ENG'ING	TPs	norm	Active picture height
		FF	Full Field

4.4.6 Cross Standards

There are different requirements from users as to how the unit should operate when the SDI input and video reference are of opposite standards. Some operators would like the unit to ignore the reference in this case and switch into minimum delay mode locked to the SDI input. This is useful if the input may be of either standard, but the output will be used either directly or routed through a Standards Converter which, of course, also usually acts as a synchroniser in its own right. However many other users expect the output to always be locked to the reference, if present, and use it to always produce a clean output. 'Clean' in this instance means that the output fully meets the CCIR Rec. 601 specification. This would not be the case if the unit were to follow the input under cross-standard conditions.

The effect of this cross-standard operation was also discussed in section 4.3.7.

So the V1643 has a control for setting up the required conditions on the Engineering menu:

ENG'ING	Xstd	IP
		Ref

4.4.7 Illegal Codes

A function of the V1643 is to ensure that the SDI output always meets the CCIR Rec. 601 specification. In particular this means that the output is always legal in the sense of Line Length, Field Length and data values. In the main this works extremely well, but there are some circumstances where it fails:

1. If the output timing is being changed, there will be momentary errors.
2. If the input is noisy, such that erroneous data is received, then the ancillary data may get checksum errors. This obviously only applies if the Ancillary data is being passed. The video will be alright, since the EDH is regenerated on the output.
3. If the reference is unstable or changing standards then the output will not be stable.
4. If cross-standard operation is set to use the Input, then any momentary standard change on either the input or the reference will cause the locking loop to jump from one to the other which will cause errors.

4.4.8 525 V-BIT of TRS

There has been some inconsistency in the 525 D1 standard in regard of the number of line within the vertical blanking interval for which the V-bit is set in the TRS. Early versions of CCIR Rec. 656 (1986) called for it to be active only for 10 lines per field in 525/60 signals. However it became

common practice for a longer V-bit so as to be active for all the non picture lines and much equipment has been produced like this. Recently the original specification has again come to the fore.

So the V1643 normally produces the proper CCIR Rec. 656 V-bit, but it is possible to produce the longer version using the **ENG'ING : 525 VBit** menu:

```
ENG'ING    525 VBit    Long
                               Short
```

This option is only available if the unit is operating in 525/60 mode.

4.4.9 Display Sleep

Since, for the vast majority of its life, the V1643 will operate behind the front panel of a rack frame the display on the local front panel will not be visible so it will go to sleep after a certain time. This timeout delay can be changed on the **ENG'ING : sleep** menu to be anything between 0 and 30 minutes; 0 minutes means that it will stay on indefinitely. The sleep timeout always counts from the last front panel button push. The default time is 5 minutes.

The panel can also be forced into its sleep mode by moving up a level from the Top Level menu which displays the module type, **v1643** etc.

To get the display to come on again simply press one of the buttons and the menus will start again at the Top Level.

4.4.10 Display Brightness

The brightness of the front panel display can be adjusted on the **ENG'ING : LEDLevel** menu.

```
ENG'ING    LEDLevel    z z z z
```

5. CALIBRATION

This section describes how to calibrate the unit as it is done in the factory. The V1643 does not contain any potentiometers, but like most equipment with analogue parts still needs to be calibrated. Normally this calibration is done in the factory and should not need to be repeated in the field but this section describes the procedure and is included for completeness.

High quality, calibrated test equipment should be used for this calibration. Note that it is not possible to return to the pre-calibration settings other than by making a note of the values and re-entering them.

5.1 SET-UP

There is a separate Main Level Menu for Calibration and this should be used throughout. The first sub-level menu is Cal Mode which can be used to turn calibration ON:

```
CALIB      Cal Mode  Cal Off
                        Cal On
```

The calibration mode must be turned ON before any parameter can be adjusted. The calibration mode will be turned OFF in one of four ways:

1. Manually on the **CALIB** : **Cal Mode** menu.
1. By going up to the Top Level Menu
2. By re-powering the unit.
3. By letting the display timeout and go to sleep mode.

When the calibration mode is on then the unit will automatically set up the required conditions in the unit as you enter each sub-menu. For example if you go into the CntrFreq sub-menu the unit will automatically go into free run. Similarly if you go into a DAC calibration menu it will produce tone onto that channel. For obvious reasons this should not be done on a unit that is being used On Air.

5.2 FREE-RUN FREQUENCY

The V1643 has a voltage controlled crystal oscillator which is usually locked to the external video reference or to the input video. However if there is no input or reference then it will free-run and this free running frequency should be set. The oscillator on the V1643 is not accurate enough to be used as a frequency reference but nevertheless should be set close to the ideal so that any succeeding SDI equipment will be able to lock to its output, and so that when in free run it will only drift slowly away from its starting reference.

To calibrate the frequency set the unit into Free Run by turning Cal Mode ON and selecting the CntrFreq sub-menu.

```
CALIB      Cal Mode  Cal On
```

Now monitor the clock frequency on TP 50 (Issue B and C PCB), or compare the output picture movement on a monitor with an accurate external reference and adjust the frequency on.

```
CALIB      CntrFreq      Range is -127 to +128
```

The setting is stored on the unit in non-volatile memory, and should not need regular adjustment.

6. TROUBLE SHOOTING GUIDE (FAQS)

This section is to be a help in solving some common difficulties with the V1643. If there is no control from the front panel first check that the switch is set to Local.

6.1 VIDEO

Symptom	Possible explanation
The output is Black, even after powering down and up.	<ol style="list-style-type: none"> 1. There is no input and the Video Fail Mode is set to Black, or Freeze then Black 2. Black test Pattern has been selected 3. The Proc Amp has been faded to Black either by control or GPI. 4. SDI 2 is enabled and selected.
The output is badly corrupted, with no video data	The Video Fail mode is set to 0V rather than Black, and there is no input.
The Error light on the Tek 601M is ON.	The unit is set to pass ancillary data, but the O/P EDH is off, so the incoming EDH is being passed straight through despite the processing within the V1643. Either blank the ancillary data or enable the O/P EDH.
The O/P EDH is not the same as the I/P EDH	First check that the Proc Amp is normalised. Then check whether the incoming signal has over-white or sub-black levels. These may be changed by the Soft Clipping feature
EDH not stable on a test signal	Check whether the Proc Amp is normalised. If there is any gain added then the Dynamic Rounding will cause a varying EDH value.
There is no Vertical Interval data	<ol style="list-style-type: none"> 1. The VBI blanking is not set correctly in the ENG'ING menu. 2. The unit is generating a Test Pattern.
Cannot change video timing	Probably because there is no reference and the Ref Fail Mode is set to Min Delay.

6.2 OTHERS

Symptom	Possible explanation
Display never goes to sleep	Check whether the Sleep delay has been set to 0 Mins which means stay awake.
A GPI does not work	Check for GPI priority. GPI 1 overrules GPI 2 which overrules GPI 3. Each one can be checked on STATUS : GPI STA.
Front panel can change but there is no control	The unit is probably in Remote mode. The panel is still life for monitoring.
Lots of errors on the Alarm LED on a Tektronix WFM 601.	<ol style="list-style-type: none"> 1. Changes are being made to the output timing, perhaps over the remote control system. 2. The input SDI is changing standards and the unit is set to follow the input standard when receiving cross-standard signals 3. A noisy SDI input is causing errors in the Ancillary data, which appear on the WFM 601 as ancillary checksum errors.

7. FRONT PANEL MENUS

The next three sections show the menus available on a V1643.

Some menu items may only appear with certain configurations. For example the Mux Src under Audio is only present if the sub-module has a digital output and it is configured for Input on its second port, rather than another output.

7.1 V1643

FRM SYNC	STATUS	ENG'ING	CALIB	CONFIG
Video	Options	ANC Data	Cal Mode	Sub-Mod
Hor Tim	SDI I/P	FailMode	CntrFreq	GPI ⁴
Ver Tim	REF I/P	525 Vbit ¹	norm	GPO ⁴
Freeze	AES Ref	O/P EDH		Banner ⁴
VFL Mode	SDI I/P2	Free-run ⁴		Password
RFL Mode	I/P Grps	TPs ⁴		Options
XstdMode ⁴	DMX Aud	Sleep ⁴		TestMode
Vid Del	Mux Grp	LEDLevel ⁴		
Delay	GPI STA	VBI		
norm	Soft Ver	VBI 7 ²		
	AudioVer	VBI 8 ²		
	VideoVer	VBI 9 ²		
		VBI 10 ³		
		VBI 11 ³		
		VBI 12 ³		
		VBI 13 ³		
		VBI 14 ³		
		VBI 15 ³		
		VBI 16 ³		
		VBI 17 ³		
		VBI 18 ³		
		VBI 19 ³		
		VBI 20 ³		
		VBI 21 ²		
		VBI 22 ²		
		525F1L21		
		525F2L21		
		525F1L22		
		525F2L22		
		norm		

¹ Available with 525/60 video only.

² Available with 625/50 video and VBI in Select mode.

³ Available when VBI in Select mode only.

⁴ Also available when in Remote Control.

8. CONTROLS

These tables show a complete list of all the parameters that can be controlled locally for the various configurations. Unless otherwise shown they can also be controlled over the DART remote control system. Not all menus are available at any one time, since they depend on which module type may be fitted, and sometimes on the operating conditions.

The tables also show the full range of the controls and their ranges and normalised value, if appropriate. The normalised value or setting is shown by the 'n'.

8.1 FRAME SYNCHRONISER - FRM SYNC

FRM SYNC	Video	IP SDI1	n	
		IP SDI2		If enabled
		BLK		
		BARS		
		100%BARS		
		TIMING		
		RAMPS		
		STRESS		
	Hor Tim	+0.00us	n	
		β		
		+63.96ms		for 625/50
		+63.52ms		for 525/50
	Ver Tim	-128		
		β		
		+0	n	
		β		
		+127		
	Freeze	Run	n	
		Frz Fld1		
		Frz Fld2		
		Frz Frm		
	VFL Mode	Black	n	
		1 sec		
		β		
		14 sec		
		Freeze		
	RFL Mode	Min Del	n	
		Var Del		
	XstdMode	Xstd Ref	n	
		Xstd I/P		
	Vid Del	Vdel Var	n	
		Vdel Min		
	Delay	DEL <1FD		Status display only
DEL >1FD				

8.2 OPERATING CONDITIONS – STATUS

STATUS	Options	V1643		Basic Unit	
	SDI I/P	IP 625 3			
		IP 525 3			
		IP FAIL			
	REF I/P	RF 625 3			
		RF 525 3			
		NO REF			
	SDI I/P2	SDI 2 NA			
		SDI 2 OK			
	I/P Grps	None			No groups occupied.
	GPI STA	1 ⁻			⁻ P Inactive. - P Active.
	Soft Ver	01.00.00			The operating code
	AudioVer	01.00.00			The Control FPGA code (historically audio)
VideoVer	01.03			The Video FPGA data	

8.3 ENGINEERING – ENG'ING

ENG'ING	Anc Data	Anc Blnk	n		
		Anc Pass			
	FailMode	FM Blk	n		Fail Mode to Black
		FM 0V			Fail Mode to 0V
	525 vbit	Long	n		
		Short			
	O/P EDH	EDH On	n		
		EDH Off			
	Free-run	Free Off	n		
		Free On			
	TPs	TPs Norm	n		
		TPs FF			Test Patterns in active picture only
	Sleep	5 min	n		Full Field Test Patterns to include the VBI
	LEDLevel	■ ■ ■			Variable 0 to 30 minutes.
	VBI	VBI All			
		VBI Sel			
		VBI None			
	VBI 7	L7 Pass	n		
		L7 Blank			
	VBI 8				Individual lines only available if VBI is set to VBI Sel . VBI 8 to VBI 22 are as VBI 7 VBI 7, 8, 9, 21, 22 are only available in 625/50
	VBI 9				
	VBI 10				
	VBI 11				
	VBI 12				
	VBI 13				
	VBI 14				
	VBI 15				
	VBI 16				
	VBI 17				
	VBI 18				
	VBI 19				
	VBI 20				
	VBI 21				
VBI 22					
525F1L21	F1L21On	n			
	F1L21Off				
525F1L22	F1L22On	n		525 Mode Only.	
	F1L22Off				

	525F2L21	F2L21On	n	Individual Control of Closed Caption Lines.
		F2L21Off		
	525F2L22	F2L22On	n	
		F2L22Off		

8.4 CALIBRATION – CALIB

CALIB	Cal Mode	Cal Off	n	Must be set ON to enable correct conditions during calibration
		Cal On		
	CntrFreq	Frq=-128		Free-run Frequency
		Frq=+20		
		Frq=+127		

8.5 CONFIGURATION – CONFIG

CONFIG	GPI	OFF	n	
		FZFD		
		FZFM		
		SDI2		
		BARS		
	GPO	DELAY	n	
		PWR GOOD		
		IP FAIL		
		SDI 2		
		RF FAIL		
	VB Mode	VB F1&F2	n	Configure Fields for Vertical Blanking.
		VB F1		
		VB F2		
	Banner	On	n	
		Off		
	Password	0		
	TestMode	Off	n	
		On		Password required

8.6 TEST MODE – TEST

This section is not required for users, but is shown here for completeness.

TEST	AUD_ERRA	0000	n	
		1F01		
	DMX_STA	00000000	n	Demux Status
	AUD_ERRB	0000	n	
		1F01		
	DSP_OPFL	0000	n	
		6101		
	SRC_VERS	14141414		Sample Rate Converter version numbers
	DMX_REV	GS9023A		Gennum Demux Chip revision
	MUX_REV	GS9023A		Gennum Mux Chip revision

9. FIRMWARE VERSIONS

This table gives a brief summary of the various versions of software that have been issued with the corrections and improvements for each. This has been included in this manual so that users with earlier versions can understand when some facilities, or menu options may not appear.

VERSION	DATE	REMARKS
1.1.0	22-03-06	GPOs on Delay Output I/P Fail to 0V option
1.0.1	01-04-04	Initial Issue