



V635X Series

SDI Audio Mux and Demux

INSTALLATION and OPERATION

© Vistek Electronics Ltd

Filename: v635XSeriesom_11.doc
Issue : 1.1
Date: February 2005

VISTEK Electronics Ltd
Wessex Rd
Bourne End
Buckinghamshire, SL8 5DT
ENGLAND

Tel. +44 1628 531221
Fax. +44 1628 530980
Web: www.vistek.tv

CONTENTS

1.	DESCRIPTION	5
1.1	GENERAL	5
1.2	MODULES	6
2.	INSTALLATION	7
2.1	REAR PANELS	7
2.2	POWER REQUIREMENTS	7
2.3	SIGNAL CONNECTIONS	7
2.3.1	Video	7
2.3.2	Audio	8
2.3.3	GPI Connections	9
2.4	SIGNAL SPECIFICATIONS	9
2.5	VIDEO INSERTION DELAY	9
2.6	ADJUSTMENT RANGES	10
2.6.1	Video Adjustments	10
2.6.2	Audio Gain Ranges	10
2.6.3	Audio Input Settings	10
2.6.4	Audio Routings	10
2.6.5	Audio Delay	11
2.7	HARDWARE	12
2.7.1	The PCB	12
2.7.2	Links and Switches	12
2.7.3	Fuse	12
2.7.4	Audio Sub-module	12
2.7.5	Video Sub-module	12
2.7.6	Fibre Sub-module	12
2.8	FRONT PANEL	14
2.8.1	Direct Indications	14
2.8.2	Display and Switches	15
2.8.3	Remote/Local Control	15
3.	BLOCK DIAGRAMS	16
3.1	GENERAL	16
3.2	V6351 Dual Multiplexer	16
3.3	V6351Q Quad Multiplexer	17
3.4	V6353 Dual Demultiplexer	17
3.5	V6353Q Quad Demultiplexer	18
3.6	V6353Q Quad Demultiplexer – Split Mode	18
3.7	V6355 Demultiplexer - Multiplexer	19
3.7.1	DMX – MUX, no Audio Module	19
3.7.2	DMX – MUX, I/P Audio Module	20
3.7.3	DMX – MUX, O/P Audio Module	20
3.7.4	DMX – MUX, I/O Audio Module (Track Mode)	21
3.7.5	DMX – MUX, I/O Audio Module (Audio Split Mode)	21
3.8	Audio Processing	22
4.	SYSTEM OPERATION	23
4.1	FRONT PANEL	23
4.1.1	Start up	23
4.1.2	Menu Control	23
4.1.3	Menu Examples	24
4.1.4	Sleep	24
4.1.5	Brightness	24
4.1.6	Banner	25
4.1.7	High Level Signal Status	25
4.1.8	Variable Calibration	25
4.2	REMOTE CONTROL	26
4.3	VIDEO PROCESSING	26
4.3.1	SDI Input	26
4.3.2	Reference and Locking	26
4.3.3	Split Mode	27
4.3.4	Standard Detection	27
4.3.5	Ancillary Blanking	27
4.3.6	Vertical Interval	27
4.3.7	TRS Signals	27
4.3.8	EDH	27
4.3.9	Illegal Codes	28

CONTENTS (Cont'd)

4.4	AUDIO GROUPS	28
4.5	AUDIO MULTIPLEXING	30
4.6	AUDIO DEMULTIPLEXING	31
4.7	AUDIO PROCESSING	31
4.7.1	Input Processing	31
4.7.2	Routing.....	32
4.7.3	Delays	32
4.7.4	Output Processing.....	33
4.7.5	Channel Status	33
4.7.6	Maximum Audio Level (MAL)	33
4.8	SYSTEM	34
4.8.1	GPIs	34
4.8.2	VCO Centre Frequency.....	34
4.8.3	Version Numbers	34
4.8.4	Display Sleep	34
4.8.5	Display Brightness	34
5.	CALIBRATION.....	35
5.1	SET-UP.....	35
5.2	FREE-RUN FREQUENCY.....	35
6.	TROUBLE SHOOTING GUIDE (FAQS).....	36
6.1	VIDEO.....	36
6.2	AUDIO.....	36
6.3	OTHERS.....	36
7.	FRONT PANEL MENUS.....	37
7.1	V6351 – Dual Mux	37
7.2	V6351AP – Dual Mux with AP	37
7.3	V6351Q – Quad Mux	38
7.4	V6351QAP – Quad Mux with AP	38
7.5	V6353 – Dual Demux.....	39
7.6	V6353AP – Dual Demux with AP.....	39
7.7	V6353Q – Quad Demux	40
7.8	V6353QAP – Quad Demux with AP	40
7.9	V6355 – Demux/Mux	41
7.10	V6355AP – Demux/Mux with AP	41
8.	CONTROLS	42
8.1	Video and Groups - MAIN.....	42
8.2	Audio Processing – AUDIO.....	42
8.3	Operating Conditions – STATUS	44
8.4	Engineering – ENG' ING.....	45
8.5	Calibration – CALIB.....	46
8.6	Configuration – CONFIG	46
8.7	Test Mode – TEST	48
9.	SOFTWARE VERSIONS	49

Intentionally Blank

1. DESCRIPTION

1.1 GENERAL

The V6351 Series is a family of modules in the Vistek V1600 product range for working with embedded audio. They all work with SDI video and can process either analogue or digital AES audio. The standard units work with two AES channels which fit into one Group of embedded data, while the Quad units work with four AES channels which fit into two Groups. The family consists of multiplexers, de-multiplexers and a de-multiplexer-cum-multiplexer.

There is a companion range of products, V6751 series, which has all the same features as the V16351 series but with Fibre I/O giving the addition of an optical input or output. The optical interfaces are all single-mode fibre using lasers of various wavelengths. These allow the use of the series for fairly long range links of both video and audio, without the need for separate fibre interfaces.

All modules have three SDI video ports. One is a permanent input, one is a permanent output, while the third is selectable using links. When set by the links as an output the second port is a replica of the primary output, but when set as a second input the user can easily select between the two video sources. The selection can be from the front panel or over the remote control. The unit can automatically detect the standard of the input SDI video (525/60 or 625/50) and operate accordingly or it can be forced into one of the two standards.

It is not necessary to have an input for the multiplexing modules. They have an internal digital Black generator, and this can be used to embed audio should there be no input.

An audio processing option is available, AP, which allows the user to adjust many of the audio parameters. These range from the input and output gains to forcing Mono, Left/Right Swap, and routing and mixing the outputs from various input sources.

The audio I/O is determined by the type of audio sub-module fitted. Types available are for Digital I/P and O/P and Analogue I/P and O/P. The multiplexers are fitted with I/P sub-modules and the demultiplexers with O/P ones. The de-multiplexer-cum-multiplexer can be fitted with either.

The modules are fully compatible with the DART remote control network for which there is a selection of hardware and software control systems.

1.2 MODULES

This table shows the various audio sub-modules in the series. When the module is powered up the front panel will show its type as in the Display column.

Product	Desc.	Display	Audio sub	Comments
V6351 / A	Dual Mux	V6351	130-3760	Analogue I/P
V6351 / D			130-3710	Digital I/P
V6351 / A / AP		V6351AP	130-3760	Analogue I/P
V6351 / D / AP			130-3710	Digital I/P
V6351Q / A	Quad Mux	V6351Q	130-3760	Analogue I/P
V6351Q / D			130-3710	Digital I/P
V6351Q / A / AP		V6351QAP	130-3760	Analogue I/P
V6351Q / D / AP			130-3710	Digital I/P
V6353 / A	Dual Demux	V6353	130-3750	Analogue O/P
V6353 / D			130-3720	Digital O/P
V6353 / A / AP		V6353AP	130-3750	Analogue O/P
V6353 / D / AP			130-3720	Digital O/P
V6353Q / A	Quad Demux	V6353Q	130-3750	Analogue O/P
V6353Q / D			130-3720	Digital O/P
V6353Q / A / AP		V6353QAP	130-3750	Analogue O/P
V6353Q / D / AP			130-3720	Digital O/P
V6355 / A	Demux-Mux	V6355	tba	Analogue I/P and O/P
V6355 / D			tba	Digital I/P and O/P
V6355 / AD			tba	Analogue I/P, Digital O/P
V6355 / DA			tba	Analogue I/P, Digital O/P
V6355 / A / AP		V6355AP	tba	Analogue I/P and O/P
V6355 / D / AP			tba	Digital I/P and O/P
V6355 / DA / AP			tba	Analogue I/P, Digital O/P
V6355 / AD / AP			tba	Analogue I/P, Digital O/P

The options above are:

- Q Quad, meaning 4 AES channels (2 Groups, 8 analogue audios)
- /A Analogue audio Input or Output (8 audios)
- /D Digital audio Input or Output (4 AES)
- /AD Analogue I/P with Digital O/P (4 audios, 2 AES)
- /DA Digital I/P with Analogue O/P (2 AES, 4 audios)
- /AP Audio Processing Option enabled.

Note that the V6355 can also operate with the dedicated Input and Output modules which can be either digital or analogue.

2. INSTALLATION

2.1 REAR PANELS

V16VR3R 3U REAR

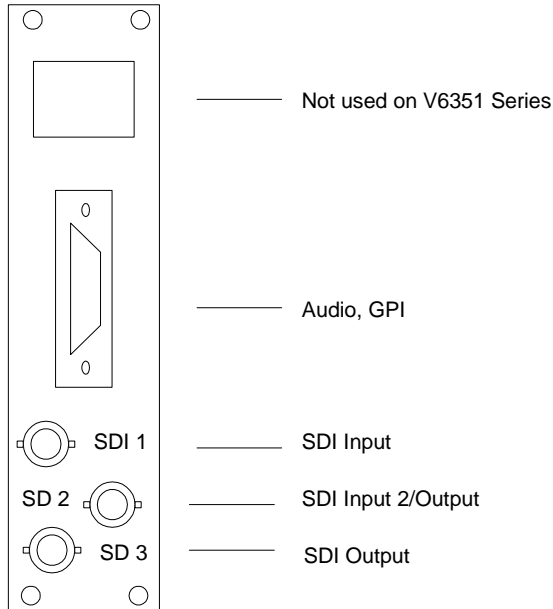

2.2 POWER REQUIREMENTS

These modules are powered from the rack into which they are running and the total consumption depends on which, if any, sub-modules are fitted:

Total Fit	POWER
Main Board alone	6.7 W
Main Board + Digital Input	7.2 W
Main Board + Digital Output	6.8 W
Main Board + Analogue Input	8.0 W
Main Board + Analogue Output	8.6 W

2.3 SIGNAL CONNECTIONS

2.3.1 Video

On all the rear panel types the upper three BNCs are for SDI video as follows:

Connector	Type	Function
SDI 1	BNC	SDI Video I/P
SDI 2	BNC	SDI I/P 2 or O/P 2 (see Note)
SDI 3	BNC	SDI O/P 1
GPI	BNC	GPI Input.

Note: The two options for SDI 2 are by a pair of links on the main PCB (LKs 2 and 3). It is important that both links are set up the same way.

2.3.2 Audio

All audio connections are through the High Density D-type connector (HDD) on the rear panel. For all the modules in the series the audio is always connected to or from the same pins. This table shows all the connections on the HDD connector. For the main audio there are eight blocks of 3 pins – Block 1 to Block 8. These are referred to as Blocks to avoid confusion with groups, channels etc. Each block is either a single analogue balanced differential signal or an AES pair (which, of course, carries two audio signals). The AES pairs may be either differential or single-ended (75R). When working with digital I/O it is likely that either Blocks 1, 3, 5 and 7 or Blocks 2, 4, 6 and 8 would be used depending on the choice of differential or single-ended AES connections.

Internally there are either four AES channels (Quad modules) or just two. These are always used as A, B, C and D, or just A and B for the non-Quad modules. Within each AES there are two audios, often used as Left and Right but indicated here as 1 and 2.

Signal Group	HD44 Pin	Label	Analogue	Digital Balanced	Digital 75R
Block 1	14	Ch A 1 P	Ch A 1 Pos	Ch A Pos	
	44	Ch A 1 N	Ch A 1 Neg	Ch A Neg	
	15	Ch A 1 GND	Ch A 1 Gnd	Ch A Gnd	
Block 2	13	Ch A 2 P	Ch A 2 Pos		Ch A
	43	Ch A 2 N	Ch A 2 Neg		Ch A Ret
	28	Ch A 2 GND	Ch A 2 Gnd		
Block 3	12	Ch B 1 P	Ch B 1 Pos	Ch B Pos	
	42	Ch B 1 N	Ch B 1 Neg	Ch B Neg	
	26	Ch B 1 GND	Ch B 1 Gnd	Ch B Gnd	
Block 4	11	Ch B 2 P	Ch B 2 Pos		Ch B
	41	Ch B 2 N	Ch B 2 Neg		Ch B Ret
	40	Ch B 2 GND	Ch B 2 Gnd		
Block 5	9	Ch C 1 P	Ch C 1 Pos	Ch C Pos	
	39	Ch C 1 N	Ch C 1 Neg	Ch C Neg	
	10	Ch C 1 GND	Ch C 1 Gnd	Ch C Gnd	
Block 6	8	Ch C 2 P	Ch C 2 Pos		Ch C
	38	Ch C 2 N	Ch C 2 Neg		Ch C Ret
	24	Ch C 2 GND	Ch C 2 Gnd		
Block 7	7	Ch D 1 P	Ch D 1 Pos	Ch D Pos	
	37	Ch D 1 N	Ch D 1 Neg	Ch D Neg	
	21	Ch D 1 GND	Ch D 1 Gnd	Ch D Gnd	
Block 8	6	Ch D 2 P	Ch D 2 Pos		Ch D
	36	Ch D 2 N	Ch D 2 Neg		Ch D Ret
	5	Ch D 2 GND	Ch D 2 Gnd		
CVBS A	23	CVBSA*			
	22				
	35	GND			
CVBS B	18	CVBSB*			
	17				
	35	GND			
Misc	20	GPI 1			
	25	GPI 2			
	30	GPI 3			
	27	Reserved			
	29	GND			

* – These connections are reserved for a particular purpose for future developments.

2.3.3 GPI Connections

There are three GPI connections to the V6351 Series. They are through dedicated pins on the HDD connector on the rear panel:

GPI 1	Pin 20
GPI 2	Pin 25
GPI 3	Pin 30

They have internal pull-up resistors of 4K7 Ohms taken up to +5V. They should be made active by grounding the relevant pin.

The status of the GPI pins can be monitored on:

STATUS **GPI Sta** 1↓ 2↓ 3↓

The arrows indicate the status of the GPI input by pointing up if the GPI is active (in practice this means that they point down for +5V and up for 0V).

The GPIs can be used to select a range of features which are described in Section 4.8.1.

2.4 SIGNAL SPECIFICATIONS

SIGNAL	TYPE	COMMENTS
SDI Inputs and Outputs	BNC	SDI Video to SMPTE 259M Max cable length >200m
Audio, Analogue, I/P	HDD 44-way	Balanced, High Impedance, >20kΩ
Audio, Analogue, O/P	HDD 44-way	Balanced, Low impedance, <50Ω
Audio, Digital	HDD 44-way	Balanced - AES3-1992 or Unbalanced - AES3-3id1995
GPI	HDD 44-way	5V pull-up via 4K7 Connect to GND to activate.

2.5 VIDEO INSERTION DELAY

This table shows the insertion delay of the various modules and their configuration:

Product	Delay
V6351	1.62μs
V6351Q	2.18μs
V6353	1.54μs
V6353Q	1.54μs
V6353Q – Split	1.48μs
V6355	1.58μs
V6355 – Split	1.56μs

2.6 ADJUSTMENT RANGES

2.6.1 Video Adjustments

There are no video adjustments.

2.6.2 Audio Gain Ranges

Audio gain adjustments can only be made with the Audio Processing option (AP).

Input gain range :	-16dB to +15.875dB in 0.125dB steps
Output gain range :	-16dB to +15.875dB in 0.125dB steps

These gain adjustments are independent of any setting for the digital levels, known within this document as Maximum Audio Level (MAL).

2.6.3 Audio Input Settings

Audio input settings can only be made with the Audio Processing option (AP).

These operations always operate on each audio pair. In the case of Dual modules there are two pairs, while in the Quad modules there four pairs. The component channels of each pair are referred to as L (for Left) and R (for Right), but they do not need to be related. They could just as easily be referred to as Channels 1 and 2.

The following eight functions are available:

Function	L O/P	R O/P
normal	L	R
L to Both	L	L
R to Both	R	R
LR Swap	R	L
Mono	(L+R)/2	(L+R)/2
L Only	L	mute
R Only	mute	R
Off	mute	mute

2.6.4 Audio Routings

Audio routings can only be made with the Audio Processing option (AP).

These operations allow each output pair to be made up from a combination of the input pairs. This operation happens after the preceding Input Settings. In general there are four input audio pairs that can be routed to the output. But in some cases, for example with a dual Demux (V6353) there may be only two. These are A and B. More likely there will be four contributors.

For 2 channel variants:

A O/P	B O/P	C O/P	D O/P
A	B	A	B
B	A	B	A
A+B	A+B	A+B	A+B
mute	mute	mute	mute

For 4 channel variants:

A O/P	B O/P	C O/P	D O/P
A	B	C	D
B	A	A	A
C	C	B	B
D	D	D	C
A+B	B+A	C+A	D+A
A+C	B+C	C+B	D+B
A+D	B+D	C+D	D+C
A+B+C	B+A+C	C+A+B	D+A+B
A+B+D	B+A+D	C+A+D	D+A+C
A+B+C+D	B+A+C+D	C+A+B+D	D+A+B+C
A+C+D	B+C+D	C+B+D	D+B+C
B+C	A+C	A+B	A+B
B+D	A+D	A+D	A+C
B+C+D	A+C+D	A+B+D	A+B+C
C+D	C+D	B+D	B+C
OFF	OFF	OFF	OFF

2.6.5 Audio Delay

At present the audio delay facility is not available.

2.7 HARDWARE

2.7.1 The PCB

The figure below shows diagrammatically the printed circuit board along with certain other components of interest. In particular it shows the position and orientation of the links and switches which set up the operation modes and the location of the audio sub-module if fitted.

The EPROM location is shown, as it is the component that would need to be changed as a result of any software upgrade in the field. This is a PLCC type and the proper tool should be used to remove a device and care must be taken to ensure that a replacement is inserted the right way round and pushed fully 'home'.

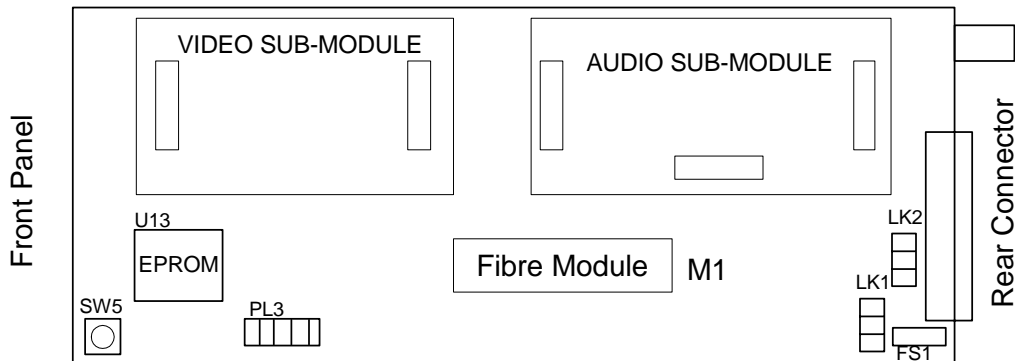

2.7.2 Links and Switches

The purposes of the links and switches is shown in the following table. Details of their operation are described in later sections.

ITEM	Title	Comments
FS 1	Fuse	In series with the +15V input to the module.
SW 5	RESET	Used to reset the internal microcontroller.
PL 3	JTAG Connector	For development and test use only. (May not be fitted)
LK 1, 2	Define BNC 2	North – SDI Input 2 South – SDI Output 2

2.7.3 Fuse

There is only one fuse on these modules which is in series with the main DC input:

FS 1	Fuse 2 Amp Wire ended	In series with the +15V input to the module.
------	-----------------------	--

2.7.4 Audio Sub-module

This provides the audio I/O. These modules can be changed in the field, and the system will automatically detect which type is fitted. Apart from the V6755 Demux-Mux there should always be a sub-module fitted here. It is important that the sub-module is compatible with the main module type. If not, then a banner message will appear on the front panel when the unit is powered.

2.7.5 Video Sub-module

This is never fitted on the V6351 Series.

2.7.6 Fibre Sub-module

This is never fitted on the V6351 Series.

2.8 FRONT PANEL

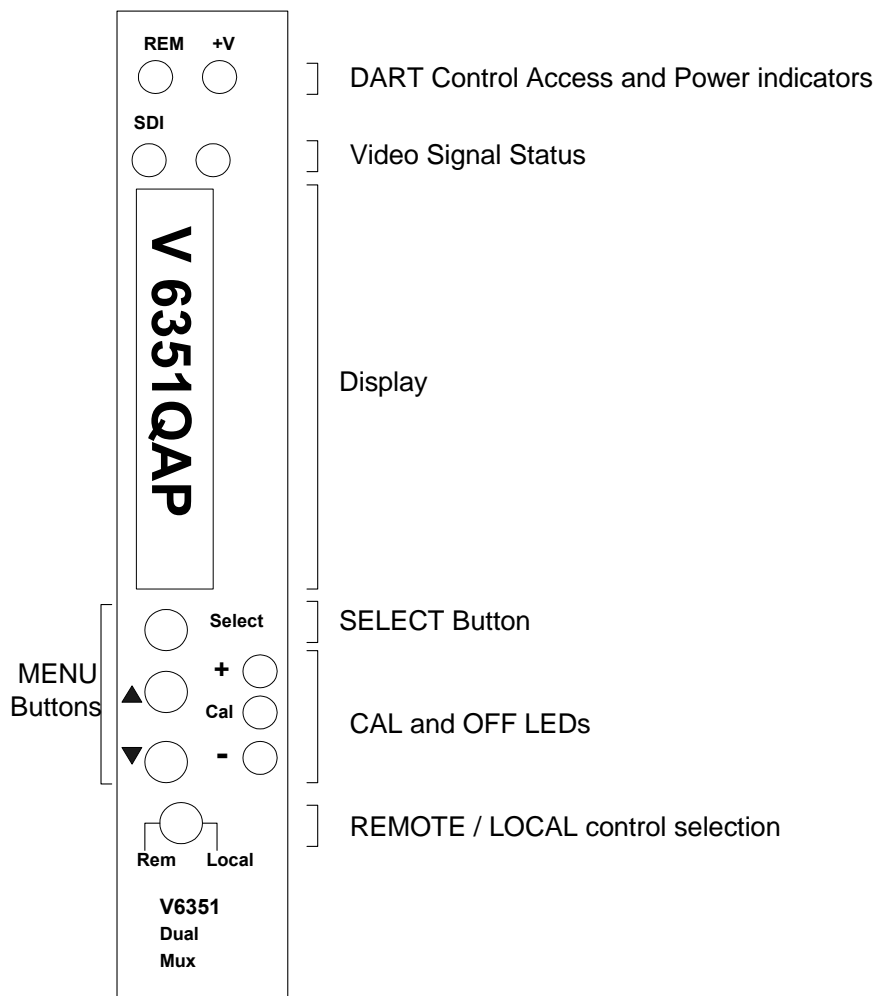

The front panel on the V6351 series is a considerable advance on what is usually available on single module interface equipment. It provides the user with total control and monitoring of the unit without the need to consult manuals and read unlabelled indications. While this kind of control is generally available with a remote control system, as it is over DART, it is unusual to have this level of access locally.

At first use the menu system may seem cumbersome but with only a small amount of practice it will become very easy to use.

2.8.1 Direct Indications

The four LEDs at the top of the panel provide these direct indications of the unit:

- | | |
|-----|--|
| REM | Short blinks to indicate access by the DART controller, if fitted. It does not directly indicate that the unit is in remote control mode. If the rack frame does not have a Rack Controller fitted then this LED will not blink. |
| +V | Indicates that the main regulated power is present on the board. This is derived from the +15V distributed through the rack. The V6351 series has many power rails, but only the main +3.3V is indicated here. It will, of course, be OFF if the fuse, FS1, were to have been blown. |
| SDI | A pair of LEDs to indicate video input signals. The left one shows I/P 1 present. The right one will indicate the presence of I/P 2. I/P 2 may be an SDI, if enabled through LKs 1 and 2 and selected, or a Fibre input if available and selected. |

2.8.2 Display and Switches

The main display is an eight character LED matrix display. It has been set so that when fitted into a 3U rack (V1606) it can be read from the left, and when fitted to a 1U rack (V1601) it is horizontal and the 'proper' way up. (At present there is not a suitable rear module for the V6351 series to be fitted into a 1U frame.)

The three buttons are labelled **Select**, σ and τ . The **Select** button is used to move down and up the menus. A short press will move down one level, while pressing and holding for about half a second will move up one level. If you continue to hold it will progressively move up a level every half second until it reaches the top level (**SLEEP**), or you let go, in which case it will stay where it is. When at any level the σ and τ buttons will move through the list of options, or if in an actual variable (such as Video Gain) they will change the values.

The menu system is described in more detail later in section 4.1.2.

If the unit is in Local control then the display and switches are used to set up and show the operation the module. If in remote mode then they are still active for showing the status but cannot be used to actually change anything.

Beside the σ and τ buttons are three LEDs marked **+CAL** and **-**. In general the **CAL** LED is used to show that a variable is set to its normalised value and if not then the others show which direction to which it has been changed or that it is no longer on its CAL value.

2.8.3 Remote/Local Control

The lowest switch selects between Local control and Remote control over DART:

Local	Control is from the front panel itself.
Rem	Control is from the DART system. This requires the use of an external controller running a suitable programme, which communicates with multiple racks using the Dartnet protocol.

3. BLOCK DIAGRAMS

3.1 GENERAL

All the modules within the series are similar but there are subtle differences, particularly with the way audio is routed, and how blanking is applied to the video. The block diagrams in this section will help with the understanding of how the various parts are connected in terms of video and audio.

The FIFO section is for re-timing the inputs, so that they operate with a clean regenerated clock.

The audio Processing section is shown on all these block diagrams but it will only be available with the AP option. If the AP option is not available then the A, B, C, D outputs will be connected directly from the A, B, C, D inputs respectively.

The SEL block is a selector for choosing the video input to be from either SDI 1 or SDI 2. SDI 2 is only available if the Links LK 1 and 2 are set to North.

The delay function, when it becomes available, will be an adjunct to the Audio Proc function.

The OP block ensures a legal output, and puts EDH error checking codes on the output.

The Blanker block, which can be disabled, removes all ancillary data from the SDI video. Note that this also includes any non-audio type embedded data.

3.2 V6351 DUAL MULTIPLEXER

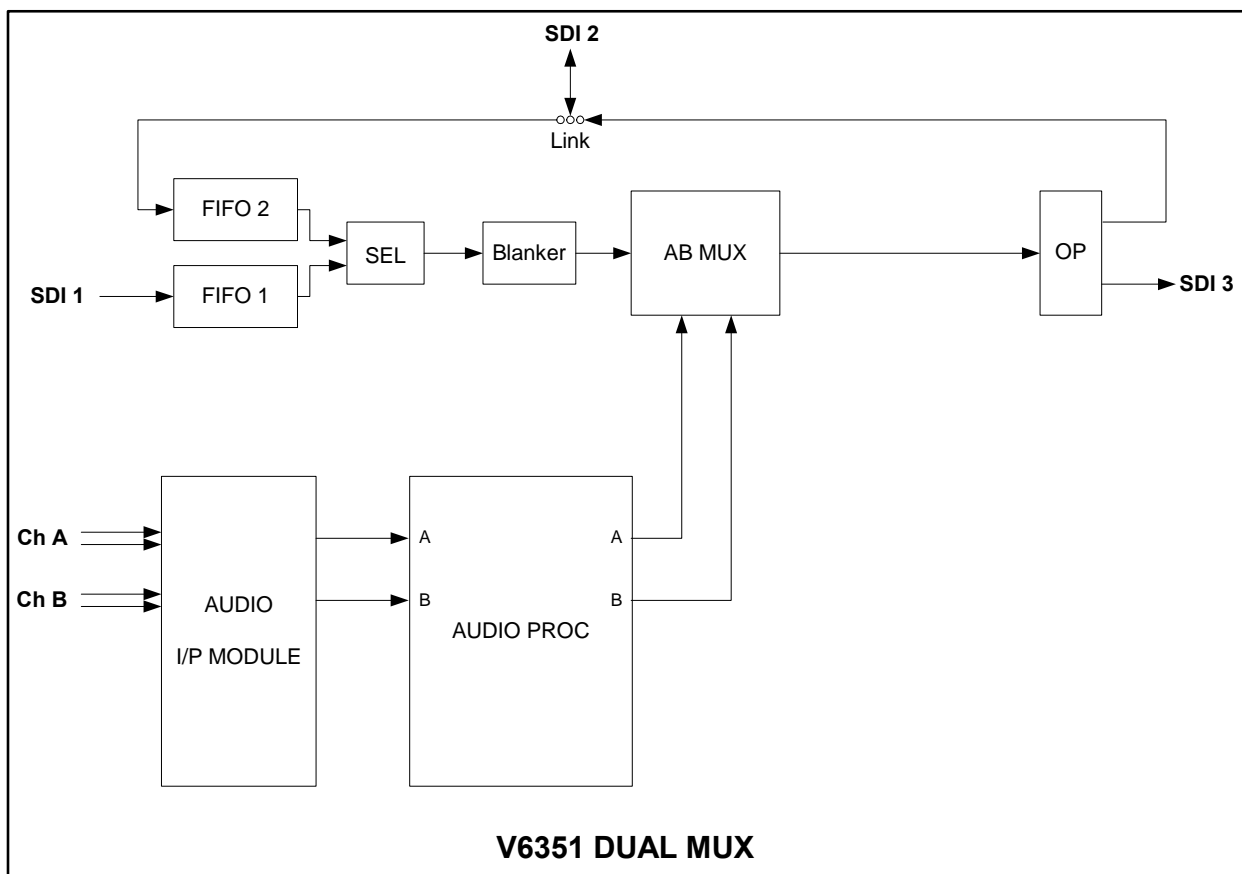

3.3 V6351Q QUAD MULTIPLEXER

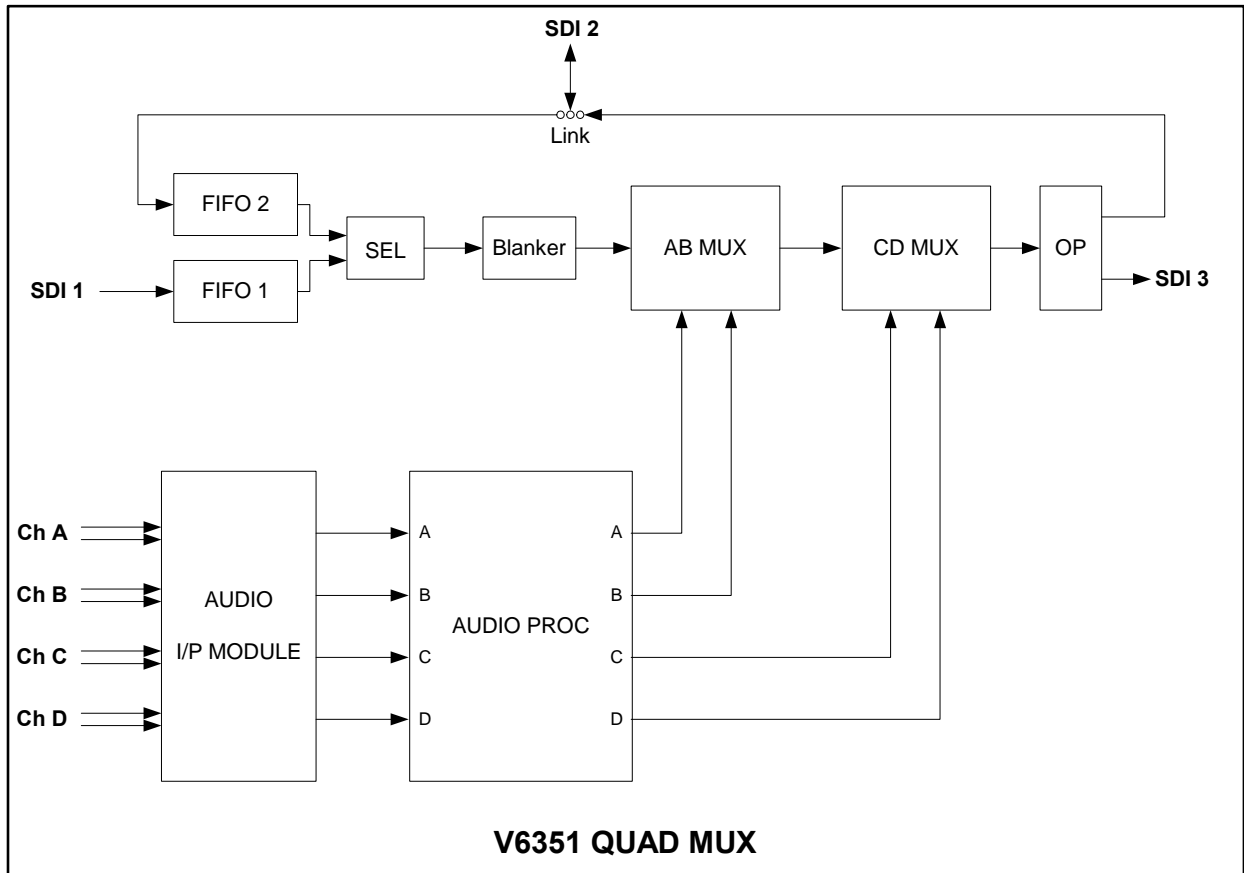

3.4 V6353 DUAL DEMULTIPLEXER

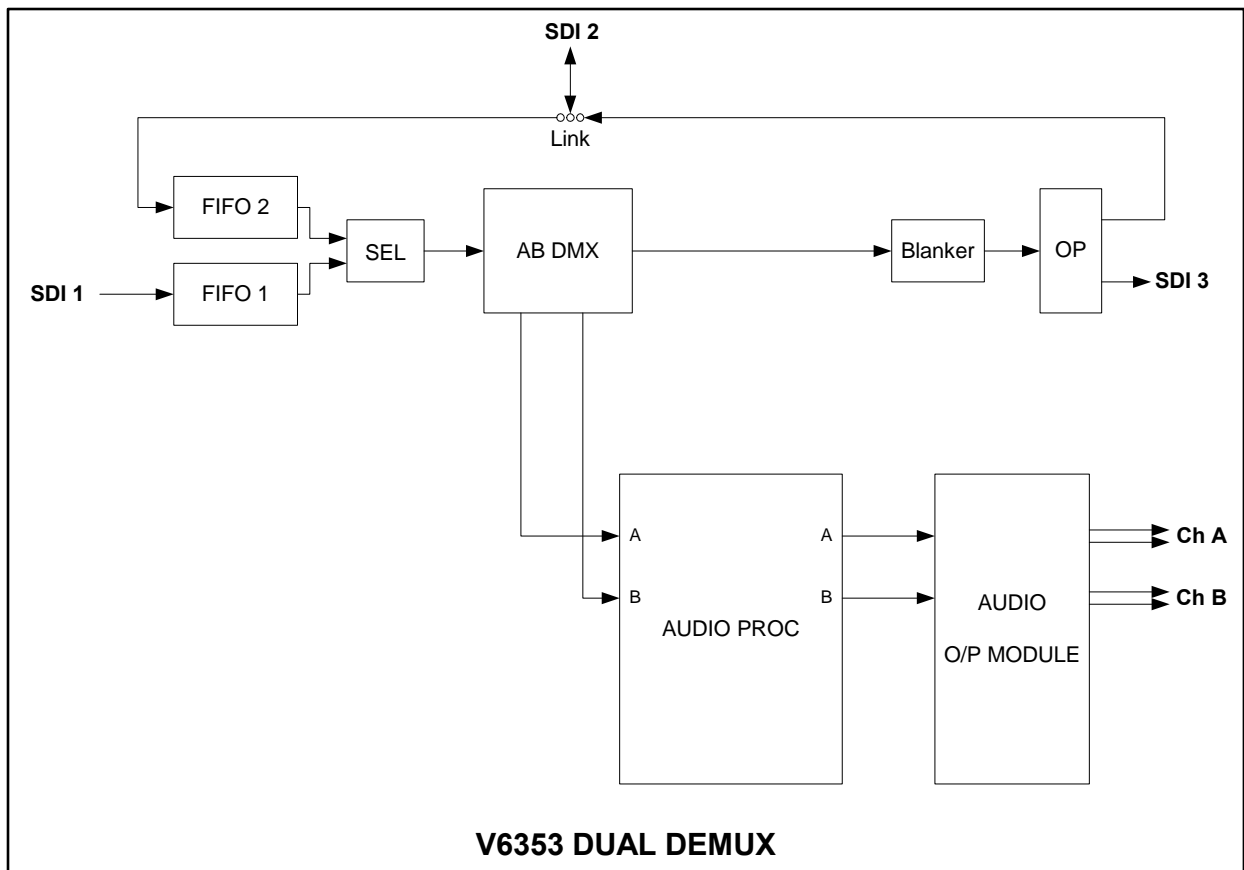

3.5 V6353Q QUAD DEMULTIPLEXER

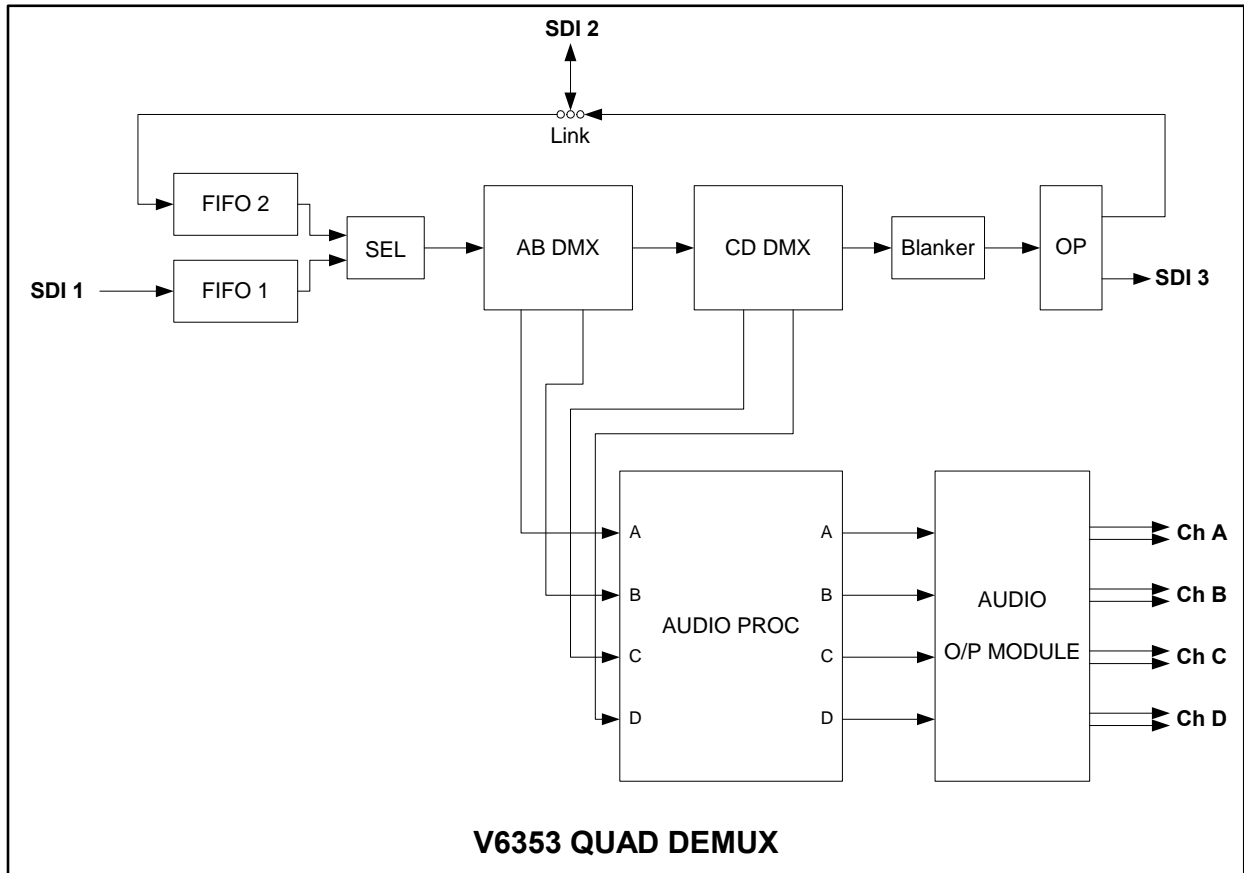

3.6 V6353Q QUAD DEMULTIPLEXER – SPLIT MODE

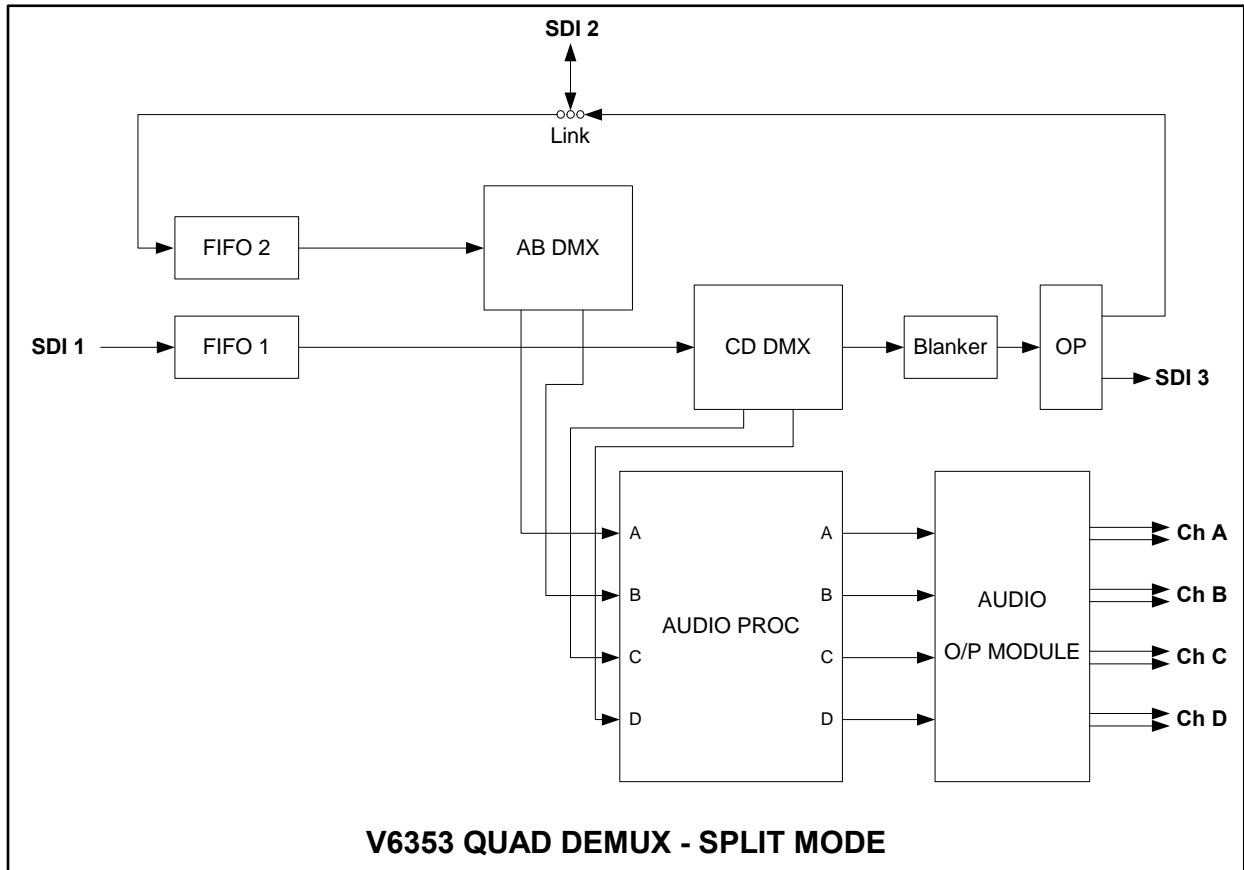

3.7 V6355 DEMULTIPLEXER - MULTIPLEXER

This module is more complex than the others in the way audio is routed and processed. In the main this is because a variety of audio I/O modules can be fitted. In fact because it can both demux and mux it can operate quite happily with no module at all. In this way it can be used to shuffle or edit from one group and then re-embed on another or, indeed, back onto the same group again.

If an I/P type audio module is fitted then the audio processing works on a mixture of the extracted audio and the external input. The external input audio should always be connected to the C and D inputs (this only applies to the V6355).

If an O/P type module is fitted then the processing can only work on the extracted audio. The external output is always on the A and B outputs and is a copy of the audio being multiplexed on the C and D channels.

If an I/O type module is fitted then there is both a external inputs and external outputs. The inputs should always go on the C and D channels and the outputs will be on the A and B channels. However even within this arrangement there are two ways of operating with an I/O module:

1. Track – The A,B outputs are a direct copy of the C and D audio being multiplexed onto the video.
2. AudioSplit – The A,B outputs are derived from the A and B audio being demultiplexed.

Which way to operate depends on the application. For example if the V6355 is being used around a VT machine to provide it with an effective embedded audio capability then the split mode should be used. However if it is being used to provide a dual service of embedded audio along with a separate analogue or digital feed then the Track mode should be used.

3.7.1 DMX – MUX, no Audio Module

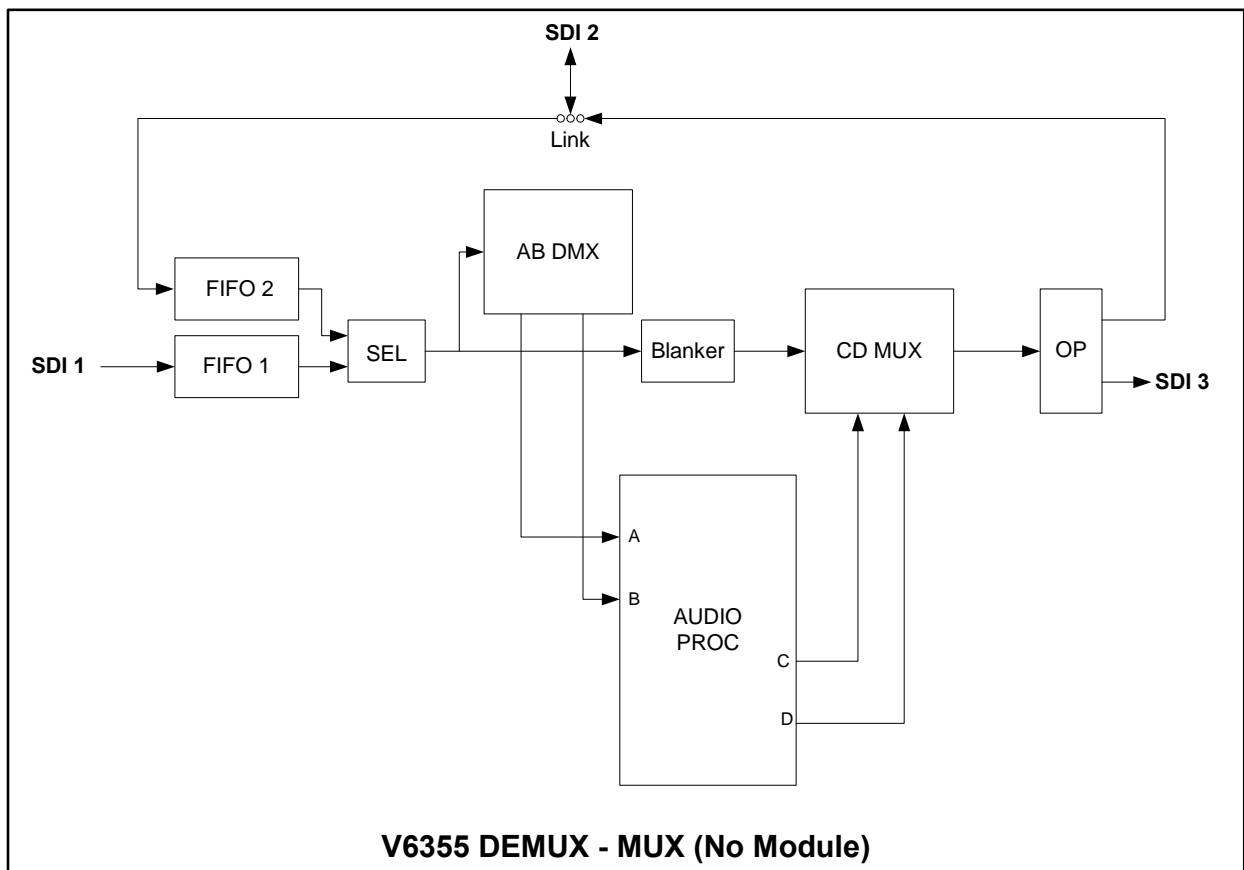

3.7.2 DMX – MUX, I/P Audio Module

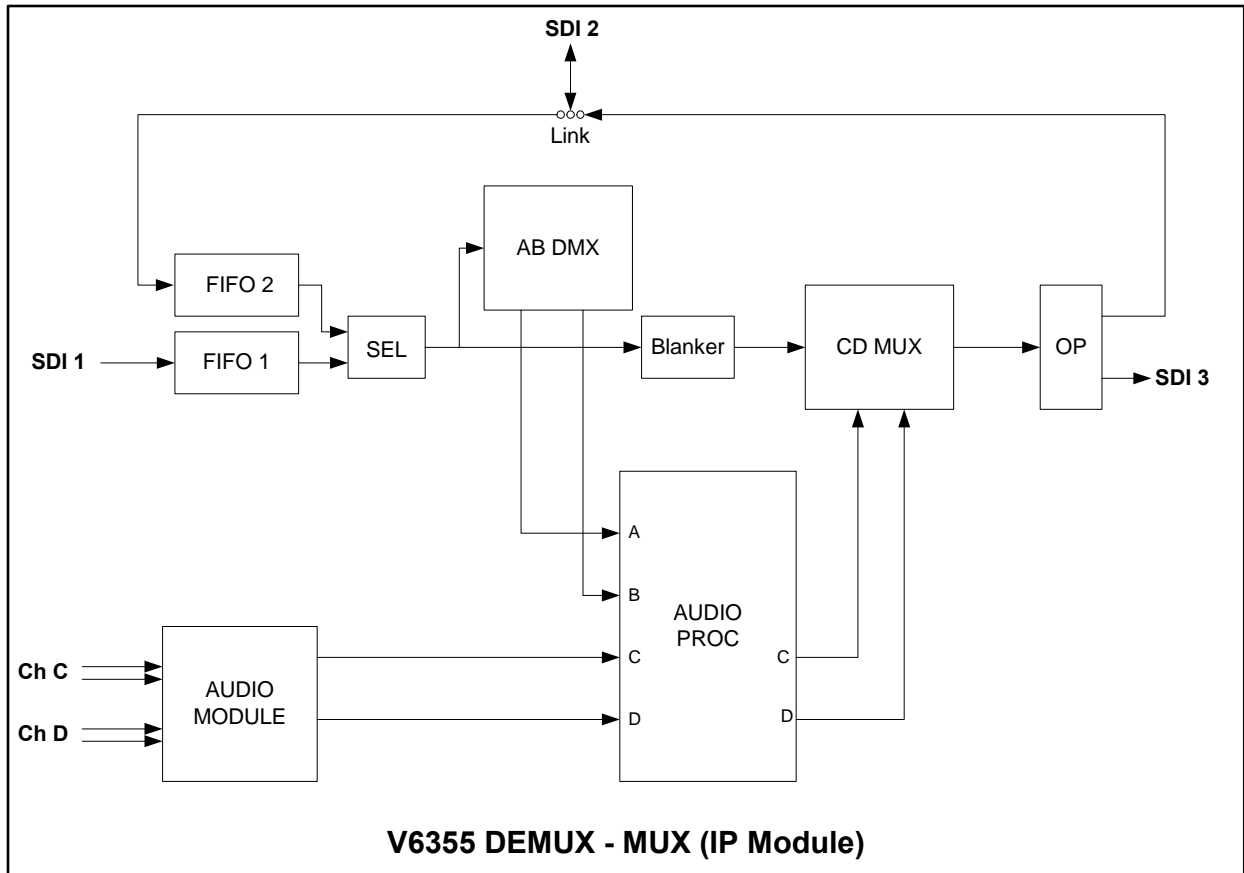

3.7.3 DMX – MUX, O/P Audio Module

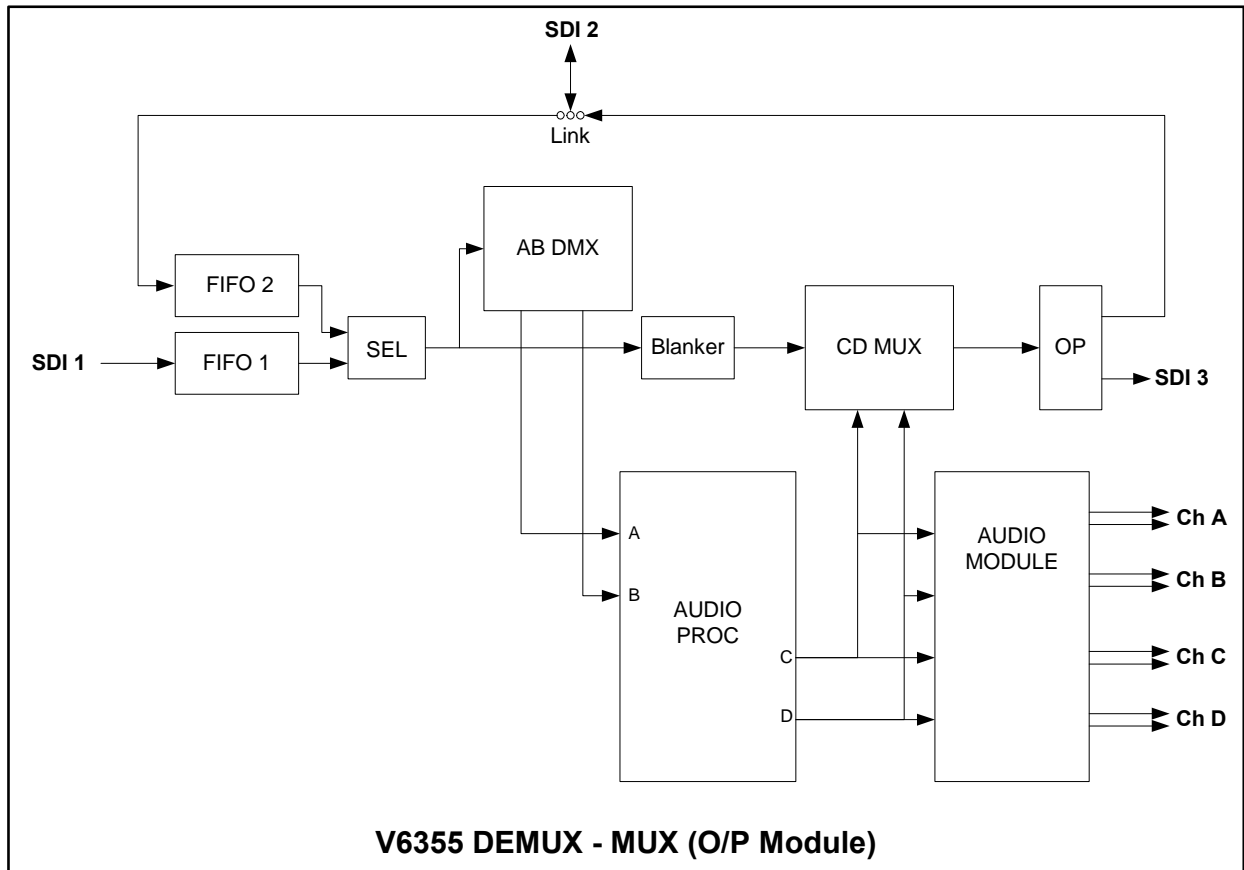

3.7.4 DMX – MUX, I/O Audio Module (Track Mode)

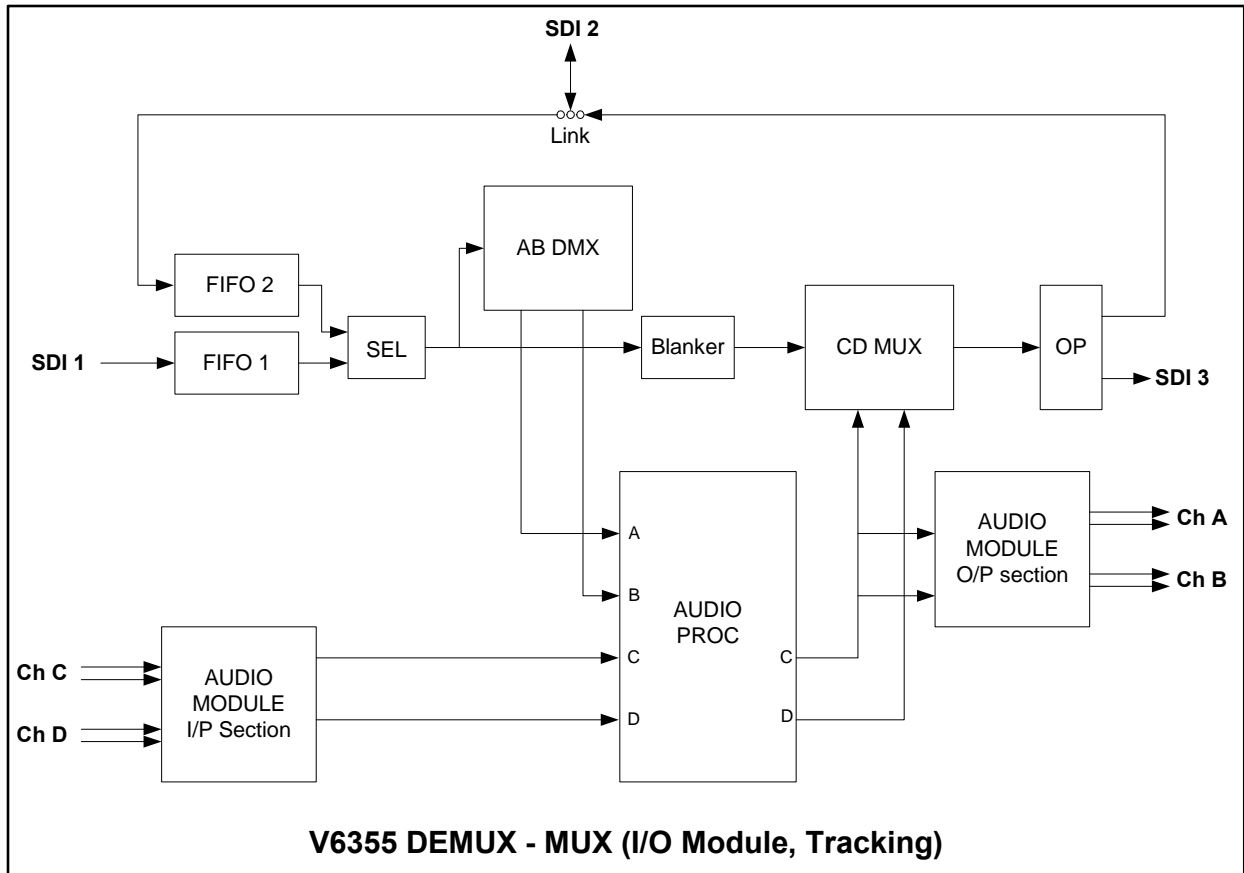

3.7.5 DMX – MUX, I/O Audio Module (Audio Split Mode)

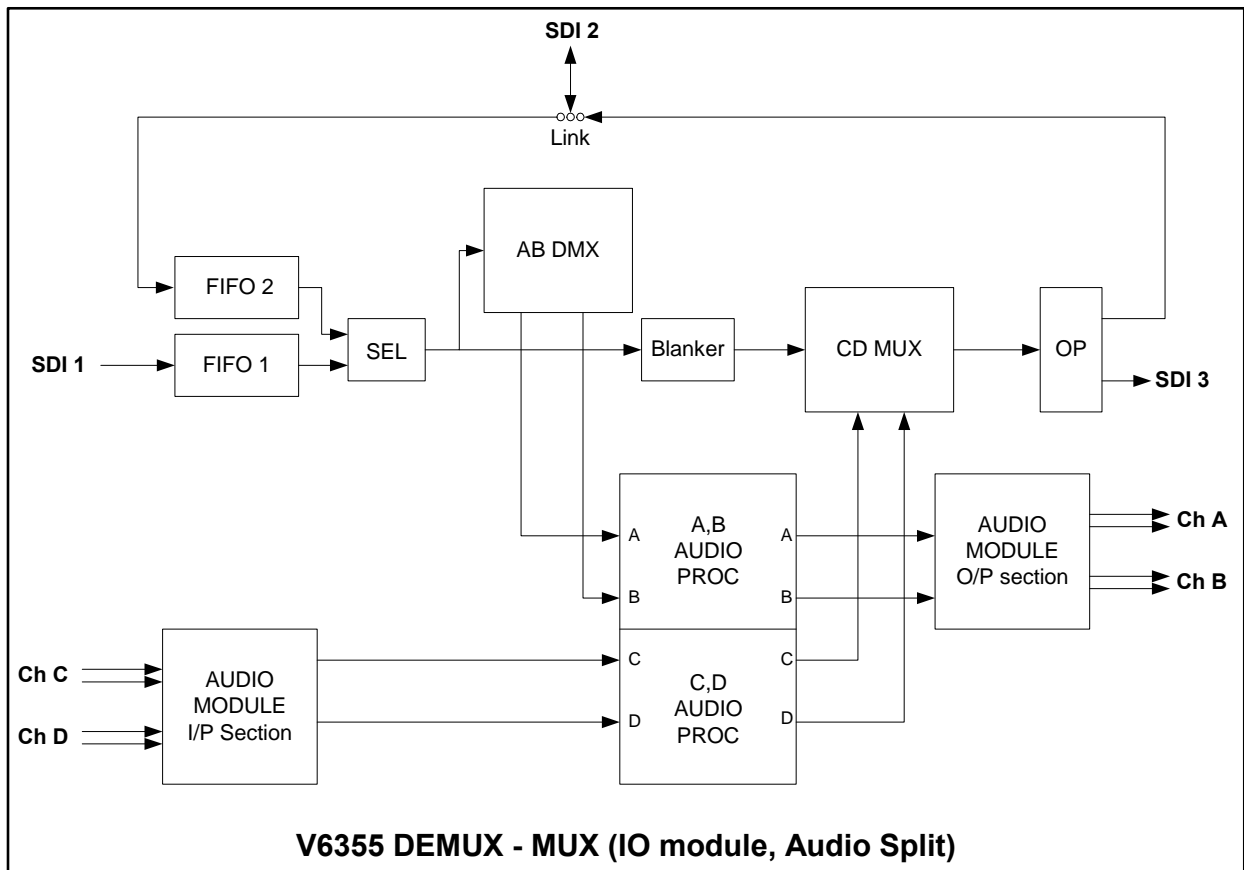

3.8 AUDIO PROCESSING

This block diagram shows the general flow of the audio processing when enabled. It shows all four channels, A, B, C and D which are available with the Quad modules. The Dual modules generally have access to only the A and B channels.

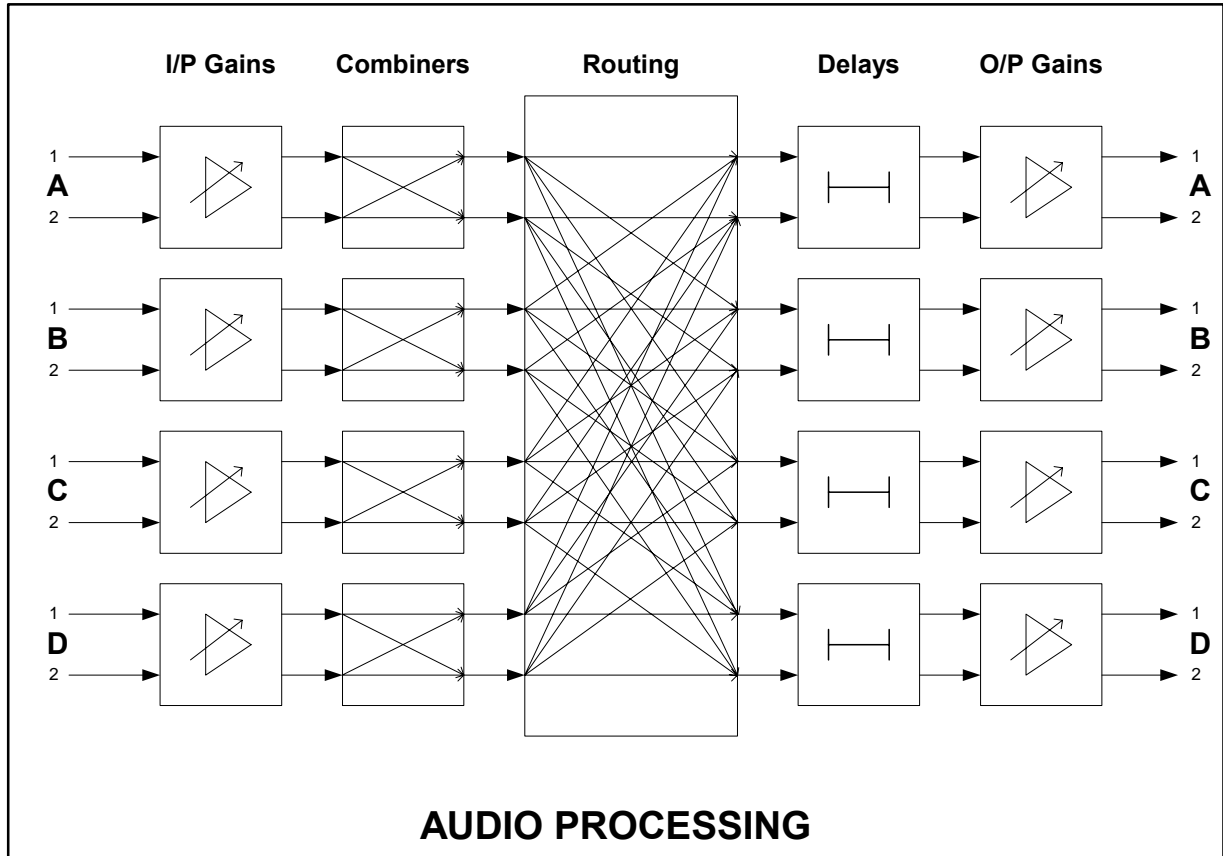

At present the Delay operation is not yet available.

4. SYSTEM OPERATION

4.1 FRONT PANEL

4.1.1 Start up

Local control and monitoring of the V6351 Series is done through the front panel with its eight character LED display and three control buttons **Select**, σ and τ . There are three LEDs which also contribute to the status indication; these are labelled **+**, **Cal** and **-**.

After power up the display will start at the top level and show the unit type and any options that are included. These options are not the same as the plug-on modules for the audio I/O. The display will be one of these:

v6351Q Indicating a V6351 Quad Mux, without the Audio Processing option

4.1.2 Menu Control

The **Select** and σ and τ buttons are used to manoeuvre around the menu system. The menu structure has five levels and the **Select** button is used to go up and down the structure. The σ and τ buttons are used to move between selections or to adjust a parameter depending on which sort of menu is displayed. The five levels are as follows:

Sleep	Display is blank (except for Banner warnings).
Top Level	As above, e.g. v6351
Main Menu	The Main menu items, such as MAIN , AUDIO , ENG' ING etc. These items are all in Upper Case.
Sub Menu	Menu items under each main heading, such as Video or A IPGain under the MAIN and AUDIO main menu. These items are all in Sentence Case (generally lower case but with upper case first letters).
Parameter	The lowest level under the Sub Menu, and used to actually adjust a parameter. The display will depend on the actual parameter and may be a value such as +0.00dB for a gain or ON or OFF for a switch variable. There is usually a title to describe the variable and a small icon in the left hand character position, but 8 characters cannot provide for a detailed description.

Many of the sub menus depend on which audio I/O sub modules are fitted. For example the Calibration functions of the analogue audio ADCs and DACs under **CALIB** do not appear unless a suitable sub-module is fitted.

To move down a level just press the **Select** button briefly; then press either the **Select** button again to go down another level or the σ and τ buttons to move around the options within a level.

To move up a level press and hold the **Select** button for about half a second which will move up one level. If you continue to hold the **Select** button then it will move up a level every half a second until it reaches the Sleep level (one above the Top Level).

A complete list of all the menus is given in Section 7.

4.1.3 Menu Examples

This section has examples of how to manoeuvre through the menu system. The first one starts with the unit in its 'sleep' mode where the display is blank, and then proceeds to set the CD channel to multiplex onto Group 2 (assuming a V6351Q).

Action	Display	Comments
Select	V6351	Top Level
Select	MAIN	First Main Menu, and the one we want
Select	Video	First sub-Menu, and the one we want
▼	AB MuxGp	
▼	CD MuxGp	
Select	CD Gp -	The default setting – no muxing.
σ	CD Gp 1	
σ	CD Gp 2	Set it as we want it.

Now we shall select The ancillary blanking to be OFF. The following steps should be taken from the current position (Select+Hold means that you should press and hold the select button for about half a second):

Action	Display	Comments
Select+Hold	CD MuxGp	UP to the Sub Menu level
Select+Hold	MAIN	UP again to the Main Menu
▼	AUDIO	Assuming the AP option is enabled
▼	DELAY	Assuming the AP option is enabled
▼	STATUS	
▼	ENG' ING	Along to the Engineering Main Menu
Select	Ref Src	
▼	Format	
▼	Anc Data	To the Sub Menu we want
Select	Anc Blnk	This is the default setting.
σ	Anc Pass	As we want it

4.1.4 Sleep

If the front panel is not used for a certain amount of time then the display will automatically go into a sleep mode when it will be blank. Pressing any of the buttons will cause it to 'wake up' back into the top level. The time delay before the unit slips into sleep mode can be set up using the **ENG' ING : Sleep** menu.

4.1.5 Brightness

The brightness of the display can also be adjusted using the **ENG' ING : LEDLevel1** menu.

4.1.6 Banner

There are some conditions which need to be directly indicated to the operator and although the display system is highly versatile for a lot of complex operations it is not really convenient for immediate indications. In the past LEDs on the front panel have been used for this purpose.

To help with this a banner message will pass across the screen from right to left to show any critical statuses when the display is in sleep mode. This saves the need to manoeuvre down the menus to find out, for example, that a Test Pattern has been selected. Remember it is not necessary to wait for the time-out period for the unit to go into sleep mode, it can be forced there by going up a level from the so-called Top Level. The following conditions will be displayed on the Banner:

No Audio Module Fitted...	No audio module is fitted, but one is required. The only exception is the V6355 Demux/Mux
Incompatible audio Module...	Either an I/P module has been fitted to a V6353 or an O/P module to a V6351.
AB Mux Error	The AB Mux is using a Group that already exists. This is a serious problem. Either use a different group or make sure that ancillary blanking is ON.
CD Mux Error	The CD Mux is using a Group that already exists. This is a serious problem. Either use a different group or make sure that ancillary blanking is ON.
Wrong audio module for Split Mode...	Only applies to the V6355, where you must have an Input/Output type module for split mode. Either change the audio sub-module or go to Normal mode

The banner can be switched off in the the **CONFIG : Banner** menu.

4.1.7 High Level Signal Status

There are two LEDs on the top of the front panel to indicate that the SDI inputs are present, and consequently these also indicate that they are absent. However there is no direct indication as to the format of these signals, i.e. 625/50 or 525/60. Since many installations may use multiple formats and therefore need a quick indication there are parallel menus with the Top Level.

If you press the σ and τ buttons from the Top Level then you will see the SDI and audio status directly. In each case this will show the signal presence and if it is there then what format it is. Again this is considerably faster than manoeuvring down the menu structure. For example:

SDI 6254

There are in fact three different stati available at this level. They are:

IP 625 4	or	IP FAIL	
AES AxBx	or	AES A4B4	
AES CxDx	or	AES C4D4	Depends on actual configuration and audio sub-module.

These indications are still at the Top Level along with the indication of type of module, so a single press of the Select button will immediately move down the menu tree to a Main Level.

4.1.8 Variable Calibration

Most variables have a calibrated or normalised value. In some cases this is obvious, such as a gain setting should be normalised to 0dB, but in others it is less so. In the listing of all the variables in Section 8 the normalised value, if applicable, is shown.

Any variable can be individually set to its normalised value by pressing the σ and τ buttons at the same time.

Within each the Main Menu at the end of the list of Sub Menus is a pseudo Sub Menu called **Norm**. Selecting into this will let you normalise all the parameters within the Main Menu item to their normalised value.

The three LEDs beside the σ and τ buttons are used to show whether the variable is calibrated or not. After calibration the **CAL** LED will be ON.

4.2 REMOTE CONTROL

In addition to being controlled with the menu system on the front panel the V6355 Series can also be controlled over the DART remote control system. For this it should be fitted into a rack which also contains a Rack Controller. The Rack Controller provides an interface between all the units in the rack and the external DARTNET network. Various controlling devices are available for accessing units on the DARTNET; these include the V1602/V1605 1U and 2U hardware panels, the ViewFind PC program and the more sophisticated ViewNet Client Server interface. It is also possible to have third party software written to interact with DARTNET. The details and specification of the DART interface are described elsewhere.

There are separate settings for the unit when operating in Local and Remote control modes. This means that if the unit is changed between Local and Remote mode then the settings may change. The advantage of this is that if the unit has been set up locally and the operator inadvertently changes to Remote mode (which probably has different, or even default, settings) the local settings are not lost. There could be a disadvantage in that once the unit has been set up remotely it cannot not be switched to Local without causing a disturbance.

When in Remote Control the front panel menu system is still active but is only used to monitor the status of the unit. It cannot be used to change anything. There are in fact some exceptions to this since some parameters cannot be controlled remotely. For these, which are listed below, it is always possible to use the front panel to change them.

ENG' ING	O/P EDH	Disable/enable EDH on the output
ENG' ING	Sleep	Set the display Sleep timeout
ENG' ING	LEDLevel	Set the Display brightness
CONFIG	Banner	Turn the top level display Banner On or Off
CONFIG	GPI 1	Set the application for GPI 1
CONFIG	GPI 2	Set the application for GPI 2
CONFIG	GPI 3	Set the application for GPI 3

4.3 VIDEO PROCESSING

4.3.1 SDI Input

The input SDI signal should be connected to the BNC labelled SDI 1. A second SDI signal may be connected to SDI 2 provided Links LK 1 and 2 are set correctly. SDI 2 may then be selected either from the front panel, over the DART remote control or by using one of the GPIs. These are all described elsewhere. Note that if the links are set for a second SDI input then only one output is available.

If the input fails then the units will continue to operate with their own internal oscillator. While this has little use for the demultiplexers, it does mean that the multiplexers will continue to operate and embed audio. If or when the SDI input returns then the unit will return to using the video. Note that these transitions to operation with and without an SDI input are not clean and glitch free.

4.3.2 Reference and Locking

There is no external reference to these modules. Normally they derive all timing information from the selected input video, but it is possible to force them to use the primary AES input and ignore the video input. The AES on the A input is always used for the AES reference. In this case the video output will

be black. This could be used to ensure that the video output is always locked to the primary AES. They can also be forced into a free-run mode where no reference is used. These settings are made here:

ENG' ING Ref Src Auto, AES or Free Run

For the vast majority of situations this should be left in **Auto**.

4.3.3 Split Mode

The V6353Q and the V6355 can be operated in a Split Mode. In this mode it is essential that Links LK 1 and 2 are set to allow SDI 2. The SDI 1 input feeds the AB Demux section and the SDI 2 input feeds the CD section. (The CD section will be either a Demux, for the V6353Q, or a Mux for the V6355).

The two SDI videos must be synchronous and closely timed. This means they must be derived from the same clock and be timed to within ± 16 samples (0.5 μ s).

The block diagram in section 3.6 shows how the SDI inputs are used on the V6353Q. Although there is no Block Diagram the V6355 uses the SDI videos in the same way.

4.3.4 Standard Detection

The modules automatically detect the format of the selected input signal, 625/50 or 525/60, and normally operate accordingly. If the input fails then they will continue to operate in the previously detected format.

It is possible to force operation in one of the two formats independently from the input format.

ENG' ING Format Fmt Auto
Fmt S625
Fmt S525

4.3.5 Ancillary Blanking

The ancillary data area can be blanked on the selected SDI signal. The blanking takes place in a different place depending on the type of module.

It is not possible to selectively blank different types of ancillary data – either all is passed or all is blanked. Therefore there is no point in blanking the data at the front end of a Demultiplexer, since this would remove the data to be demultiplexed. The blanking is applied as follows:

V6351 Mux	Input
V6353 Demux	Output
V6355 Demux - Mux	Input of Mux part.

The Block Diagrams in Section 3 show this process in more detail.

4.3.6 Vertical Interval

The vertical interval of the SDI signal is always passed. There is no separate processing of the vertical interval any differently to the active picture.

4.3.7 TRS Signals

The digital TRS signals (Timing Reference Signal) are regenerated by the modules. This means that any minor errors on the input will be corrected.

The output TRS signal is always 10 bit compatible.

4.3.8 EDH

The EDH data is usually regenerated on the output. This is particularly important on the multiplexers since the data will have changed. It is possible, on the Engineering menu to disable the EDH generation.

Note that if the ancillary data is not being blanked (either before or after the embedding operation) then any existing EDH data will pass through to the video output processing section. This means that if the

EDH generation is turned off then the existing EDH data will probably be incompatible with the video data. This may cause an error to be indicated on following equipment.

4.3.9 Illegal Codes

Apart from the regeneration of the TRS and EDH data no processing is done to detect or remove illegal codes within the video.

4.4 AUDIO GROUPS

Audio is embedded into a digital video signal by occupying the horizontal blanking interval. Within the analogue world this is where the sync pulse and burst would appear. These are not required for digital signals because an embedded Timing Reference Signal (TRS) is used at the start and end of the active video. The TRS is a short burst of data which defines the pixels, lines and fields.

The horizontal interval is slightly different for the 525/60 and 625/50 formats. 525/60 has 268 samples at 27MHz, while 625/50 has 280.

This horizontal blanking is available on every line in the signal, not just the active part, and can be used for lots of data, not just audio.

Most broadcast audio is sampled at 48kHz to a resolution of at least 20 bits. Other sample rates are sometimes used, but are usually converted to 48kHz before embedding. This is what the V6351 series does. The audio is also usually grouped into pairs. These may be separate language services, or stereo pairs, but are usually routed and processed together.

The most common way of carrying digital audio is as an AES signal. This contains a pair of audio signals each with a word width up to 24 bits and associated channel status data. It is this signal which is embedded into the video signal.

Audio is embedded into any one of four groups, known as Group 1 to Group 4. Each group carries two AES signal (i.e. four audio signals). All groups can be embedded but there can be only one embedding of each group. Thus if a signal already contains a Group 1 then you cannot embed another Group 1 without removing the first one.

With the audio data rate at 48kHz and the video line rate at 15.625kHz (for 625/50 format) there needs to be, on average, 3.072 samples added to each line. This means that most lines have 3 samples while some need 4. (In fact the specification requires some lines to not have any data at all, so there are more '4 sample lines' than may be expected.) Each AES signal occupies 6 video samples (because the video samples are 10 bits wide while the audio with its data is about 27) so a '4 sample line' with two AES signals will need 48 samples. Four groups then require at least 192 samples.

This is a simplification, by not including some overheads, and does NOT allow for extended audio up to 24 bits. When all this is included then it can be shown that four full resolution groups can be fitted into a 625/50 signal, but may be truncated when fitted into a 525/60 signal. As a general rule four groups of full resolution data should not be used on 525/60 signals. If the signals being transmitted are only 20bits wide then there is no problem with four groups in 525/60 systems.

All the groups, and any other ancillary data, must be concatenated. There should not be any gaps so it is easy for subsequent equipment to add more data. It is not generally possible to remove any particular block of data, only to wipe the whole area clean.

Despite a detailed standard there are several variants as to how embedded audio is related to the video in terms of sampling frequency. Much equipment requires the two sampling frequencies for video and audio to be synchronous to one another. While they are clearly different values, 27MHz and 48kHz, to be synchronous they should have a common generating frequency such that there are an exact number of audio samples for each video frame(s):

625/50	1920 samples per frame
525/60	8008 samples per 5 frames

When an analogue audio signal is being used it is a simple matter to ensure that the ADC sampling frequency is locked to the video, but this is harder with a digital input. On the V6351 series the Digital input module has high quality re-sampling filters which ensure that the embedded audio is synchronous.

4.5 AUDIO MULTIPLEXING

The audio can be embedded into any one of the four available groups. It is not possible to embed onto an already existing group unless the video signal has its ancillary data blanked. This can be done in the module.

To blank the incoming ancillary data go to:

ENG' ING	Anc Data	Anc Blnk	Ancillary blanked – default condition
		Anc Pass	Ancillary passed

There is nothing to actually stop you embedding onto an existing group, but there is a banner on the top level to indicate the error. It is possible to see what is on the incoming video on the status menu as below:

STATUS	I/P Grps	None	Indicate no audio
		1 2 3 4	Indicate the channels that are present. A small 'E' will indicate if they are extended to 24 bits.

The dual version, V6351, can only embed one group, referred to as the AB Group.

MAIN	AB MUXGp	AB Gp -	No Group – Default
		AB Gp 1	Group 1
		AB Gp 2	Group 2
		AB Gp 3	Group 3
		AB Gp 4	Group 4

The demux/mux, V6355, can also only embed one group, but in this case it is referred to as the CD Group, since the AB is used to demultiplex.

MAIN	CD MUXGp	CD Gp -	No Group – Default
		CD Gp 1	Group 1
		CD Gp 2	Group 2
		CD Gp 3	Group 3
		CD Gp 4	Group 4

The Quad module, V6351Q, can embed onto all four groups

MAIN	AB MUXGp	AB Gp -	No Group – Default
		AB Gp 1	Group 1
		AB Gp 2	Group 2
		AB Gp 3	Group 3
		AB Gp 4	Group 4

MAIN	CD MUXGp	CD Gp -	No Group – Default
		CD Gp 1	Group 1
		CD Gp 2	Group 2
		CD Gp 3	Group 3
		CD Gp 4	Group 4

4.6 AUDIO DEMULTIPLEXING

Audio can be extracted from any of the four groups. The dual unit, V6353, can extract from one group, while the quad, V6353Q, can extract from two groups. They can both be set to the same group. There is no problem with multiple groups on demultiplexing, but it is possible to remove all the ancillary data from the output video. This is done after the de-embedding so does not affect the audio. If a groups has been multiplexed more than once onto the video, then the demultiplexer will not recognise this, but produce bad output audio.

To blank ancillary data on the video output go to:

ENG' ING	Anc Data	Anc Blnk	Ancillary blanked – default condition
		Anc Pass	Ancillary passed

It is possible to see which if any of the groups on the input are occupied:

STATUS	I/P Grps	None	Indicate no audio
		1 2 3 4	Indicate the channels that are present. A small 'E' will indicate if they are extended to 24 bits.

The dual demux version, V6353, can only de-embed from one group, referred to as the AB Group.

MAIN	AB DMXGp	AB Gp 1	Group 1
		AB Gp 2	Group 2
		AB Gp 3	Group 3
		AB Gp 4	Group 4

The demux/mux, V6355, can also only embed one group, but in this case it is referred to as the CD Group, since the AB is used to demultiplex.

MAIN	CD DMXGp	CD Gp 1	Group 1
		CD Gp 2	Group 2
		CD Gp 3	Group 3
		CD Gp 4	Group 4

The Quad module, V6353Q, can de-embed from all four groups

MAIN	AB DMXGp	AB Gp 1	Group 1
		AB Gp 2	Group 2
		AB Gp 3	Group 3
		AB Gp 4	Group 4
MAIN	CD DMXGp	CD Gp 1	Group 1
		CD Gp 2	Group 2
		CD Gp 3	Group 3
		CD Gp 4	Group 4

4.7 AUDIO PROCESSING

The Block diagram in section 3.8 will help explain the flow of audio processing.

4.7.1 Input Processing

The input processing is only available with the Audio Processing option (AP). It allows for setting the gains of each input channel and set-ups within each pair.

For gains go to:

AUDIO	A IPGain
	B IPGain
	C IPGain
	D IPGain

All gains are adjustable from -16.00dB to +15.875dB in 0.125dB steps. The default setting is 0dB.

Each channel pair can be set up in various ways. It is not possible at this stage to move signals from one pair to another but a full facility is allowed within each pair. Go to:

AUDIO	A Setup	A Normal	
		A L Both	Channel 1 to both Channels 1 and 2
		A R Both	Channel 2 to both Channels 1 and 2
		A LR Swap	
		A Mono	
		A L Only	Channel 2 to mute
		A R Only	Channel 1 to mute
		A Off	Both channels to mute

The other four channels, B, C and D, are similar.

4.7.2 Routing

The routing section is only available with the Audio Processing option (AP).

The routing section allows for different selection and combinations to be applied to each output pair. Again it works with the A, B, C and D pairs (the dual units only have access to the A and B channels). There are sixteen different combinations for each which allows for all permutations and combinations. On the front panel the order of the selections may be different for each channel, so that the default is always first, but all combinations are available.

AUDIO	A O/P	A	A
		A	B
		A	C
		A	D
		A	A+B
		A	A+C
		A	A+D
		A	A+B+C
		A	A+B+D
		A	A+B+C+D
		A	A+C+D
		A	B+C
		A	B+D
		A	B+C+D
		A	C+D
		A	OFF

Channels B, C and D are similar.

The dual unit, V6353, only has A and B outputs so the selection is a bit less versatile:

AUDIO	A O/P	A	A
		A	B
		A	A+B
		A	OFF

4.7.3 Delays

At present the audio delay facility is not available.

4.7.4 Output Processing

The output processing is only available with the Audio Processing option (AP).

It allows for setting the gains of each output channel.

For gains go to:

AUDIO	A OPGain
	B OPGain
	C OPGain
	D OPGain

All gains are adjustable from -16.00dB to $+15.875\text{dB}$ in 0.125dB steps. The default setting is 0dB .

4.7.5 Channel Status

Channel Status data (CS) is an integral part of the digital audio AES specification. It allows certain parameters of the AES signal to be included to assist with downstream processing. In general there are two ways to handle the CS; either pass through untouched, as would happen with a DA for example or regenerate, which must be done if the signal has been significantly processed.

In the multiplexing sections of the V6251 series we either create the digital audio direct from analogue in an ADC or we re-sample a digital input. In both cases it is necessary to re-create the CS bits.

Because in the past there has been difficulty in guaranteeing the quality of the CS data in the broadcast environment, and that the V6351 series can easily mix and combine audio from different source it has been decided to always re-generate the CS bits. The regenerated CS bits include the module type number as the Origin Data.

4.7.6 Maximum Audio Level (MAL)

The Maximum Audio Level (MAL) is a way of setting how digital audio is represented in the digital domain. The MAL is that level of audio, relative to 0dB in the analogue domain, which is at the limit of the digital gamut. Any more would result in clipping. It has to be applied correctly at the analogue and digital interfaces – ADCs and DACs.

While the V6351 Series can have ADCs and DACs there is only one MAL setting. If a purely digital interface is fitted then it has no meaning and cannot be set. With an analogue module it can be set by going to:

AUDIO	MAL	+18dB	Default is +18dB. Adjustable from +12 to +24dB in 1dB steps
--------------	------------	--------------	---

The MAL is sometimes referred to as a negative number. This often refers to a particular signal level relative to maximum, for example tone. MAL, as used here, is a better description.

Changing the MAL has opposite effects on the ADC and DAC. Increasing the MAL on the ADC increases the headroom and therefore reduces the apparent signal level. This is counter-intuitive. On the DAC increasing the MAL implies that the digital signal has more headroom, and therefore it will increase the output level. This is intuitive. Setting the MAL should be done system-wide within an installation and not used as a gain control.

4.8 SYSTEM

4.8.1 GPIs

The V6351 Series has three GPI inputs so that external hardware can simply select certain parameters. The GPI inputs all have a 4k7 pull-up resistor to +5V, and the external hardware should take the pin to Ground to activate the GPI. The GPI input is on the rear panel HDD connector. See section 2.3.3 for details.

The options for the three GPIs are as follows:

CONFIG	GPI	OFF	GPI disabled
		SDI 2	Select SDI 2, if available by link setting.
		A Mono	
		B Mono	
		AB Mono	
		C Mono	
		D Mono	
		CD Mono	
		A LR Rev	
		B LR Rev	
		C LR Rev	
		D LR Rev	
		AB Swap	
		CD Swap	

These GPI operation do not necessarily have a one to one relationship with front panel or DART commands. They are intended to provide useful hardware control functions.

4.8.2 VCO Centre Frequency

Normally, the video output is locked to the video input, if present. If there is no signal connected then the output will free run at the nominal centre frequency of the on board crystal. This centre frequency can be adjusted under the **CALIB : CntrFreq** menu, but this should not normally be necessary in the field. It will be necessary first to pour the unit into its calibration mode by selecting **CALIB : Cal Mode** to **Cal On**.

4.8.3 Version Numbers

There are three separate items of software/firmware in this series of modules and they all have separate version numbers. These can be read on the following read only menus:

STATUS	Soft Ver	0.00.00	The operating code
STATUS	FPGA Ver	0.00.00	The FPGA data
STATUS	PCB Ver	0.00.00	The hardware version of the PCB

4.8.4 Display Sleep

Since, for the vast majority of their life, the V6351 Series modules will operate behind the front panel of a rack frame the display on the local front panel will not be visible so it will go to sleep after a certain time. This timeout delay can be changed on the **ENG' ING : Sleep** menu to be anything between 0 and 30 minutes; 0 minutes means that it will stay on indefinitely. The sleep timeout always counts from the last front panel button push. The default time is 5 minutes.

The panel can also be forced into its sleep mode by moving up a level from the Top Level menu which displays the module type, **V6351** etc.

To get the display to come on again simply press one of the buttons and the menus will start again at the Top Level.

4.8.5 Display Brightness

The brightness of the front panel display can be adjusted on the **ENG' ING : LEDLevel** menu.

ENG' ING	LEDLevel	ζ ζ ζ ζ
-----------------	-----------------	---------

5. CALIBRATION

This section describes how to calibrate the unit as it is done in the factory. The modules do not contain any potentiometers, but like most equipment with analogue parts still needs to be calibrated. Normally this calibration is done in the factory and should not need to be repeated in the field but this section describes the procedure and is included for completeness.

High quality, calibrated test equipment should be used for this calibration. Note that it is not possible to return to the pre-calibration settings other than by making a note of the values and re-entering them.

5.1 SET-UP

There is a separate Main Level Menu for Calibration and this should be used throughout. The first sub-level menu is Cal Mode which can be used to turn calibration ON:

```
CALIB      Cal Mode  Cal Off
                        Cal On
```

The calibration mode must be turned ON before any parameter can be adjusted. The calibration mode will be turned OFF in one of four ways:

1. Manually on the **CALIB** : **Cal Mode** menu.
1. By going up to the Top Level Menu
2. By re-powering the unit.
3. By letting the display timeout and go to sleep mode.

When the calibration mode is on then the unit will automatically set up the required conditions in the unit as you enter each sub-menu. For example if you go into the CntrFreq sub-menu the unit will automatically go into free run.

5.2 FREE-RUN FREQUENCY

The modules have a voltage controlled crystal oscillator which is usually locked to the external video reference or to the input video. However if there is no input or reference then it will free-run and this free running frequency should be set. The oscillator is not accurate enough to be used as a frequency reference but nevertheless should be set close to the ideal so that any succeeding SDI equipment will be able to lock to its output, and so that when in free run it will only drift slowly away from its starting reference.

To calibrate the frequency set the unit into Free Run by turning Cal Mode ON and selecting the CntrFreq sub-menu.

```
CALIB      Cal Mode  Cal On
```

Now monitor the clock frequency on TP 14, or compare the output picture movement on a monitor with an accurate external reference and adjust the frequency on.

```
CALIB      CntrFreq          Range is -127 to +128
```

The setting is stored on the unit in non-volatile memory, and should not need regular adjustment.

6. TROUBLE SHOOTING GUIDE (FAQS)

This section is to be a help in solving some common difficulties with the V6751 Series. If there is no control from the front panel first check that the switch is set to Local.

6.1 VIDEO

Symptom	Possible explanation
No Video Output, with SDI 1 selected	Check left SDI LED on front panel. If OFF then check that there is actually an i/p signal. If ON then check that SDI 1 is being selected. It is possible that the RefSrc has been set to AES or FreeRun which would also cause the O/P to be Black.
No Video Output, with SDI 2 selected	As above, but use the Right hand LED
O/P Black with all inputs.	Check RefSrc on the ENG' ING menu. If it is set to AES or FreeRun then the O/P will be set to black.
Can't select SDI 2	Check that links LKs 1 & 2 are set North.
Downstream equipment can't lock to output when module is in free-run.	Check that the free-run frequency has been set. Go to : CALIB Cal Mode and set it to Cal ON . Then select CntrFreq and adjust. The normal setting should be between – 50 and +50.

6.2 AUDIO

Symptom	Possible explanation
No audio output from Demux	Is the selected video input present? Check that the correct audio module is fitted, i.e. analogue or digital Check that the selected group(s) are actually present on the input. Either the top level indicator, or STATUS: I/P Grps will show this. Check that the audio hasn't been disabled in teh Audio Processing.
Corrupted audio on Mux O/P	Is there a group conflict? Are you trying to append to audio from a Tektronix TSG422 which does not perform to the specification? You must Blank out any audio from this generator.
No audio on Mux output	Check that the correct input module is fitted , i.e. analogue or digital. Check that there is an AES signal present on STATUS: AES AB or AES CD . Check that you are monitoring the actual group(s) being used. Check that the audio hasn't been disabled in teh Audio Processing.

6.3 OTHERS

Symptom	Possible explanation
Display never goes to sleep	Check whether the Sleep delay has been set to 0 Mins which means stay awake.
A GPI does not work	Check for GPI priority. GPI 1 overrules GPI 2 which overrules GPI 3. Each one can be checked on STATUS : GPI STA .
Front panel can change but there is no control	The unit is probably in Remote mode. The panel is still live for monitoring.

7. FRONT PANEL MENUS

The next sections show the menus available on V6351 Series.

Some menu items may only appear with certain configurations.

7.1 V6351 – DUAL MUX

V6351					
MAIN	AUDIO	STATUS	ENG' ING	CALIB	CONFIG
Video	MAL ¹	Variant	Ref Src	Cal Mode	GPI 1
AB MUXgP		Options	Format	ADC A(L) ²	GPI 2
Norm		SDI I/P	Anc Data	ADC A(R)	GPI 3
		SDI 2	AB Bits	ADC B(L)	Banner
		I/P Grps	AB Mode	ADC B(R)	Password
		AB OPAud	A On/Off	ADC C(L)	Variant
		AES AB	B On/Off	ADC C(R)	AudioOpt
		GPI STA	A Format	ADC D(L)	TestMode
		V Module	B Format	ADC D(R)	
		A Module	O/P EDH	CntrFreq	
		Soft Ver	Sleep	Norm	
		FPGA Ver	LEDLevel		
		PCB Ver	Norm		

7.2 V6351AP – DUAL MUX WITH AP

V6351AP						
MAIN	AUDIO	DELAY	STATUS	ENG' ING	CALIB	CONFIG
Video	A IPGain	Delay A	Variant	Ref Src	Cal Mode	GPI 1
AB MUXgP	B IPGain	Delay B	Options	Format	ADC A(L) ³	GPI 2
Norm	A Setup	norm	SDI I/P	Anc Data	ADC A(R)	GPI 3
	B Setup		SDI 2	AB Bits	ADC B(L)	Banner
	A O/P		I/P Grps	AB Mode	ADC B(R)	Password
	B O/P		AB OPAud	A On/Off	ADC C(L)	Variant
	C O/P		AES AB	B On/Off	ADC C(R)	AudioOpt
	D O/P		AES CD	A Format	ADC D(L)	DelayOpt
	A OPGain		GPI STA	B Format	ADC D(R)	TestMode
	B OPGain		V Module	DlyCnfig	CntrFreq	
	MAL ⁴		A Module	O/P EDH	Norm	
	Norm		Soft Ver	Sleep		
			FPGA Ver	LEDLevel		
			PCB Ver	Norm		

¹ Analogue I/O only

² ADC sub-module only

³ ADC sub-module only

⁴ Analogue I/O only

7.3 V6351Q – QUAD MUX

		V6351Q			
MAIN	AUDIO	STATUS	ENG' ING	CALIB	CONFIG
Video	MAL ⁵	Variant	Ref Src	Cal Mode	GPI 1
AB MUXgP	Norm	Options	Format	ADC A(L)	GPI 2
CD MUXgP		SDI I/P	Anc Data	ADC A(R)	GPI 3
Norm		SDI 2	AB Bits	ADC B(L)	Banner
		I/P Grps	CD Bits	ADC B(R)	Password
		AB OPAud	AB Mode	ADC C(L)	Variant
		CD OPAud	CD Mode	ADC C(R)	AudioOpt
		AES AB	A On/Off	ADC D(L)	TestMode
		AES CD	B On/Off	ADC D(R)	
		GPI STA	C On/Off	CntrFreq	
		V Module	D On/Off	Norm	
		A Module	A Format		
		Soft Ver	B Format		
		FPGA Ver	C Format		
		PCB Ver	D Format		
			DlyCnfig		
			O/P EDH		
			Sleep		
			LEDLevel		
			Norm		

7.4 V6351QAP – QUAD MUX WITH AP

		V6351QAP				
MAIN	AUDIO	DELAY	STATUS	ENG' ING	CALIB	CONFIG
Video	A IPGain	Delay A	Variant	Ref Src	Cal Mode	GPI 1
AB MUXgP	B IPGain	Delay B	Options	Format	ADC A(L)	GPI 2
CD MUXgP	C IPGain	Delay C	SDI I/P	Anc Data	ADC A(R)	GPI 3
Norm	D IPGain	Delay D	SDI 2	AB Bits	ADC B(L)	Banner
	A Setup	norm	I/P Grps	CD Bits	ADC B(R)	Password
	B Setup		AB OPAud	AB Mode	ADC C(L)	Variant
	C Setup		CD OPAud	CD Mode	ADC C(R)	AudioOpt
	D Setup		AES AB	A On/Off	ADC D(L)	DelayOpt
	A O/P		AES CD	B On/Off	ADC D(R)	TestMode
	B O/P		GPI STA	C On/Off	CntrFreq	
	C O/P		V Module	D On/Off	Norm	
	D O/P		A Module	A Format		
	A OPGain		Soft Ver	B Format		
	B OPGain		FPGA Ver	C Format		
	C OPGain		PCB Ver	D Format		
	D OPGain			DlyCnfig		
	MAL ⁶			O/P EDH		
	Norm			Sleep		
				LEDLevel		
				Norm		

⁵ Analogue I/O only

⁶ Analogue I/O only

7.5 V6353 – DUAL DEMUX

V6353					
MAIN	AUDIO	STATUS	ENG' ING	CALIB	CONFIG
Video AB DMXgP Norm	MAL ⁷	Variant Options SDI I/P SDI 2 I/P Grps AB IPAud AES AB AES CD GPI STA V Module A Module Soft Ver FPGA Ver PCB Ver	Ref Src Format Anc Data AB Mode A On/Off B On/Off A Format B Format O/P EDH Sleep LEDLevel Norm	Cal Mode DAC A(L) ⁸ DAC A(R) DAC B(L) DAC B(R) DAC C(L) DAC C(R) DAC D(L) DAC D(R) CntrFreq Norm	GPI 1 GPI 2 GPI 3 Banner Password Variant AudioOpt TestMode

7.6 V6353AP – DUAL DEMUX WITH AP

V6353AP						
MAIN	AUDIO	DELAY	STATUS	ENG' ING	CALIB	CONFIG
Video AB MUXgP Norm	A IPGain B IPGain A Setup B Setup A O/P B O/P A OPGain B OPGain MAL ¹⁰ Norm	Delay A Delay B norm	Variant Options SDI I/P SDI 2 I/P Grps AB OPAud AES AB GPI STA V Module A Module Soft Ver FPGA Ver PCB Ver	Ref Src Format Anc Data AB Mode A On/Off B On/Off A Format B Format DlyCnfig O/P EDH Sleep LEDLevel Norm	Cal Mode DAC A(L) ⁹ DAC A(R) DAC B(L) DAC B(R) DAC C(L) DAC C(R) DAC D(L) DAC D(R) CntrFreq Norm	GPI 1 GPI 2 GPI 3 Banner Password Variant AudioOpt DelayOpt TestMode

⁷ Analogue I/O only

⁸ DAC sub-module only

⁹ DAC sub-module only

¹⁰ Analogue I/O only

7.7 V6353Q – QUAD DEMUX

V6353Q					
MAIN	AUDIO	STATUS	ENG' ING	CALIB	CONFIG
Video	MAL ¹¹	Variant	Mode	Cal Mode	GPI 1
AB DMXgP	Norm	Options	Ref Src	DAC A(L)	GPI 2
CD DMXgP		SDI I/P	Format	DAC A(R)	GPI 3
Norm		SDI 2	Anc Data	DAC B(L)	Banner
		I/P Grps	AB Mode	DAC B(R)	Password
		AB IPAud	CD Mode	DAC C(L)	Variant
		CD IPAud	A On/Off	DAC C(R)	AudioOpt
		AES AB	B On/Off	DAC D(L)	TestMode
		AES CD	C On/Off	DAC D(R)	
		GPI STA	D On/Off	CntrFreq	
		V Module	A Format	Norm	
		A Module	B Format		
		Soft Ver	C Format		
		FPGA Ver	D Format		
		PCB Ver	O/P EDH		
			Sleep		
			LEDLevel		
			Norm		

7.8 V6353QAP – QUAD DEMUX WITH AP

V6353QAP						
MAIN	AUDIO	DELAY	STATUS	ENG' ING	CALIB	CONFIG
Video	A IPGain	Delay A	Variant	Mode	Cal Mode	GPI 1
AB DMXgP	B IPGain	Delay B	Options	Ref Src	DAC A(L)	GPI 2
CD DMXgP	C IPGain	Delay C	SDI I/P	Format	DAC A(R)	GPI 3
Norm	D IPGain	Delay D	SDI 2	Anc Data	DAC B(L)	Banner
	A Setup	norm	I/P Grps	AB Mode	DAC B(R)	Password
	B Setup		AB IPAud	CD Mode	DAC C(L)	Variant
	C Setup		CD IPAud	A On/Off	DAC C(R)	AudioOpt
	D Setup		AES AB	B On/Off	DAC D(L)	DelayOpt
	A O/P		AES CD	C On/Off	DAC D(R)	TestMode
	B O/P		GPI STA	D On/Off	CntrFreq	
	C O/P		V Module	A Format	Norm	
	D O/P		A Module	B Format		
	A OPGain		Soft Ver	C Format		
	B OPGain		FPGA Ver	D Format		
	C OPGain		PCB Ver	DlyCnfig		
	D OPGain			O/P EDH		
	MAL ¹²			Sleep		
	Norm			LEDLevel		
				Norm		

¹¹ Analogue I/O only

¹² Analogue I/O only

7.9 V6355 – DEMUX/MUX

		V6355			
MAIN	AUDIO	STATUS	ENG' ING	CALIB	CONFIG
Video	MAL ¹³	Variant	Mode	Cal Mode	GPI 1
AB DMXgP	Norm	Options	Ref Src	ADC A(L) ¹⁴	GPI 2
CD DMXgP		SDI I/P	Format	ADC A(R)	GPI 3
Norm		SDI 2	Anc Data	ADC B(L)	Banner
		I/P Grps	CD Bits	ADC B(R)	Password
		AB IPAud	AB Mode	ADC C(L)	Variant
		CD OPAud	CD Mode	ADC C(R)	AudioOpt
		AES AB	A On/Off	ADC D(L)	TestMode
		AES CD	B On/Off	ADC D(R)	
		GPI STA	C On/Off	DAC A(L) ¹⁵	
		V Module	D On/Off	DAC A(R)	
		A Module	A Format	DAC B(L)	
		Soft Ver	B Format	DAC B(R)	
		FPGA Ver	C Format	DAC C(L)	
		PCB Ver	D Format	DAC C(R)	
			O/P EDH	DAC D(L)	
			Sleep	DAC D(R)	
			LEDLevel	CntrFreq	
			Norm	Norm	

7.10 V6355AP – DEMUX/MUX WITH AP

		V6355AP				
MAIN	AUDIO	DELAY	STATUS	ENG' ING	CALIB	CONFIG
Video	A IPGain	Delay A	Variant	Mode	Cal Mode	GPI 1
AB DMXgP	B IPGain	Delay B	Options	Ref Src	ADC A(L) ¹⁶	GPI 2
CD MUXgP	C IPGain	Delay C	SDI I/P	Format	ADC A(R)	GPI 3
Norm	D IPGain	Delay D	SDI 2	Anc Data	ADC B(L)	Banner
	A Setup	norm	I/P Grps	AB Mode	ADC B(R)	Password
	B Setup		AB IPAud	CD Mode	ADC C(L)	Variant
	C Setup		CD IPAud	A On/Off	ADC C(R)	AudioOpt
	D Setup		AES AB	B On/Off	ADC D(L)	DelayOpt
	A O/P		AES CD	C On/Off	ADC D(R)	TestMode
	B O/P		GPI STA	D On/Off	DAC A(L) ¹⁷	
	C O/P		V Module	A Format	DAC A(R)	
	D O/P		A Module	B Format	DAC B(L)	
	A OPGain		Soft Ver	C Format	DAC B(R)	
	B OPGain		FPGA Ver	D Format	DAC C(L)	
	C OPGain		PCB Ver	DlyCnfig	DAC C(R)	
	D OPGain			O/P EDH	DAC D(L)	
	MAL ¹⁸			Sleep	DAC D(R)	
	Norm			LEDLevel	CntrFreq	
				Norm	Norm	

¹³ Analogue I/O only

¹⁴ ADC () for Analogue I/P module only

¹⁵ DAC () for Analogue O/P module only

¹⁶ ADC () for Analogue I/P module only

¹⁷ DAC () for Analogue O/P module only

¹⁸ Analogue I/O only

8. CONTROLS

These tables show a complete list of all the parameters that can be controlled locally for the various configurations. Unless otherwise shown they can also be controlled over the DART remote control system. Not all menus are available at any one time, since they depend on the module and which type of audio sub-module may be fitted, and sometimes on the operating conditions.

The tables also show the full range of the controls and their ranges and normalised value, if appropriate. The normalised value or setting is shown by the 'n'.

8.1 VIDEO AND GROUPS - MAIN

MAIN	Video	SDI 1	n	
		SDI 2		If enabled on links
	AB DMXGp	AB Gp 1		V6353, V6353Q V6355 only
		AB Gp 2		
		AB Gp 3		
		AB Gp 4		
	CD DMXGp	CD Gp 1		V6353Q only
		CD Gp 2		
		CD Gp 3		
		CD Gp 4		
	AB MUXGp	AB Gp -		V6351, V6351Q only
		AB Gp 1		
		AB Gp 2		
		AB Gp 3		
		AB Gp 4		
	CD MUXGp	CD Gp -		V6351, V6351Q, V6355
		CD Gp 1		
		CD Gp 2		
		CD Gp 3		
		CD Gp 4		

8.2 AUDIO PROCESSING – AUDIO

AUDIO	A IPGain	+15.88dB		Resolution = 0.125dB
		↓		
		+0.00dB	n	
		↓		
		-16.00dB		
	B IPGain		n	As A I/P Gain
	C IPGain		n	As A I/P Gain
	D IPGain		n	As A I/P Gain
	A Setup	Normal		n
		A L Both		
		A R Both		
		aLR Swap		
		A Mono		
		A L Only		
		A R Only		
		A Off		
	B Setup			As A Setup
	C Setup			As A Setup
	D Setup			As A Setup
	A O/P	A A	n	
A B				
A C				
A D				
A A+B				
A A+C				

	A	A+D	
	A	A+B+C	
	A	A+B+D	
	A	A+B+C+D	
	A	A+C+D	
	A	B+C	
	A	B+D	
	A	B+C+D	
	A	C+D	
	A	OFF	
B O/P	B	B	n
	B	A	
	B	C	
	B	D	
	B	B+A	
	B	B+C	
	B	B+D	
	B	B+A+C	
	B	B+A+D	
	B	B+A+C+D	
	B	B+C+D	
	B	A+C	
	B	A+D	
	B	A+C+D	
	B	C+D	
	B	OFF	
C O/P	C	C	n
	C	D	
	C	B	
	C	A	
	C	C+A	
	C	C+B	
	C	C+D	
	C	C+A+B	
	C	C+A+D	
	C	C+A+B+D	
	C	C+B+D	
	C	A+B	
	C	A+D	
	C	A+B+D	
	C	B+D	
	C	OFF	
D O/P	D	D	n
	D	C	
	D	B	
	D	A	
	D	D+A	
	D	D+B	
	D	D+C	
	D	D+A+B	
	D	D+A+C	
	D	DD+A+B+C	
	D	D+B+C	
	D	A+B	
	D	A+C	
	D	A+B+C	
	D	B+C	
	D	OFF	
A OPGain	+15.88dB		
	↓		
	+0.00dB		n

Resolution = 0.125dB

		↓		
		-16.00dB		
B OPGain			n	As A O/P Gain
C OPGain			n	As A O/P Gain
D OPGain			n	As A O/P Gain
MAL		+12dB		
		↓		
		+18dB	n	
		↓		
		+24dB		

8.3 OPERATING CONDITIONS – STATUS

STATUS	Variant	V6351		May have AP appended
		V6351Q		
		V6353		
		V6353Q		
		V6355		
	Options	None		
		Audio		
	SDI I/P	IP 625 3		
		IP 525 3		
		IP FAIL		
	SDI I/P2	N/A		
		Avail		
	I/P Grps	None		No groups occupied.
	AB OPAud	AB MUX OK		AB Mux Group is available
		AB CONFL		AB Group Conflict
	CD OPAud	AB MUX OK		CD Mux Group is available
		AB CONFL		CD Group Conflict
	AES AB	AES AxBx		Indicates whether AES A and B are present or not. Applies to either Mux or Demux.
	AES CD	AES CxDx		Indicates whether AES C and D are present or not. Applies to either Mux or Demux.
	GPI STA	1↓ 2↓ 3↓		↓ ⇒ Inactive. ↑ ⇒ Active.
	V Module	None		Not used on this series of module.
	A Module	00:OP DD		All Digital I/P module
		02:IP AA		All Analogue I/P module
		08:OP DD		All Digital O/P module
		10:OP AA		All Analogue O/P module
	Soft Ver	01.00.00		The operating code
	FPGA Ver	01.01		The Video FPGA data
PCB Ver	01		The Main board PCB version.	

8.4 ENGINEERING – ENG' ING

ENG' ING	Ref Src	Auto	n	
		AES		
		Free-run		
Format	Format	Fmt Auto	n	
		Fmt S625		
		Fmt S525		
Anc Data	Anc Data	Anc Blnk	n	
		Anc Pass		
AB Bits	AB Bits	AB 20bit	n	
		AB 24bit		
CD Bits	CD Bits	AB 20bit	n	
		AB 24bit		
AB Mode	AB Mode	AB Synch	n	
		AB Async		
CD Mode	CD Mode	CD Synch	n	
		CD Async		
A On/Off	A On/Off	A On	n	
		A Off		
B On/Off	B On/Off	B On	n	
		B Off		
C On/Off	C On/Off	C On	n	
		C Off		
D On/Off	D On/Off	D On	n	
		D Off		
A Format	A Format	A Norm	n	
		A nonAES		
B Format	B Format	B Norm	n	
		B nonAES		
C Format	C Format	C Norm	n	
		C nonAES		
D Format	D Format	D Norm	n	
		D nonAES		
DlyCnfg	DlyCnfg	Dly 4Ch	n	Delay is not yet implemented
		Dly 2Ch		
		Dly 1Ch		
O/P EDH	O/P EDH	EDH On	n	
		EDH Off		
Sleep	Sleep	5 min	n	Variable 0 to 30 minutes.
LEDLevel	LEDLevel			

8.5 CALIBRATION – CALIB

CALIB	Cal Mode	Cal Off	n	
		Cal On		Must be set ON to enable correct conditions during calibration
	DAC A(L)	-128		
		+0	n	
		+127		
	DAC A(R)	-128		
		+0	n	
		+127		
	DAC B(L)	-128		
		+0	n	
		+127		
	DAC B(R)	-128		
		+0	n	
		+127		
	ADC A(L)	-128		
		+0	n	
		+127		
	ADC A(R)	-128		
		+0	n	
		+127		
	ADC B(L)	-128		
		+0	n	
		+127		
	ADC B(R)	-128		
		+0	n	
		+127		
	CntrFreq	Frq=-128		Free-run Frequency
		Frq= +0		
		Frq=+127		

8.6 CONFIGURATION – CONFIG

CONFIG	GPI 1	OFF	n	
		SDI 2		
		A Mono		
		B Mono		
		AB Mono		
		C Mono		
		D Mono		
		CD Mono		
		A LR Rev		
		B LR Rev		
		C LR Rev		
		D LR Rev		
		AB Swap		
		CD Swap		
	GPI 2			As GPI 1
	GPI 3			As GPI 1
	Banner	On	n	
		Off		
	Password			
	Variant	V6351QAP		For example
	AudioOpt	On		
		Off		
	TestMode	Off	n	
		On		Password required

8.7 TEST MODE – TEST

This section is not required for users, but is shown here for completeness.

It can only be accessed after turning Test Mode ON on the **Config** menu.

TEST	AUD_ERRA	0000	n	
		1F01		
	DMX_STA	00000000	n	Demux Status
	Test			
	GENN_AB			
	GENN_CD			
	WReg0			
	WReg1			
	WReg2			
	WReg3			
	WReg4			
	WReg5			
	WReg6			
	WReg7			
	WReg8			
	WReg9			
	WReg10			
	WReg11			
	WReg12			
	WReg13			
	WReg14			
	WReg15			
	RReg0			
	RReg1			
	RReg2			
	RReg3			
	RReg4			
	RReg5			
	A 8427			
	B 8427			
	C 8427			
	D 8427			

9. SOFTWARE VERSIONS

This table gives a brief summary of the various versions of software that have been issued with the corrections and improvements for each. This has been included in this manual so that users with earlier versions can understand when some facilities, or menu options may not appear.

VERSION	DATE	REMARKS
1.4	10-12-04	Full DART Processing All module types supported (Including V6355) AES Locking corrected Force Standard/Auto working Menu rationalisation
1.1	27-10-04	Initial Issue