



V6414

HD Down Converter

User Guide

Issue: 2.0

© Pro-Bel Ltd

www.pro-bel.com



Contents

1	Description	5
1.1	General	5
1.2	Supported Video Standards	6
2	Installation	7
2.1	Rear Panel	7
2.2	Connections	8
2.3	Module and Environmental Specifications	8
2.4	Signal Specifications	9
2.5	Timing Adjustment Ranges	9
2.5.1	Synchroniser Mode	10
2.5.2	Delay Mode	10
2.5.3	Minimum Delay (Intrinsic Delay)	11
2.6	Hardware	11
2.6.1	The PCB	11
2.6.2	Links and Switches	12
2.6.3	Fuse	12
2.6.4	Flash Memory Card	13
2.7	Front Panel	14
2.7.1	Direct Indications	14
2.7.2	Display and Switches	15
2.7.3	Remote/Local Control	15
3	System Operation	16
3.1	Local Control	16
3.1.1	Start Up	16
3.1.2	Option Abbreviations	16
3.1.3	Menu Control	17
3.1.4	Menu Examples	17
3.1.5	Sleep	18

Contents (Cont'd)

3.2	Core Product Features	18
3.2.1	SDI Inputs	18
3.2.2	SDI Reclocked & Buffered Output	18
3.2.3	SDI Main Outputs	19
3.2.4	Video Reference	19
3.2.5	Standard Detection	19
3.2.6	TRS Signals	19
3.2.7	EDH (SD operation only)	19
3.2.8	Illegal Codes	20
3.2.9	Horizontal and Vertical Blanking Interval Data	20
3.2.10	SDI Input Fail	20
3.2.11	Video Reference Fail	21
3.2.12	GPI Configuration	21
3.2.13	Video Reference Mismatch	21
3.2.14	Delay Signal	22
3.2.15	VCO Centre Frequency	23
3.2.16	Version Numbers	23
3.2.17	Memory Size	23
3.2.18	Display Sleep	23
3.2.19	Display Brightness	24
3.2.20	Conversion Modes	24
3.2.21	Down Converter Aspect Ratios	25
3.2.22	Horizontal Resolution	25
3.2.23	Vertical Resolution	25
3.2.24	Bypass Delay (Standard Definition)	25
3.2.25	Motion Adaption	26
3.3	Frame Synchroniser and Field Delay Options	26
3.3.1	Manual Freeze	26
3.3.2	Timing & Delay Control	26
3.3.3	Test Pattern Generator (TPG)	31
3.4	Video Processing Amplifier	32
3.4.1	Video Gain	32
3.4.2	Chroma Gain	33
3.4.3	Black Level	33
3.4.4	Hue Shift	33
3.4.5	Dynamic Rounding	33
3.4.6	Limiting	34
3.4.7	Fade to Black	34
3.5	Audio Handling	35
3.5.1	Audio Group Selection	35
3.5.2	Audio Group Status	35
3.6	Closed Captions	36
3.6.1	SD Captions	36
3.6.2	HD Captions	36



Contents (Cont'd)

3.7	Wide Screen Signalling (WSS)	37
3.7.1	General	37
3.7.2	ETSI Line 23 WSS Insertion	37
3.7.3	Video Index (VI) Insertion	38
3.8	Time Code and Source Identification	39
3.8.1	General	39
3.8.2	DVITC Time Code Processing Controls	39
3.8.3	Ancillary Time Code (ATC) Processing Controls	40
3.8.4	Source Identification (SID) Processing Controls	41
4	Calibration	42
4.1	Set-Up	42
4.2	Free-Run Frequency	43
5	Controls	44
5.1	Video Processing – VIDEO	44
5.2	Operating Conditions – STATUS	46
5.3	Engineering – ENG'ING	48
5.4	Calibration – CALIB	49
5.5	Configuration – CONFIG	50
5.6	Video Proc Amp – PROC AMP	51
5.7	Audio Handling – AUDIO	52
5.8	Closed Captioning – CCAPTION	52
5.9	Wide Screen Signalling – WSS	53
5.10	Auxillary Data – AUX DATA	53
6	Appendix	54
6.1	Trouble Shooting Guide (Frequently Asked Questions)	54
6.2	Initialization, Power On-Selftest & Error Messages	55
6.2.1	Board Initialization Sequence	55
6.2.2	SDRAM Test	56
6.3	Menu Structure	56
6.4	ETSI Line 23 and Video Index Insertion Codes	58



1 Description

The module described in this manual forms part of the Vistek 1600 range of interface products. Although it processes High Definition (HD) video signals, it is fully compatible with all other products in the range in terms of its form factor, power supply requirements and control interface. The V6414 is a 3U high card that can be fitted into a V1606 rack or a V6011 '1-Box', from which it obtains its power and control. A passive rear module is required for all signal interconnections.

The V6414 down converter module offers a number of optional Add-Ons:

VP: **V**ideo **P**roc Amp

SY: Frame **S**ynchroniser

FD: **F**ield/**F**rame **D**elay (requires the SY option to be enabled)

CP: Closed **C**aptioning

AH: **A**udio **H**andling

1.1 General

The **V6414 HD Down Converter** takes an HD input signal and converts it to a Standard Definition (SD) output at the same frame rate as the input. While the unit handles all the interlacing, filtering and scaling required, it does not change the frame rate. Therefore, both the input and output standards must have the same frame rate. The unit automatically detects the input signal standard and sets the output standard, i.e. 525 lines @ 59.94Hz or 625 lines @ 50Hz, accordingly. The operator can select between different aspect ratios (e.g. anamorphic, letterbox, centre-cutout). If the detected input standard is SD, the unit switches automatically into a bypass mode where it maintains the same processing delay that is normally introduced by the down-conversion process. If the module comes with the Audio Handling (AH) option fitted, embedded Audio information will be retained by de-embedding it in the HD domain and re-embedding it in the SD domain. Available options for the V6414 are: VP, SY, FD, CP and AH.

The unit has two independent inputs, which can be selected either on the front panel or remotely via Vistek's control interface 'DART'. It also has a fully re-clocked and buffered output, which is after the input signal selection. Generally it is recommended to terminate unused input BNCs in order to improve the unit's noise susceptibility.

The reference input has two BNCs, so a passive loop-through is available. The reference can be either a conventional Black & Burst signal (sometimes known as bi-level sync) or a tri-level sync, which is a newer signal specifically for synchronising HD signals. The unit will automatically detect which type is being used and adapt accordingly. A 75Ω reference termination can be selected using a switch on the I/O Daughter Board.



Vistek V6414 HD Down Converter

If a V6414 is fitted with the Frame Synchroniser (SY) option, then the card provides a tracking delay output from a BNC on the rear panel assembly. This signal may be used in connection with a 3rd party Audio Processor. Alternatively, or in addition to this, if the unit is used in combination with Vistek's V6302 Advanced Audio Processor and a dedicated double-width rear panel, the tracking delay information will be passed internally from the down converter module to the Audio Processor.

The V6414 offers two (identical) Output BNCs, capable of driving either SD or HD SDI.

There is a versatile front panel with an alphanumeric display, which lets the operator set up a large number of parameters and read the internal status of the unit. The front panel operates in the same way as many of the more complex units in the range.

1.2 Supported Video Standards

The Bit Serial Interface for all listed HD modes is in accordance with SMPTE specification 292M. For all SD modes, the Serial Digital Interface is in accordance with ANSI/SMPTE 259M.

Supported conversion modes at the time of printing (FPGA Firmware Version V05.04)

Input Standard	Output Standard	Aspect Ratios
1080i59	525i59	4:3 Anamorphic 16:9 Letterbox 14:9 Letterbox 4:3 Centre-Cutout
720p59	525i59	
1080i50	625i50	
720p50	625i50	
525i59	525i59	n.a.
625i50	625i50	n.a.

Furthermore, the V6414 HD Down Converter performs the colour space conversion between the HD and SD domains in accordance with the following standards:

ITU-R BT.709-5 (HD)

ITU-R BT.601-5 (SD)

F Things to remember:

The V6414 cannot perform field- or frame-rate conversions! When used in connection with the 'SY' option, the Reference's frame rate must either match the Video Input's field- or frame-rate or must be an integer fraction there from.



2 Installation

2.1 Rear Panel

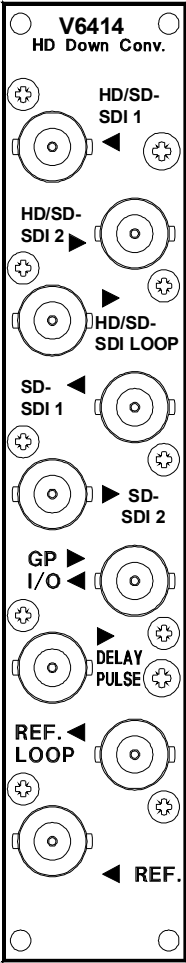



Vistek V6414 HD Down Converter

2.2 Connections

The following table shows the function of the rear panel BNCs:

Connector	Type	Function
▶ HD/SDI 1	BNC	HD/SDI Video Input 1
▶ HD/SDI 2	BNC	HD/SDI Video Input 2
◀ HD/SDI LOOP	BNC	HD/SDI Reclocked and Buffered Loop-through Output
◀ HD/SDI 1	BNC	SDI Main Output 1
◀ HD/SDI 2	BNC	SDI Main Output 2
▶ ◀ GPIO	BNC	General Purpose Input or Output (bi-directional)
◀ DELAY PULSE	BNC	Delay Pulse Output.
◀ REF. LOOP	BNC	Reference Loop Output
▶ REF.	BNC	Reference Input. Switch selectable termination on board.

2.3 Module and Environmental Specifications

Parameter	Environmental Specification
Module Size	Standard V1600 range form factor; fits in V1606 3U rack or V6011 '1-Box'
Rear Panels	V16HR3C Single width rear V16HR3D Double width rear (for V6302 combo) V16HR3E Triple width rear (for V6302 combo)
Operating Voltage	+9..+18V
Power Consumption	+15V / 1A (15W typical)
Operating Temperature	0 to +60°C
Storage Temperature	-40°C to +85°C
Relative Humidity	95% non-condensing

2.4 Signal Specifications

Signal	Type	Comments
Video Inputs	75Ω BNC	Input Format: SMPTE259M or SMPTE292M Input Impedance: 75 Ohm Return Loss: > 15dB, 5MHz – 1.5GHz Equal. Cable Length: 0-250m @ 270Mbps 0-100m @ 1.5Gbps
Video Outputs	75Ω BNC	Output Format: SMPTE259M or SMPTE292M Output Impedance: 75 Ohm Return Loss: > 15dB, 5MHz – 1.5GHz Jitter Performance: < 0.2UI p-p (Timing @ 270Mbps) < 0.2UI p-p (Alignment @ 270Mbps) < 1UI p-p (Timing @ 1.485Gbps) < 0.2UI p-p (Alignment @ 1.485Gbps) Amplitude: 800mV p-p (terminated) Drive Capability: > 250m @ 270Mbps (Belden 8281) > 100m @ 1.5Gbps (Belden 1694A)
Video Reference Input	Bi-Level or Tri-Level	1V Composite video, but Black & Burst is recommended. Tri-Level sync as per SMPTE274M or 296M.
Tracking Delay Pulse	LVTTL with +/- 24mA drive capability	Positive pulse represents the video insertion delay. Repetition rate is 2 frames.
GP Input	0V to 5.5V with Schmitt-Trigger characteristic	Positive-going input threshold voltage: 1.75V typ. Negative-going input threshold voltage: 1.0V typ. Hysteresis Voltage: 0.77V typ.
GP Output	LVTTL with +/- 24mA drive capability	Short-circuit protected.

2.5 Timing Adjustment Ranges

The following tables apply to the **V6414** when the '**SY**' option enabled. The tables show the range of the timing adjustments possible relative to the external reference signal (Synchroniser mode) or the range of adjustable input-to-output delay (also known as insertion delay) if a module is being operated without an external reference, i.e. the incoming video signal itself is used as a 'reference' (Delay mode).

Note that overall insertion delay results from adding these timing adjustments to an intrinsic delay, which is dependent on the mode of operation and the type of conversion (progressive ↔ interlace, video mode ↔ film mode).



Vistek V6414 HD Down Converter

2.5.1 Synchroniser Mode

Standard	Horizontal	Vertical	Field/Frame Delay ('FD' option required)	
			24MB	96MB
1080i59	0 to 29.66 μ s in 13.48ns steps	-256 to +255 lines	4 fields	24 fields
1080i50	0 to 35.56 μ s in 13.46ns steps	-256 to +255 lines	2 fields	20 fields
720p59	0 to 22.24 μ s in 13.48ns steps	-256 to +255 lines	5 frames	25 frames
720p50	0 to 26.67 μ s in 13.46ns steps	-256 to +255 lines	4 frames	21 frames
625i50	0 to 64.00 μ s in 37ns steps	-256 to +255 lines	28 fields	58 fields
525i59	0 to 63.56 μ s in 37ns steps	-256 to +255 lines	34 fields	62 fields

Notes:

- If the 'FD' option is not installed, the extra 'Field/Frame Delay' on top of any horizontal and/or vertical timing adjustments is automatically set to zero.
- If the unit is fitted with the Frame Synchroniser option ('SY') enabled, the hor. and vert. timing adjustments apply to the output video format. The Field/Frame Delay applies to the input video format. This means that a maximum extra delay of just 24 Fields (and not 50!) can be imposed on top of the intrinsic delay when down-converting from 1080i59 to 525i59.

2.5.2 Delay Mode

In the 'Delay Mode', i.e. if the reference is taken from the Input Video signal rather than an external reference, timing adjustments can be accomplished in three levels of accuracy: pixels, lines and fields (interlaced modes) or frames (progressive modes).

Standard	Horizontal	Vertical	Field/Frame Delay ('FD' option required)	
			24MB	96MB
1080i59	0 to 29.66 μ s in 13.48ns steps	0 to 562 lines	4 fields	24 fields
1080i50	0 to 35.56 μ s in 13.46ns steps	0 to 562 lines	2 fields	20 fields
720p59	0 to 22.24 μ s in 13.48ns steps	0 to 749 lines	5 frames	25 frames
720p50	0 to 26.67 μ s in 13.46ns steps	0 to 749 lines	4 frames	21 frames
625i50	0 to 64.00 μ s in 37ns steps	0 to 311 lines	28 fields	58 fields
525i59	0 to 63.56 μ s in 37ns steps	0 to 261 lines	34 fields	62 fields

Notes:

- If the 'FD' option is not installed, the extra 'Field/Frame Delay' on top of any horizontal and/or vertical timing adjustments is automatically set to zero.
- If the unit is fitted with the Frame Synchroniser option ('SY') enabled, the hor. and vert. timing adjustments apply to the output video format. The Field/Frame Delay applies to the input video format. This means that a maximum extra delay of just 24 Fields (and not 50!) can be imposed on top of the intrinsic delay when down-converting from 1080i59 to 525i59.

Vitek V6414 HD Down Converter



2.5.3 Minimum Delay (Intrinsic Delay)

Module	Standard/Conversion	Min. Delay Frame Sync mode	Min. Delay F-Delay mode
V6414	1080i59 to 525i59 (Down Conv.) 1080i50 to 625i50 (Down Conv.)	4 Input Fields + Hysteresis ²	4 Input Fields + T ¹
	720p59 to 525i59 (Down Conv.) 720p50 to 625i50 (Down Conv.)	4 Input Frames + Hysteresis	4 Input Frames + T ¹
	525i59 to 525i59 (Bypass) 625i50 to 625i50 (Bypass)	4 Input Fields + Hysteresis	4 Input Fields + T ¹

Notes:

1. $T < 70\mu s$
2. $9.1\mu s$ (min) $24.4\mu s$ (max) Hysteresis = $15.3\mu s$

2.6 Hardware

2.6.1 The PCB

The figure overleaf shows the construction of the PCB, along with some components of interest. Note that the main I/O connector is in fact mounted on a daughter board, which is held down by two screws. The V6414 Converter also has a large sub-board mounted on the centre of the board.

The main connector is a 220-way 2mm press-fit connector. When new there may be a substantial insertion force when mating with a rear module; this is normal. However, it is important that the module is not plugged into one of Vitek's conventional units with significant force. If so then it is possible to break off one of the locating lugs.

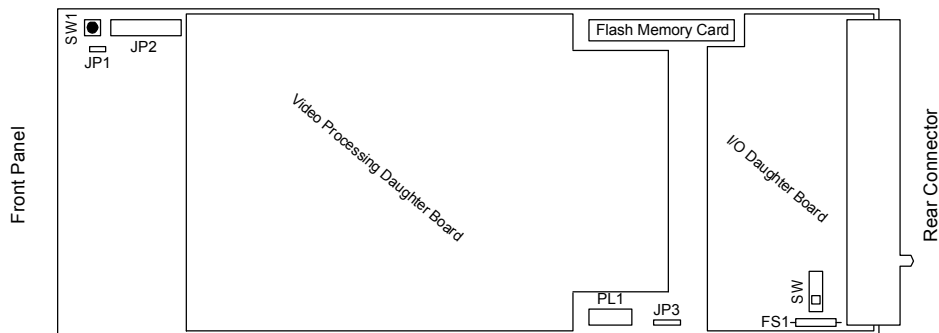



Vistek V6414 HD Down Converter

2.6.2 Links and Switches

The purposes of the links and switches are shown in the following table. Details of their operation are described in later sections.

ITEM	Title	Comments
SW1	RESET	Used to reset the internal microcontroller.
JP1	Debug	For development and test use only. (May not be fitted)
JP2	H8 Program	For development and test use only. (May not be fitted)
PL1	JTAG Port	Never used in operation. (May not be fitted)
JP3	JTAG Enable	For Test. Fit in 2-3 position.
SW	Video REF Term	Slider up – Terminated with 75Ω Slider down – Hi-Z (un-terminated)

2.6.3 Fuse

There is only one fuse on this module, which is in series with the main DC supply input.

FS1	Fuse 2 Amp Wire ended	In series with the +15V input to the module on the I/O daughter board.
-----	-----------------------	--

2.6.4 Flash Memory Card

The Flash Memory Card stores the firmware for the Microcontroller and the FPGA and is essential for the operation of the module. If this card is missing, the front panel display will come up with an error message (ERROR 10). The Flash Memory Card sits in a socket with a location peg to the right. In case of a firmware upgrade, one has to make sure that the replaced card sits firmly and straight in the socket with the location peg mating with the positioning hole on the baseboard.

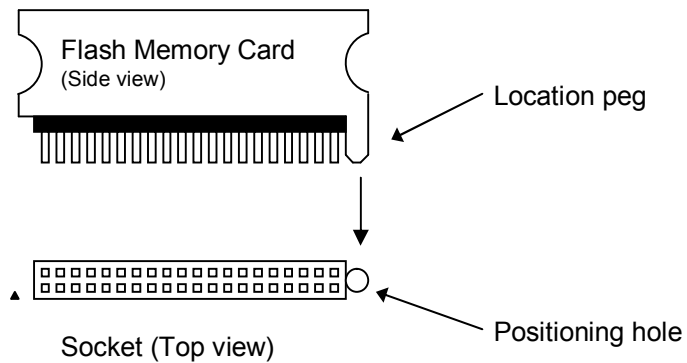

The Flash Memory Card is re-programmable. Customers are kindly asked not to throw it away after having upgraded a module with a newer firmware version. A Vistek service technician will collect it on his/her next visit or it can be put in an envelope and sent back to the postal address shown on the cover of this manual.

2.7 Front Panel



The front panel is similar to other complex V1600 types. It provides the user with total control and monitoring of the unit without the need to consult manuals and read unlabelled indicators.

At first use the menu system may seem cumbersome but with only a small amount of practice it will become very easy to use.

2.7.1 Direct Indications

The four LEDs at the top of the panel provide these direct indications of the unit::

- | | |
|-------|---|
| REM | Short blinks to indicate access by the DART controller, if fitted. It does not directly indicate that the unit is in remote control mode. If the rack frame does not have a Rack Controller fitted then this LED will not blink. |
| +V | Indicates that the main +3.3V is present on the board. This is derived from the +15V distributed through the rack. The modules do have many power rails, but only the main +3.3V is indicated here. It will, of course, be off if the fuse, FS1, were to have been blown. |
| HD/SD | Indicates that a valid SDI signal (either HD or SD) is being received. |
| REF | Indicates that a valid video reference signal is present – either bi-level or tri-level. |



2.7.2 Display and Switches

The main display is an eight character LED matrix display. It has been set so that when fitted into a 3U rack (V1606) it can be read from the left, and when fitted into a '1-Box' (V6011) it is horizontal and the 'proper' way up. (At time of writing it is not possible to fit the V6414 HD Down Converter into the V1602 1U rack!)

The three action buttons are labelled **Select**, ▲ and ▼. The **Select** button is used to move down and up the menus. A short press will move down one level, while pressing and holding for about half a second will move up one level. If you continue to hold it will progressively move up a level every half second until it reaches the top level (**SLEEP**), or you let go, in which case it will stay where it is. When at any level the ▲ and ▼ buttons will move through the list of options, or if in an actual variable (such as Video Gain) they will change the values.

If the unit is in Local control then the display and switches are used to set up and show the operation of the module. If in remote mode, they are still active for showing the status but cannot be used to actually change parameters.

Beside the ▲ and ▼ buttons are three LEDs marked +, **CAL** and -. In general the **CAL** LED is used to show that a variable is set to its normalised value and if not then the others show in which direction it has been changed or that it is no longer on its CAL value.

2.7.3 Remote/Local Control

The lowest switch selects between Local control and Remote control over DART:

- | | |
|-------|---|
| Local | Control is from the front panel itself. |
| Rem | Control is from the DART system. This requires the use of an external controller running a suitable programme, which communicates with multiple racks using the Dartnet protocol. |



3 System Operation

3.1 Local Control

3.1.1 Start Up

Local control and monitoring of the module is done through the front panel with its eight character LED display and three control buttons **Select**, **▲** and **▼**. There are three LEDs which also contribute to the status indication; these are labelled **+**, **Cal** and **-**.

After power up and having successfully passed the power-on-self test, the display will start at the top level and show the unit type and any options that are included. The display will be one of these:

Unit type	Password protected Option(s)
V6414	VP, SY, SV, FD, AH, CP

If the last character shown is a '+' (e.g. **v6414sv+**), this indicates that the unit has further options installed. To see what they are, use the **▼** button to navigate.

3.1.2 Option Abbreviations

Options are indicated by abbreviations. The following list illustrates their meanings:

Option	Meaning
VP	Video Proc Amp
SY	Frame Synchroniser
SV	Frame Synchroniser + Video Proc Amp
FD	Field/Frame Delay (requires either SY or SV option)
AH	Audio Handling
CP	Closed Captioning



3.1.3 Menu Control

The **Select**, ▲ and ▼ buttons are used to manoeuvre around the menu system. The menu structure has five levels and the **Select** button is used to go up and down the structure. The ▲ and ▼ buttons are used to move between selections or to adjust a parameter depending on which sort of menu is displayed. The five levels are as follows:

Sleep	Display is blank (except for Banner warnings).
Top Level	As above, e.g. V6414FD
Main Menu	The Main menu items, such as VIDEO , STATUS , ENG'ING etc. These items are all in Upper Case.
Sub Menu	Menu items under each main heading, such as Source or A/R under the VIDEO main menu. These items are all in Sentence Case (generally lower case but with upper case first letters).
Parameter	The lowest level under the Sub Menu, and used to actually adjust a parameter. The display will depend on the actual parameter and may be a value such as +0.00dB for a gain or ON or OFF for a switch variable. There is usually a title to describe the variable and a small icon in the left hand character position, but 8 characters cannot provide for a detailed description.

To move down a level just press the **Select** button briefly; then press either the **Select** button again to go down another level or the ▲ and ▼ buttons to move around the options within a level.

To move up a level press and hold the **Select** button for about half a second which will move up one level. If you continue to hold the **Select** button then it will move up a level every half a second until it reaches the Sleep level (one above the Top Level).

A complete list of all the menus is given in Section 5.

3.1.4 Menu Examples

This section has examples of how to manoeuvre through the menu system. The first one starts with the unit in its 'sleep' mode where the display is blank, and then proceeds to set the reference source to the processing input (*Vid I/P*).

Action	Display	Comments
Select	V6414SV	Top Level
Select	VIDEO	The Main Menu we want
Select	Source	The first Sub Menu in the list
▼	A/R	
▼	Ref Src	The Sub Menu we want
Select	Auto	The default setting
▲	Vid I/P	Set it as we want it



Vistek V6414 HD Down Converter

Now we shall select how the unit behaves when the input fails. The following steps should be taken from the current position (Select+Hold means that you should press and hold the select button for about half a second):

Action	Display	Comments
Select+Hold	Ref Src	UP to the Sub Menu level
▼	Anc Data	
▼	VFL Mode	The Sub Menu we want
Select	Black	The default setting
▲+ Hold	1 sec	Unit automatically counts up till it comes to...
	Freeze	or do you want it to go 'Black' after 14 sec?
▼	14 sec	Set it as we want it

3.1.5 Sleep

If the front panel is not used for a certain amount of time then the display will automatically go into a sleep mode when it will be blank. Pressing any of the buttons will cause it to 'wake up' back into the top level. The time delay before the unit slips into sleep mode can be set up using the **ENG' ING : Sleep** menu.

The brightness of the display can also be adjusted using the **ENG' ING : LEDLevel1** menu.

3.2 Core Product Features

3.2.1 SDI Inputs

The SDI inputs must conform to either the SMPTE292M or SMPTE259M standards, which describe the Bit Serial Digital Interface for HD and SD operation. If only one input is required then it should be connected to SDI 1. Unused inputs can be left open, it is however recommended to terminate unused inputs with a 75Ω Terminator to improve noise immunity. Signals of different frame-rates, resolutions or even a mixture of SD and HD standards can be connected to both Inputs at the same time, however only one of the two inputs can be selected at a time. Note that switching between different standards is neither instant nor glitch-free. This has to do with the necessity of the SDI de-serialiser hardware to lock to the newly detected standard. Furthermore, in case of an SD-to-HD switch over (or vice versa), the FPGA on the baseboard must be re-loaded. This process takes about 2 to 3 seconds.

The input selection is done on the **VIDEO : Source** menu.

3.2.2 SDI Reclocked & Buffered Output

This is always available, and is a reclocked version of either SDI 1 or SDI 2, depending on the source selection. It is an unprocessed signal, i.e. neither synchronised nor converted.



3.2.3 SDI Main Outputs

The main synchronised/processed SDI output is available on two BNCs.

3.2.4 Video Reference

The external video reference is available for units with the Frame Synchroniser function; it can be either a standard composite black and burst video signal, or a new style tri-level sync. The unit will automatically detect which and extract the relevant timing information.

Note that on V6414 unit the SY function is optional. If it is not enabled, the Video Reference Input has no function.

The reference is looped on the rear module so it can be daisy chained along several modules. For accurate timing, this is not recommended. There is a termination on the I/O daughter module, which can be switched in at the end of the chain. Care should be taken to ensure that each reference has only one termination set.

The units can operate from either the external reference or use the selected SDI input. This is selected on the **VIDEO : Ref Src** menu. When set to *Auto*, the external reference will be used if available; otherwise the selected SDI input will be used as the reference.

3.2.5 Standard Detection

The units detect and report back the detected video standard and frame-rate of the selected SDI input and that of the reference input. The detected standard can be seen in the **STATUS** menu under **I/P Std** and **Ref Std**.

3.2.6 TRS Signals

The TRS signals are the digital equivalent of the analogue synchronising pulses. All modules described in this manual always regenerate the TRS signals on their output, so that any errors on the input signal will not be propagated through.

3.2.7 EDH (SD operation only)

EDH is a method of embedding data within the ancillary data space that carries a measurement of the integrity of video and other data. By regenerating the equivalent measurement at the receiving end it is possible to check that the data has been received correctly.

HD signals always have the EDH data in form of checksums embedded, but for SD signals it is optional. On the V6414 Down Converter the EDH on the output can be disabled on the **ENG' ING : O/P EDH** menu. Care must be taken if the new EDH generation is disabled and the old EDH is being passed through because it will probably not correctly represent the data. In this case the Ancillary Data really ought to be blanked.



Vistek V6414 HD Down Converter

3.2.8 Illegal Codes

A function of these modules is to ensure that the SDI output always meets the relevant specification. In particular this means that the output is always legal in the sense of Line Length, Field Length and data values. In the main this works extremely well, but there are some circumstances where it fails:

- If the output timing is being changed, there will be momentary errors.
- If the input is noisy, such that erroneous data is received, then the ancillary data may get checksum errors. This obviously only applies if the Ancillary data is being passed. The video will be all right, since the EDH (SD operation), respectively the line numbers and CRC codes in accordance with SMPTE 292M (HD operation) are regenerated on the output.
- If the reference is unstable or changing standards then the output will not be stable.

3.2.9 Horizontal and Vertical Blanking Interval Data

V6414 in Down Conversion mode:

Provided that the V6414 Down Converter unit is fitted with the Audio Handling (AH) or Closed Captioning (CP) options, relevant chunks of Ancillary data, such as embedded Audio or Closed Captioning, can be transferred from the Input standard to the selected Output standard.

V6414 in Standard definition input to output 'Bypass' mode:

Any data embedded in the horizontal and vertical blanking intervals can be retained throughout the Frame Synchroniser stage. Ancillary Data can be passed unchanged (`VIDEO : Anc Data 0 Anc Pass`) or it can be set to 'Black' (`VIDEO : Anc Data 0 Anc Blnk`).

3.2.10 SDI Input Fail

V6414 with SY option:

If the selected SDI input fails, then the output picture will be either frozen, set to black or the selected input will switch from input 1 to input 2 (`VIDEO : VFL Mode`). If the Frame Delay option is not installed or set to zero, the output will resume after a full frame of undisrupted video has been received. On units with the Frame Delay option installed, resumption of the 'live' output will be delayed by the number of Frames set in the `VIDEO : F Delay` menu.

V6414 without SY option:

If the selected SDI input fails, then the output picture will be frozen. The output will continue after a full frame of video has been received.



3.2.11 Video Reference Fail

V6414 with SY option:

When there is no external reference signal present, the unit will use the selected SDI input as its timing reference if **VIDEO : Ref Src** is set to *Auto*. If **VIDEO : Ref Src** is set to *Ref I/P*, the module continues operating in a free-run mode if the external reference is invalid or absent.

Under the circumstances described above and depending on the setting of **VIDEO : RFL Mode** (**Reference Fail Mode**), the module then switches automatically into a minimum delay mode (*Min Dly*) or it maintains the delay set by the F-, V- and H- Delay controls (*Adj Dly*).

A module can be also forced to use the SDI input as its timing reference by setting **VIDEO : Ref Src** to *Vid I/P*. In this case, the current setting in **VIDEO : RFL Mode** will be ignored and the total insertion delay simply depends on the current settings in the F-, V- and H-Delay controls.

3.2.12 GPI Configuration

The V6414 has one GPI input available on the rear panel assembly, via a BNC connection.

Connecting the input to 0v activates the GPI; leaving it open circuit de-activates it. The status is shown in the **STATUS : GPI** menu as **GPI ↑** or **GPI ↓**, the former being active and the latter inactive (despite the fact that connecting it to 0v makes it active).

The GPI function can be set-up in the **CONFIG : GPI** menu to control the input selection, or switch the module's output to an internally generated 75% colour bars test signal. The 75% bars output option will only function with the **SY** option fitted.

Note that, if Video fail mode is set to "switch to I/P 2", the GPI can be used to set the source back to I/P 1 after the signal is restored. If the GPI is set to SDI1, it can be activated either permanently or momentarily. If it is set to SDI2, a momentary activation resets the source back to I/P 1.

3.2.13 Video Reference Mismatch

When a mismatch between the Video Input's (*Vid I/P*) frame-rate and the Reference's frame-rate is being detected, the output can either follow the *Vid I/P* or the Reference, depending on the setting of **VIDEO : XStdMode** (also known as 'Cross-Reference' mode).

Available options are:

XStd Ref: Output frame-rate is set to Reference frame-rate, no matter what the Video Input frame-rate is.

XStd I/P: Output frame-rate is set to Video Input frame-rate.



Vistek V6414 HD Down Converter

V6414 Example: Vid I/P is 720p @ 59.94Hz

XStdMode is set to *XStd Ref*

Ext. Reference changes from 59.94Hz to 50Hz

⊖ Output frame-rate instantly changes to the Reference frame-rate, i.e. the Output standard will be 625i @ 50Hz thereafter. The Output picture will look somehow corrupted - which is absolutely normal - but the Output video timing fully complies with the 625i50 standard. The reader should be reminded here that the V6414 cannot perform frame-rate conversions (e.g. 59.94Hz to 50Hz).

The Frame Synchronizer will automatically resume normal operation as soon as a frame-rate match has been re-established.

3.2.14 Delay Signal

The Frame Synchroniser produces a signal that represents the variable delay being inserted into the video path. This delay information is passed on internally to the V6302 Advanced Audio Processor (if present) and used to provide a tracking delay to the audio. The signal is also available externally so it can be used by other audio tracking devices. Please note that the length of the tracking delay pulse is a measure for the variable delay between input and output only – it does not cover for any additional Field/Frame-Delay added on top of the variable delay.

The Delay signal has repetition rate of two frames and the positive pulse width represents the variable delay. This is shown in this diagram.

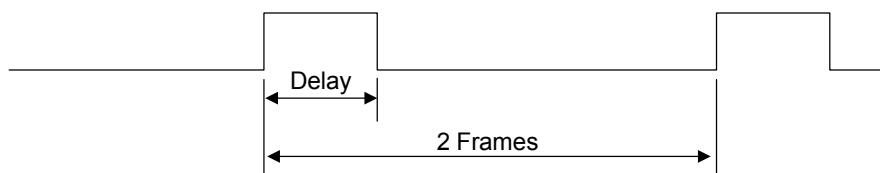

If the unit is not synchronising, such as loss of I/P or Freeze, then the delay output is blanked (static low). It is expected under these conditions that the audio processing will hold its current delay from the last valid measurement until a pulse re-appears.

The external Delay Pulse output is available on a BNC on the rear panel. The external pulse itself is nominally 3.3V with a sourcing/sinking capability of $\pm 24\text{mA}$.



3.2.15 VCO Centre Frequency

Normally, the output is locked to the video reference - if present - and of the same standard as the video, or to the input video itself. If there is no signal or reference connected then the output will free run at the nominal centre frequency of the on board clock generator. This centre frequency can be adjusted under the **CALIB : CntrFreq** menu, but this should not normally be necessary in the field.

It is possible to force the unit into its free-run mode using the **ENG' ING : Free-run** menu. This is an unusual requirement and so is a setting that appears on the top level banner when set.

3.2.16 Version Numbers

The V6414 module comprises various items of software/hardware and they all have separate version numbers. These can be read on the following read only menus:

STATUS	Soft Ver	XX.XX.XX	Microprocessor Code
STATUS	FPGA Ver	XX.XX	FPGA (Cyclone) Code
STATUS	CPLD Ver	XX.XX	CPLD Code
STATUS	PCB Ver	XX.XX	The PCB revision, with Mod status
STATUS	Strx Ver	X.X.X	Stratix device Code
STATUS	Boot Ver	XX.XX.XX	Boot Loader

3.2.17 Memory Size

The amount of SDRAM fitted on the baseboard can be checked in the read only menu **STATUS : Mem Size**. Some module functions, such as the Field/Frame Delay option, are memory size dependent. Currently, modules are available with two different memory configurations:

Memory Size	Supported Features
24MBytes	Basic – with limited Field/Frame Delay functionality
96MBytes	Required for full Field/Frame Delay support

3.2.18 Display Sleep

Since, for the vast majority of its life, a module will operate behind the front panel of a rack frame, the display on the local front panel will not be visible so it will go to sleep after a certain time. This timeout delay can be changed on the **ENG' ING : Sleep** menu to be anything between 0 and 30 minutes; 0 minutes means that it will stay on indefinitely. The sleep timeout always counts from the last front panel button push. The default time is 5 minutes.

The panel can also be forced into its sleep mode by moving up a level from the Top Level menu, which displays the module type.

To get the display to come on again simply press one of the buttons and the menus will start again at the Top Level.



Vistek V6414 HD Down Converter

3.2.19 Display Brightness

The brightness of the front panel display can be adjusted on the `ENG' ING : LEDLevel` menu.

`ENG' ING LEDLevel █ █ █ █`

3.2.20 Conversion Modes

Input Modes:

By default, an auto-sensing mechanism switches the board between SD or HD input modes, depending on the Input standard applied to the board and the selected output standard.

Alternatively, the board can be 'forced' to work either in SD or HD input modes. In order to do this, go into the `CONFIG : SD/HD Op` menu. The three available options are: *Auto*, *HD* and *SD*:

'Auto', as the name implies, enables the auto-sensing mode. Changing the Input Standard from 525i59 to 720p59 for example will prompt the Microcontroller to re-load the FPGA automatically.

'HD' will force the board to permanent HD input operation.

'SD' will force the board to permanent SD input operation.

Permanent SD or HD operation might prove to be useful in installations where:

- the infrastructure is fixed to SD or HD anyway
- operation in 'noisy' environments
- a lot of Input Standard switching is going on (within one group of Standards)

Forcing the board's operational mode to either SD or HD will prevent it from unintentionally re-loading its FPGA code due to false interpretation of the detected Input Standard.

3.2.21 Down Converter Aspect Ratios

A Down-Converter always converts a 16:9 input picture to a 4:3 aspect ratio output. The V6414 gives four options in the **VIDEO : A/R** menu. They are shown diagrammatically below. Note that some conversion settings result in a loss of parts of the original picture (indicated by hatched areas).

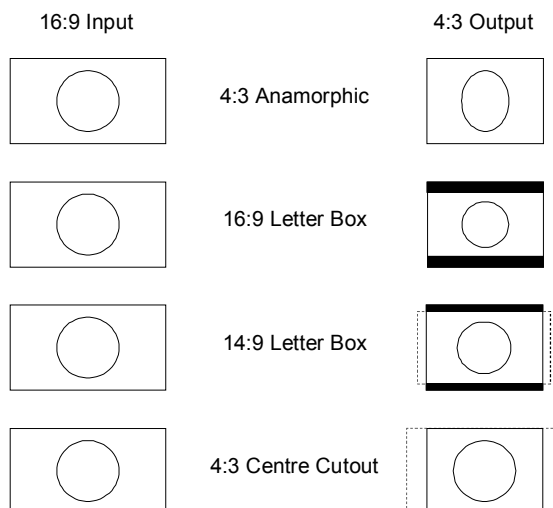

3.2.22 Horizontal Resolution

ENG' ING H Res

There are three settings for horizontal picture resolution: high, medium or low. The normalised setting is high.

Please note that the horizontal picture resolution control is active only when converting between high definition inputs and standard definition outputs.

3.2.23 Vertical Resolution

ENG' ING V Res

There are three settings for vertical picture resolution: high, medium or low. The normalised setting is high.

Please note that the vertical picture resolution control is active only when converting between high definition inputs and standard definition outputs.

3.2.24 Bypass Delay (Standard Definition)

ENG' ING Byp Dly

If the input to the unit is of standard definition format, the signal is 'bypassed' to the output without any format conversion. Under these conditions the Bypass Delay control may be used to define the insertion delay of the signal through the unit. The two choices are:

Delay compensation (**Dly Comp**) mode matches the delay through the unit when down converting (4 fields). This is the normalised setting for this control.

Minimum delay (**Min Dly**) mode reduces the insertion delay of the signal through the unit to less than one line (zero fields delay).



Vistek V6414 HD Down Converter

3.2.25 Motion Adaption

ENG'ING Mot Adpt

The V6414 HD down converter incorporates a motion adaptive de-interlacing algorithm, which continually, and pixel by pixel, modifies the operation of the unit between a 3 field aperture (best for static images) and a single field 'intra' field mode (essential where there is movement).

If desired, the motion adaptive control signal may be switched off using the above titled control, forcing the de-interlacer to operate in single field mode:

Mot Adpt Adpt On Motion control signal on. Normalised position.

Mot Adpt Adpt Off Motion control signal off. Single field (motion) mode.

3.3 Frame Synchroniser and Field Delay Options

3.3.1 Manual Freeze

V6414SY

The output picture can be frozen manually using the VIDEO : Freeze menu.

With interlaced video input formats, such as 1080i59, the operator has the choice between *Field1 - Field2 - Frame*. Please note that when freezing a field, the selected field will be used for displaying both fields, resulting in a simple line-doubling effect. When freezing an interlaced input as 'Frame', the frozen image may appear very fuzzy or shaky, depending on the amount of motion between field1 and field2.

With progressively scanned input formats, the same choices are available, but a Frame-Freeze actually happens when selecting any of the three options (*Field1 - Field2 - Frame*).

When using the manual freeze function in connection with the Field/Frame Delay option, resumption of normal operation after a freeze will be delayed by the same number of frames (or fields) as set in the F-Delay menu.

The reason for that is that after having sent the *Run* command, the frame buffer must be filled first with n-frames in order to maintain the delay as set in the F-Delay menu.

At HD operation, this 'resumption-delay' is almost not noticeable, even if the frame-delay is set to a maximum. At SD operation however, the delay can be up to 2 seconds!

3.3.2 Timing & Delay Control

3.3.2.1 With External Reference (Ref I/P)

V6414SY

The delay imposed on the SDI data processed by a frame-synchronising module depends first of all on the Reference Source selection. If an external, analog Reference signal (e.g. Bi- or Tri-Level Sync) is present and the **Ref Src** selection control (VIDEO : Ref Src) is set to *Auto*, the V6414 will automatically operate as a Frame-Synchroniser, which means that its output will be frame-synchronous to the Reference signal applied.

Vistek V6414 HD Down Converter



In order to keep pace with the incoming SDI data, the Frame-Synchroniser will either repeat a frame or drop a frame once in a while, depending on a) which of the two clock domains (Input Video versus Reference signal) is the faster, and b) how far the two clock domains are apart (typically in the range of 0 to ± 150 ppm).

Between the events of two successive frame repeats, respectively two frame drops, the input-to-output delay will gradually increase (or decrease) from a variable minimum value (hysteresis) up to one frame (or vice versa). Hysteresis is essential in order to prevent a series of frame drops or repeats when approaching the 'roll-over' point.

As explained earlier, an extra n-field/frame delay can be introduced on top of this variable delay if the 'FD' option is enabled.

When operating the V6414 as a Frame-Synchroniser, two timing controls (V- & H-Timing) are available for adjusting the board's output timing relative to the external Reference signal. This works irrespective of the additional Field/Frame delay, which can be applied on top of the inherent variable delay.

- | | | |
|--------------------------|----------|---|
| VIDEO : V Timing: | Purpose: | For vertical adjustment (in number of lines) |
| | Range: | -256..+255 lines |
| VIDEO : H Timing: | Purpose: | For horizontal adjustment (micro seconds) |
| | Range: | 0 μ s up to one line (one pixel resolution) |

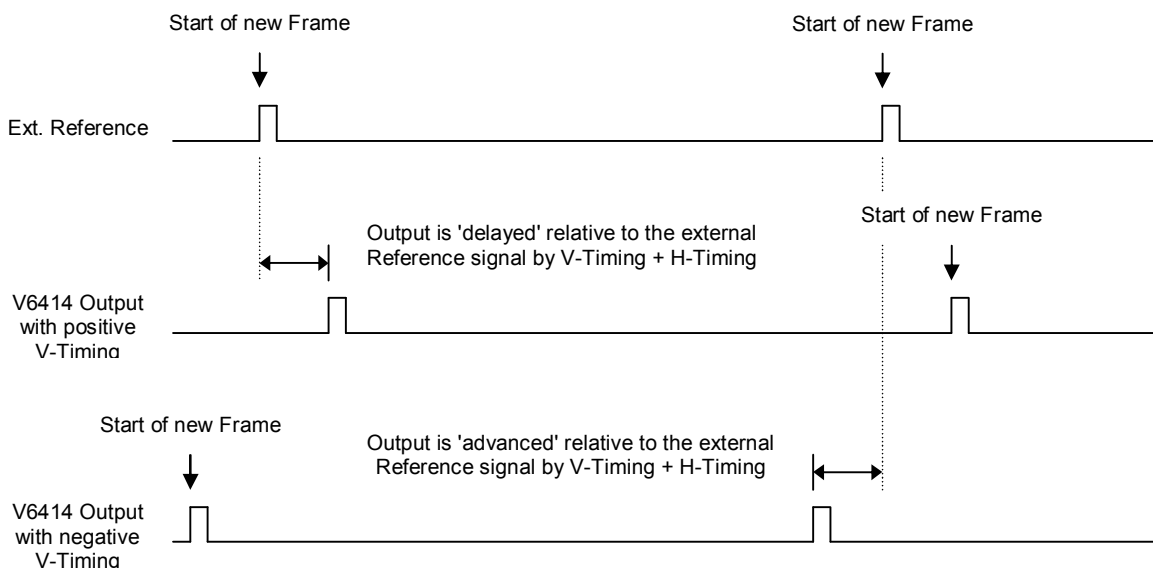

This drawing illustrates the **Reference-to-Output** timing relationship when operating a V6414 in its Frame-Synchroniser mode.

Note that the Input-to-Output delay in a Frame-Synchroniser is variable and spans from a minimum delay up to a complete Frame. This timing variation can be monitored with a scope on the Delay Pulse BNC.



Vistek V6414 HD Down Converter

3.3.2.2 With Internal Reference (Vid I/P) V6414SY

Alternatively, the V6414 can be used as a straightforward, adjustable Field/Frame Delay module, in applications where for example the incoming SDI signal is already frame-synchronous but requires an arbitrary delay in order to compensate latency accompanied with the encoding of specific Audio formats.

Disconnecting the external Reference signal (in case VIDEO : Ref Src is set to *Auto*) or forcing the unit to take its Video Input as the Reference signal (VIDEO : Ref Src is set to *Vid I/P*) will automatically disable the Frame Synchroniser function and put the board into a pure delay mode.

The V- and H-Timing controls change their meanings into V- and H-Delay. If the F-Delay option is enabled, an extra n-Field(s)/Frame(s) delay can be imposed on top of the V- and H-Delay.

F Important:

If VIDEO : Ref Src is set to *Auto* and no external Reference signal is present, the unit assumes that there is a persistent problem with the external Reference and the actual insertion delay is controlled by the setting in the VIDEO : RFL Mode menu:

If RFL Mode is set to *Min Dly*, all delay control settings will be forced to zero and the unit continues operating in a minimum delay (= intrinsic delay) mode.

If RFL Mode is set to *Adj Dly*, the insertion delay is the sum of the unit's intrinsic delay plus whatever is set in the F-, V- and H-Delay controls.

VIDEO : F Delay: Purpose: Coarse delay (in number of fields or frames)



(Password enabled Option)

Range: depends on baseboard configuration and Input Standard

VIDEO : V Delay: Purpose: Fine delay (in number of lines)

Range: 0 up to (number of total lines per field/frame – 1 line)

VIDEO : H Delay: Purpose: Super fine delay (in microseconds)

Range: 0µs up to (duration of one line – one pixel)

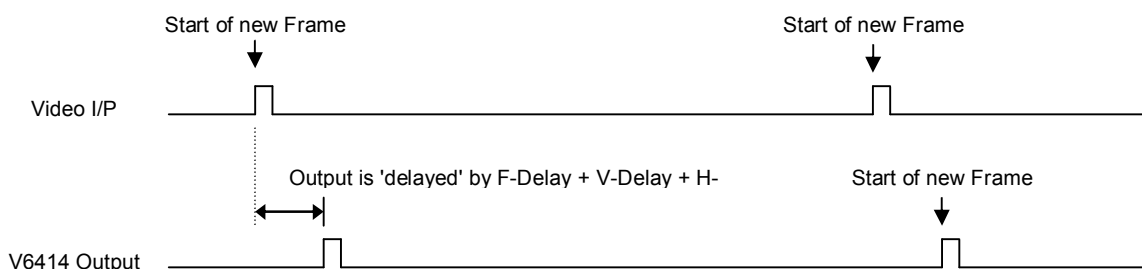

3.3.2.3 Field/Frame Delay (FD) Option

V6414FD

To check whether the module is fitted with the 'FD' option, go into the **STATUS** menu and see under **option** what options are fitted. If 'FD' is shown (might be shown together with other installed options), the board can be used as an adjustable Field/Frame Delay.

In addition to the variable delay, which is inherent when operating as a Frame Synchroniser, an extra n-Frame(s) (progressive input) or n-Field(s) (interlaced input) delay can be added on top of the variable delay.

When operating the module without an external reference, an extra n-Field(s)/Frame(s) delay can be added on top of the adjustable V- and H-Delay (see previous section for details).

The maximum amount of extra delay depends on the Baseboard's frame store size (24MB or 96MB) and the current Input Standard. To find out how much memory is fitted on the Baseboard, go into the **STATUS** menu and check under **Mem Size**.

The two available Baseboard configurations are: 24MBytes or 96MBytes.

The following table shows the upper limits of the Field/Frame Delay control (**VIDEO : F-Delay**). Please note that the actual numbers displayed in the menu **F-Delay** represent 'Fields' if the input standard is interlaced and 'Frames' if the input standard is progressive:

Input Standard	Maximum Delay ²	
	24MB Frame store	96MB Frame store
1080i59	4 fields	24 fields
1080i50	2 fields	20 fields
720p59	5 frames	25 frames
720p50	4 frames	21 frames
525i59	34 fields	68 fields ¹
625i50	28 fields	58 fields ¹

Note 1:

An extra fixed delay of 1 second can be added on top of the 50/60 fields by setting the **DELAY** option in the **ENG' ING** menu to '1 Second'. This option is only available if the Baseboard is fitted with 96MBytes of memory.

Note 2:

The **Maximum Delay** values specified in this table apply for video delay only, if the FD option is used in conjunction with the AH (Audio Handling) option, the following rules apply:

96MB FrameStore: In order to maintain the timing relationship between video and embedded audio, the maximum Field/Frame delay numbers listed are reduced by 4.

24MB Frame Store: Audio delay compensation is not supported on 24MB boards.



Vistek V6414 HD Down Converter

In terms of the actual delay imposed, same numbers imply the same delay in milliseconds, provided that the field/frame rate is the same. Example:

Input Std. is 720p59, F-Delay is set to 4 (frames): Output is delayed by 66.7ms (+ V-Delay + H-Delay)

Input Std. is 1080i59, F-Delay is set to 4 (fields): Output is delayed by 66.7ms (+ V-Delay + H-Delay)

The following illustration shows how the Field/Frame Delay works:

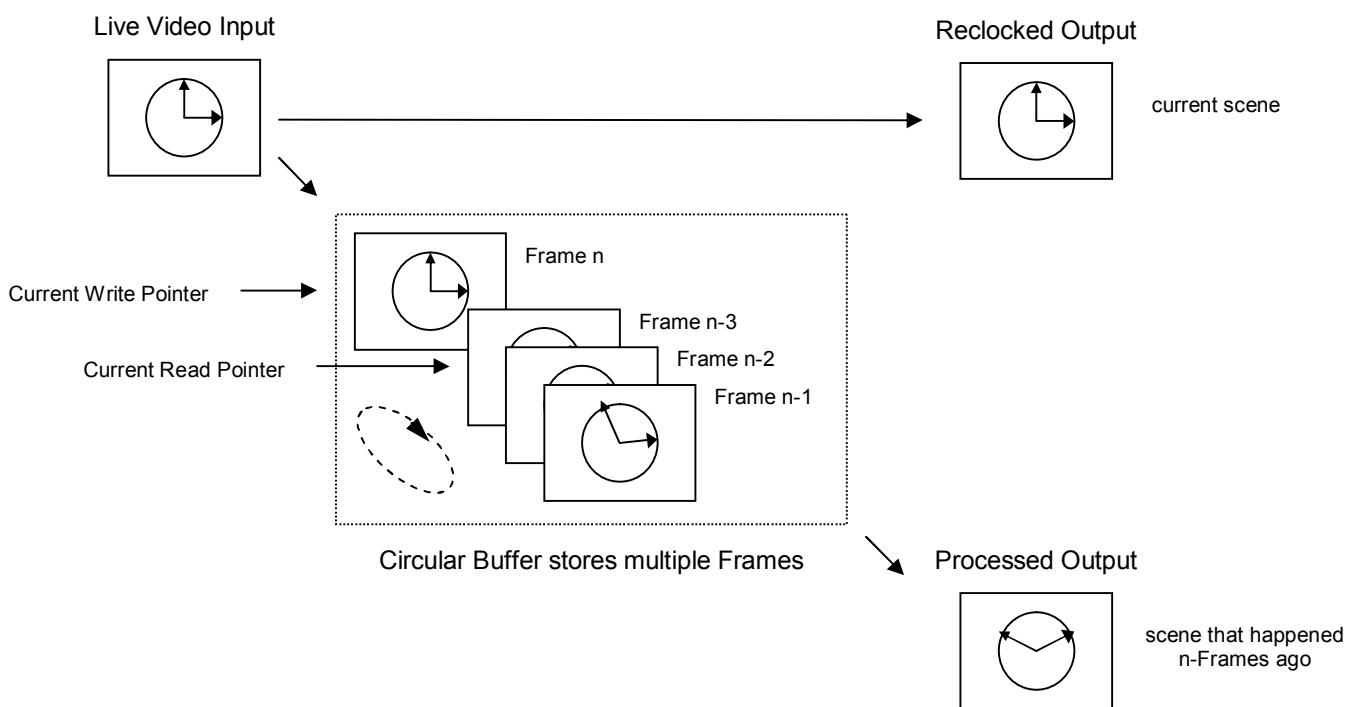

Live Video data gets written into a circular buffer (Frame-Store), which is $n+1$ frames deep (n is the number of frames the output gets delayed on top of the variable delay). The buffer's write-pointer lags exactly one frame behind the buffer's read pointer, which means that a frame that got written n -frames ago, will be read one frame prior to it gets overwritten by a new frame.

If the input standard is interlaced, the output can be delayed on a 'per-field' basis by shifting the output timing by one field (field1). The field order will remain intact.

3.3.3 Test Pattern Generator (TPG)

V6414SY

The V6414 with the SY option fitted comes with a built-in Test Pattern Generator (TPG). The test patterns can be used to provide signals for system testing and even for testing other pieces of equipment. All test patterns are generated 'on-the-fly' and do not interfere with the current contents of the Frame Buffer. Clean switching between test patterns and the selected live video input is also provided.

On the V6414, test patterns are being generated on the 'Input' side to the filtering and scaling processor, which means that they can be used to verify the conversion process.

The vertical interval is considered to be a part of the test pattern and is always synthesised as Black. This means that the vertical blanking interval is always blanked when Test Patterns have been selected. The same applies to Ancillary Data in the horizontal blanking interval.

The actual TPG selection menu can be found in the 'Engineering' Menu (**ENG'ING : Test Ptn**):

The default setting in the **Test Ptn** sub-menu is: *TPG Off*

From the remote control system they can be called up directly.

From here you have a choice of up to 7 built-in test patterns. Test pattern No.7 is a 'reserved' or a custom Test Pattern and might change between different firmware versions. At the time of printing, it is set to 'Black'. Note that the 100% and 75% colour bars have limited transition rates between adjacent bars. Stepping through the menu, the following Test Patterns will be generated:

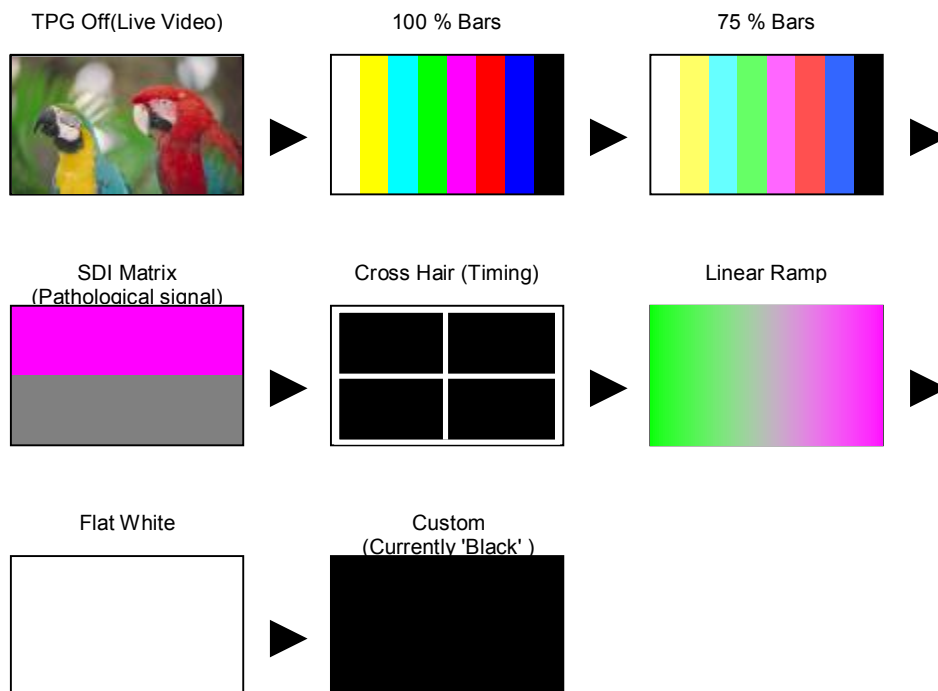



Vistek V6414 HD Down Converter

The V6414 can be used as a simple stand-alone TPG, without the need for an Input signal or Reference signal being present. If the module powers up without an Input signal present, its output will automatically switch to the SD or HD Standard according to the selection made in the **CONFIG:Def Std** menu.

The Output Standard can be changed 'on-the-fly' by stepping through the **Def Std** menu. The Output Standard will instantly change to the selected mode without changing the selected test pattern. Please note that some Broadcast- or Professional-Monitors cannot cope with progressive standards with frame-rates of less than 50Hz, i.e. it is not surprising if no picture appears on the Monitor when selecting the 1080p25Hz or 1080p29Hz mode for example. A Waveform Monitor, such as Tektronix's WFM700 can be used instead for monitoring these standards.

As soon as a valid Video Input signal is present, the output will follow the detected Input Standard. The Output Standard can no longer be changed by flicking through the **Def Std** menu thereafter. Even when the Input signal gets disconnected, the Output will remain in the 'last known good' mode. However, it can be overwritten by changing to a different Input Standard. Only a Hardware Reset (or re-powering the module) brings the Output Standard back to the Default Standard selected in the **Def Std** menu, provided that no Input signal is present at the time of carrying out a manual Reset or re-powering the module.

If a test pattern is selected (**ENG:ING:Test Ptn:Bars 100** etc.) and the unit gets switch off, it will reboot next time with this last selected Test Pattern and the last selected Default Standard.

3.4 Video Processing Amplifier

V6414VP

3.4.1 Video Gain

PROC AMP V Gain

The adjustment range is $\pm 6\text{dB}$ and it applies equally to the luminance and both of the chrominance channels (Cb and Cr). The gain is applied after the black level offset. The Video gain is applied simultaneously with the Chrominance gain so they can cancel one another out. For example +3dB of Video gain along with -3dB of Chroma gain will result in the luminance being increased by +3dB and the Cb and Cr channels being unchanged.

The output is limited to ensure that there is no numerical overflow as the output fits into the 10 bit D1 domain. There is no gamut legalisation function.



3.4.2 Chroma Gain

PROC AMP C Gain

The adjustment range is ± 6 dB and it applies equally both the chrominance channels. The gain is applied along with the video gain and after the black level offset. The Chrominance gain is applied simultaneously with the Video gain so they can cancel one another out. For example +3dB of Video gain along with -3dB of Chroma gain will result in the luminance being increased by +3dB and the Cb and Cr channels being unchanged.

The output is limited to ensure that there is no numerical overflow as the output fits into the 10 bit D1 domain. There is no gamut legalisation function.

3.4.3 Black Level

PROC AMP Blk Lvl

The adjustment range is -127 and +128 D1 levels (equivalent to -101/+102mV). The black level adjustment is applied before the gain stages. This is considered the best arrangement since the unit is usually used to correct incoming errors.

3.4.4 Hue Shift

PROC AMP Hue

The adjustment range of the hue shift is $\pm 45^\circ$ in 0.35° steps.

3.4.5 Dynamic Rounding

PROC AMP Dyn Rnd

Since some quantising effects may be visible on the output of this unit when variable gains are applied, Dynamic Rounding has been applied. This Dynamic Rounding is only used to reduce the effects of the fractional bits of lower significance than the normal 10 bits; it does **not** reduce the resolution to 8 bits.

This can be disabled on the PROC AMP : Dyn Rnd menu.



Vistek V6414 HD Down Converter

3.4.6 Limiting

PROC AMP Hrd Clip

Since gain can be applied to the D1 signal it is possible to generate levels outside the normal 10 bit gamut of D1 and so limiting is required. The V6414 Proc Amp normally applies a soft form of limiting that progressively reduces the gain of a signal as it approaches the limits, either overshoot or undershoot. If this is not required then it can be disabled on the **PROC AMP : Hrd Clip** menu.

The limiting that is applied is 'simple' in that it does not ensure that the output is correctly within the colour gamut, but only that each of the three components (Y, Cb, Cr) remains within the legal 10 bit range.

Certain test patterns, most notable the amplitude ramps, contain data that is within the overshoot and undershoot areas. If they are passed through the Proc Amp with its default soft clipping then they will be modified. This means that the EDH value on the output will be different to that on the input. If this is not wanted then the Hard Clipping can be turned ON, but this is not recommended for normal Proc Amp operation.

3.4.7 Fade to Black

PROC AMP Fade>Blk

V6414 modules with the VP option fitted include a fade to black facility. This enables the output to be cleanly attenuated to digital black on receipt of an internal command.

The rate of the fade is fixed at half a second.

Locally the fade can be initiated on the **PROC AMP : Fade>Blk** menu. This contains both an ON and OFF command.

The fade can also be initiated over the DART remote control network. The fade will start as soon as the command is sent.

The output will stay at black until any active control input is released, or the unit is reset. There is no direct indication on the front panel that the output is being forced to black except for the top level banner, if enabled.



V6414AH

3.5 Audio Handling

The V6414 provides some functionality for dealing with embedded audio. These functions are summed up in a group called 'AUDIO'.

The main task is to 'transfer' the embedded audio information between the different domains, i.e. from HD to SD, whilst preserving its original digital content.

Audio is de-embedded before video processing, then re-embedded afterwards. The audio delay is automatically matched to the video processing delay to within 1ms.

3.5.1 Audio Group Selection

AUDIO	Aud Grp1	20bit/24bit/Off
	Aud Grp2	20bit/24bit/Off
	Aud Grp3	20bit/24bit/Off
	Aud Grp4	20bit/24bit/Off

Audio groups can be switched ON and OFF, but not shuffled. Channels within a group remain unchanged in their order. Locally the settings can be made on the **AUDIO : Aud Grp#** menu.

3.5.2 Audio Group Status

STATUS	Aud Grps	1 (2,3,4) indicates Group is present
		- indicates Group is absent

The presence/absence of Audio Groups can be checked in the **STATUS : Aud Grps** menu.

Please note that if the V6414 comes with the Frame Synchroniser option fitted, any ancillary data will be blanked altogether if **VIDEO : Anc Data** is set to *Anc Blnk*.



Vistek V6414 HD Down Converter

3.6 Closed Captions

V6414CP

The V6414 provides some functionality for dealing with closed caption data. These functions are summed up in a group called 'CCAPTION'.

The main task is to 'transcode' or transfer the closed caption information between the different domains, i.e. from HD to SD, whilst preserving its original digital content.

The data is read from the input before video processing, then inserted afterwards.

Support is provided for CEA-608 and CEA-708 type captions using SMPTE-334M to carry the data in HD video formats.

Data can be transcoded or transferred in the following configurations:

Input	Output
SD - CEA-608 : line 21	SD - CEA-608 : line 21
HD - CEA-708 : (608 data) SMPTE 334M	SD - CEA-608 : line 21

3.6.1 SD Captions

Caption data as defined in CEA-608 is transported as an analogue waveform (typically on line 21) in the active picture of an SD frame. Data can be read from and inserted onto the SD video in the CEA-608 line 21 format.

In 525 Line 21 data can be present on line 21 to 25 and/or 284 to 289.

In 625 Line 21 data can be present on line 22 to 26 and/or 335 to 339.

Data is always inserted on line 21 and/or 284 of the 525 frame, and 22 and/or 335 of the 625 frame.

3.6.2 HD Captions

Caption data is carried in SMPTE 334M packets in the HD video standards. Packets will be read from any area in the VANC period of the input.



3.7 Wide Screen Signalling (WSS)

3.7.1 General

The V6414 down converter offers the facility of incorporating wide screen signalling data on the output of the unit. The data carried in each of two transport mechanisms is primarily intended to indicate the Aspect Ratio of the output signal.

Please note that wide screen signalling data insertion is only available when down converting between high definition input signals and standard definition output signals; it is NOT available when bypassing between standard definition inputs and outputs.

3.7.2 ETSI Line 23 WSS Insertion

WSS ETSI Ins

ETSI Line 23 coding is used by many broadcasters as a method of transmitting wide screen signalling (and other) information to home consumers. The data received at the consumer's TV is used to decide how best to display the received image. The data is added to the first half of line 23. This is within the vertical blanking interval, and should not be visible on a correctly aligned television.

A full technical description of ETSI line 23 coding is available in the ETSI document number ETS 300 294.

The ETSI insertion control (**ETSI Ins**) allows the user to add line 23 WSS data onto the output signal, or not.

ETSI Ins **ETSI Off** ETSI line 23 data not added. Normalised position.

ETSI Ins **ETSI On** ETSI line 23 data added.

See section 6.4 (ETSI Line 23 and Video Index Insertion Codes) in the appendix for details of the group 1 Aspect Ratio information bits added to the output signal for each display aspect ratio settings. All information bits carried in groups 2, 3 and 4 of the line 23 WSS signal are defaulted to zero (no support for these).

Please note that ETSI line 23 data insertion is NOT available when 'bypassing' between standard definition inputs and outputs.



Vistek V6414 HD Down Converter

3.7.3 Video Index (VI) Insertion

WSS VI Ins

Video Index is a technique used to encode program and picture related source information into a component digital video signal. The data is encoded in bit 2 of the chrominance signal (assuming a 10 bit signal, where bit 0 is the LSB and bit 9 is the MSB), on lines 11 and 324 for a 625 line signal, or lines 14 and 277 for a 525 line signal. The data is organised into three groups called classes:-

Class 1 Information required to display or perform processing upon the picture.

Class 2 How the video was originated or previously processed.

Class 3 Other information relating to the video but not needed for display.

The classes are further divided into sub-classes (eg Class 1.1, 1.2 and 1.3). For further details of all the information that can be transported by the video index system we advise studying the SMPTE RP186 document.

Class 1.1 is mandatory and holds information required to display the signal:

Class 1.1 Data Octet 1:- Scanning System	B7	B6	B5	B4	B3	B2	B1	B0
No information	0	0	0	0	0	0	0	0
525/59.94 / 4x3	0	0	0	0	0	0	0	1
625/50 / 4x3	0	0	0	0	0	0	1	0
Reserved	0	0	0	0	0	0	1	1
Reserved	0	0	0	0	0	1	0	0
525/59.94 / 16x9	0	0	0	0	0	1	0	1
625/50 / 16x9	0	0	0	0	0	1	1	0
Reserved, from through to	0 1	0 1	0 1	0 1	0 1	1 1	1 1	1 1

In the SMPTE RP186 specification the upper 5 bits of class 1.1 data octet 1 are reserved for future use. The V6414 uses 3 of these bits (B5, B4 and B3) to encode the Active Format Descriptor (AFD):-

AFD2 = B5

AFD1 = B4

AFD0 = B3

Active Format Descriptor (AFD)	Description
0	Active region is same as coded frame.
1	4:3
2	16:9
3	14:9
4	Reserved for future use.
5	4:3 with shoot-and-protect 14:9 centre
6	16:9 with shoot-and-protect 14:9 centre
7	16:9 with shoot-and-protect 4:3 centre



The V6414 inserts 0 (no information) in the remaining 2 data octets of class 1.1

The V6414 defaults all class 1.2, 1.3, 2.1, 2.2 and 2.3 data to zero, the no information state.

The Video Index insertion control (**VI Ins**) allows the user to add Video Index data onto the output signal, or not.

VI Ins **VI Off** Video Index data not added. Normalised position.

VI Ins **VI On** Video Index data added.

See section 6.4 (ETSI Line 23 and Video Index Insertion Codes) in the appendix for details of the class 1.1 octet 1 Video Index data added to the output signal for each display aspect ratio settings.

Please note that Video Index data insertion is NOT available when 'bypassing' between standard definition inputs and outputs.

3.8 Time Code and Source Identification

3.8.1 General

The V6414 offers the facilities of reading Digital Vertical Interval Time Code (DVITC), Ancillary Time Code (ATC) and source identification (SID) information from the input signal to the unit (in High Definition format), and with some minimal internal processing pass the data to the output of the unit (in Standard Definition format). Appropriate delays are applied to the time code and source ID data to match the video signal processing delay through the unit (4 fields).

If the input to the unit is of Standard Definition (SD) format then the timecode and source ID data is bypassed directly to the output (again via appropriate delays) without any other internal processing being applied.

It must be noted that the V6414 unit does NOT contain a time code generator module. As a consequence, if there is no time code data on the input to the unit then there will be no time code data on the output of the unit.

3.8.2 DVITC Time Code Processing Controls

There are three controls available to the user for controlling/modifying the DVITC time code output from the unit. These are:- DVITC source selection, DVITC insertion control and DVITC output line selection.

The DVITC source selection control (**AUX DATA : DVITCSrc**) allows the user to select either the DVITC or Ancillary (ATC) time code data taken from the input signal to the unit to be re-inserted as DVITC time code at the output of the unit.



Vistek V6414 HD Down Converter

The DVITC insertion control (**AUX DATA : DVITCIns**) allows the user to enable or disable the re-insertion of DVITC time code on the output of the unit.

The DVITC output line selection control (**AUX DATA : DVITC Ln**) allows the user to select which line(s) the DVITC time code data is inserted onto at the output of the unit. There are two separate settings, one for 625 line standard definition outputs and one for 525 line standard definition outputs.

It must be noted that the above three controls have no effect when the input to the unit is of Standard Definition format. Under these conditions the DVITC data present at the input of the unit is 'bypassed' directly through to the output of the unit.

3.8.3 Ancillary Time Code (ATC) Processing Controls

There are five controls available to the user for controlling/modifying the Ancillary (ATC) time code output from the unit. These are:- ATC reader format selection, ATC source selection, ATC insertion control, ATC output line selection and the ATC output location selection.

The ATC reader format selection (**AUX DATA : ATC Read**) allows the user to define which form of Ancillary time code should be accepted/read by the ATC reader module. Under most operating conditions this control should be set to the default position, **Any**. However, it is possible that a user may wish to only allow the reader to accept a specific form of ATC time code data. In these circumstances the user has the option of setting this control to one of the other three settings: **LTC**, **VITC1** or **VITC2**.

The ATC source selection control (**AUX DATA : ATC Src**) allows the user to select either the DVITC or Ancillary (ATC) time code data taken from the input signal to the unit to be re-inserted as ATC time code at the output of the unit.

The ATC insertion control (**AUX DATA : ATC Ins**) allows the user to enable or disable the re-insertion of ATC time code on the output of the unit.

The ATC output line selection control (**AUX DATA : ATC Line**) allows the user to select which line(s) the ATC time code data is inserted onto at the output of the unit. There are two separate settings, one for 625 line standard definition outputs and one for 525 line standard definition outputs.

The ATC output location selection control (**AUX DATA : ATC Loc**) allows the user to define whether the Ancillary time code is inserted into either the **VANC** or **HANC** periods of the output signal. Under most operating conditions this control should be set to the default position, **VANC**.

It must be noted that the above five controls have no effect when the input to the unit is of Standard Definition format. Under these conditions the ATC data present at the input of the unit is 'bypassed' directly through to the output of the unit.



3.8.4 Source Identification (SID) Processing Controls

There are two controls available to the user for controlling/modifying the Source Identification output from the unit. These are the Source Identification insertion control and the Source Identification output line selection.

The Source Identification insertion control (**AUX DATA : SID Ins**) allows the user to enable or disable the re-insertion of Source Identification on the output of the unit.

The Source Identification output line selection control (**AUX DATA : SID Line**) allows the user to select which line(s) the Source Identification data is inserted onto at the output of the unit. There are two separate settings, one for 625 line standard definition outputs and one for 525 line standard definition outputs.

It must be noted that the above two controls have no effect when the input to the unit is of Standard Definition format. Under these conditions the Source Identification data present at the input of the unit is 'bypassed' directly through to the output of the unit.



4 Calibration

This section describes how to calibrate the unit as it is done in the factory. The units do not contain any potentiometers, but like most equipment with analogue parts still needs to be calibrated. Normally this calibration is done in the factory and should not need to be repeated in the field but this section describes the procedure and is included for completeness.

High quality, calibrated test equipment should be used for this calibration. Note that it is not possible to return to the pre-calibration settings other than by making a note of the values and re-entering them.

4.1 Set-Up

There is a separate Main Level Menu for Calibration and this should be used throughout. The first sub-level menu is Cal Mode, which can be used to turn calibration ON:

```
CALIB      Cal Mode  Cal Off
                Cal On
```

The calibration mode must be turned ON before any parameter can be adjusted. The calibration mode will be turned OFF in one of four ways:

- Manually on the **CALIB : Cal Mode** menu
- By going up to the Top Level Menu
- By re-powering the unit.
- By letting the display timeout and go to sleep mode.

When the calibration mode is ON then the unit will automatically set up the required conditions in the unit as you enter each sub-menu. For example, if you go into the CntrFreq sub-menu, the unit will automatically go into free run. For obvious reasons this should not be done on a unit that is being used On Air.



4.2 Free-Run Frequency

There is a voltage controlled crystal oscillator, which is usually locked to the external video reference or to the input video. However if there is no input or reference then it will free-run and this free running frequency should be set. The oscillator is not accurate enough to be used as a frequency reference, but nevertheless, should be set close to the ideal so that any succeeding SDI equipment will be able to lock to its output, and so that when in free run it will only drift slowly away from its starting reference.

To calibrate the frequency set the unit into Free Run by turning Cal Mode ON and selecting the CntrFreq sub-menu.

```
CALIB      Cal Mode  Cal On
```

Now compare the output picture movement on a monitor with an accurate external reference and adjust the frequency accordingly.

```
CALIB      CntrFreq          Range is -127 to +128
```

The setting is stored on the unit in non-volatile memory, and should not need regular adjustment.



5 Controls

These tables show a complete list of all the parameters that can be controlled locally for the various configurations. Unless otherwise shown they can also be controlled over the DART remote control system. Not all menus are available at any one time, since they depend on module configurations and sometimes on the operating conditions.

The tables also show the full range of the controls and their ranges and normalised value, if appropriate. The normalised value or setting is shown by the 'n'.

5.1 Video Processing – VIDEO

Main Menu	Sub Menu	Value		Comment	V6414
VIDEO	Source	I/P 1	n		Ü
		I/P 2			Ü
		Black			SY
	A/R	4:3 ANA	n	4:3 Anamorphic	Ü
		16:9 LB		16:9 Letter Box	
		14:9 LB		14:9 Letter Box	
		4:3 CC		4:3 Centre Cutout	
	Ref Src	Auto	n	selects Ref I/P if present	SY
		Vid I/P		selects Video Input	
		Ref I/P		selects Reference Input	
	Anc Data	Anc Blnk	n	Blank Anc Data (set to 'Black')	SY
		Anc Pass		Pass Anc Data through	
	6302Data	6302 Off	n		
		6302 On			
	VFL Mode	Black	n	Instant Black on I/P Fail	SY
		1 sec		from Black after 1 sec...	
		↓		in increments of 1 sec	
		13 sec		...to Black after 13 sec	
		To I/P 2		Switch to input 2 on I/P Fail	
	RFL Mode	Freeze	n	Instant Freeze on I/P Fail	SY
		Min Dly	n		
	XStdMode	Adj Dly			SY
		XStd Ref	n		
Freeze	XStd I/P			SY	
	Run	n			
	Field 1				
	Field 2				
	Frame				

Vistek V6414 HD Down Converter



Video Processing – VIDEO (cont.)

Main Menu	Sub Menu	Value		Comment	V6414
VIDEO	F Delay	0	n	The maximum delay depends on the baseboard configuration (24MB or 96MB) and the detected Input Standard. If the Input Standard is progressive, the number displayed means xx-'Frames'. If the Input Standard is interlaced, the number displayed means xx-'Fields'.	FD
		↓			
		xx			
	V Delay	+0	n	With Vid I/P as reference	SY
		↓		Range dependent on mode!	
		+749			
	H Delay	+0.00μs	n	With Vid I/P as reference	SY
		↓		Range dependent on mode!	
		+22.23μs			
	V Timing	-256		With Ext. Reference	SY
		↓			
		+0	n		
		↓			
	H Timing	+0.00μs	n	With Ext. Reference	SY
		↓		Range dependent on mode!	
+22.23μs					
Norm		*****			ü

Legend:

- ü Feature available on Standard version
- VP VP (Video Proc Amp) option required
- SY SY (Frame Synchroniser) option required
- FD FD (Field/Frame Delay) option required
- AH AH (Audio Handling) option required



Vistek V6414 HD Down Converter

5.2 Operating Conditions – STATUS

Main Menu	Sub Menu	Value	Comment	V6414
STATUS	Variant	V6414	HD Down Converter	ü
	Options	None	No extra option enabled	ü
		F Sync	Frame Synchroniser	
		FD	Frame Delay	
		AH	Audio Handling	
		CP	Closed Captioning	
		V6302	Attached	
		None		
	Sub-Mod	Missing		ü
		Fitted		
	Source	I/P 1		ü
		I/P 2		
		Black		
	I/P Std	720p59	Auto detected Input Standard	ü
		↓		
		525i59		
		625i50		
		Unknown		
	I/P 1	I/P 1 √	present	ü
		I/P 1 x	absent	
	I/P 2	I/P 2 √	present	ü
		I/P 2 x	absent	
	Ref I/P	Ref √	present	ü
		Ref x	absent	
	Ref Std	720p59	Auto detected Ref. Standard	ü
		↓		
		525i59		
		625i50		
		Unknown		
	O/P Std	720p59	Output Standard	ü
		↓		
		525i59		
		625i50		
		Unknown		
	Aud Grps	None		AH
		1 2 3 4	Number indicates Grp present	
1 - - -		- indicates Grp absent		
GPI STAT	GPI ↓	GPI connection:- Open	ü	
	GPI ↑	GPI connection:- Closed		
CEA608	CEA608 √	present	ü	
	CEA608 x	absent		

Vistek V6414 HD Down Converter



Operating Conditions – STATUS (cont.)

Main Menu	Sub Menu	Value	Comment	V6414
STATUS	CEA708	CEA708 ✓	present	ü
		CEA708 x	absent	
	Mem Size	24MBytes	Amount of SDRAM fitted on Baseboard	ü
		96Mbytes		
	VModule	HD PROC	fitted on V6414	ü
		None		
	IOModule	ID 0	Standard I/O Daughter Board	ü
		ID 1	reserved	
		ID 2	reserved	
		None		
	SC Temp	49.6 °C		ü
	Soft Ver	08.00.00		ü
	FPGA Ver	05.12		ü
	CPLD Ver	00.01		ü
	PCB Rev	03.02		ü
	Strx Ver	1.1.0		ü
SMod Ver	00		ü	
Boot Ver	01.00.01		ü	

Legend:

- ü Feature available on Standard version
- VP VP (Video Proc Amp) option required
- SY SY (Frame Synchroniser) option required
- FD FD (Field/Frame Delay) option required
- AH AH (Audio Handling) option required



Vistek V6414 HD Down Converter

5.3 Engineering – ENG'ING

Main Menu	Sub Menu	Value		Comment	V6414
ENG'ING	Ref Src	Auto	n	defaults to Ref I/P if present	SY
		Vid I/P		selects Video Input	
		Ref I/P		selects Reference Input	
	Test Ptn	TPG Off	n	Test Pattern 'Off'	SY
		Bars 100		100% Colour Bars	
		Bars 75		75% Colour Bars	
		SDI Mtrx		SDI Check Field (Pathologicals)	
		X-Hair		Cross Hair (Timing)	
		Ramp		Linear Ramp	
		Flat Wht		Flat White	
		Custom		t.b.d.	
	O/P EDH	EDH On	n	only when O/P standard is SD	Ü
		EDH Off			
	H Res	H High	n	Horizontal resolution control	Ü
		H Medium			
		H Low			
	V Res	V High	n	Vertical resolution control	Ü
		V Medium			
		V Low			
	Byp Dly	Dly Comp	n		Ü
		Min Dly			
	Mot Adpt	Adpt On	n	Motion adaptive de-interlacing	Ü
		Adpt Off		Single field de-interlacing	
	Delay (see Note 1)	0 Second	n	No extra delay	FD
		1 Second		Adds 1 second fixed delay on top of arbitrary Field Delay in 525i59 and 625i50 modes	
	Free-run	Free Off	n		Ü
		Free On			
Sleep	0 min		LED Display never falls asleep	Ü	
	↓				
	5 min	n	Sleep after 5 minutes (default)		
	↓				
	30 min		Sleep after 30 minutes		
LEDLevel	■ ■ ■ ■	n	LED Display Intensity	Ü	
Norm	*****			Ü	

Note 1: Requires a baseboard with 96MByte Framestore



5.4 Calibration – CALIB

Main Menu	Sub Menu	Value		Comment	V6414
CALIB	Cal Mode	Cal Off	n		ü
		Cal On		Must be set 'On' to enable calibration (CntrFreq setting)	
	CntrFreq	Frq=-128		Free-run Frequency	ü
		Frq= +0	n		
		Frq=+127			
	Norm	*****			ü

Legend:

- ü Feature available on Standard version
- VP VP (Video Proc Amp) option required
- SY SY (Frame Synchroniser) option required
- FD FD (Field/Frame Delay) option required
- AH AH (Audio Handling) option required



Vistek V6414 HD Down Converter

5.5 Configuration – CONFIG

Main Menu	Sub Menu	Value		Comment	V6414
CONFIG	GPI	GPI OFF	n	GPI has no function	ü
		GPI SDI1		Activate to select I/P 1	
		GPI SDI2		Activate to select I/P 2	
		GPI BARS		Activate to O/P Bars (SY)	
	Banner	On	n	This enables the Warning Msg. Banner.	ü
		Off			
	DefIpStd	720p59	n	Default Standard This is the default I/P standard that will be selected when no valid Video Input signal is present.	ü
		720p50			
		1080i59			
		1080i50			
		525i59			
	625i50				
	Password	0	n		ü
	Variant	V6414		Factory enabled option	ü
	F Sync	None		Factory enabled option	ü
		Fitted			
	Vid Proc	None		Factory enabled option	ü
		Fitted			
	Fld Dely	None		Factory enabled option	SY
		Fitted			
	Cl Captn	None		Factory enabled option	ü
		Fitted			
	Aud Hndl	None		Factory enabled option	ü
		Fitted			
	SD/HD Op	Auto	n	Auto-sensing of I/P standard	ü
		HD		I/P forced to HD operation	
		SD		I/P forced to SD operation	
	PCB Rev	0		Password protected	ü
		↓			
		15			
	H/W Rev	0		Password protected	ü
		↓			
		15			
	TestMode	Off	n		ü
		On			
	Mem Test	On	n	Execute SDRAM Test @Pwr-On	ü
		Off			
	Factory	Mode Off	n	Password protected facility	ü
		Mode On		Not for customer use	
	Norm	*****			ü



5.6 Video Proc Amp – PROC AMP

Note: This menu is only available on modules with the VP (Video Proc Amp) option enabled.

Main Menu	Sub Menu	Value		Comment	V6414	
PROC AMP	V Gain	-6.02dB		Video Gain Control	VP	
		↓				
		-0.00dB	n			
		↓				
			+6.01dB			
	C Gain	-6.02dB		Chroma Gain Control	VP	
		↓				
		-0.00dB	n			
		↓				
			+6.01dB			
	Blk Lvl	-128		Black Level Control	VP	
		↓				
		+0	n			
		↓				
			+127			
	Hue	-45.00°		Hue Control	VP	
		↓				
		+0.00°	n			
		↓				
			+44.65°			
Bypass	Byp Off	n	Proc Amp Bypass Off	VP		
	Byp On		Proc Amp Bypass On			
Dyn Rdn	DR On	n	Dynamic Rounding On	VP		
	DR Off		Dynamic Rounding Off			
Hrd Clip	HClp Off	n	Hard Clipping Off	VP		
	HClp On		Hard Clipping On			
Fade>Blk	F>B Off	n	Fade to Black Off	VP		
	F>B On		Fade to Black On			
Norm	*****			VP		

Legend:

- ü Feature available on Standard version
- VP VP (Video Proc Amp) option required
- SY SY (Frame Synchroniser) option required
- FD FD (Field/Frame Delay) option required
- AH AH (Audio Handling) option required



Vistek V6414 HD Down Converter

5.7 Audio Handling – AUDIO

Note: This menu is only available on modules with the AH (Audio Handling) option enabled.

Main Menu	Sub Menu	Value		Comment	V6414
AUDIO	Aud Grp1	Grp1 20b	n		AH
		Grp1 24b			
		Grp1 Off			
	Aud Grp2	Grp2 20b	n		AH
		Grp2 24b			
		Grp2 Off			
	Aud Grp3	Grp3 20b	n		AH
		Grp3 24b			
		Grp3 Off			
	Aud Grp4	Grp4 20b	n		AH
		Grp4 24b			
		Grp4 Off			
		Norm	*****		

5.8 Closed Captioning – CCAPTION

Note: This menu is only available on modules with the CP (CLOSED CAPTIONING) option enabled.

Main Menu	Sub Menu	Value		Comment	V6414
CCAPTION	O/P CCap	CCap On	n	Output captions if present	CP
		CCap Off		Disable caption output	
		Norm	*****		

Legend:

- ü Feature available on Standard version
- VP VP (Video Proc Amp) option required
- SY SY (Frame Synchroniser) option required
- FD FD (Field/Frame Delay) option required
- AH AH (Audio Handling) option required



5.9 Wide Screen Signalling – WSS

Main Menu	Sub Menu	Value		Comment	V6414
WSS	ETSI Ins	ETSI Off	n	ETSI line 23 data not inserted	ü
		ETSI On		ETSI line 23 data inserted	
	VI Ins	VI Off	n	Video Index data not inserted	ü
		VI On		Video Index data inserted	
	Norm	*****			ü

5.10 Auxillary Data – AUX DATA

Main Menu	Sub Menu	Value		Comment	V6414
AUX DATA	DVITCSrc	DV ATC	n	DVITC source:- taken from ATC on input signal	ü
		DV DVITC		DVITC source:- taken from DVITC on input signal	
	DVITCIns	DVITCoff	n	Do not insert DVITC on the output signal	ü
		DVITC On		Insert DVITC on the output signal	
	DVITC Ln	Ln22/335		< 625 O/P 525 O/P > Ln19/282	ü
		↓		DVITC output line select	
		Ln15/328	n	< 625 O/P 525 O/P > Ln12/275	
		↓			
	ATC Read	Ln 7/320		< 625 O/P 525 O/P > Ln 4/267	ü
		AR Any	n	ATC reader:- read any form of ATC on I/P signal	
		AR LTC		ATC reader:- only detect LTC coded ATC on I/P	
		AR VITC1		ATC reader:- only detect VITC1 coded ATC on I/P	
	ATC Src	AR VITC2		ATC reader:- only detect VITC2 coded ATC on I/P	ü
		AS ATC	n	ATC source:- taken from ATC on the input signal	
	ATC Ins	AS DVITC		ATC source:- taken from DVITC on the input signal	ü
		ATC Off	n	Do not insert ATC on the output signal	
	ATC Line	ATC On		Insert ATC on the output signal	ü
		Ln22/335		< 625 O/P 525 O/P > Ln19/282	
		↓		ATC output line select	
		Ln15/328	n	< 625 O/P 525 O/P > Ln12/275	
	ATC Loc	↓			ü
		Ln 7/320		< 625 O/P 525 O/P > Ln 4/267	
	ATC Loc	ATC VANC	n	Location of ATC on output signal:- in VANC	ü
		ATC HANC		Location of ATC on output signal:- in HANC	
	SID Ins	SID Off	n	Do not insert SID on the output signal	ü
		SID On		Insert SID on the output signal	
	SID Line	Ln22/335		< 625 O/P 525 O/P > Ln19/282	ü
		↓		SID output line select	
		Ln15/328	n	< 625 O/P 525 O/P > Ln12/275	
		↓			
	Norm	Ln 7/320		< 625 O/P 525 O/P > Ln 4/267	ü



6 Appendix

6.1 Trouble Shooting Guide (Frequently Asked Questions)

This section is to be a help in solving some common difficulties. If there is no control from the front panel first check that the Rem/Local switch is set to *Local*.

Q:	My V6414 powers-up with a static test pattern or black output, although a valid SDI video signal is connected to one of its inputs.
A1:	Check whether the Front Panel HD/SD LED is lit. This indicates that a signal is being received.
A2:	Check whether the Input selection is set correctly. <code>VIDEO : Source : I/P 1 (or I/P 2)</code>
A3:	Check that the Test Pattern Generator is turned off. <code>ENG'ING : Test Ptn : TPG Off</code>
A4:	Make sure that the mode of operation (SD/HD) matches with your Input Standard. Set to 'Auto' sensing if in doubt. <code>CONFIG : SD/HD Op : Auto</code>

Q:	My V6414 does not synchronise to the external reference.
A1:	Check whether the Front Panel Ref. LED is lit. This indicates the presence of an ext. reference.
A2:	Check whether the ext. reference input is selected. <code>VIDEO : Ref Src : Auto (or Ref IP)</code>

Q:	It seems that embedded Audio data does not get passed through the Frame Synchroniser (in fact, no Ancillary data whatsoever).
A1:	Check whether the Anc Data enable control is set properly. <code>VIDEO : Anc Data : Anc Pass</code>

Q:	I want to add a number of frames extra delay to the output, but I cannot find the associated menu item.
A1:	The V6414SY needs to have the Field/Frame-Delay (FD) option enabled. This is a factory installed option and requires a password in order to enable it. If the option is enabled, you will find the corresponding control menu under <code>VIDEO : F Delay</code> .

Q:	The output generated by my V6414 looks corrupted.
A1:	Make sure that the selected Output Standard has the same frame-rate as the Input signal.



Q:	I want to use my V6414SY as a stand-alone Test Pattern Generator, but I cannot see anything on the Monitor.
A1:	Make sure that the selected 'Default Standard' is compatible with your Monitor specification (CONFIG : Def Std). Note that some Broadcast Monitors cannot cope with progressively scanned modes with frame-rates less than 50Hz.
A2:	Check whether the TPG is turned on and that you have not deliberately selected a 'Black' test pattern (ENG' ING : TestPtn : Bars 100, Bars 75, etc.)

Q:	The Proc Amp does not work.
A1:	Check whether it is set to Bypass. PROC AMP : Bypass : Byp Off

Q:	The display never goes to sleep.
A1:	Check whether the Sleep delay has been set to 0 Mins, which means stay awake.

6.2 Initialization, Power On-Selftest & Error Messages

6.2.1 Board Initialization Sequence

Every time a board goes through a power-on cycle, either by re-seating the board in the rack or by triggering the manual reset, a sequence of initialisation and self-test events is being carried out by the on-board microcontroller.

If anything goes wrong, an error message is shown on the front panel display and program execution halts. The following table shows the error messages and their meaning:

Flash upgrading	ERROR 01	Flash erasing failed
	ERROR 02	Flash programming failed
	ERROR 03	Main program checksum error after programming
	ERROR 04	Bootloader checksum error after programming
	ERROR 05	No program loaded and no valid upgrade in Flash Stick
	ERROR 06	Bootloader upgrade required but no valid bootloader upgrade in Flash Stick
FPGA Load	ERROR 07	STATUS stayed low after CONFIG pulsed low
	ERROR 08	DONE stayed high after CONFIG pulsed low
	ERROR 09	STATUS went low during configuration
	ERROR 10	DONE stayed low after configuration
Local EEPROM	ERROR 11	Error writing to local EEPROM
	ERROR 12	Error reading from EEPROM
	ERROR 13	Initialising EEPROM to default data
	ERROR 14	Initialising parameters to default data
Debug Port	ERROR 15	Receive buffer overflow
	ERROR 16	Receive overrun
	ERROR 17	Receive framing error
	ERROR 18	Receive parity error



Vistek V6414 HD Down Converter

6.2.2 SDRAM Test

An automatic SDRAM test is being carried out on the V6414 baseboard with firmware V02.00 (or higher) as part of the power-on self-test sequence. This is subject to the corresponding setting in the CONFIG Menu (**Mem Test ON/OFF**) - **Mem Test** is set to 'ON' by default. In case of an error, the front panel display will show one of the following **SDRAM test exit codes**:

SDRAM Test	MEM ERR0	SDRAM Databus Bit(s) stuck @ 0
	MEM ERR1	SDRAM Databus Bit(s) stuck @ 1
	MEM ERR2	Neighbouring SDRAM Databus Bit(s) are shorted
	MEM ERR3	Neighbouring SDRAM Databus Bit(s) are shorted
	MEM ERR4	SDRAM Address lines (A10-A0) are shorted or open
	MEM ERR5	SDRAM Bank Select lines (BA0, BA1) are shorted or open
	MEM ERR6	Error whilst filling the SDRAM with 'black' pattern
	MEM ERR7	Timeout error (internal FPGA problem)

6.3 Menu Structure

The following page summarizes the menu structure on the V6414 module.

Please note that the presence of some sub-menus depend on the factory configuration of your module. In other words, if an option is not fitted, the entire sub-menu belonging to it will not appear in the menu structure.

V6414 Menu Structure

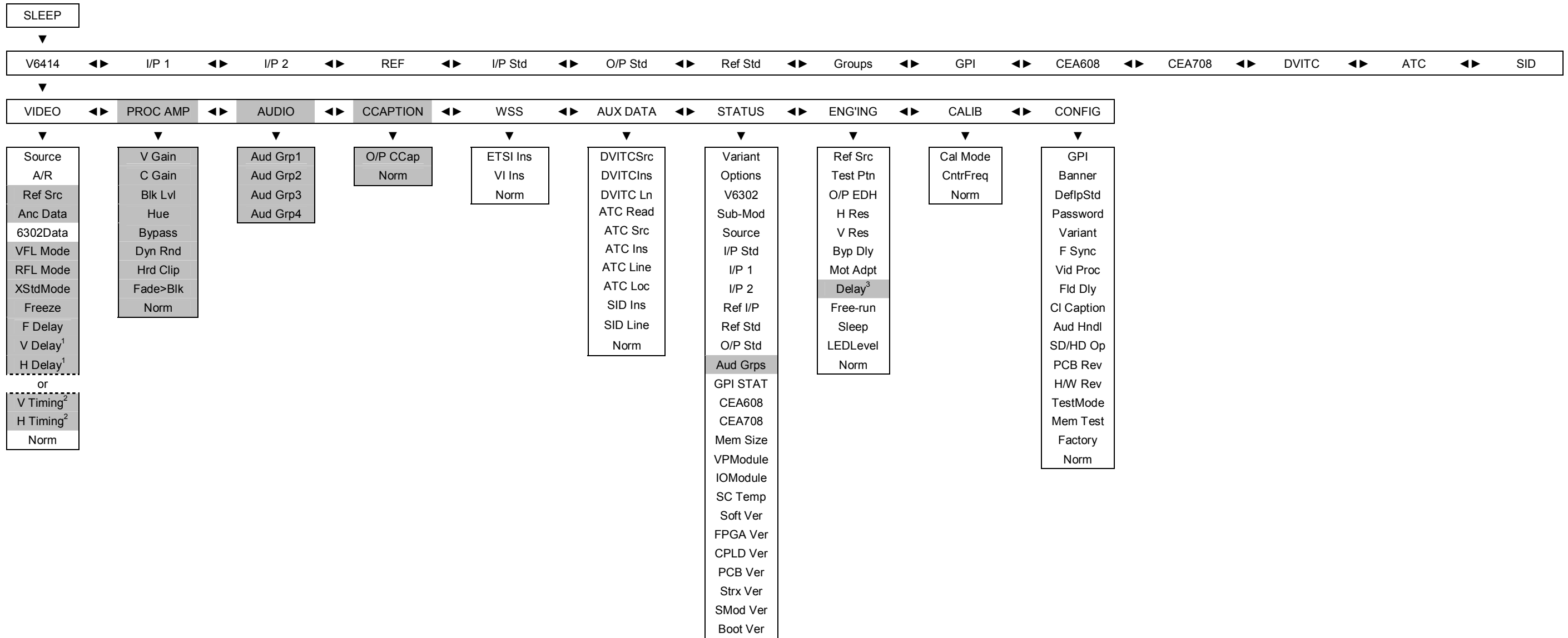

Legend: n Password enabled Option(s)

Notes: 1. Reference is Vid I/P 2. Reference is Ref I/P 3. Requires 'FD' option, only available with 525i59 and 625i50 Input Std.



6.4 ETSI Line 23 and Video Index Insertion Codes

Input Format	Output Format	Mode	Aspect Ratios	ETSI WSS 14 Information Bits		ETSI WSS Description	Video Index Data Byte		Video Index Description
				b13	b0		b7	b0	
1080i50	625i50	Down	Anamorphic	0000000000	0111	Full format 16x9 (Ana)	00 000 110	AFD=0 625/50 16x9	
			16:9 Letterbox	0000000000	1011	Box 16x9 centre	00 010 010	AFD=2 625/50 4x3	
			14:9 Letterbox	0000000000	0001	Box 14x9 centre	00 011 010	AFD=3 625/50 4x3	
			4:3 Centre Cutout	0000000000	1000	Full format 4x3	00 000 010	AFD=0 625/50 4x3	
720p50	625i50	Down	Anamorphic	0000000000	0111	Full format 16x9 (Ana)	00 000 110	AFD=0 625/50 16x9	
			16:9 Letterbox	0000000000	1011	Box 16x9 centre	00 010 010	AFD=2 625/50 4x3	
			14:9 Letterbox	0000000000	0001	Box 14x9 centre	00 011 010	AFD=3 625/50 4x3	
			4:3 Centre Cutout	0000000000	1000	Full format 4x3	00 000 010	AFD=0 625/50 4x3	
625i50	625i50	Bypass	No picture scaling	0000000000	xxxx	Not inserted; force off	00 xxx xxx	Not inserted; force off	
1080i59	525i59	Down	Anamorphic	0000000000	xxxx	Not inserted; force off	00 000 101	AFD=0 525/59 16x9	
			16:9 Letterbox	0000000000	xxxx	Not inserted; force off	00 010 001	AFD=2 525/59 4x3	
			14:9 Letterbox	0000000000	xxxx	Not inserted; force off	00 011 001	AFD=3 525/59 4x3	
			4:3 Centre Cutout	0000000000	xxxx	Not inserted; force off	00 000 001	AFD=0 525/59 4x3	
720p59	525i59	Down	Anamorphic	0000000000	xxxx	Not inserted; force off	00 000 101	AFD=0 525/59 16x9	
			16:9 Letterbox	0000000000	xxxx	Not inserted; force off	00 010 001	AFD=2 525/59 4x3	
			14:9 Letterbox	0000000000	xxxx	Not inserted; force off	00 011 001	AFD=3 525/59 4x3	
			4:3 Centre Cutout	0000000000	xxxx	Not inserted; force off	00 000 001	AFD=0 525/59 4x3	
525i59	525i59	Bypass	No picture scaling	0000000000	xxxx	Not inserted; force off	00 xxx xxx	Not inserted; force off	