



V6821 + V6822

***HD* VALID Reader**

INSTALLATION and OPERATION

© Pro-Bel Ltd

Filename: V6821_22om_11.doc
Issue: 1.1
Date: October 07

**Pro-Bel Ltd
Hartman House
Danehill
Lower Early
Reading
Berks, RG6 4PB
ENGLAND**

Tel. +44 118 986 6123
Fax. +44 118 975 5787
Web: www.pro-bel.com



CONTENTS

| | |
|----------------------------------------------------------|-----------|
| 1. DESCRIPTION | 5 |
| 1.1 General | 5 |
| 1.2 Video Standards | 6 |
| 1.2.1 Supported Video Standards | 6 |
| 2. INSTALLATION | 7 |
| 2.1 Rear Panels | 7 |
| 2.2 Connections | 8 |
| 2.2.1 Video Connections | 8 |
| 2.2.1.1 SDI Inputs | 8 |
| 2.2.1.2 SDI Reclocked & Buffered Output | 8 |
| 2.2.1.3 SDI Main Outputs | 8 |
| 2.2.1.4 Video Reference | 8 |
| 2.2.2 Audio Connections – V16HR3H | 9 |
| 2.2.3 Audio Connections – V16HR3K | 9 |
| 2.2.4 HDD44 Connector - Analogue Audio I/O | 10 |
| 2.2.5 HDD26 Connector - Digital Audio I/O and signalling | 11 |
| 2.2.6 Breakout Cables and Panels | 11 |
| 2.3 Module and Environmental Specifications | 12 |
| 2.4 Signal Specifications | 13 |
| 2.5 Insertion Delay | 13 |
| 2.6 Hardware | 14 |
| 2.6.1 V6821 PCB | 14 |
| 2.6.2 V6822 PCB | 14 |
| 2.6.3 V6821 Links and Switches | 15 |
| 2.6.4 V6822 Links and Switches | 15 |
| 2.6.5 V6821 Fuse | 16 |
| 2.6.6 V6822 Fuses | 16 |
| 2.6.7 Flash Memory Card | 16 |
| 2.7 Front Panels | 17 |
| 2.7.1 LEDs & Switches | 17 |
| 2.8 Module Placement | 18 |
| 3. SYSTEM CONTROL | 19 |
| 3.1 Local Control | 19 |
| 3.1.1 Start up | 19 |
| 3.1.2 Menu Control | 19 |
| 3.1.3 Menu Examples | 20 |
| 3.1.4 Sleep | 20 |
| 3.2 Remote Control | 21 |
| 4. VALID SYSTEM | 22 |
| 4.1 Overview | 22 |
| 4.2 Time Stamps | 23 |
| 4.3 Video | 23 |
| 4.3.1 Test Patterns | 23 |
| 4.3.2 Caption ID Text | 23 |
| 4.3.3 Timing Circle | 23 |
| 4.3.4 Black Cross Flash | 24 |
| 4.3.5 VALID Synchronisation | 24 |
| 4.3.6 Video Synchronisation | 24 |
| 4.4 Audio | 25 |
| 4.4.1 Audio Channel Naming | 25 |
| 4.4.2 Audio Groups | 25 |
| 4.4.3 Audio Tones | 25 |
| 4.4.4 Audio Channel Detection | 25 |
| 4.4.5 Identifying V1681 and V6811 Tones | 27 |
| 4.4.6 Audio Idents (Internal) | 28 |
| 4.4.7 Audio Idents (External) | 29 |
| 4.4.8 Audio Idents – Segments | 30 |
| 4.4.9 Audio Idents – .wav Files | 31 |
| 4.5 Meter Displays | 31 |

CONTENTS (Cont'd)

| | | |
|------------|-----------------------------------------------|-----------|
| 5. | BLOCK DIAGRAMS | 34 |
| 5.1 | V6821 Video Module..... | 34 |
| 5.2 | V6822 Audio Module..... | 35 |
| 6. | SYSTEM OPERATION | 36 |
| 6.1 | VALID Measurements..... | 36 |
| 6.2 | Video Controls..... | 36 |
| 6.2.1 | Input Selection..... | 36 |
| 6.3 | Audio Controls..... | 36 |
| 6.3.1 | Audio Input Selection..... | 36 |
| 6.3.2 | Audio Channel Selection..... | 36 |
| 6.3.3 | MAL (Maximum Analog Level) Set Up..... | 37 |
| 6.4 | Meter Controls..... | 37 |
| 6.4.1 | Meter Types..... | 37 |
| 6.4.2 | Meter Enable..... | 37 |
| 6.4.3 | Level Meter Options..... | 37 |
| 6.5 | Status Menu..... | 37 |
| 6.5.1 | V6821 States..... | 38 |
| 6.5.2 | Audio Status..... | 38 |
| 6.5.3 | Version Numbers..... | 38 |
| 6.6 | Engineering Controls..... | 38 |
| 6.6.1 | EDH (SD operation only)..... | 38 |
| 6.6.2 | Free-Run..... | 38 |
| 6.6.3 | Channel Hold Timing..... | 39 |
| 6.6.4 | Display Sleep..... | 39 |
| 6.6.5 | Display Brightness..... | 39 |
| 6.7 | Config Controls..... | 40 |
| 6.7.1 | GPI control..... | 40 |
| 7. | CALIBRATION | 41 |
| 7.1 | Set-Up..... | 41 |
| 7.2 | Free-Run Frequency..... | 41 |
| 7.3 | Analog Audio I/O..... | 42 |
| 7.3.1 | DAC..... | 42 |
| 7.3.2 | ADC..... | 42 |
| 8. | CONTROLS..... | 43 |
| 8.1 | Measure Menu – MEASURE..... | 43 |
| 8.2 | Video Controls – VIDEO..... | 43 |
| 8.3 | Audio Controls – AUDIO..... | 44 |
| 8.4 | Meter Controls – METERS..... | 45 |
| 8.5 | Operating Conditions – STATUS..... | 46 |
| 8.6 | Engineering – ENG'ING..... | 47 |
| 8.7 | Calibration – CALIB..... | 47 |
| 8.8 | Configuration – CONFIG..... | 48 |
| 9. | TROUBLE SHOOTING GIUDE (FAQ)..... | 49 |
| 10. | INITIALISATION & ERROR CODES | 50 |
| 11. | MENU TREE..... | 51 |
| 12. | DOCUMENT REVISIONS | 52 |



List of Figures

| | |
|----------------------------------------------------------|----|
| Figure 1 VALID Rears (V16HR3C, V16HR3H, & V16HR3K) | 7 |
| Figure 2 V6821 PCB | 14 |
| Figure 3 V6822 PCB | 14 |
| Figure 4 Flash Memory Card | 16 |
| Figure 5 VALID Front Panels | 17 |
| Figure 6 VALID Broadcast System analysis | 22 |
| Figure 7 Group Channels & Naming | 25 |
| Figure 8 GLITS Tones | 26 |
| Figure 9 Frequency Spectra..... | 27 |
| Figure 10 ID Slot Timing..... | 29 |
| Figure 11 Sync signal timing..... | 30 |
| Figure 12 Audio Idents with staggered Segments..... | 30 |
| Figure 13 Four Channel Delay Meter and PPM Display | 31 |
| Figure 14 Eight Channel Delays..... | 33 |
| Figure 15 Eight Channel PPM Meters | 33 |
| Figure 16 V6821 Block Diagram | 34 |
| Figure 17 V6822 Block Diagram | 35 |
| Figure 18 GPI Relay Connections..... | 40 |

1. DESCRIPTION

1.1 GENERAL

VALID is a system for the Video and Audio Line-up and Identification of a broadcast link. It is to be used over a link while out of service or as a line-up signal before a contribution. It has two parts – a Generator which produces both the video and audio line up signals and a Reader which analyses them. While the combination allows the measurement of common video and audio parameters a special feature of VALID is to measure the relative timing of the video and audio signals. These timing errors are becoming increasingly common and appear to the viewer and listener as a Lip Sync error.

The VALID generator works in any of the High Definition television standards being used throughout the world and has been specifically designed to work over international links that may include high levels of compression and noise. It also works in both Standard definition formats (525/59.94 and 625/50) so is perfectly suited to the modern multi-format and multi-standard installation. It can work as a free running test signal generator or lock to an incoming SDI video or an external analogue reference. There is already an existing standard definition version of VALID that has been available for some years and this new HD VALID is fully compatible with it. This means that a HD VALID Reader will receive and understand an original SD Generator and vice versa. The reader automatically detects the input video standard. The reader makes certain measurements and makes them available on its front panel, over the DART remote control and puts meters on its video output.

The generator is normally two standard V1600 cards of which one generates the video signal while the other does the audio. With this arrangement the video output may contain the audio signals embedded within it but both analogue and digital outputs of the audio are available from the audio generator. The audio generator carries a Compact Flash card for storing captions and audio idents. If only the video card is used then it is only possible to produce embedded audio.

Similarly the reader is normally two standard cards of which one analyses the video signal while the other does the audio signals. If only the video card is used it is not possible to process external analogue and digital audio but only embedded audio. The reader normally puts PPMs onto the video, but this is not possible if only the video card is used, however it will still display the audio video timing measurements.

The video signal has several components. Colour bars are used to check levels, basic colorimetry and luminance/chrominance routing. A central generated circle shows how the aspect ratio has been correctly maintained or otherwise and it contains a rotating sweep which shows that the received signal is 'live' and has not been frozen in a Frame Store. Within the circle text describes the basic parameters of the originating signal, both video and audio. A four line caption can be added to the generator output to identify the specific transmission. This caption can be edited locally, from a remote control panel or loaded in from the Compact Flash card.

The audio signals are generally tone, but have different frequencies for each AES channel, and they have short gaps which are used for the timing measurements. It is important that the tone is generally continuous, but with gaps, rather than short tone bursts so it can be used with PPMs and VU meters for level checking. By having slightly different characteristics in the all audio channels the reader can check that there has been no swapping or mis-routing. It can also check if any channel has been inverted. These tones with the short gaps are referred to in this manual as Glits tones.

Both the generator and reader are fully controllable over the DART remote control system. For this there are two hardware panels available (the 1U V1605 and the 2U V1602) and a full Client-Server PC control system, known as Viewnet. While it is quite possible to use VALID on the small front panel the remote control systems make it much easier.



VISTEK V6821 / V6822 VALID Reader

There is a PC programme available for creating caption and audio idents and storing them on the Compact Flash card.

This manual describes the generator in detail and there is another complementary manual for the reader.

1.2 VIDEO STANDARDS

1.2.1 Supported Video Standards

The HD VALID reader module will output both SD and HD, although an FPGA re-load is required when switching between SD and HD. The supported standards are listed here.

| Tektronix Definition | SMPTE | Colloquial |
|-----------------------|------------|------------|
| 1920x1080/60/2:1 | 274M - 4 | 1080i60 |
| 1920x1080/59.94/2:1 | 274M - 5 | 1080i59 |
| 1920x1080/50/2:1 | 274M - 6 | 1080i50 |
| 1920x1080/30/1:1 | 274M - 7 | 1080p30 |
| 1920x1080/29.97/1:1 | 274M - 8 | 1080p29 |
| 1920x1080/25/1:1 | 274M - 9 | 1080p25 |
| 1920x1080/24/1:1 | 274M - 10 | 1080p24 |
| 1920x1080/23.98/1:1 | 274M - 11 | 1080p23 |
| | | |
| 1920x1080/24/1:1SF | RP211 - 15 | 1080sf24 |
| 1920x1080/23.98/1:1SF | RP211 - 16 | 1080sf23 |
| | | |
| 1280x720/60/1:1 | 296M | 720p60 |
| 1280x720/59.94/1:1 | 296M | 720p59 |
| 1280x720/50/1:1 | 296M | 720p50 |
| 1280x720/30/1:1 | 296M | 720p30 |
| 1280x720/29.97/1:1 | 296M | 720p29 |
| 1280x720/25/1:1 | 296M | 720p25 |
| 1280x720/24/1:1 | 296M | 720p24 |
| 1280x720/23.98/1:1 | 296M | 720p23 |
| | | |
| 1920x1035/60/2:1 | 260M | 1035i60 |
| 1920x1035/59.94/2:1 | 260M | 1035i59 |
| | | |
| 625/50/2:1 | 125/259M | 625i50 |
| 525/59.94/2:1 | 125/259M | 525i59 |
| | | |

2. INSTALLATION

2.1 REAR PANELS

All signal connections are provided via the rear panels. The V16HR3C single width rear module provides connectivity for the V6811 when using only embedded audio signals.

The V16HR3H double width rear module is used with the V6811 video module and the V6812 audio module, providing full video and external audio connectivity. The high density D-type connectors are used for both analogue and balanced digital audio. The larger D-type connector has 44 pins and is referred to in this manual as the HDD44 Connector. The smaller one has 26 pins and is referred to as the HDD26 connector. The smaller connector also carries the GPI connections

The V16HR3K double width rear module provides video and unbalanced AES audio connectivity for the V6811 and V6812. The GPI connections are on a small Molex connector.

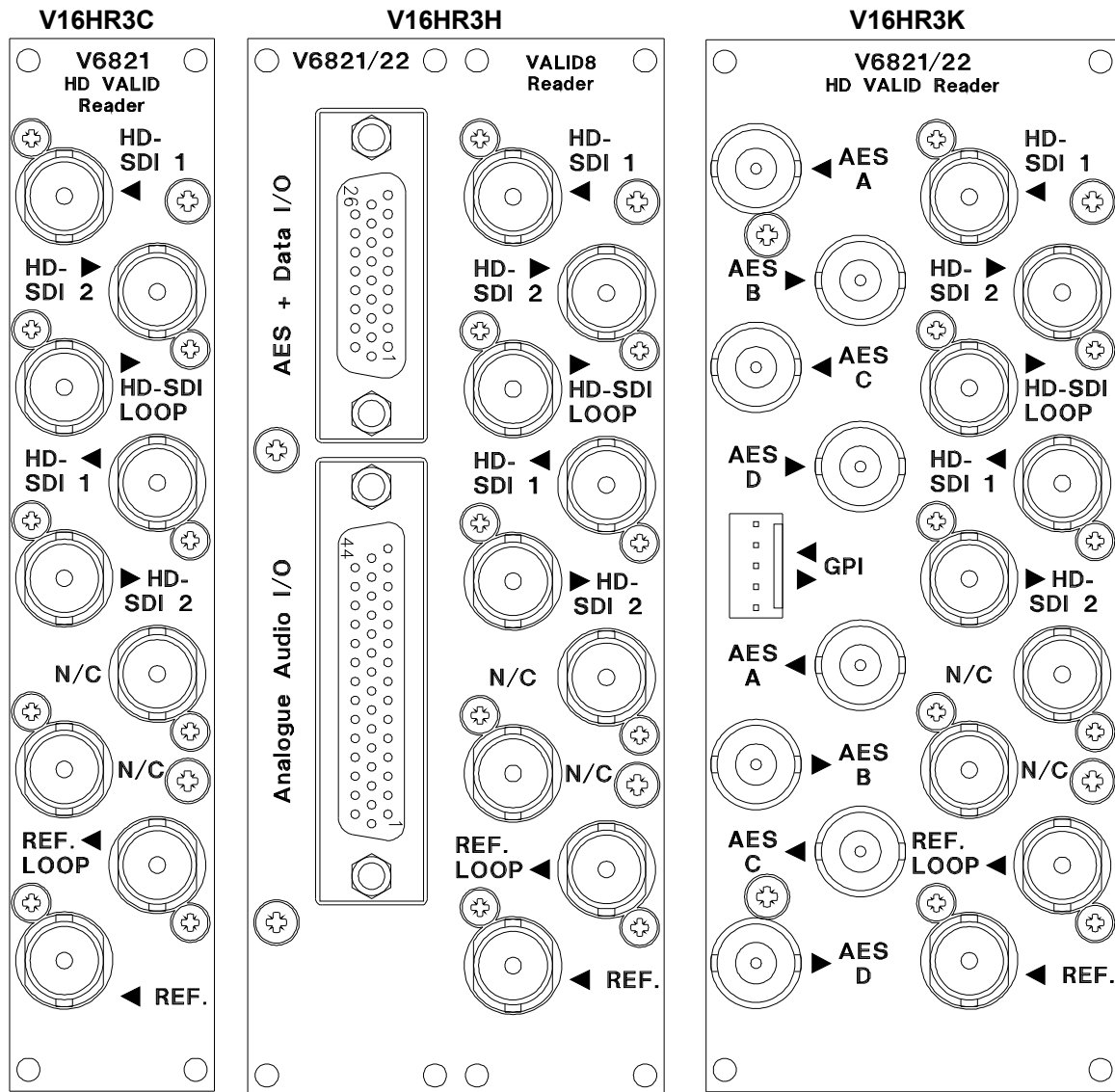

Figure 1 VALID Rears (V16HR3C, V16HR3H, & V16HR3K)



2.2 CONNECTIONS

2.2.1 Video Connections

Rear panel connections on the video side of the V16HR3H, V16HR3C, and V16HR3K rear panels:

| Connector | Type | Function |
|-------------|------|----------------------------------------------------------------------------|
| HD/SDI 1 | BNC | HD SDI Video I/P 1 |
| HD/SDI 2 | BNC | HD SDI Video I/P 2 |
| HD/SDI LOOP | BNC | HD SDI Buffered O/P |
| HD/SDI 1 | BNC | SDI O/P 1 |
| HD/SDI 2 | BNC | SDI O/P 2 |
| N/C | BNC | Do not connect |
| N/C | BNC | Do not connect |
| REF. LOOP | BNC | Reference Loop (Not Implemented) |
| REF. | BNC | Reference Input. Switch selectable termination on board. (Not Implemented) |

2.2.1.1 SDI Inputs

The SDI inputs must conform to either the SMPTE292M or SMPTE259M standards, which describe the Bit Serial Digital Interface for HD and SD operation respectively. If only one input is required then it should normally be connected to SDI 1. Unused inputs can be left open, it is however recommended to terminate unused inputs with a 75Ω Terminator to improve noise immunity. Signals of different frame-rates, resolutions or even a mixture of SD and HD standards can be connected to both inputs at the same time, however only one of the two inputs can be selected at any one time. Note that switching between different standards is neither instant nor glitch-free. This has to do with the necessity of the SDI de-serialiser hardware to lock to the newly detected standard. Furthermore, in case of an SD-to-HD switch over (or vice versa), the FPGA on the baseboard may have to be re-loaded. This process takes about 2 to 3 seconds.

The input selection is done on the **VIDEO : Source** menu.

2.2.1.2 SDI Reclocked & Buffered Output

This is always available, and is a relocked version of either SDI 1 or SDI 2, depending on the source selection. It is an unprocessed signal.

2.2.1.3 SDI Main Outputs

The main program synchronised/processed SDI output is available on two BNCs.

2.2.1.4 Video Reference

The reference input and loop have no function on the VALID reader module and should be left unconnected.



2.2.2 Audio Connections – V16HR3H

The V16HR3H double width rear provides additional I/O:

| Connector | Type | Function |
|------------------|--------|----------------------------------------------------|
| Analogue Outputs | HDD 44 | 8 Analogue Audio Outputs & 8 Analogue Audio Inputs |
| AES Outputs | HDD 26 | 4 AES Outputs & 4 AES Inputs |

The V6822 always shares a double width rear panel with the V6821. These are the V16HR3H which provides balanced analogue audio I/O and balanced AES audio I/O, and the V16HR3K which provides unbalanced AES audio only. Breakout cables which take the high density D-types on the V16HR3H rear to cable XLR connectors are available.

2.2.3 Audio Connections – V16HR3K

The V16HR3K double width rear provides the following additional I/O:

| Connector | Type | Function |
|----------------|--------|------------------------------------------------------------------------------------|
| AES A to D In | BNC | 4 AES Unbalanced Inputs |
| AES A to D Out | HDD 26 | 4 AES Unbalanced Outputs |
| GPI I/O | Molex | Pin1 GPI Input 1 Pin2 GPI Input 2 Pin 3 GND Pin 4 +5V Pin 5 GPI Output |

On the V16HR3H rear panel there is a 44 way HDD connector in the same footprint size as a standard 25 way D type connector. It is used for all the balanced analogue audio connections, of which there are 8 input channels and 8 output channels. Also on the same rear panel there is a 26 way HDD connector in the same footprint size as a standard 15 way D type connector. It is used for all the balanced AES audio connections, of which there are four input AES and four output AES signals.

If the HDD socket is to be used for audio and connected with multi-way cable it is recommended that the audio pairs, both analogue and digital, are individually screened.

On the V16HR3H rear panel the signals to and from the pins on the HDD44 Analogue I/O connector and the HDD26 Digital I/O connector are as shown in the following tables.

Note: Due to the VALID reader only operating on 8 channels at a time all references are made to channels A to D in the tables although the actual channels that are output may be either A to D or E to H depending on the setting of **AUDIO : Channels**.



VISTEK V6821 / V6822 VALID Reader

2.2.4 HDD44 Connector - Analogue Audio I/O

| Signal Group Label | HDD44 Pin | Signal Function | Notes |
|----------------------|-----------|----------------------|-----------------------------------------------------------------------------------------------------------------------------------------------------------------------------------------------------------------------------------------------------------------------------------------------------------------------------------------------------------------------------------------------------------------------------------------------------------------------------------------------------|
| Audio 1 AL in ← | 14 | Input Analog AL Pos | <p>These are electronically balanced (transformerless) differential analog audio inputs with high Zin of 20kΩ.</p> <p>All inputs are a.c. coupled</p> <p>Maximum analog input level (MAL) is settable on the V6811 module in 1dB increments from +12dBu to +24dBu</p> <p>To apply a single-ended signal, connect the 'hot' from the source to the 'Pos' input, and the 'Neg' input to GND = source GND.</p> |
| | 44 | Input Analog AL Neg | |
| | 15 | Input Analog AL Gnd | |
| Audio 2 AR in ← | 13 | Input Analog AR Pos | |
| | 43 | Input Analog AR Neg | |
| | 28 | Input Analog AR Gnd | |
| Audio 3 BL in ← | 12 | Input Analog BL Pos | |
| | 42 | Input Analog BL Neg | |
| | 26 | Input Analog BL Gnd | |
| Audio 4 BR in ← | 11 | Input Analog BR Pos | |
| | 41 | Input Analog BR Neg | |
| | 40 | Input Analog BR Gnd | |
| Audio 5 CL in ← | 9 | Input Analog CL Pos | |
| | 39 | Input Analog CL Neg | |
| | 10 | Input Analog CL Gnd | |
| Audio 6 CR in ← | 8 | Input Analog CR Pos | |
| | 38 | Input Analog CR Neg | |
| | 24 | Input Analog CR Gnd | |
| Audio 7 DL in ← | 7 | Input Analog DL Pos | |
| | 37 | Input Analog DL Neg | |
| | 21 | Input Analog DL Gnd | |
| Audio 8 DR in ← | 6 | Input Analog DR Pos | |
| | 36 | Input Analog DR Neg | |
| | 5 | Input Analog DR Gnd | |
| Audio 9 DR out ⇒ | 4 | Output Analog DR Pos | <p>These are electronically true balanced (transformerless) differential outputs with low output impedance of Zout = 50Ω.</p> <p>All outputs are dc coupled.</p> <p>Maximum analog output level (MAL) is settable on the V6811 module in 1dB increments from +12dBu to +24dBu</p> <p>To obtain a single-ended signal, connect the 'Neg' output to GND and connect the 'Pos' output to the 'hot' of the single-ended destination input.</p> <p>Maximum output level with single ended is +18dBu.</p> |
| | 34 | Output Analog DR Neg | |
| | 19 | Output Analog DR Gnd | |
| Audio 10 DL out ⇒ | 3 | Output Analog DL Pos | |
| | 33 | Output Analog DL Neg | |
| | 19 | Output Analog DL Gnd | |
| Audio 11 CR out ⇒ | 2 | Output Analog CR Pos | |
| | 32 | Output Analog CR Neg | |
| | 16 | Output Analog CR Gnd | |
| Audio 12 CL out ⇒ | 1 | Output Analog CL Pos | |
| | 31 | Output Analog CL Neg | |
| | 16 | Output Analog CL Gnd | |
| Audio 13 BR out ⇒ | 23 | Output Analog BR Pos | |
| | 22 | Output Analog BR Neg | |
| | 35 | Output Analog BR Gnd | |
| Audio 14 BL out ⇒ | 18 | Output Analog BL Pos | |
| | 17 | Output Analog BL Neg | |
| | 35 | Output Analog BL Gnd | |
| Audio 15 AR out ⇒ | 20 | Output Analog AR Pos | |
| | 25 | Output Analog AR Neg | |
| | 29 | Output Analog AR Gnd | |
| Audio 16 AL out ⇒ | 30 | Output Analog AL Pos | |
| | 27 | Output Analog AL Neg | |
| | 29 | Output Analog AL Gnd | |

Note: Pin 1 is at the bottom

2.2.5 HDD26 Connector - Digital Audio I/O and signalling

| Signal Group Label | HDD26 Pin | Signal Function | Notes |
|--------------------|-----------|--------------------|-----------------------------------------------------------------------------|
| Audio 1_2 | 9 | Input AES A Pos | These are balanced transformer coupled digital inputs to AES3. Zin = 110Ω |
| AES A in ⇐ | 18 | Input AES A Neg | |
| Audio 2 | 8 | Input AES B Pos | |
| AES B in ⇐ | 17 | Input AES B Neg | |
| GND | 26 | GND | Unbalanced AES inputs are not available on this rear panel |
| Audio 3_4 | 7 | Input AES C Pos | |
| AES C in ⇐ | 16 | Input AES C Neg | |
| Audio 4 | 6 | Input AES D Pos | |
| AES D in ⇐ | 15 | Input AES D Neg | |
| GND | 25 | GND | |
| Audio 5_6 | 5 | Output AES A Pos | These are balanced transformer coupled digital outputs to AES3. Zout = 110Ω |
| AES A out ⇒ | 14 | Output AES A Neg | |
| Audio 6 | 4 | Output AES B Pos | |
| AES B out ⇒ | 13 | Output AES B Neg | |
| GND | 1 | GND | Unbalanced AES outputs are not available on this rear panel |
| Audio 7_8 | 3 | Output AES C Pos | |
| AES C out ⇒ | 12 | Output AES C Neg | |
| Audio 8 | 2 | Output AES D Pos | |
| AES D out ⇒ | 11 | Output AES D Neg | |
| Audio 9 | 20 | Reserved | Reserved. Usage TBA |
| AES REF in ⇐ | 19 | Reserved | |
| Misc. 1 | 24 | Input GPI_1 (TBA) | Reserved. Usage TBA |
| GPI ⇐ | 23 | Input GPI_2 (TBA) | |
| GND | 10 | GND | |
| Misc. 2 | 22 | Output GPO_1 (TBA) | Reserved. Usage TBA |
| GPO ⇒ | 21 | Output GPO_2 (TBA) | |

Note: Pin 1 is at the bottom

2.2.6 Breakout Cables and Panels

Pro-Bel can supply prefabricated Breakout Cables for use with the HDD44 and HDD26 connectors.

The following cables are available:

| Part No. | Description | Drawing Ref. | Notes |
|-----------|----------------------------------------|--------------|-------------------------|
| V6905 | V6812/V6822 HDValid HDD26 to XLR | 130-4681 | 4 x AES in, 4 x AES out |
| V6906/IN | V6812/V6822 HDValid HDD44 to XLR SKT | 130-4682 | 8 x Analog IN only |
| V6906/OUT | V6812/V6822 HDValid HDD44 to XLR (PLG) | 130-4683 | 8 x Analog OUT only |

There is also a break out panel, V6907, which connects to the HDD connectors with ribbon cable and gives more conventional connectors on a 1U panel.



VISTEK V6821 / V6822 VALID Reader

The following are available:

| Part No. | Description | Notes |
|-------------|-----------------------------------------------|------------------------------------------------------------------|
| V6907/BAL | HDD44 and HDD26 to Phoenix connectors | 8 x Analogue In 8 x Analogue Out 4 x AES in 4 x AES out |
| V6907/UNBAL | HDD44 and HDD26 to Phoenix and BNC connectors | 8 x Analogue In 8 x Analogue Out 4 x AES in 4 x AES out |

2.3 MODULE AND ENVIRONMENTAL SPECIFICATIONS

| Parameter | Environmental Specification |
|-----------------------------|----------------------------------------------------------------------------------------------------------------------------------|
| Module Size (V6821) | Standard V1600 range module – 100mm x 270mm. Fits in V1606 3U rack, V6011 '1-Box' or V6012 TwoBox |
| Module Size (V6821 + V6822) | Two standard V1600 range module – 100mm x 270mm(each) Fits in two slots on a V1606 3U rack, or V6012 TwoBox |
| Rear Panels | V16HR3C Single Width Rear (V6821 only) V16HR3H Double Width Rear (V6821 + V6822) V16HR3K Double Width Rear (V6821 + V6822) |
| Operating Voltage | +9 .. +18V |
| Operating Temperature | 0°C to +40°C. Cooling is from the V1606 rack. |
| Power Consumptions | V6821 10W V6822 12W |

2.4 SIGNAL SPECIFICATIONS

| Signal | Type | Comments |
|-----------------------|---------------------------------------|----------------------------------------------------------------------------------------------------------------------------------------------------------------------------------------------------------------------------------------------------------------------------------------------------------------------------------------------------------------------------------------------------------------|
| Video Inputs | 75Ω BNC | Input Format: SMPTE259M or SMPTE292M Input Impedance: 75 Ohm Return Loss: > 15dB, 5MHz – 1.5GHz Equal. Cable Length: 0-250m @ 270Mbps 0-100m @ 1.5Gbps |
| Video Outputs | 75Ω BNC | Output Format: SMPTE259M or SMPTE292M Output Impedance: 75 Ohm Return Loss: > 15dB, 5MHz – 1.5GHz Jitter Performance: < 0.2UI p-p (Timing @ 270Mbps) < 0.2UI p-p (Alignment @ 270Mbps) < 1UI p-p (Timing @ 1.485Gbps) < 0.2UI p-p (Alignment @ 1.485Gbps) Amplitude: 800mV p-p (terminated) Drive Capability: > 250m @ 270Mbps (Belden 8281) > 100m @ 1.5Gbps (Belden 1694A) |
| Video Reference Input | Bi-Level or Tri-Level | 1V Composite video, but Black & Burst is recommended. Tri-Level sync as per SMPTE274M or 296M. |
| Sync Pulse | LVTTTL with +/- 24mA drive capability | Not used on the V1621/22 combination |
| Audio, Digital (AES) | Balanced | Zin = 110Ω Zout = 110Ω Input Sample rate 32–192kHz Output Sample rate 48kHz |
| Audio, Digital (AES) | Unbalanced | Zin = 75Ω Zout = 75Ω Input Sample rate 32–192kHz Output Sample rate 48kHz |
| GPI Input | 0V to 5V | Note: no on-board voltage protection |
| GPI Output | LVTTTL with +/- 24mA drive capability | |

2.5 INSERTION DELAY

Video insertion delay is less than 10 us.

Audio insertion delay is 4 ms including the delay through the Sample Rate Converters (SRC).

By design the audio insertion delay for both analogue and digital audio is constant. Embedded audio can only be passed through as part of the video so is subject to the same delay as the video.

2.6 HARDWARE

The figures below show diagrammatically the printed circuit boards along with certain other components of interest. In particular it shows the position and orientation of links and switches which set up the operation modes and the location of the sub-modules.

The FLASH Memory location is shown, as it is the component that would need to be changed as a result of any software upgrade on either module in the field. The FLASH Memory is a proprietary module and can only be obtained from Pro-Bel. Although the FLASH Memory has a polarising key, care must still be taken when refitting the FLASH Stick to ensure that it is inserted the right way round and pushed fully 'home'.

2.6.1 V6821 PCB

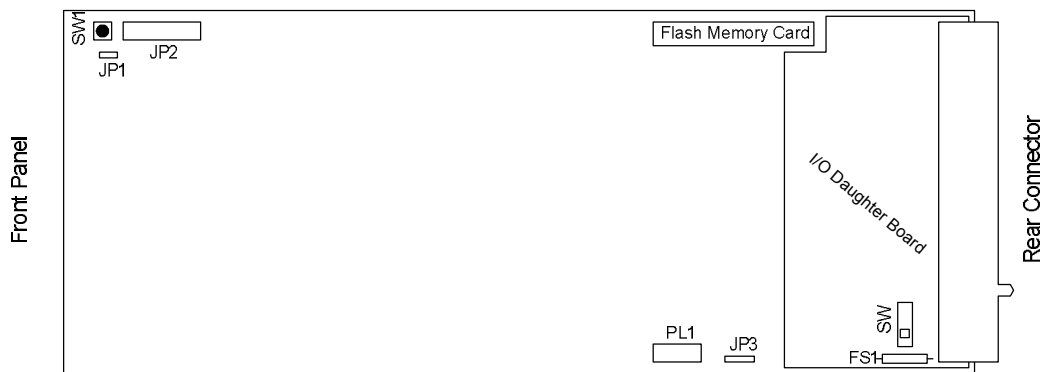

Figure 2 V6821 PCB

2.6.2 V6822 PCB

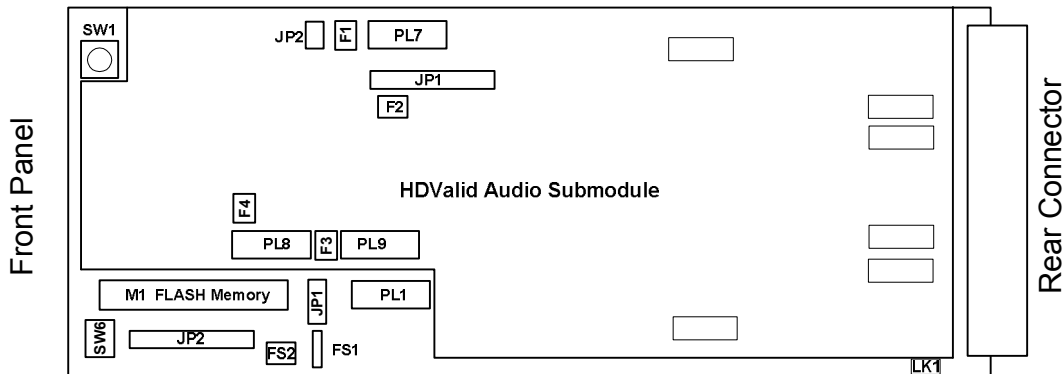

Figure 3 V6822 PCB

2.6.3 V6821 Links and Switches

The purposes of the links and switches are shown in the following table.

| ITEM | Title | Comments |
|------|----------------|-----------------------------------------------------------------------|
| SW1 | RESET | Used to reset the internal microcontroller. |
| JP1 | Debug | For development and test use only. (May not be fitted) |
| JP2 | H8 Program | For development and test use only. (May not be fitted) |
| PL1 | JTAG Port | Never used in operation. (May not be fitted) |
| JP3 | JTAG Enable | For Test. Fit in 2-3 position. |
| SW | Video REF Term | Slider up – Terminated with 75Ω Slider down – Hi-Z (un-terminated) |

2.6.4 V6822 Links and Switches

The purposes of the links and switches are shown in the following table.

| ITEM | Title | Comments |
|------------------|----------------------------------|--------------------------------------------------------------------------------|
| SW 1 | RESET switch | Used to reset the internal microcontroller and DSP. |
| SW6 | DEBUG switch | For development and test use only. Both switches should always be set 'north'. |
| PL 1 | JTAG Connector (baseboard) | For development and test use only. May not be fitted |
| PL7 | JTAG Connector (submodule) | For development and test use only. May not be fitted |
| JP 1 (baseboard) | JTAG enable (baseboard) | For development and test use only. May not be fitted |
| JP2 (submodule) | JTAG enable (submodule) | For development and test use only. May not be fitted |
| JP2 (baseboard) | H8 Programming Connector | For development and test use only. May not be fitted |
| JP1 (submodule) | Beck SC123 Programming Connector | For development and test use only. May not be fitted |
| LK 1 | Not used | May not be fitted. |
| PL8 | Header for Internet connectivity | For future development. May not be fitted |
| PL9 | Header for USB connectivity | For future development. May not be fitted. |

2.6.5 V6821 Fuse

There is a single fuse on the IO sub-module on the V6821. It is in series with the main input supply and will only blow for a serious short circuit fault, probably on the input of the main PSU sub-module.

| | | |
|-----|-----------------------|----------------------------------------------------------------------|
| FS1 | Fuse 3 Amp Wire ended | In series with the DC input to the module on the I/O daughter board. |
|-----|-----------------------|----------------------------------------------------------------------|

2.6.6 V6822 Fuses

There are several fuses on the V6822:

| | | | |
|------|--------------------------|--|-------------------------------------------------------------------------|
| FS 1 | Fuse 2 Amp Wire ended | | In series with the +15V input to the module. |
| FS2 | Resettable fuse 0.5A SMD | | Protects 3V3 power feed to JP2 programming connector. Factory use only. |
| F2 | Resettable fuse 0.5A SMD | | Protects 3V3 power feed to JP1 programming connector. Factory use only. |
| F3 | Resettable fuse 0.5A SMD | | Protects 3V3 power feed to JP8 and JP9. Factory use only |
| F4 | Resettable fuse 0.5A SMD | | Protects 5V power feed to JP8 and JP9 headers. Factory use only |

2.6.7 Flash Memory Card

The Flash Memory Card stores the firmware for the Microcontroller and the FPGA and is essential for the operation of the module. If this card is missing, the front panel display will come up with an error message (ERROR 10). The Flash Memory Card sits in a socket with a location peg to the right. In case of a firmware upgrade make sure that the replaced card sits firmly and straight in the socket with the location peg mating with the positioning hole on the baseboard.

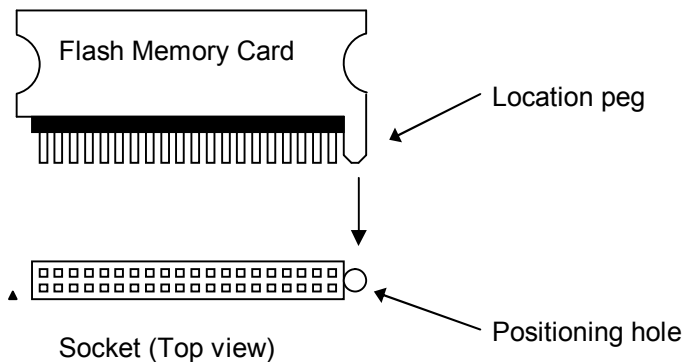

Figure 4 Flash Memory Card

The Flash Memory Card is re-programmable. Customers are kindly asked not to throw it away after having upgraded a module with a newer firmware version but to return it to ProBel.

2.7 FRONT PANELS

The front panels are similar to other complex V1600 types. They provide the user with total control and monitoring of the unit without the need to consult manuals and read unlabelled indicators.

The front panel of the V6821 and V6822 are shown below illustrating the location of all the front panel switches and displays.

All control of the V6822 is through the V6821.

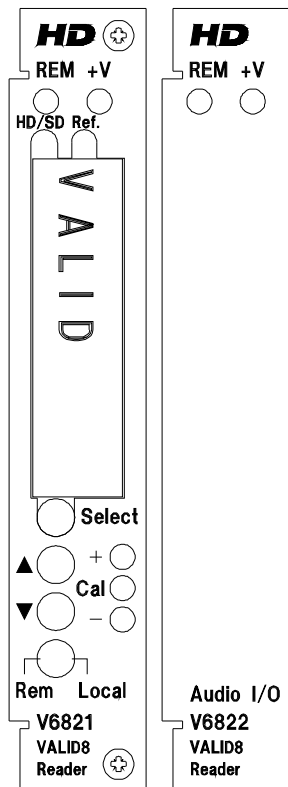

Figure 5 VALID Front Panels

Instructions on how to use the menu system on the front of the V6811 are given in section 3.1

2.7.1 LEDs & Switches

- +V** When lit indicates that power is applied to the module, and the main on-board regulator is working.
- REM** Flashes during DART communications, can indicate a DART remote control problem if never lit.
- Ref.** When a black flash sequence is detected this LED will light, and blip every flash.
- +/- Cal** Indication of the current menu item's value in relation to the calibrated or default value.

Select/Up/Down are menu controls and are explained in detail in section 3.1.

Rem/Local Switched the module into remote or local control modes.



2.8 MODULE PLACEMENT

The V6821 should always be positioned on the left of the V6822 as shown in Figure 5.

Although the main connectors of both modules are the same type they are in slightly different positions, so if you try to force either card into the wrong slot they could be damaged.



3. SYSTEM CONTROL

3.1 LOCAL CONTROL

3.1.1 Start up

Local control and monitoring of the modules is done through the front panel of the V6821 with its eight character LED display and three control buttons **Select**, **▲** and **▼**. There are three LEDs which also contribute to the status indication; these are labelled **+**, **Cal** and **-**.

After power up and having successfully passed the power-on-self test, the display will start at the top level and show the unit type and any options that are included. The display will be one of these:

| Unit type | Password protected Option(s) |
|-----------|---------------------------------|
| V6821 | <i>No options are available</i> |

At present there are no Options available for the V6821 or V6822. Options are usually shown as a 2 letter code, for example VP for Video Proc amp. If there are more options than can be shown on the display then the last character will be '+', and the **▼** button can be pressed to show other options.

3.1.2 Menu Control

The **Select**, **▲** and **▼** buttons are used to manoeuvre around the menu system. The menu structure has five levels and the **Select** button is used to go up and down the structure. The **▲** and **▼** buttons are used to move between selections or to adjust a parameter depending on which sort of menu is displayed. The five levels are as follows:

| | |
|-----------|------------------------------------------------------------------------------------------------------------------------------------------------------------------------------------------------------------------------------------------------------------------------------------------------------------------------------------------------------------------------------------------------------------------------------|
| Sleep | Display is blank (except for Banner warnings). |
| Top Level | As above, e.g. V6821 |
| Main Menu | The Main menu items, such as VIDEO , STATUS , ENG'ING etc. These items are all in Upper Case. |
| Sub Menu | Menu items under each main heading, such as Aud I/P or Channels under the AUDIO main menu. These items are all in Sentence Case (generally lower case but with upper case first letters). |
| Parameter | The lowest level under the Sub Menu, often in lower case, is used to actually adjust a parameter. The display will depend on the actual parameter and may be a value such as +0.00dB for a gain or ON or OFF for a switch variable. There is usually a title to describe the variable and a small icon in the left hand character position, but 8 characters cannot provide for a detailed description. |

To move down a level just press the **Select** button briefly; then press either the **Select** button again to go down another level or the **▲** and **▼** buttons to move around the options within a level.

To move up a level press and hold the **Select** button for about half a second which will move up one level. If you continue to hold the **Select** button then it will move up a level every half a second until it reaches the Sleep level (one above the Top Level).

A complete list of all the menus is given in Section 8.



VISTEK V6821 / V6822 VALID Reader

3.1.3 Menu Examples

This section has examples of how to manoeuvre through the menu system. The first one starts with the unit in its 'sleep' mode where the display is blank, and then proceeds to set the source to the second input (I/P 2).

| Action | Display | Comments |
|--------|----------------|---------------------------------|
| Select | v6821 | Top Level |
| Select | MEASURE | The first Main Menu in the list |
| ▼ | VIDEO | The Main Menu we want |
| Select | Source | The Sub Menu we want |
| Select | I/P 1 | |
| ▲ | I/P 2 | Set it as we want it |

3.1.4 Sleep

If the front panel is not used for a certain amount of time then the display will automatically go into a sleep mode when it will be blank. Pressing any of the buttons will cause it to 'wake up' back into the top level. The time delay before the unit slips into sleep mode can be set up using the **ENG' ING : Sleep** menu.

The brightness of the display can also be adjusted using the **ENG' ING : LEDLevel** menu.

3.2 REMOTE CONTROL

In addition to being controlled with the menu system on the front panel the V6821 can also be controlled over the DART remote control system. For this it should be fitted into a rack which also contains a Rack Controller. The Rack Controller provides an interface between all the units in the rack and the external DARTNET network.

All control of the units, both remote and local is, done through the V6821.

Various controlling devices are available for accessing units on the DARTNET. There are two hardware control panels, the V1602 and the V1605 which are 2U and 1U units respectively. There is also Viewnet which is a sophisticated Client Server interface. It is also possible to have third party software written to interact with DARTNET. The details and specification of the DART interface are described elsewhere.

It is important that the DART controlling device is sufficiently up to date to control the V6811 and V6812. In particular the V6811 is a Class 7 device and therefore must be fitted to a rack with the new V6801 type Rack Controller and the Rack Controller software must be version R25 or later. The V6801 type Rack Controller can be easily identified by the 3 segment display on its front which will normally show the Rack address; for example A02. If the recessed function button (not the reset button) is pressed 5 times the display will show the version number, e.g. **r25**.

There are separate settings for the unit when operating in Local and Remote control modes. This means that if the unit is changed between Local and Remote mode then the settings may change. The advantage of this is that if the unit has been set up locally and the operator inadvertently changes to Remote mode (which probably has different, or even default, settings) the local settings are not lost. There could be a disadvantage in that once the unit has been set up remotely it cannot be switched to Local without causing a disturbance.

When in Remote Control the front panel menu system is still active but is only used to monitor the status of the unit. It cannot be used to change anything.

4. VALID SYSTEM

4.1 OVERVIEW

With the amount of video and audio processing in modern broadcast systems the timing of the audio to the video is always a consideration. Whether simply synchronising video to a system reference or routing via MPEG uplinks and downlinks the potential of the audio and video being subjected to a different amount of delay exists at every stage.

VALID was conceived to provide a simple to use, and simple to implement solution to measure the difference in the audio to video timing in a broadcast system, alleviating the need for an operator to manually adjust the timing every time the system configuration changes, and through trial and error getting the lip-sync 'nearly right'.

The VALID solution measures the audio to video timing without the need to know anything about the system which it is to analyse. The VALID test signal can be subjected to most video and audio processing functions such as standards conversion, aspect ratio conversion, compression, audio gain adjustments, audio conversion (analogue to digital, and digital to analogue conversion). So the VALID test signal can enter the broadcast system, then analyse the audio to video timing at multiple signal destinations subjected to different processing paths.

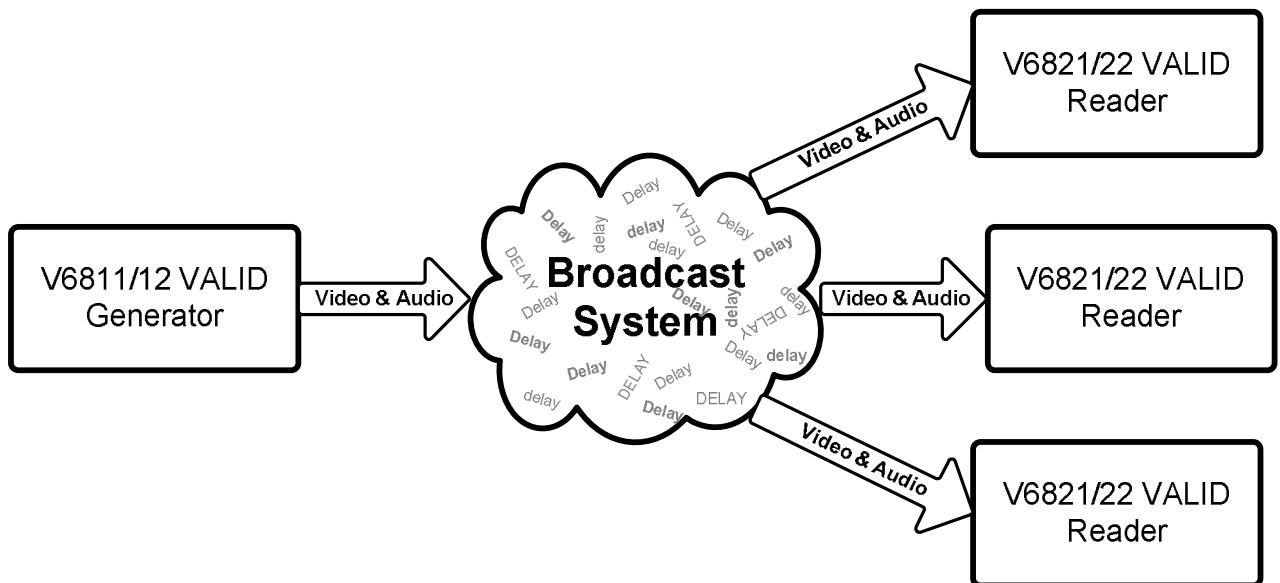

Figure 6 VALID Broadcast System analysis

But the VALID system is more than a lip-sync measurement device. With VALID it is possible to detect a frozen picture, audio inversion, channel swaps, and down-mixed channel pairs to name a few.

A general principle of the relative time measurements is to put in some kind of video and audio markers, or time stamps, at the generation end. When the markers are detected at the receiving end the relative time positioning can be measured. In the case of VALID the video markers is the black cross that is inserted every four seconds (usually referred to as the Black Flash), and the audio markers are the gaps in the tone that's start off with an exact timing relationship to the black flash.

The following paragraphs will discuss some of the key elements of the VALID generator test signal, and the measurements possible on the VALID reader.

4.2 TIME STAMPS

In VALID the video time stamp is a short duration Black Cross on the stationary, or quasi-stationary, background test pattern. In most standards this is repeated precisely every 4 seconds, but for any standards with an NTSC type field rate, such as 59.94Hz, the repetition rate is actually 4.004 seconds. This difference of 4ms is compensated for in the reader processing. The black flash is not simply a single field pulse but has proper temporal anti-aliasing. This improves the system performance when the signal undergoes any temporal processing, such as standards conversion.

The audio time stamp is gaps in otherwise continuous tone. All the left channels (sometimes called Channel 1) have a single gap whose start is exactly coincident with the temporal centre of the black flash. The right channels have two gaps slightly later than the left channel gap. This makes it much easier to do a listening stereo channel identification, and checking for mono.

4.3 VIDEO

4.3.1 Test Patterns

A number of background test patterns can be generated internally by the V6811 including 100% Bars, 75% Bars, and SDI Matrix. If a preferred test pattern is not provided by the V6811 the test pattern can be input to the V6811 through either of the SDI inputs. All the on-screen objects, the captions and the black flash, can still be overlaid.

All the delay measurements can still be performed with an external test pattern as long as it is static, and does not obscure the black flash with large black areas of screen.

4.3.2 Caption ID Text

Video caption idents are a set of 4 captions each of which can have its size, position and colour set by the user. There are three sizes, twelve vertical positions (they are always centred horizontally) and eight choices of colour. All these can be set either front the front panel or remotely over DART.

With the V6812 board captions can be loaded from a Compact Flash card which can store up to 63 sets of captions which can be loaded into VALID.

The caption text can be keyed into any test pattern or the external input and can individually be turned on and off.

The caption text can be edited both locally on the front panel and remotely over DART..

4.3.3 Timing Circle

A precisely dimensioned circle may be overlaid over the output video. The circle is exactly proportioned for the current aspect ratio, and if correctly displayed should be circular. In the HD standards the circle is always drawn for the 16:9 aspect ratio, but in SD there is a choice. It can be either 4:3 or 16:9 depending on the service required. In fact in SD there are two completely different patterns for these two cases.

The centre circle usually has a moving annulus, which is either a rotating greyscale or a series of red or green sectors. The movement is essential at the receiving end to show that the signal is 'live' and has not been frozen in a frame store.



VISTEK V6821 / V6822 VALID Reader

The red and green sectors have been positioned to exactly coincide with the tone gaps briefly discussed above and to be described in detail in section 1.1. The red sector corresponds with gap in the left channel, and the two green sectors with the two gaps in the right channel. The choice of red and green for left and right was made to match the international convention for navigation lights.

4.3.4 Black Cross Flash

For audio video timing measurements to be made with a V6821 VALID reader, both audio and video signals are time marked. The black flash is the key signal for the video timing measurement. VALID generates a spatially and temporally shaped black cross over a number of video fields. This shaping allows the video to be subjected to various filtering operations and still maintain the important timing signal. At the VALID reader complex detection logic identifies the black flash and locates its true sub-field timing. The VALID reader can then calculate the delay between this point and the audio's timing signal.

4.3.5 VALID Synchronisation

Multiple VALID generators can be co-timed using the sync output and input. A co-axial cable should link the Sync Out from the master to the Sync In of the slave. The slave unit will then lock its 4 second sequence to the Sync In and provide its own Sync Out for any other generators.

Since the Sync Out signal is locked to the 4 second sequence it can also be used to trigger an external audio identification generator.

4.3.6 Video Synchronisation

The generated video can be synchronised to either an SDI input or an external reference. Usually an external SDI signal will be used, and then the generator can be switched between the external video and the generated video with no disturbance. If no external SDI signal is connected then the reference can be used. If there is no reference then the generator will free run.

The precedence for the reference is:

- 1 Input SDI Video
- 2 External Reference
- 3 Free Run

Note that there is no selection for this. The reference is automatically selected following the precedence above.

The VALID generator is **not** a Frame Synchroniser. Even if it has an SDI input and a reference connected to it it will not lock the input to the reference.

4.4 AUDIO

4.4.1 Audio Channel Naming

When discussing the audio channels we refer to them by a naming convention that is derived from the order in which audio is embedded into video. It is possible to embed 4 groups of audio, each group consisting of 4 audio channels typically treated as 2 stereo channels. This gives us a possible 16 mono channels, or 8 stereo channels. The naming convention here assigns a letter to the stereo channel and a number (1 and 2) to differentiate the two channels in the stereo pair. The order in which the letters are assigned is the order they are typically embedded, from 'A', being the first stereo channel in group 1, to 'H', being the second channel in group 4. The '1' and '2' are typically the left and right channels of a stereo pair as shown in Figure 7.

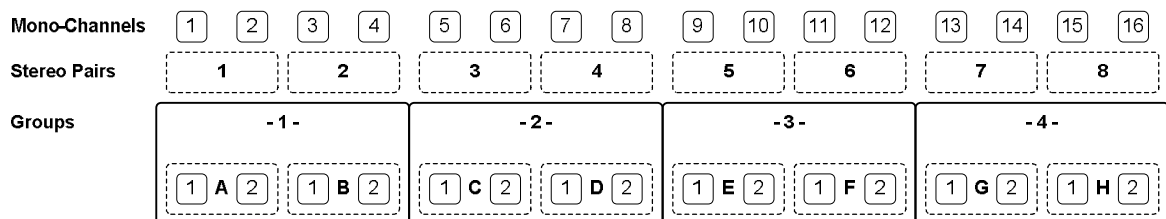

Figure 7 Group Channels & Naming

4.4.2 Audio Groups

The VALID system has been designed to identify, and so distinguish between, all 8 stereo (16 mono) audio channels using a combination of the tone gaps and different frequencies. With embedded audio this corresponds to the maximum of 4 groups. However the V6811/12 can only generate 4 pairs of audio at any one time, which corresponds to two groups. These are always grouped as audios A-D or E-H and the groups as 1&2 or 3&4. The V6821/22 combination is the same.

4.4.3 Audio Tones

The V6811 test-tone generator generates 4 stereo tones that can be embedded into the output video. When the V6812 is used the tones are also available as AES and analogue audio. The user can select to generate tones A to D or E to H. This selection determines the frequencies of the tones and the groups on to which they are embedded (A to D on Groups 1 and 2, and E to H on Groups 3 and 4). All 8 possible tones are generated at unique frequencies with a short gap in the left channel and two short gaps in the right channel (see Figure 8 and (b) in Figure 9 below).

4.4.4 Audio Channel Detection

Left (Alpha1) and right (Alpha2) channels are identified by a sequence of short breaks in the tone as shown in Figure 8. Also shown, at the bottom of the diagram, are representations of the rotating circle inset. The colour shown is the colour observed at the top (12 o'clock) position on the circle through the audio sequence.

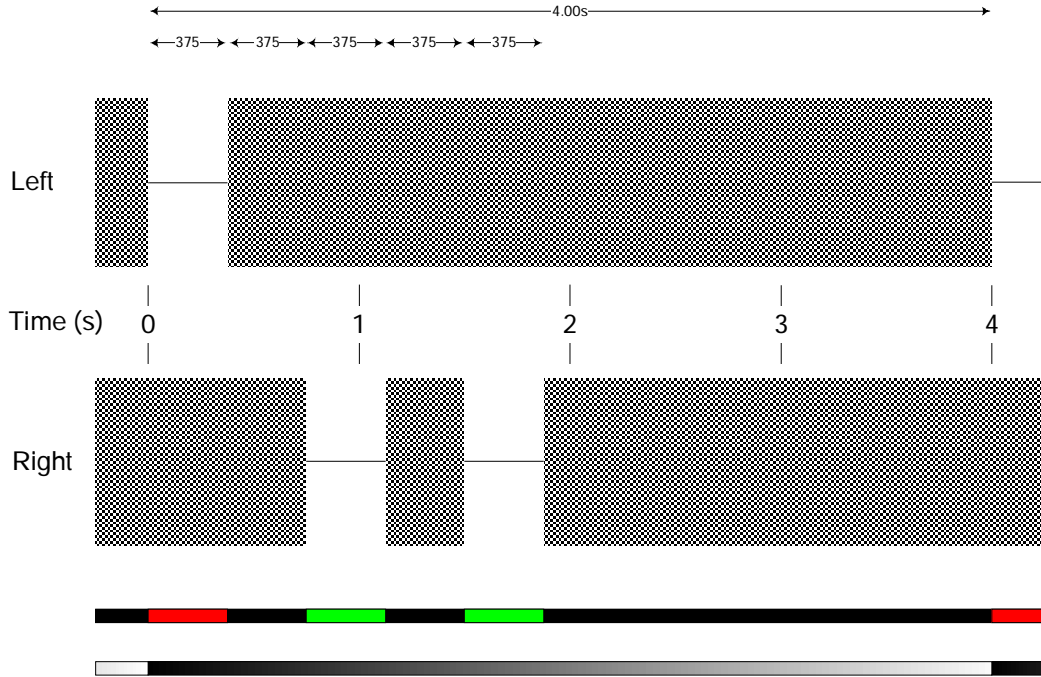

Figure 8 GLITS Tones

It is the gaps in the audio signal that are detected on the VALID reader as part of the audio to video delay measurement.

In order to avoid automatic muting by downstream audio devices (and subsequent 'soft restart' which could cause problems at the receiver end), the audio breaks are not complete silence, the tone is reduced in level by 60dB.

It should be noted that, whatever mode of operation the unit is in, the same audio will be produced at every audio output of the unit, for example, any audio coming from the analogue output (if V6812 fitted), will also be embedded into the out-going SDI stream if the V6811's audio multiplexer is enabled.

In the default mode of operation, the unit outputs Glits-tone with a VALID test pattern. The tone may periodically be interrupted by an internally or externally generated voice ident.

4.4.5 Identifying V1681 and V6811 Tones

The Valid reader has a frequency discriminator for each channel in order to detect channel swaps.

The V1681 original SD Valid generator only generated two tones (A and B) at 997kHz and 440Hz. The HD generator generates four tones at any one time but at a different frequency for A to D and E to H. The tones for the SD generator and HD generator are depicted in the frequency spectrums (a) and (b) below. As can be seen the selection of tones for B, D, F and H are close to the SD generators B tone, and A, C, E, and G are close to the SD generators A tone. The frequency discriminator in the SD reader has a wider envelope than the HD reader as can be seen in the frequency responses depicted in (c) and (d) below. By separating the frequency of the tones in the two types of generator in this way we allow the SD reader to detect tones B, D, F and H from the HD generator as channel B, and A, C, E, and G as channel A. Also when the SD generator is used with the HD reader we can even tell the tones are coming from an SD generator. Knowing this, only swaps of two channel pairs can be detected thus we detect the tones as X and Y to differentiate them from A and B as generated by a HD generator.

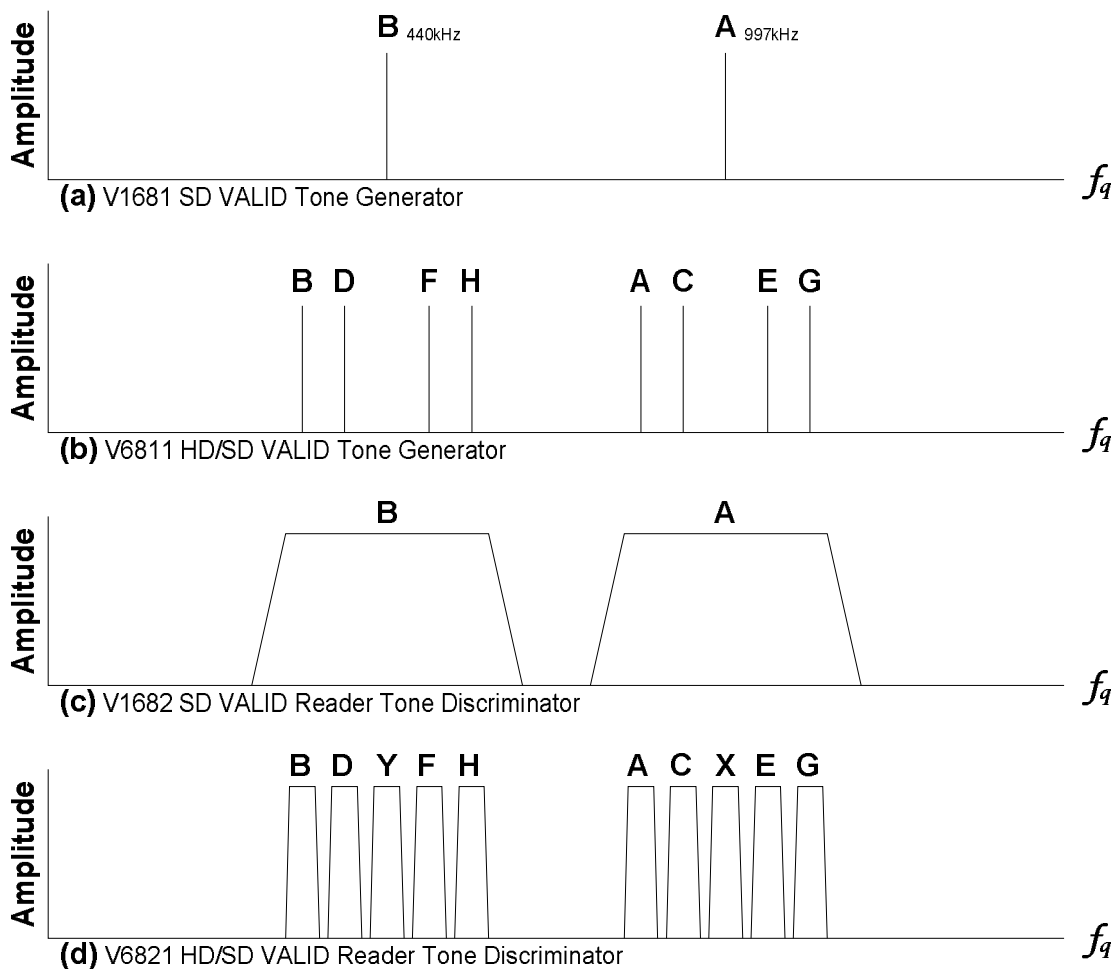

Figure 9 Frequency Spectra



4.4.6 Audio Idents (Internal)

In addition to the internally generated Glits tones the system (as long as it also has the V6812 fitted) can also generate audio identifications. These are pre-recorded announcements, stored as .wav files, that are downloaded from the CF card into the hardware. There can be separate files for each audio channel and they can be played out in time with the 4 second video sequence.

A particular feature of the Idents is that they can alternate with the Glits tones, so the audio can be used to both identify all the channels and to measure the timing. The tones and the idents are simultaneously available on the embedded, digital and analogue outputs.

There is a flexible relationship between the Glits tones and the idents and shows how they relate to one another. The audio O/P is usually selected to be solid tone or Glits tone but can also be a combination of Glits tone and the Ident. This is done under the AUDIO menu and when a selection of Glits and Ident IS MADE the choices are – **GL+ID 16**, **GL+ID 32**, **GL+ID 64** and **GL+ID 128**. This means that there will be a repeat rate of 16, 32 seconds etc. This repeat rate is always a multiple of the base 4 second cycle and is the total cycle time of the Glits plus the Ident.

traces A and B shows the timing relationship between the time Glits tone and the slot time for the Ident. Trace C shows how the Ident audio starts again on each cycle. If the audio is longer than the time slot allowed for it then it will be truncated, when it is shorter the remainder of the slot time is filled with silence, or optionally Glitz tone. Trace D shows the combined audio Glits tone with the Ident having silence between the end of the Ident to the end of the slot. Trace E shows the audio switching back to Glits tone immediately after the Ident in the **ID Auto** mode.

The Idents can be played once, as shown in trace C or continuously as shown in Trace F. This is set in the **IDENTS : ID Mode** menu which can be set to **ID Once**, **ID Loop**, or **ID Auto**. In all cases the Ident starts at the beginning of the cycle which may mean that the Ident gets cut off when playing in a loop as shown in Trace F. When a looping Ident is combined with the Glits there may be more truncation as shown in Trace G. When designing the Idents it is important to understand these timings and choose time slots accordingly.

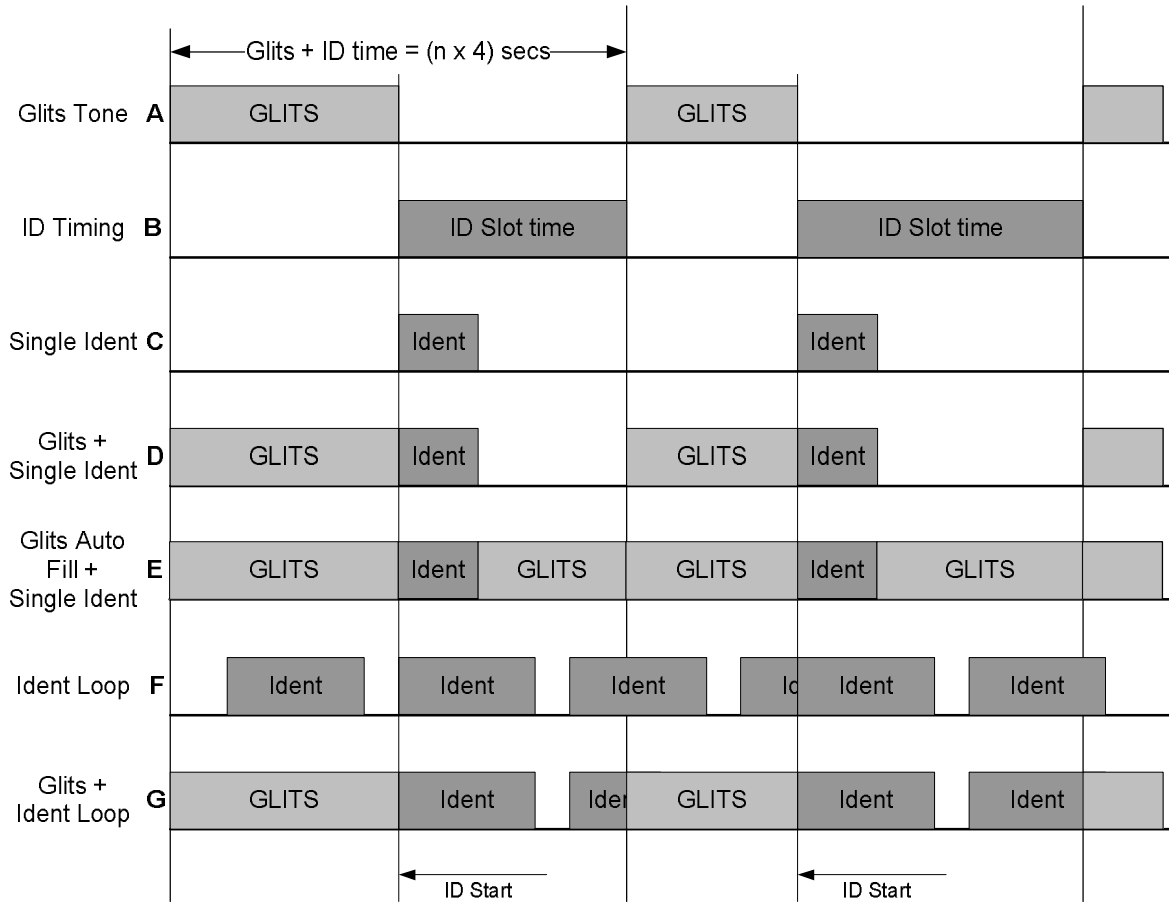

Figure 10 ID Slot Timing

As discussed in the Generator menu section the timings can be set in such a way as produce no Ident at all. For example the GL+ID time could be set to 16 secs while the ID Slot time is set to 32 secs which would allow 16 secs for the Glits after which it will reset to Glits again. There is no automatic warning for this condition. Therefore the GL+ID time should always be greater than ID Slot time.

4.4.7 Audio Idents (External)

As well as generating the Audio Idents internally from the Compact Flash card they can also be inserted from the external inputs, either analogue or digital. The placing of them is the same as the internally generated Idents. However, if the external Idents are not running continuously then they need to be timed into the gaps in the Glits tone. To help with this there is a pair of sync connectors on the rear panel; see rear panels in section **Error! Reference source not found..** On the generator external Idents are selected by setting ID Mode to ID Extn on the IDENTS menu.

The outgoing sync signal is timed to the Ident insertion and should be used to trigger the external Ident generator. The edges are always co-incident with the 4 second Black Flash sequence and the rising edge indicates the start of the audio Ident section. This is shown below in

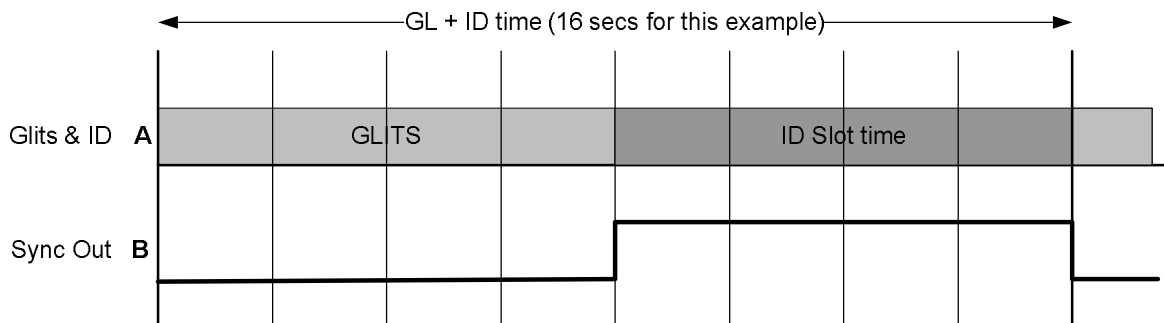

Figure 11 Sync signal timing

4.4.8 Audio Idents – Segments

In order to use the audio idents to identify up to the maximum of 8 channels per VALID Generator it is useful to be able to separate them in time. Even if two channels have an Ident saying “Channel X” “Channel Y” at the same time it may not be possible to distinguish them by listening to both. For this reason each Ident can be split up into a maximum of 17 segments. In a typical application with segments staggered in time segment 0 is the base segment and is played out on all channels at the start of the ID Slot time. The other segments are played out in sequence on the channel to which they belong with silence inserted between each part. The time allowed for each segment is the maximum length of all the segments. This is showed diagrammatically below in for 10 segments.

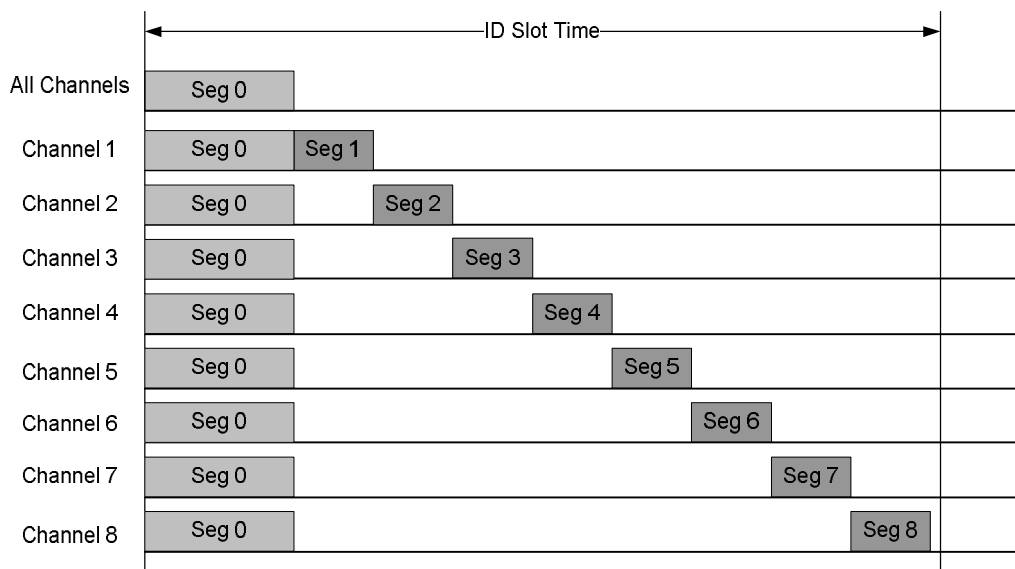

Figure 12 Audio Idents with staggered Segments

Interestingly this way of separating the actual idents is also useful when observing the outputs on PPM meters. The naturally progressing sequence is easily observed.

The CF card supplied with each V6812 audio part of the VALID Generator includes a default set of Idents with this feature and an application note on how to create .wav files for the Ident segments

The PC programme also supplied on the CF card with the Generator can be used to tie the wav files together with suitable segmentation. The supplied CF card already has a range of suitable wav file. The programme can also be used to define the video captions.

4.4.9 Audio Idents – .wav Files

The internal Ident system supports .wav files in mono, PCM, 16 bits and with sampling rates of 8kHz, 12kHz, 16kHz, 24kHz and 48kHz. The V6812 interpolates all Ident .wav files to the internal sampling rate of 48kHz for playout.

All internal Idents for the 8 channels being played out must have the same sampling rate selected from the list above. In other words channels A1 to D2 must have the same rate, and channels E1 to H2 must also have the same rate but it does not have to be the same as channels A1 to D2. This is because the two groups of eight are never played out at the same time.

The maximum length of each Ident that can be stored is shown in this table:

| Sample Rate | Max length per Channel |
|-------------|------------------------|
| 8 kHz | 48 s |
| 12 kHz | 32 s |
| 16 kHz | 24 s |
| 24 kHz | 16 s |
| 48 kHz | 8 s |

4.5 METER DISPLAYS

There are two types of meter display that can be overlaid onto the output of the Reader. One is the Delay Meter that shows the relative timing of the audio to the video for four audio channels in both a graphical, bar graph, form and text form. The other is a true real time PPM display of four audio channels. There is a choice of four types of PPM display – BBC, EBU types I and II and Nordic.

Normally the display shows one of each type of meter with the timing meters on the left and the PPM meters on the right. When doing this it is only possible to show the results for four of the channels and the operator must choose which four of the eight being monitored is to be displayed. Although the results from only four channels are being displayed all eight are still being measured and are available on the V6821 front panel and over the DART remote control system.

shows how the normal meter display looks.



Figure 13 Four Channel Delay Meter and PPM Display

With reference to it can be seen that there is more information than just the bars, particularly on the timing screen, than just the relative timing. The various parts of the display are described below:

Audio Source Bottom left hand corner indicates group number or AES, Analogue



Audio Inversion Down arrow on red background to the right of the detected audio channel

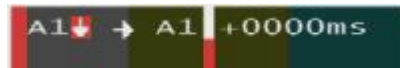

Down-mixed stereo pairs Letter 'M' on red background to the right of the detected audio channel



Channel Swaps Left panes indicate detected audio (left) in that channel (Right)



Audio delay Horizontal bars and numeric indication in right panes



Glits Tone Presence Latched symbol appears in the right panes when Glits tone is not present.

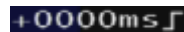

VALID video Presence Indicated in the bottom right-hand pane with VALID ü, or VALID X



The PPM display shows the following information:

Audio Not Present Channel letter at bottom of meter displayed on red background

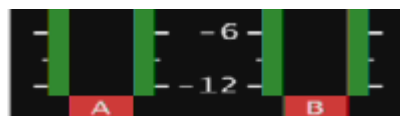

Audio level Vertical meter available in Nordic, BBC or EBU Scale & Type I, or II ballistics

If the display is set to show all eight timing displays it will look like with the first four channels on the left and the second four channels on the right. This display shows Audios A, B, C and D. If the last four channels were selected it would then show E, F, G and H.



Figure 14 Eight Channel Delays

If the display is set to show all eight PPM displays it will look like with the first four channels on the left and the second four channels on the right. This display shows Audios A, B, C and D. If the last four channels were selected it would then show E, F, G and H. There is only one setting for the PPM ballistics which applies to both displays.

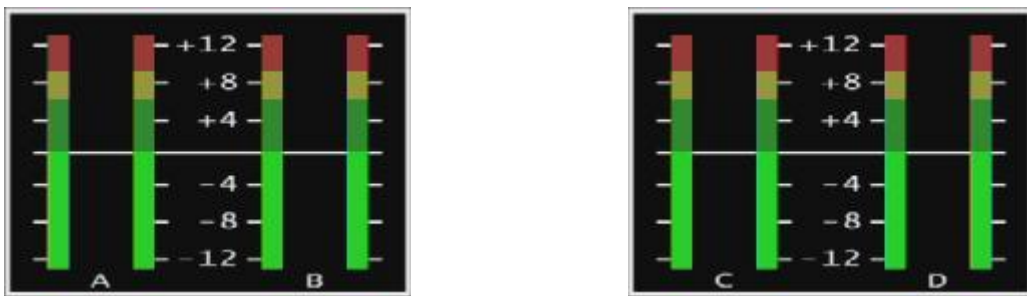

Figure 15 Eight Channel PPM Meters

5. BLOCK DIAGRAMS

5.1 V6821 VIDEO MODULE

The video processing on the V6821 has three purposes. Firstly it de-multiplexes any embedded audio and passes it through to the V6822 for analysis. Secondly it analyses the video to detect the presence and precise timing of the Black Flash which is also passed to the V6822 and thirdly it writes the delay and/or PPM meters onto the output video. The V6822 may not always use the de-embedded audio, but instead use external analogue or digital audio depending on the operator's selection.

The operator decides whether the on-screen displays show all delays, all PPMs or a combination of the two.

Only the V6822 can analyse the audio data to produce the PPM scales and these are passed back to the V6811 for display. If there is no V6822 then the V6821 on its own can only analyse the embedded audio for all the timing, routing and polarity conditions but not the PPM levels.

If the video input fails due to loss of the input or corruption the V6821 will output an internally generated black at the same video standard as the last input, and indicate 'SDI FAIL' on the video output.

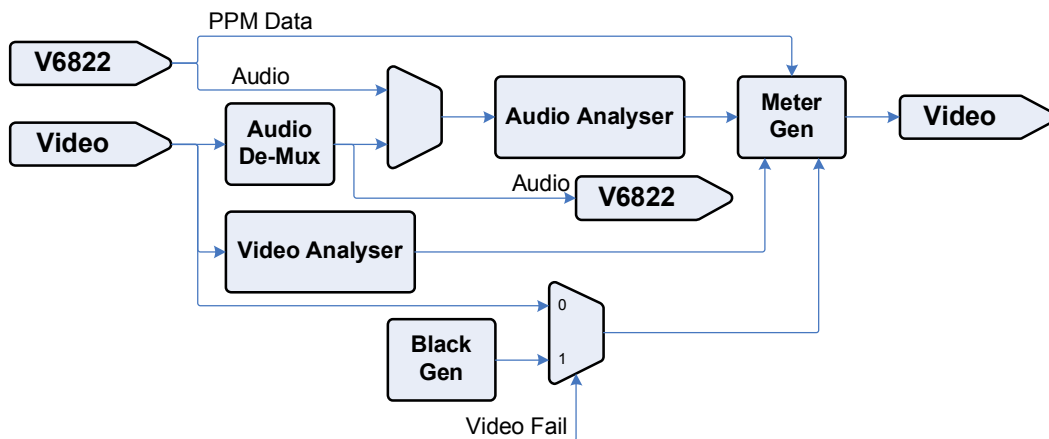

Figure 16 V6821 Block Diagram

5.2 V6822 AUDIO MODULE

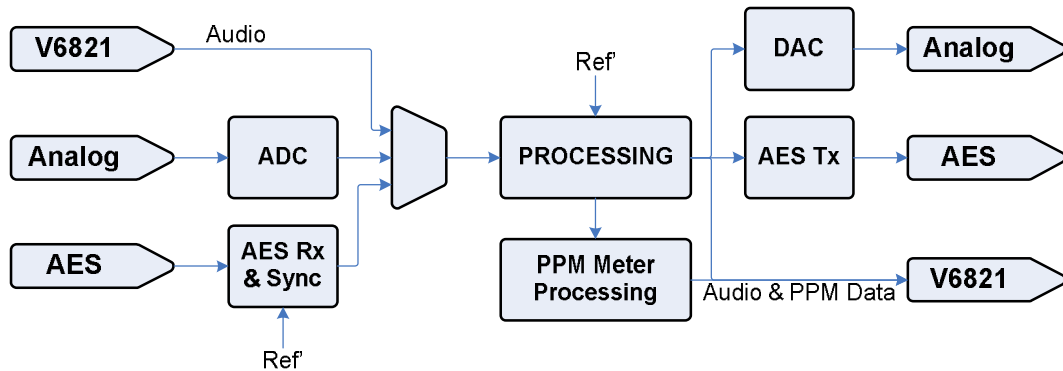

Figure 17 V6822 Block Diagram

On the diagram above, all audio routes are 8 channels (2 groups) wide.

The audio input is selected by the V6821 and can be embedded audio, external AES audio, or external analog audio, digitised by the on-board ADC. Input selection is made on the V6821 by means of the **Audio I/P** control in the **AUDIO** menu. After processing and delay path equalisation, the selected 8 channels of audio are returned to the V6821 for analysis. The selected audio signal in the V6822 is also processed into peak Programme Meter (PPM) meter values, and the resulting bar graph data is sent to the V6821 for on-screen display. Several scale options and ballistics options are available for the PPMs.

The eight selected input channels are also routed to the V6822 rear panel outputs as AES signals, and as analog signals after conversion by the on-board DAC. The analog and AES outputs are delay matched.

6. SYSTEM OPERATION

6.1 VALID MEASUREMENTS

The audio analysis and delay measurement results are available in the **MEASURE** menus of the V6821's front panel. The menus are organised into four sub-menus, one for each channel pair. In each sub-menu the status for each channel can be viewed in two different ways. Here is an example using the status of channel A1 and A2.

MEASURE : Ch A1&A2

A1+0000 \perp Audio to video delay measurement. The \perp symbol indicates the reading is current. A \lrcorner symbol would indicate the reading is a previous 'latched' value.
A2+0000 \perp current. A \lrcorner symbol would indicate the reading is a previous 'latched' value.
A1uA1 Audio channel detected. Channel on the left is the detected channel.
A2uA2 Channel on the right is the expected channel. A • indicates channel inversion.

Depending on the channels selection in **AUDIO : Channels** either channels A to D or E to H can be selected in the **MEASURE** menu. The results displayed are from the analysis of the audio on the currently selected audio input, **Embedded**, **AES**, or **Analog** in the **AUDIO : Aud I/P** menu.

6.2 VIDEO CONTROLS

6.2.1 Input Selection

The V6821 has two SDI inputs as detailed in section 2.2.1.1.

The input selection is done on the **VIDEO : Source** menu. Alternatively a GPI can be used to switch between inputs.

6.3 AUDIO CONTROLS

6.3.1 Audio Input Selection

The V6821 when used as a single module is an embedded only VALID reader. When the V6822 is used with the V6821 more audio interfaces become available. The V6822 has AES and analog audio inputs and outputs, but the available audio interfaces may be limited by the rear used. Audio input selection is done using the **AUDIO : Aud I/P** control with the available options of **Embedded**, **AES**, and **Audio**.

6.3.2 Audio Channel Selection

The analysis and processing engines in the V6821 and V6822 modules can only operate on 8 channels at a time. Similar to the VALID generator that can only generate 8 audio channels at a time the reader has a control to select between channels A to D and E to H, the **AUDIO : Channels** control.



6.3.3 MAL (Maximum Analog Level) Set Up

The VALID system works in both analog and digital domains, and therefore must be aware of the relationship between the two domains. The relationship is set up by specifying the maximum analog level in dBu that may be represented in the digital system (MAL). This parameter is adjustable from +12 to +24dBu, and may be adjusted with the **AUDIO : MAL** menu option.

The VALID reader detects the audio level of the input in the analog and digital domains, however because the relationship between them is variable, the digital level with respect to full scale will change as the MAL control is adjusted. In order for correct level measurements to be made, both reader and generator must have the same MAL setting, OR a compensating gain must be applied when going between regions with different digital level representations.

It should be noted that when the unit is only using analog I/O the MAL control still sets the internal headroom of the unit, so should still be set up correctly for the system.

6.4 METER CONTROLS

6.4.1 Meter Types

The V6821 can display 2 types of meter over the video output. A Delay Meter and a Level Meter. The Delay meter can show the audio to video delay measurement, channel error and warnings, and VALID video detection (black flash detection) for 4 channels. The Level meters show Peak Program Meters (PPMs) and channel presence for 4 channels. The two meters can be displayed in a number of different configurations using the **METERS : Meters** control:

| Left Side of Screen | Right Side of Screen | |
|---------------------|----------------------|-------------------------------------|
| Delay Meter | Delay Meter | Delays |
| Level Meter | Level Meter | Levels |
| Delay Meter | Level Meter | AB or EF / CD or GH Select required |
| channels | | |

6.4.2 Meter Enable

All on-screen meters can be turned **off** or **on** permanently using the **METERS : VALIDMtr** control. By default the control is set to **Auto**. This setting will automatically turn the meters on when a VALID black flash video timing signal is detected on the SDI input. If the signal is lost then the meters will be turned off.

6.4.3 Level Meter Options

The meter has a fixed range of -14 to +14 dBu, with three options for scale markings: **EBU**, **BBC** and **Nordic**, and two options for the ballistics of the meter: **Type I** and **Type II** as per IEC268-10. The options can be set in **METERS : Scale**, and **METERS : Ballistics**.

Type II ballistics have an integration time of 10ms and are commonly used in the UK and USA. **Type I** ballistics have an integration time of 5ms and are commonly used in Germany and the Nordic countries.

6.5 STATUS MENU

The status menu contains a collection of all the various card states for the V6821 and V6822 including information on inputs and includes version numbers of the various components that make up the modules.



6.5.1 V6821 States

The video standard of the selected video input, and the presence of both SDI inputs to the V6821 are reported.

I/P Std I/P 1 I/P 2

6.5.2 Audio Status

The V6821 monitors the selected SDI input for any audio groups that are present, this is reported back via the **Aud Grp** status. The channels present on the selected audio input are also indicated here **Aud Stat** in the form of **AxBxCxDx** or **ExFxGxHx**, where **x** indicates not present and **ü** is present. The AES audio presence is also reported back in the same way **AES Stat**.

6.5.3 Version Numbers

Each module comprises various items of software/hardware and they all have separate version numbers. These can be read on the following read only menus:

| | | | |
|---------------|-----------------|-----------------|-----------------------------------------|
| STATUS | IOModule | ID n | V6821 IO daughter module type |
| STATUS | V H8 S/W | XX.XX.XX | Main V6821 processor software version |
| STATUS | V FPGA | XX.XX | FPGA Code |
| STATUS | V CPLD | XX.XX | CPLD Code |
| STATUS | V PCB | XX.XX | The V6821 PCB revision, with Mod status |
| STATUS | V Boot | XX.XX.XX | Boot Loader |
| STATUS | A H8 S/W | XX.XX.XX | Main V6822 processor software version |
| STATUS | A DSP | XX.XX.XX | V6822 DSP software version |
| STATUS | A FPGA | XX.XX | V6822 FPGA Code version |
| STATUS | A CPLD | XX.XX | CPLD Code |
| STATUS | A PCB | XX.XX | V6822 base-module PCB version number |
| STATUS | A Boot | XX.XX.XX | Boot Loader |

6.6 ENGINEERING CONTROLS

6.6.1 EDH (SD operation only)

EDH is a method of embedding data within the ancillary data space that carries a measurement of the integrity of video and other data. By regenerating the equivalent measurement at the receiving end it is possible to check that the data has been received correctly.

HD signals always have the EDH data in form of checksums embedded, but for SD signals it is optional. On the V6821, the EDH on the output can be disabled on the **ENG' ING : O/P EDH** menu. Care must be taken if the new EDH generation is disabled and the old EDH is being passed through because it will probably not correctly represent the data. In this case the Ancillary Data really ought to be blanked.

6.6.2 Free-Run

There is a voltage controlled crystal oscillator, which is usually locked to the external video reference or to the input video. The clock from this oscillator is what clocks the SDI output video. This control provides direct control over the selection of the source of the oscillator's reference. When set on the oscillator will free-run at its mid frequency point. It is not recommended to change this control from its default off state.



6.6.3 Channel Hold Timing

The Delay measurement is displayed on the delay meters and the front panel as a current value or a latched previous value if a current delay measurement cannot be performed. This could be due to a loss or disturbance of the video or audio signals. The display of the delay measurement will remain in its latched form for a length of time before reverting to a hyphenated display (e.g. A1 ----) indicating that no measurement can be taken. The length of time the display remains in this latch state is configured in the **ENG' ING : ChnlHold** menu. Settings of **15 sec**, **1 minute**, **forever**, and **never** are available. **Never** meaning it will remain latched for ever, or until a delay measurement can be performed again, and **never** meaning it will immediately revert to a hyphenated display when delay measurements can no longer be performed.

The channel hold time is important when using audio Idents which may be alternating with the Glits tones. If you want the Reader to hold its results through the audio Idents then the Channel Hold Time must be longer than the ID Slot time on the Generator.

6.6.4 Display Sleep

Since, for the vast majority of its life, a module will operate behind the front panel of a rack frame, the display on the local front panel will not be visible so it will go to sleep after a certain time. This timeout delay can be changed on the **ENG' ING : Sleep** menu to be anything between 0 and 30 minutes; 0 minutes means that it will stay on indefinitely. The sleep timeout always counts from the last front panel button push. The default time is 5 minutes.

The panel can also be forced into its sleep mode by moving up a level from the Top Level menu, which displays the module type.

To get the display to come on again simply press one of the buttons and the menus will start again at the Top Level.

6.6.5 Display Brightness

The brightness of the front panel display can be adjusted on the **ENG' ING : LEDLevel** menu.

ENG' ING LEDLevel █ █ █ █

6.7 CONFIG CONTROLS

6.7.1 GPI control

GPI control is only available when the V6822 is used with the V6821 due the connections for the GPI being on the V6822. There are two external GPI inputs so that external hardware can simply select certain parameters. Connecting a GPI input to 0v activates the GPI, leaving it at +5V de-activates it. The status is shown in the STATUS menu as **GPI ↑** or **GPI ↓**, the former being active and the latter inactive (despite the fact that connecting it to 0v makes it active).

The pin numbers on the high density D-type and Screw Clamp connectors are in this table:

| Signal | HD Type | Screw Clamp |
|--------|---------|-------------|
| GPI 1 | Pin 24 | Pin 1 |
| GPI 2 | Pin 23 | Pin 2 |
| GND | Pin 10 | Pin 3 |
| +5V | Pin 22 | Pin 4 |

The screw clamp pins can be connected to the controlling relay as shown below in Figure 18.

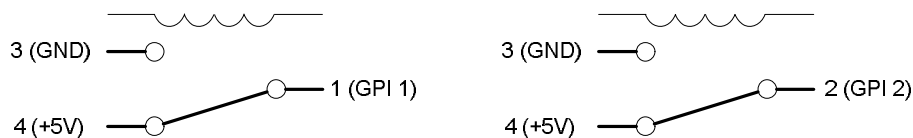

Figure 18 GPI Relay Connections

Various functions can be selected for each of the GPIs and there is no difference between them, other than that there is a priority GPI 1 (highest) and GPI 2 (lowest). Thus if the two GPI input controls conflict, GPI 1 will win. The GPI controls are set up in the three **CONFIG : GPI X** menus where **X** represents **1**, or **2**. The options available are :

| Display | Function |
|----------|-----------------------------------------------------|
| GPIx Off | GPI disabled (default) |
| SDI2 sel | Select 2 nd SDI input. |
| Chan E-H | Select channels E to H |
| MtrCD/GH | Display meters for 2 nd AES channel pair |

NOTE: There is no protection on these inputs. Damage can be caused to the V6822 if a voltage greater than +5 Volts is applied.



7. CALIBRATION

7.1 SET-UP

There is a separate Main Level Menu for Calibration and this should be used throughout. The first sub-level menu is Cal Mode, which can be used to turn calibration ON:

```

CALIB      Cal Mode  Cal Off
                   Cal On
  
```

The calibration mode must be turned ON before any parameter can be adjusted. The calibration mode will be turned OFF in one of four ways:

1. Manually on the **CALIB : Cal Mode** menu
2. By going up to the Top Level Menu
3. By re-powering the unit.
4. By letting the display timeout and go to sleep mode.

When the calibration mode is ON then the unit will automatically set up the required conditions in the unit as you enter each sub-menu. For example, if you go into the CntrFreq sub-menu, the unit will automatically go into free run. For obvious reasons this should not be done on a unit that is being used On Air.

7.2 FREE-RUN FREQUENCY

There is a voltage controlled crystal oscillator, which is usually locked to the external video reference or to the input video. However if there is no input or reference then it will free-run and this free running frequency should be set. The oscillator is not accurate enough to be used as a frequency reference, but nevertheless, should be set close to the ideal so that any succeeding SDI equipment will be able to lock to its output, and so that when in free run it will only drift slowly away from its starting reference.

To calibrate the frequency set the unit into Free Run by turning Cal Mode ON and selecting the CntrFreq sub-menu.

```

CALIB      Cal Mode  Cal On
  
```

Now compare the output picture movement on a monitor with an accurate external reference and adjust the frequency accordingly.

```

CALIB      CntrFreq          Range is -127 to +128
  
```

The setting is stored on the unit in non-volatile memory, and should not need regular adjustment.



7.3 ANALOG AUDIO I/O

The analog audio I/O of the V6822 audio module requires calibration to 'trim out' the small errors in the components. It is not the same as the MAL setting discussed in section 6.3.3. The module is calibrated at the factory and should not require recalibration under normal circumstances. However, should recalibration become necessary, it may be undertaken by the user provided the requisite equipment is available

The ADC and DAC sections are adjusted separately, and may be done in any order.

The calibration values relate directly to the V6822's sub-module and not the main board, and they are stored on the sub-module itself. This means that there is no need to re-calibrate a sub-module if it is moved from one board to another.

7.3.1 DAC

By turning Calibrate Mode ON and selecting one of the DAC sub-menus the unit will automatically generate a -18dBFS tone with an MOL of $+18\text{dBu}$.

To calibrate the frequency set the unit to generate Tone by turning Cal Mode ON and selecting one of the DAC sub-menus.

CALIB Cal Mode Cal On

Connect the outputs in turn to a high quality analog audio analyser and adjust each of the eight channels for 0dBu on:

CALIB DAC A1
CALIB DAC A2
CALIB DAC B1
CALIB DAC B2
CALIB DAC C1
CALIB DAC C2
CALIB DAC D1
CALIB DAC D2

7.3.2 ADC

Turn Calibrate Mode ON and select one of the ADC sub-menus.

CALIB Cal Mode Cal On

Connect the Analog inputs from a high quality dual domain audio generator to the inputs at $+16\text{dBu}$ and the AES outputs to an analyser. Set MAL to $+18\text{dBFS}$, and adjust the level on the AES outputs to -2dBFS .

CALIB ADC A1
CALIB ADC A2
CALIB ADC B1
CALIB ADC B2
CALIB ADC C1
CALIB ADC C2
CALIB ADC D1
CALIB ADC D2



8. CONTROLS

These tables show a complete list of all the parameters that can be controlled locally for the various configurations. Unless otherwise shown they can also be controlled over the DART remote control system. Not all menus are available at any one time, since they depend on module configurations and sometimes on the operating conditions. Entries marked with a ü in the V6822 column are only available when the V6821 is used with a V6822.

The tables also show the full range of the controls and their ranges and normalised value, if appropriate. The normalised value or setting is shown by the 'n'.

8.1 MEASURE MENU – MEASURE

| Main Menu | Sub Menu | Value | | Comment | V6822 |
|-----------|----------|----------|---|-----------------------------------|-------|
| MEASURE | Ch A1&A2 | A1 ---- | n | A1 Audio delay in milliseconds | |
| | | A2 ---- | | A2 Audio delay in milliseconds | |
| | | A1uA1 | | Channel detected on A1 | |
| | | A2uA2 | | Channel detected on A2 | |
| | Ch B1&B2 | As A1&A2 | | This menu will change | |
| | Ch C1&C2 | As A1&A2 | | Appropriately with the setting of | |
| | Ch D1&D2 | As A1&A2 | | AUDIO : Channels | |
| | Norm | ***** | | | |

8.2 VIDEO CONTROLS – VIDEO

| Main Menu | Sub Menu | Value | | Comment | V6822 |
|-----------|----------|-------|---|---------|-------|
| VIDEO | Source | I/P 1 | n | | |
| | | I/P 2 | | | |
| | Norm | ***** | | | |



8.3 AUDIO CONTROLS – AUDIO

| Main Menu | Sub Menu | Value | | Comment | V6822 |
|-----------|----------|----------------|---|----------------------------------|-------|
| AUDIO | Aud I/P | Embedded | n | Select audio source for analysis | |
| | | AES | | | |
| | | Analog | | | |
| | Channels | A-D/G1&2 | n | | |
| | | E-H/G3&4 | | | |
| | MAL | +18dB | n | Maximum Analog Level | |
| | | +12dB .. +24dB | | | |
| | Norm | ***** | | | |



8.4 METER CONTROLS – METERS

| Main Menu | Sub Menu | Value | | Comment | V6822 |
|-----------|----------|----------|---|------------------------------------|-------|
| METERS | Meters | Levels | | Display level meters for 8 chan's | |
| | | Delays | n | Display delay meters for 8 chan's | |
| | | CD or GH | | Display delay & level meters for 2 | |
| | | AB or EF | | channels | |
| | VALIDMtr | Auto | n | Automatically turn meters On/Off | |
| | | On | | Meters on permanently | |
| | | Off | | Meters off permanently | |
| | Scale | EBU | n | | |
| | | BBC | | | |
| | | Nordic | | | |
| | Bllstics | Type II | n | | |
| | | Type I | | | |



8.5 OPERATING CONDITIONS – STATUS

| Main Menu | Sub Menu | Value | Comment | V6822 |
|-----------|----------|--------------------------------------|--------------------------------------|-------|
| STATUS | Variant | V6821 | VALID Generator | |
| | V6822 | Attached | V6822 Audio I/O module attached | |
| | | None | | |
| | I/P Std | 720p59 | | |
| | | ↓ | | |
| | | Unknown | | |
| | | No Input | | |
| | I/P 1 | I/P 1 x | | |
| | | I/P 1 4 | | |
| | I/P 2 | I/P 2 x | | |
| | | I/P 2 4 | | |
| | Aud Stat | AxBxCxDx | X = not present, ü = present | |
| | Aud Grps | None | | |
| | | ↓ | | |
| | | 1 - 3 - | | |
| | | ↓ | | |
| | | 1 2 3 4 | | |
| | AES Stat | AxBxCxDx | X = not present, ü = present | ü |
| | Mem Size | 24MBytes | Must have 96Mbytes fitted | |
| | | 48Mbytes | | |
| | | 96Mbytes | | |
| | | None | | |
| | VModule | None | Processing module ident (0-7) | |
| | IOModule | | I/O module ident (0-3) | |
| | V H8 S/W | | V6821 Software version number | |
| | V FPGA | | V6821 FPGA Version number(BCD) | |
| | V CPLD | | V6821 CPLD Version Number(BCD) | |
| | V PCB | nn . nn | V6821 PCB Rev.HW Rev (nn = 00 .. 15) | |
| | V Boot | | V6821 Bootloader version number | |
| | A H8 S/W | | V6822 Software version number | |
| | A DSP | | V6822 DSP Software Version | |
| A FPGA | | V6822 FPGA Version number(BCD) | | |
| A CPLD | | V6822 CPLD Version Number(BCD) | | |
| A PCB | nn . nn | V6822 PCB Rev.HW Rev (nn = 00 .. 15) | | |
| A Boot | | V6822 Bootloader version number | | |



8.6 ENGINEERING – ENG’ING

| Main Menu | Sub Menu | Value | | Comment | V6822 |
|-----------|----------|----------|---|--------------------------------------------------|-------|
| ENG’ING | O/P EDH | EDH On | n | Only when O/P is SD | |
| | | EDH Off | | | |
| | Free-run | Free Off | n | | |
| | | Free On | | | |
| | ChnlHold | 15 sec | n | Hold latched delays for 15 second | |
| | | 1 minute | | Hold for 1 minute | |
| | | forever | | Hold forever | |
| | | never | | Do not hold at all | |
| | Sleep | 0 min | | Sleep mode off | |
| | | n min | | Time before going to sleep state – default 5 min | |
| | LEDLevel | | | Shown as bar graph | |
| | Norm | ***** | | | |

8.7 CALIBRATION – CALIB

| Main Menu | Sub Menu | Value | Comment | V6821 |
|-----------|----------|------------|------------------------------------------|-------|
| CALIB | Cal Mode | Cal Off | Changing calibration parameters disabled | |
| | | Cal On | Changing calibration parameters enabled | |
| | CntrFreq | -127->+128 | | |
| | ADC A1 | -127->+128 | | C |
| | ADC A2 | -127->+128 | | C |
| | ADC B1 | -127->+128 | | C |
| | ADC B2 | -127->+128 | | C |
| | ADC C1 | -127->+128 | | C |
| | ADC C2 | -127->+128 | | C |
| | ADC D1 | -127->+128 | | C |
| | ADC D2 | -127->+128 | | C |
| | DAC A1 | -127->+128 | | C |
| | DAC A2 | -127->+128 | | C |
| | DAC B1 | -127->+128 | | C |
| | DAC B2 | -127->+128 | | C |
| | DAC C1 | -127->+128 | | C |
| | DAC C2 | -127->+128 | | C |
| | DAC D1 | -127->+128 | | C |
| | DAC D2 | -127->+128 | | C |
| | Norm | ***** | | |



8.8 CONFIGURATION – CONFIG

| Main Menu | Sub Menu | Value | Comment | V6821 |
|-----------|----------|----------|-----------------------------------------------------|-------|
| CONFIG | GPI 1 | GPI1 Off | GPI disabled (default) | |
| | | SDI2 sel | Select 2 nd SDI input. | |
| | | Chan E-H | Select channels E to H | |
| | | MtrCD/GH | Display meters for 2 nd AES channel pair | |
| | GPI 2 | GPI2 Off | GPI disabled (default) | |
| | | SDI2 sel | Select 2 nd SDI input. | |
| | | Chan E-H | Select channels E to H | |
| | | MtrCD/GH | Display meters for 2 nd AES channel pair | |
| | Banner | On | Warning banner displayed in sleep state | |
| | | Off | | |
| | DefOpStd | 720p59 | For initial set up of black generator | |
| | Password | 0..99999 | For factory & maintenance options | |
| | SD/HD Op | Auto | Adapts to SD or HD I/P | |
| | | HD | Fixed for HD I/P | |
| | | SD | Fixed for SD I/P | |
| | V SetPCB | 0..15 | Maintenance password protected | |
| | V SetH/W | 0..15 | Maintenance password protected | |
| | A SetPCB | 0..15 | Maintenance password protected | |
| | A SetH/W | 0..15 | Maintenance password protected | |
| | TestMode | Off | | |
| | | On | TEST menu enabled | |
| | Factory | Mode Off | Maintenance password protected | |
| | | Mode On | | |
| Norm | ***** | | | |

9. TROUBLE SHOOTING GIUDE (FAQ)

This section is to be a help in solving some common difficulties. If there is no control from the front panel first check that the Rem/Local switch is set to *Local*.

- Q** My V6821 produces a black output with the text 'SDI FAIL' in the middle, a valid SDI video signal is connected to one of its inputs.
- A: 1. Check whether the Front Panel HD/SD LED is lit. This indicates that a signal is being received.
2. Check whether the Input selection is set correctly. VIDEO>Source = I/P 1 (or I/P 2)
- Q:** My V6821 produces no output, although a valid SDI video signal is connected to one of its inputs.
- A: Make sure that the mode of operation (SD/HD) matches with your Input Standard. Set to 'Auto' sensing if in doubt. CONFIG : SD/HD Op = Auto
- Q** There is no output from the external audio.
- A Check that you have correctly connected and selected either analogue or AES audio. On both the VALID Generator and Reader there are completely separate connections and they must be selected with either local or remote control.
- Q** The display never goes to sleep.
- A Check whether the Sleep delay has been set to 0 Mins, which means stay awake.

10. INITIALISATION & ERROR CODES

Every time a board goes through a power-on cycle, either by re-seating the board in the rack or by triggering the manual reset, a sequence of initialisation and self-test events is being carried out by the on-board microcontroller.

If anything goes wrong, an error message is shown on the front panel display and program execution halts. The following table shows the error messages and their meaning:

| | | |
|-----------------|----------|----------------------------------------------------------------------------|
| Flash upgrading | ERROR 01 | Flash erasing failed |
| | ERROR 02 | Flash programming failed |
| | ERROR 03 | Main program checksum error after programming |
| | ERROR 04 | Bootloader checksum error after programming |
| | ERROR 05 | No program loaded and no valid upgrade in Flash Stick |
| | ERROR 06 | Bootloader upgrade required but no valid bootloader upgrade in Flash Stick |
| FPGA Load | ERROR 07 | STATUS stayed low after CONFIG pulsed low |
| | ERROR 08 | DONE stayed high after CONFIG pulsed low |
| | ERROR 09 | STATUS went low during configuration |
| | ERROR 10 | DONE stayed low after configuration |
| Local EEPROM | ERROR 11 | Error writing to local EEPROM |
| | ERROR 12 | Error reading from EEPROM |
| | ERROR 13 | Initialising EEPROM to default data |
| | ERROR 14 | Initialising parameters to default data |
| Debug Port | ERROR 15 | Receive buffer overflow |
| | ERROR 16 | Receive overrun |
| | ERROR 17 | Receive framing error |
| | ERROR 18 | Receive parity error |

11. MENU TREE

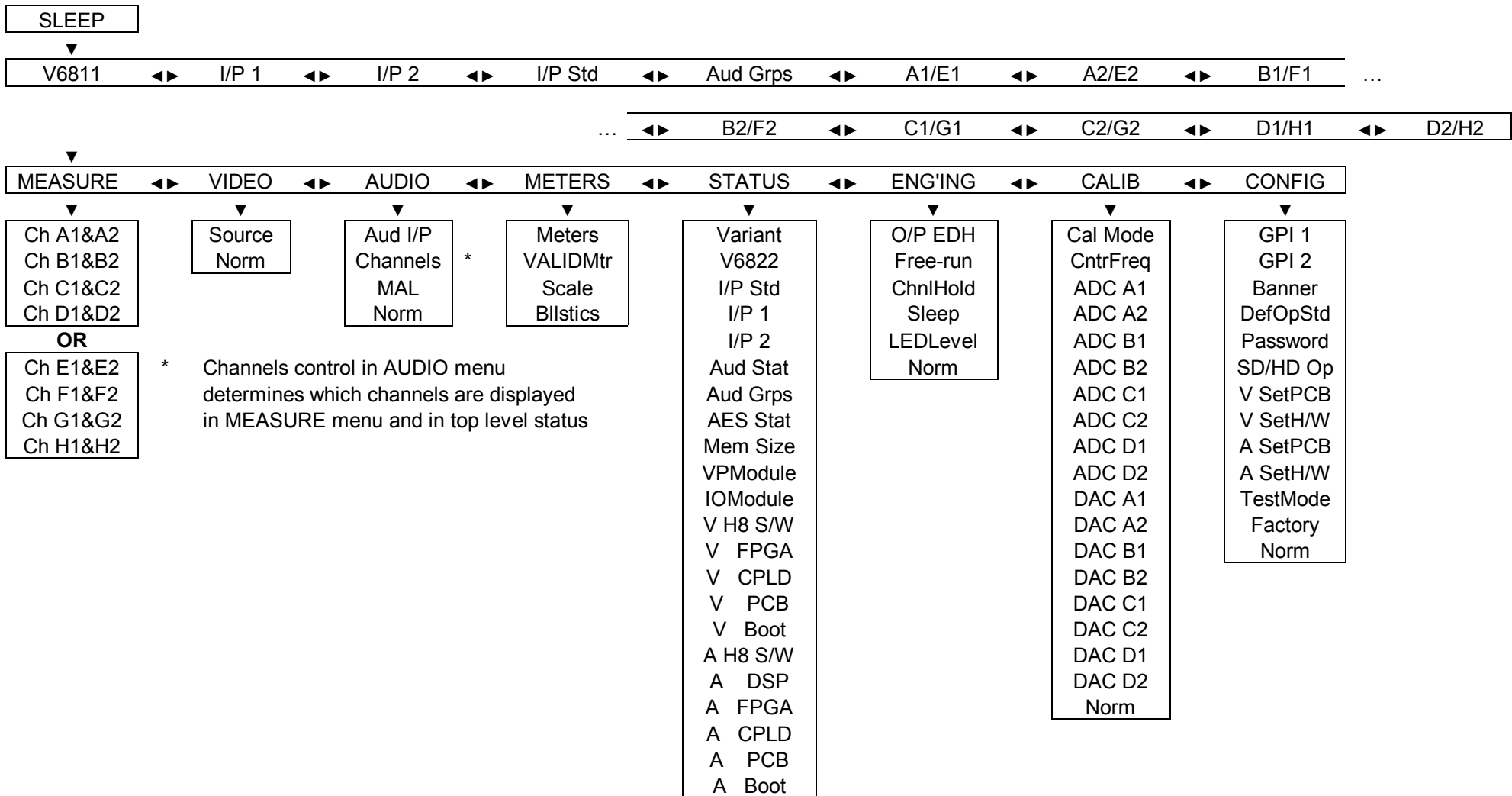

12. DOCUMENT REVISIONS

| Version | Release Date | Comments |
|---------|--------------|--------------------------------------------------------------|
| 1.0 | 23-05-07 | First Issue |
| 1.1 | 09-10-07 | Emended references to the maximum number Ident segment to 17 |
| | | Added Chapter 10 Initialisation and Error codes |
| | | Removed GPI not implemented yet comment |