

# Instruction Manual

071-8136-00  
OCTOBER 2001

**PROFILE XP PFR 500/E**  
FIBRE CHANNEL RAID STORAGE SYSTEM

**Copyright**

Copyright © 2001 Grass Valley Group Inc. Grass Valley, California.

Portions copyright © Ciprico, Inc. Reprinted with permission.

Printed in the United States of America. All rights reserved. This document may not be copied in whole or in part, or otherwise reproduced except as specifically permitted under U.S. copyright law, without the prior written consent of Grass Valley Group Inc., P.O. Box 1114, Crass Valley, California 95945 USA.

**Trademarks**

Grass Valley, GRASS VALLEY GROUP, Profile and Profile XP are either registered trademarks or trademarks of Grass Valley Group in the United States and/or other countries. Other trademarks used in this document are either registered trademarks or trademarks of the manufacturers or vendors of the associated products. Grass Valley Group products are covered by U.S. and foreign patents, issued and pending. Additional information regarding Grass Valley Group's trademarks and other proprietary rights may be found at [www.grassvalleygroup.com](http://www.grassvalleygroup.com).

Windows NT is a registered trademark of Microsoft.

**Disclaimer**

Product options and specifications subject to change without notice. The information in this manual is furnished for informational use only, is subject to change without notice, and should not be construed as a commitment by Grass Valley Group. Grass Valley Group assumes no responsibility or liability for any errors or inaccuracies that may appear in this publication.

**U.S. Government Restricted Rights Legend**

Use, duplication, or disclosure by the United States Government is subject to restrictions as set forth in subparagraph (c)(1)(ii) of the Rights in Technical Data and Computer Software clause at DFARS 252.277-7013 or in subparagraph c(1) and (2) of the Commercial Computer Software Restricted Rights clause at FAR 52.227-19, as applicable. Manufacturer is Grass Valley Group Inc., P.O. Box 59900, Nevada City, California 95959-7900 U.S.A.

**Revision Status**

Rev Date	Description
October 16, 2001	Initial release of the PFR500/E Fibre Channel RAID Storage Chassis Instruction Manual. 071-8136-00

**Notice**

THIS DOCUMENT HAS BEEN PREPARED FOR USE BY GRASS VALLEY GROUP INC. PERSONNEL, CUSTOMERS, AND PROSPECTIVE CUSTOMERS. THE INFORMATION CONTAINED HEREIN SHALL NOT BE REPRODUCED IN WHOLE OR IN PART WITHOUT PRIOR WRITTEN APPROVAL.

The right to make changes in specifications and other information contained in this document without prior notice is reserved, and the reader should in all cases consult GRASS VALLEY GROUP INC. to determine whether any such changes have been made.

NO REPRESENTATION OR OTHER AFFIRMATION OF FACT CONTAINED IN THIS DOCUMENT INCLUDING BUT NOT LIMITED TO STATEMENTS REGARDING CAPACITY, RESPONSE-TIME PERFORMANCE, SUITABILITY FOR USE OR PERFORMANCE OF PRODUCTS DESCRIBED HEREIN SHALL BE DEEMED TO BE A WARRANTY FOR ANY PURPOSE, OR GIVE RISE TO ANY LIABILITY OF DGC WHATSOEVER.

IN NO EVENT SHALL LIABILITY FOR ANY INCIDENTAL, INDIRECT, SPECIAL OR CONSEQUENTIAL DAMAGES WHATSOEVER (INCLUDING BUT NOT LIMITED TO LOST PROFITS) ARISE OUT OF THIS DOCUMENT OR THE INFORMATION CONTAINED IN IT, EVEN IF THE POSSIBILITY OF SUCH DAMAGES WAS KNOWN OR SHOULD HAVE BEEN KNOWN.

---

# Contents

	<b>Safety Summaries</b>	
	General Safety Summary .....	5
	Safety Terms and Symbols .....	6
	Service Safety Summary .....	6
	Certifications and Compliances .....	7
	<b>Preface</b>	
	About this manual .....	9
	Using the Profile XP documentation set .....	9
	Manual descriptions .....	10
	How this manual is organized .....	11
	Getting more information .....	12
	Grass Valley Group Web site .....	12
	Other on-line documentation .....	12
	Grass Valley Group Product Support .....	13
<b>Chapter 1</b>	<b>About the PFR 500/E</b>	
	PFR 500/E features .....	15
	Capacity and redundancy .....	16
	PFR 500/E components .....	16
	Chassis .....	18
	Midplane .....	18
	Disk modules .....	19
	Circuit board modules .....	20
	PFR 500E RAID Expansion Chassis circuit board modules .....	20
	PFR 500 RAID Storage Chassis circuit board modules .....	21
	Power supplies .....	22
	Fan modules .....	23
	Configurations .....	23
<b>Chapter 2</b>	<b>PFR 500/E Installation Information</b>	
	Installation requirements .....	25
	Site requirements .....	25
	Power .....	25
	Cooling .....	25
	Chassis address setting requirement .....	26
	Cabling requirements .....	27
	Binding disk modules into groups .....	27
	Installing a PFR 500/E in an equipment rack .....	28
	Unpacking the Chassis .....	28
	Installing the rack mounts .....	29
	Inserting the PFR 500/E chassis in the rack .....	31
	Installing the chassis with drive the support bracket .....	31
	Installing chassis without the drive support bracket .....	31
	PFR 500/E power-up and initialization .....	33
	Connecting electrical cables .....	33
	Powering-up the system .....	33
	PFR 500/E power-down .....	34
	Battery Backup recharge .....	34
<b>Chapter 3</b>	<b>Servicing the PFR 500/E</b>	
	Monitoring PFR 500/E status .....	36



Interpreting drive LED displays .....	36
Interpreting rear panel LEDs .....	37
Removing and installing disk drive modules .....	38
Removing a disk module .....	39
Installing disk module .....	40
Replacing the Loop Bypass Board (LBB) or RAID Controller .....	41
Removing the LBB or RAID Controller .....	41
Installing the LBB or RAID Controller .....	42
Replacing GBIC data ports .....	42
Replacing a power supply .....	43
Replacing the fan module .....	44
<b>Appendix A    Technical Specifications and                   Operating Limits</b>	
AC power requirements .....	45
Size and weight.....	45
Copper cable lengths .....	45
Environmental limits .....	46
<b>Index</b> .....	47

# Safety Summaries

---

## General Safety Summary

Review the following safety precautions to avoid injury and prevent damage to this product or any products connected to it.

*Only qualified personnel should perform service procedures.*

While using this product, you may need to access other parts of the system. Read the *General Safety summary* in other system manuals for warnings and cautions related to operating the system.

### Injury Precautions

- |  |  |
|--|--|
| <b>Use Correct Power Cord</b>                    | Power cords for this equipment, if provided, meet all North American electrical codes. Operation of this equipment at voltages exceeding 130 VAC requires power supply cords which comply with NEMA configurations. International power cords, if provided, have the approval of the country of use. |
| <b>Ground the Product</b>                        | This product is grounded through the grounding conductor of the power cord. To avoid electric shock, the grounding conductor must be connected to earth ground. Before making connections to the input or output terminals of the product, ensure that the product is properly grounded.             |
| <b>Do Not Operate Without Covers</b>             | To avoid electric shock or fire hazard, do not operate this product with covers or panels removed.   |
| <b>Do Not operate in Wet/Damp Conditions</b>     | To avoid electric shock, do not operate this product in wet or damp conditions.  |
| <b>Do Not Operate in an Explosive Atmosphere</b> | To avoid injury or fire hazard, do not operate this product in an explosive atmosphere.  |
| <b>Avoid Exposed Circuitry</b>                   | To avoid injury, remove jewelry such as rings, watches, and other metallic objects. Do not touch exposed connections and components when power is present.   |

### Product Damage Precautions

- |   |   |
|---|---|
| <b>Use Proper Power Source</b>                | Do not operate this product from a power source that applies more than the voltage specified.     |
| <b>Provide Proper Ventilation</b>             | To prevent product overheating, provide proper ventilation.                                       |
| <b>Do Not Operate With Suspected Failures</b> | If you suspect there is damage to this product, have it inspected by qualified service personnel. |



## Safety Terms and Symbols

### Terms in This Manual

These terms may appear in this manual:



**WARNING:** Warning statements identify conditions or practices that can result in personal injury or loss of life.



**CAUTION:** Caution statements identify conditions or practices that may result in damage to equipment or other property, or which may cause equipment crucial to your business environment to become temporarily non-operational.

### Terms on the Product

These terms may appear on the product:

DANGER indicates a personal injury hazard immediately accessible as one reads the marking.

WARNING indicates a personal injury hazard not immediately accessible as you read the marking.

CAUTION indicates a hazard to property including the product.

### Symbols on the Product

The following symbols may appear on the product:



DANGER high voltage



ATTENTION – refer to manual

## Service Safety Summary

### Do Not Service Alone

Do not perform internal service or adjustment of this product unless another person capable of rendering first aid and resuscitation is present.

### Disconnect Power

To avoid electric shock, disconnect the main power by means of the power cord or, if provided, the power switch.

### Use Care When Servicing With Power On

Dangerous voltages or currents may exist in this product. Disconnect power and remove battery (if applicable) before removing protective panels, soldering, or replacing components.

To avoid electric shock, do not touch exposed connections

## **Certifications and Compliances**

### **Canadian Certified Power Cords**

Canadian approval includes the products and power cords appropriate for use in the North America power network. All other power cords supplied are approved for the country of use.

### **FCC Emission Control**

This equipment has been tested and found to comply with the limits for a Class A digital device, pursuant to Part 15 of the FCC Rules. These limits are designed to provide reasonable protection against harmful interference when the equipment is operated in a commercial environment. This equipment generates, uses, and can radiate radio frequency energy and, if not installed and used in accordance with the instruction manual, may cause harmful interference to radio communications. Operation of this equipment in a residential area is likely to cause harmful interference in which case the user will be required to correct the interference at his own expense. Changes or modifications not expressly approved by Grass Valley Group can affect emission compliance and could void the user's authority to operate this equipment.

### **Canadian EMC Notice of Compliance**

This digital apparatus does not exceed the Class A limits for radio noise emissions from digital apparatus set out in the Radio Interference Regulations of the Canadian Department of Communications.

Le présent appareil numérique n'émet pas de bruits radioélectriques dépassant les limites applicables aux appareils numériques de la classe A prescrites dans le Règlement sur le brouillage radioélectrique édicté par le ministère des Communications du Canada.

### **EN55022 & EN55024 Class A Warning**

This product has been evaluated for Electromagnetic Compatibility under the EN 55022 and 55024 standards for Emissions and Immunity and meets the requirements for E4 environment.

This product complies with Class A (E4 environment). In a domestic environment this product may cause radio interference in which case the user may be required to take adequate measures.

### **FCC Emission Limits**

This device complies with Part 15 of the FCC rules. Operation is subject to the following two conditions: (1) this device may not cause harmful interference, and (2) this device must accept any interference received, including interference that may cause undesired operation.



## Safety Certification

This product has been evaluated and meets the following Safety Certification Standards:

Standard	Designed/tested for compliance with:
UL1950	Safety of Information Technology Equipment, including Electrical Business Equipment (Third edition).
IEC 950	Safety of Information Technology Equipment, including Electrical Business Equipment (Second edition, 1991).
CAN/CSA C22.2, No. 950-95	Safety of Information Technology Equipment, including Electrical Business Equipment.
EN60950	Safety of Information Technology Equipment, including Electrical Business Equipment 1992.

### ATTENTION

This product has been designed and certified to comply with certain regulatory requirements pertaining to Information Technology Equipment. This product has not been designed for use as a medical device. Without limitation of the foregoing, this product is not intended and has not been certified for use in a hospital or clinical environment to diagnose, treat, or monitor patients under medical supervision, and is not intended and has not been certified to make physical or electrical contact with patients, nor to transfer energy to or from patients and/or to detect such energy transfer to or from patients.



# Preface

## About this manual

The PFR 500/E Fibre Channel RAID Storage Chassis provides RAID protected storage for Profile XP Media Platforms and Grass Valley Group Media Area Networks. If you are responsible for installing and servicing the PFR 500/E in one of these systems, you should read this manual.

## Using the Profile XP documentation set

This manual is part of a full set of support documentation for the Profile XP Media Platform. The following figure illustrates how to use the Profile XP documentation depending on the task you are performing. For instructions on connecting and configuring the PFR 500 Fibre Channel RAID Storage Chassis, consult the Profile XP Installation Guide (local storage) or Media Area Network Instruction Manual depending on the system you are installing.

### Path for the Installer

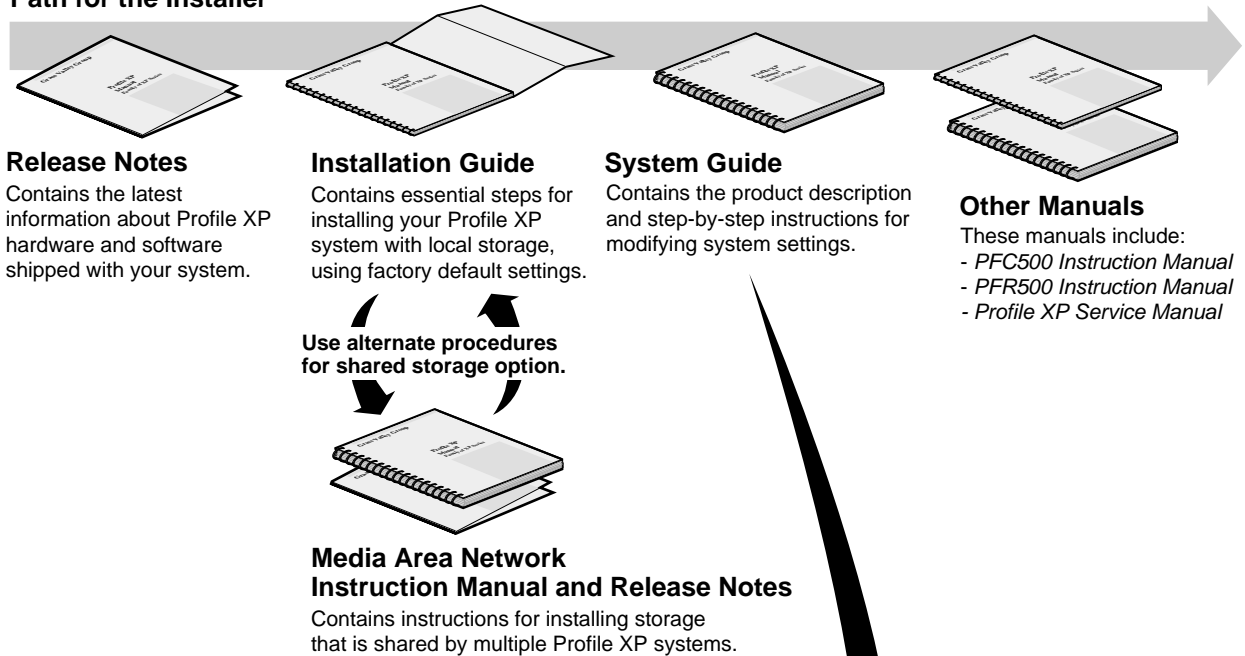

### Path for the Operator

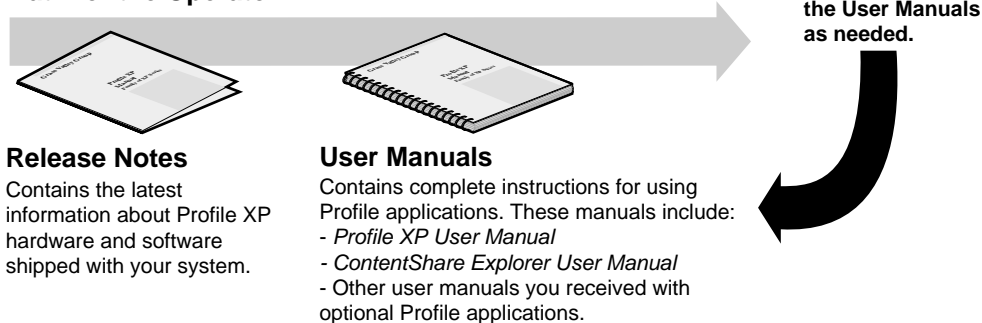

8118-10



## Manual descriptions

- **Installation Guide** (for each Profile XP Model) This guide provides step-by-step instructions for installing the Profile XP Media Platform using factory default settings for all record/play channels. Factory default settings are indicated within the guide. After installing the Profile XP system using this installation guide, you can refer to this *Profile XP System Guide* to customize system settings for your installation.
- **Profile XP System Guide** This guide provides all the information you need to go beyond factory default settings and customize your system's configuration to meet your site-specific needs. This guide also provides an overview of your Profile XP system, and provides all the specifications you need to integrate the Profile XP Media Platform into your operation.
- **Profile XP User Manual** Contains complete instructions for using Profile applications to operate the Profile XP Media Platform.
- **Profile XP Service Manual** Contains information for servicing the Profile XP Media Platform, and includes procedures for the following tasks:
  - Problem analysis using symptom, problem, solution tables.
  - Running diagnostics locally and remotely
  - Set up and operate NetCentral remote monitoring software.
  - Replacing field replaceable units.
- **Profile XP Release Notes** Contains the latest information about the Profile hardware and the software release shipped on your system. This information includes software specifications and requirements, feature changes from the previous releases, helpful system administrative information, and any known problems.
- **PFC 500/E Instruction Manual** Contains information for servicing the PFC 500 Fibre Channel RAID Storage Chassis (PFC 500/E) including step-by-step procedures for replacing field replaceable units.

## **How this manual is organized**

The following identifies and describes the chapters included in this manual:

### **Chapter 1 - About the PFR500/E**

Introduces the PFR500 Fibre Channel RAID Storage Chassis and the PFR500E RAID Expansion Chassis. You can read this chapter to get familiar with key features and components.

### **Chapter 2 - PFR500/E Installation Information**

Contains information needed for installation of a RAID Storage Chassis and RAID Expansion Chassis, including rack mounting information.

### **Chapter 3 - Servicing the PFR500/E**

Contains service information, such as FRU replacement procedures.

### **Appendix A - Technical Specifications and Operating Limits**

This appendix consists of electrical and environmental specifications.



## Getting more information

In addition to printed documents, Profile XP product information is available in electronic form. Use these as additional sources for information.

### Grass Valley Group Web site

Current versions of this manual and other Profile product documentation may be downloaded via the Product Documentation link on the Grass Valley Group home page.

### Other on-line documentation

Electronic versions of the following manuals are located on the system drive of your Profile XP Media Platform and on the Profile XP software CD-ROM.

- *Installation Guide* (for your model)
- *Profile XP System Guide*
- *Profile XP User Manual*
- *Profile XP Service*
- *PFR500/E Instruction Manual*
- *Profile XP Release Notes*

You can view these manuals using Adobe Acrobat Reader which is also pre-installed on your Profile XP system.

# Grass Valley Group Product Support

To get technical assistance, check on the status of problems, or report new problems, contact Grass Valley Product Support via e-mail, the Web, or by phone or fax.

## Web technical support

To access support information on the Web, visit the product support Web page on the Grass Valley Group Web site. You can download software or find solutions to problems by searching our Frequently Asked Questions (FAQ) database.

**World Wide Web:** <http://www.grassvalleygroup.com/support/>

**Technical Support E-mail Address:** [gvgtechsupport@grassvalleygroup.com](mailto:gvgtechsupport@grassvalleygroup.com).

## Phone support

Use the following information to contact product support by phone during business hours. Afterhours phone support is available for warranty and contract customers.

### USA and Americas (includes Latin America and Canada)

Telephone (800) 547-8949 (Toll Free)  
(530) 478-4148 (Direct Dial Toll Call)  
Fax (530) 478-3181

### Europe and UK

UK Regional Service Location  
Tel +44 1753 218 777  
Fax +44 1753 218 757

Italy  
Tel +39 72 901 428  
Fax +39 72 905 371

France  
Tel +33 145 297 300  
Fax +33 145 297 302

Germany  
Tel +49 221 1791 234  
Fax +49 221 1791 235

### Asia Pacific

Australia  
Tel (612) 8877 6800  
Fax (612) 8877 6825

India  
Tel (91) 11 373 0544  
Fax (91) 11 373 0543

China  
Tel (86) 10 6235 1185  
Fax (86)10 6235 1190

Japan  
Tel (813) 5484 6869  
Fax (813) 5484 3775

Hong Kong  
Tel (852)-2531-3000  
Fax (852)-2802-2996

South East Asia  
Tel (65) 7328 729  
Fax (65)7327 649

## Authorized support representative

A local authorized support representative may be available in your country. To locate the support representative for your country, visit the product support Web page on the Grass Valley Group Web site.

## Profile Users Group

You can connect with other Profile XP Media Platform users to ask questions or share advice, tips, and hints. Send e-mail to [profile-users@grassvalleygroup.com](mailto:profile-users@grassvalleygroup.com) to join the community and benefit from the experience of others.



---

## About the PFR500/E

This chapter introduces the PFR 500 Fibre Channel RAID Storage Chassis. Topics include:

- PFR 500/E features
- PFR 500/E components
- Configurations

### PFR 500/E features

The PFR 500 Fibre Channel RAID Storage Chassis is a high performance, high availability mass storage system. High-bandwidth storage is made possible using Fibre Channel Arbitrated Loop (FC-AL) technology. The PFR 500's modular, scalable design provides additional disk storage as your needs increase.

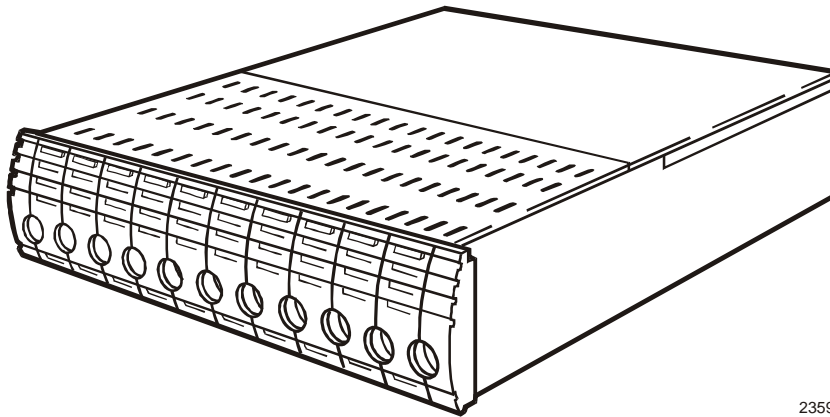

2359

Feature highlights:

- Ten drives in a 3U vertical rack space
- No single point of failure
- All active components are hot-serviceable
- Scalable expansion using PFR 500E RAID Expansion Chassis
- Optional dual RAID controllers provide Fibre Channel failover
- Copper Fibre Channel interface (GBIC)

The PFR 500 utilizes dual FC-AL technology, allowing two loop configurations within a single chassis. Port-Bypass Circuits have been added to maintain loop integrity during failures without user intervention. Each loop and associated Port



Bypass Circuits along with all other active components are on redundant, separate hot swappable modules. This improves serviceability and increases fault tolerance by eliminating any single point of failure. With two RAID Controllers, the two loops within a single standard chassis are configured as a single loop with a backup loop in standby mode.

## Capacity and redundancy

The PFR 500 contains five or ten half-height 3.5" Fibre Channel Arbitrated Loop (FC-AL) disk drives. The chassis also supports one or two hardware RAID Controllers in one 3U high rack-mountable chassis. The PFR500 currently uses 36GB, 73GB or 180GB drive capacities. With ten drives, one chassis holds up to 360GB, 730GB or 1.8TB depending on the disk drive option.

The PFR 500E RAID Expansion Chassis provides additional storage capacity. It is an identical chassis with two Loop Bypass Board installed. Up to nine PFR 500E RAID Expansion Chassis can be connected to a single PFR 500 comprising a single disk-array storage system with a total of 100 drives and 3.6TB, 7.3TB or 18TB of storage depending on the disk drive option. The built-in chassis daisy-chaining capabilities provide for cost effective storage expansion as requirements grow.

Throughout this manual, the term PFR 500/E is used to refer to either the PFR500 or the PFR500E interchangeably.

## PFR 500/E components

The PFR 500/E components are:

- The chassis with passive midplane board
- One or two RAID controllers (PFR500 only)
- One or two Loop Bypass Boards
- As many as ten Fibre Channel disk drives per chassis
- Two power supplies
- Two fan modules

The RAID Controllers, Loop Bypass Boards, disk drives, power supplies, and fan modules are hot-swappable field replaceable units (FRUs), which means you can add or replace them while the PFR 500/E is powered up.

Optional modules for the PFR 500/E are:

- Second RAID Controller Module (PFR500 only). Allows for continued access to the PFR500 if the primary RAID Controller fails. Adding a second RAID Controller to the same chassis is not intended to increase performance, but rather to add redundancy. Refer to your Profile XP PVS Series Installation Guide for detailed connection and configuration instructions.

The following figure shows the PFR 500/E components. Details on each component follow the figure.



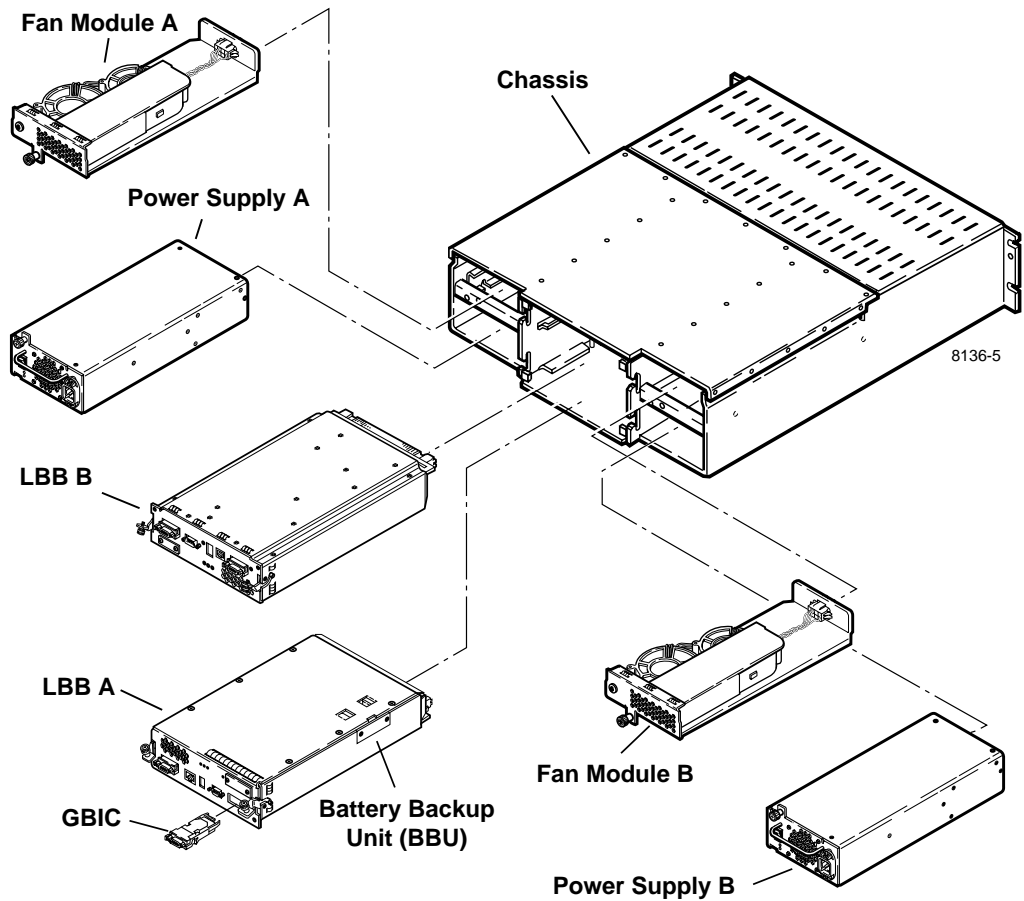

**NOTE:** Every PFR500/E RAID controller includes a backup battery so that if electrical power is lost, data stored in cache memory will be saved. Data store cache is not used in the PFR500/E, so the Battery Backup module is not used, even though it ships as part of the LBB module.



## Chassis

The chassis is a sheet-metal housing which contains a passive midplane and chassis slots for the RAID Controllers, or Loop Bypass Boards, disk drives, power supplies, and the fan modules.

Each chassis includes a *chassis address switch* on the midplane board that must be set to a unique address 0 through 9 during installation. Refer to [“Chassis address setting requirement” on page 26](#) for information on changing the chassis address.

The following diagram shows how disk drive modules are identified based on the chassis address and physical location. The chassis with an address set to 0 contains drives from 0 to 9; the chassis with an address set to 1 contains drives from 10 to 19; and so forth.

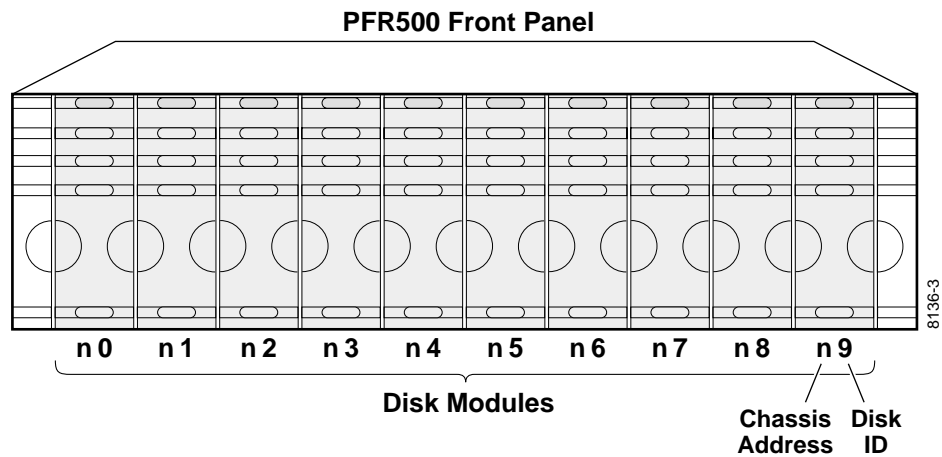

## Midplane

The midplane distributes power and signals to all the chassis components. All FRUs plug directly into midplane connectors. The midplane includes a chassis address switch that must be set during installation. Refer to [“Chassis address setting requirement” on page 26](#) for information on setting the chassis address.

## Disk modules

Each disk module consists of a Fibre Channel disk drive in a carrier assembly. If a disk drive fails, and needs replacing, you can do so while the PFR500/E is powered up.

The disk drives are 3.5-inch FC-AL drives that conform to the Fibre Channel Arbitrated Loop (FC-AL) standards and support dual-port FC-AL interconnects through the two RAID controllers and their cabling.



**CAUTION:** *Once the PFR500/E is installed and configured, the disk modules become slot dependent. Moving disk modules between physical slots will result in loss of data and the need to reconfigure the system.*

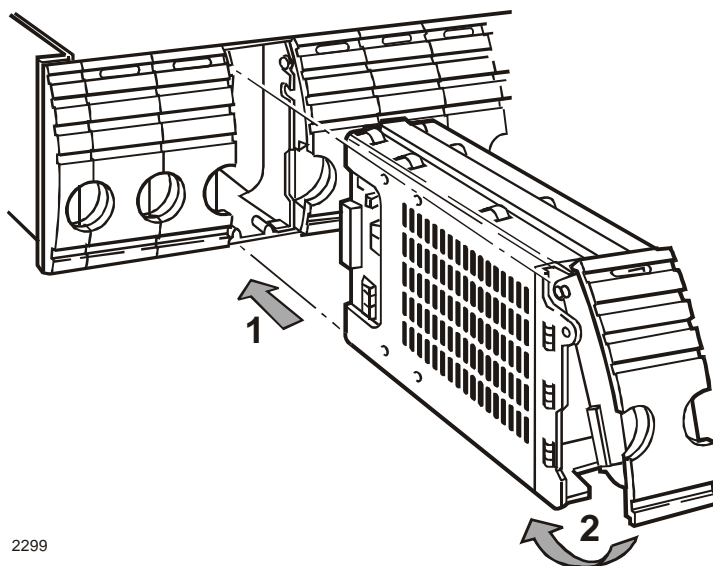

2299



## Circuit board modules

There are two circuit board modules used: the Loop Bypass Board module (LBB) and the RAID Controller module. The LBB module contains one Loop Bypass Board which provides an internal Fibre Channel loop for the disk drive modules installed in the chassis. The RAID Controller module also contains a Loop Bypass Board plus a RAID Controller board used to manage the disk drives and provide a Fibre Channel interface to the Profile system.

### PFR500E RAID Expansion Chassis circuit board modules

PFR500E RAID Expansion Chassis always has two LBB modules installed as shown in the following figure. This provides two internal Fibre Channel loops for the disk drive modules. At power-up, odd numbered disk drives are supported by the LBB in the 'A' slot, while even numbered disk drives are supported by the LBB in the 'B' slot. In the event of an LBB module failure, the faulty loop is bypassed and all disk drives failover to the remaining LBB module. The LBBs are clearly labeled "A" or "B" on the rear panel of the canister.

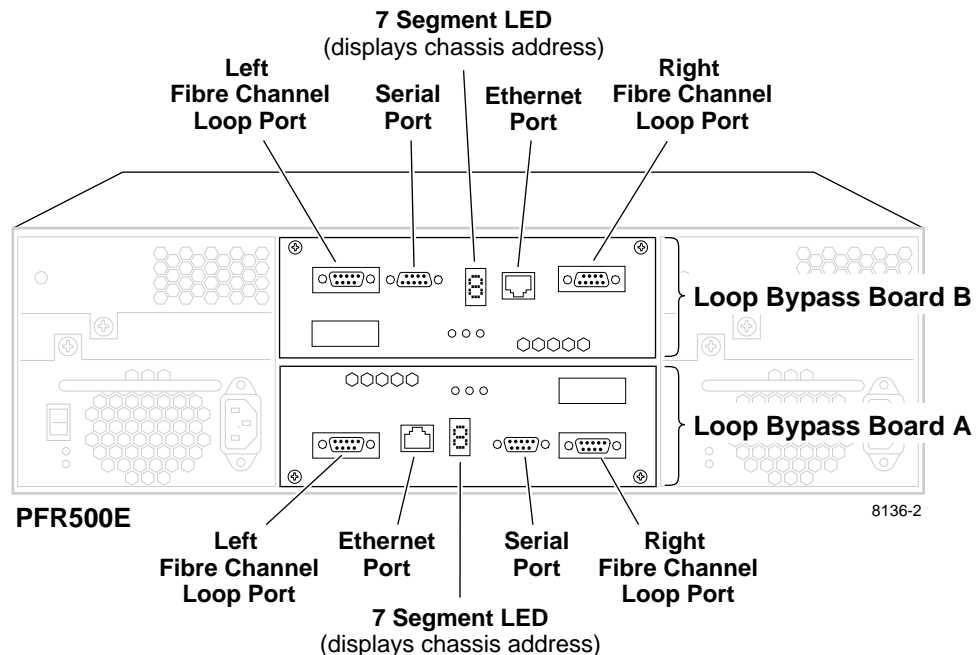

The LBB in the PFR500E has two Fibre Channel ports: the Left and Right Fibre Channel Loop Ports. Copper GBICs (Gigabit Interface Converter) are used in these ports to connect Fibre Channel cabling to a PFR500 or PFR500E. This extends the Fibre Channel loop of the corresponding PFR500/E chassis. There is a port status LED for each Fibre Channel port. Refer to [“Monitoring PFR500/E status” on page 36](#).

**Installing a GBIC  
(Gigabit Interface Converter)**

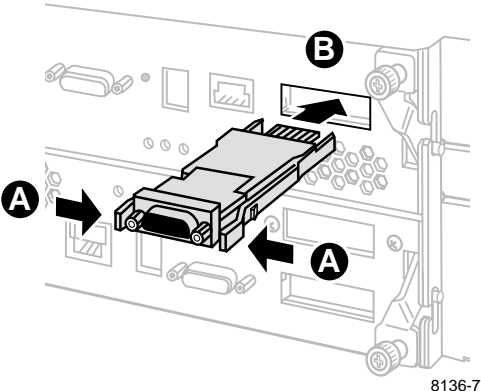

An RJ-type connector is provided for Ethernet network connection. A DB-9 serial communications connector is provided for serial communications with a console program. Neither of these connectors are used in Grass Valley Group Profile systems.

**PFR 500 RAID Storage Chassis circuit board modules**

A PFR 500 includes one or two RAID Controller modules. Two RAID Controller modules are installed when the redundant Fibre Channel option is installed. This provides redundant Fiber Channel interface ports to the Profile system or Fibre Channel switch fabric. The following figure shows a PFR 500 Fibre Channel RAID Storage Chassis with the two RAID Controller Modules installed. The RAID Controllers are clearly labeled “A” or “B” on the rear panel of the canister.

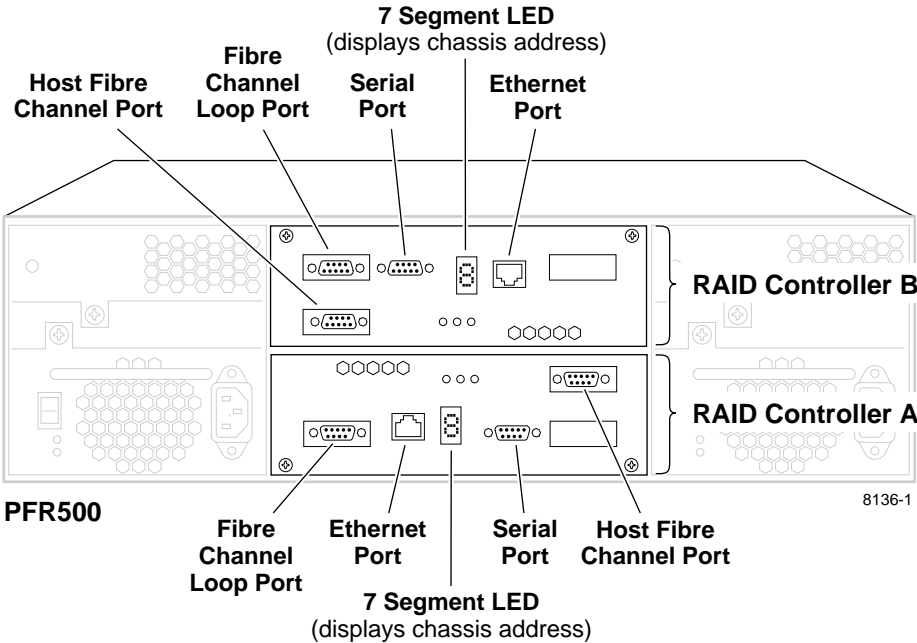



When the redundant Fiber Channel option is not installed, only one RAID Controller is installed along with one LBB module as shown in the following figure. The LBB module and the LBB contained in the RAID Controller module provide the two LBBs required in the PFR500 Fibre Channel RAID Storage Chassis. The LBB and RAID Controller modules are clearly labeled on the rear panel of each canister.

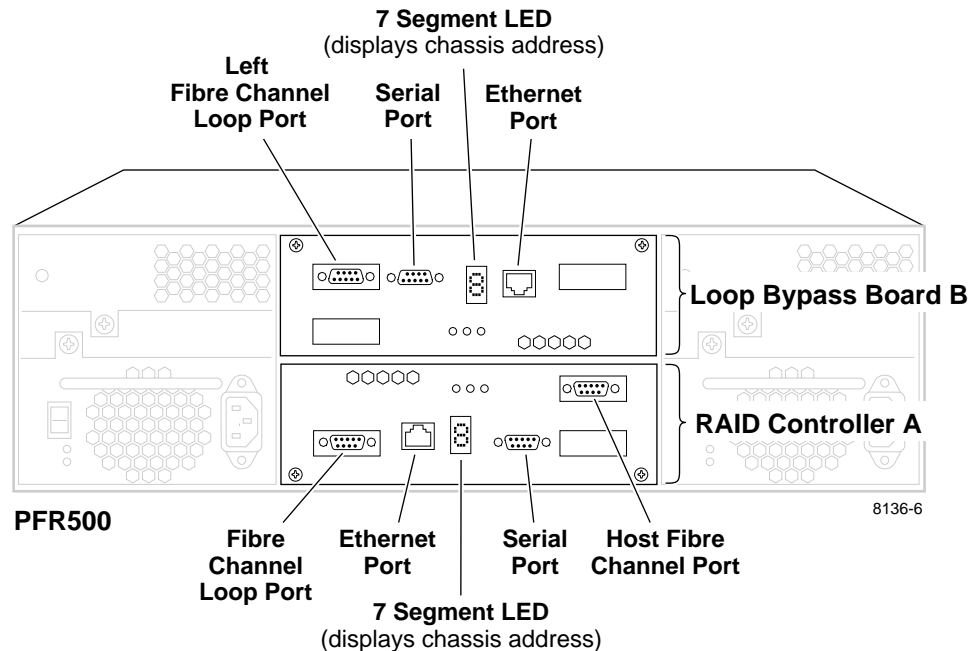

The RAID Controller is equipped with a passive 9-pin copper GBIC installed as the Fibre Channel host port. The RAID Controller also has a Fibre Channel loop expansion port which extends the internal Fibre Channel Loop to the corresponding Loop Bypass Board in a PFR500E Expansion Chassis.

An RJ-type connector is provided for Ethernet network connection. A DB-9 serial communications connector is provided for serial communications with a console program. Neither of these connectors are used in Grass Valley Group storage systems.

The RAID Controller includes rear panel Fibre Channel loop port status LEDs and other activity LEDs. Refer to [“Monitoring PFR500/E status” on page 36](#).

## Power supplies

There are two auto-ranging power supplies, each with its own power cord and standby switch. Each supply supports a fully configured PFR500 and shares load currents with the other supply, if it is present. The power supplies are designed so as to protect the disk drives if you install them while the PFR500/E is powered up. A disk with power-related faults will not adversely affect the operation of any other disk.

Each power supply has status LEDs visible from the rear panel. The status LEDs are described in the [“Monitoring PFR500/E status” on page 36](#).

A retaining screw secures the power supply in place. You can add or remove one power supply in the PFR500/E while the PFR500/E is powered up.

## Fan modules

There are two fan modules used to cool the components installed in the PFR500/E chassis. The fan modules connect to the midplane board for power.

One status LED on the rear panel of the fan module indicates status. The status LED is described in the “Monitoring PFR500 status” section of Chapter 3.

A retaining screw on the fan module holds the module in place.

**NOTE:** *If power is connected, fans run at low speed even with the power supply switches in standby position.*

## Configurations

The PFR500 RAID Storage Chassis minimum and maximum configurations are as follows.

PFR500 Configuration	RAID Controller	Loop Bypass Board	Power Supplies/Fan modules	Disk Modules
minimum	1	1	2	5
maximum	2	0	2	10

The maximum configuration provides the most redundancy, and therefore the highest degree of system availability.

The PFR500E RAID Expansion Chassis minimum and maximum configurations are as follows.

PFR500E Configuration	Loop Bypass Board	Power Supplies/Fan modules	Disk Modules
minimum	2	2	5
maximum	2	2	10

**IMPORTANT:** *Grass Valley Group does not support mixing disk drives of differing capacities in any RAID chassis. All disk drives in any RAID chassis must be of the same capacity. For example, if a PFR500 and a PFR500E are connected, all the disk drives in both the PFR500 and the PFR500E must be of the same capacity.*





## **PFR500/E Installation Information**

---

This chapter describes information you'll need to install the PFR500 Fibre Channel RAID Storage Chassis (PFR500/E). Major topics are:

- [Installation requirements](#)
- [Installing a PFR500/E in an equipment rack](#)
- [PFR500/E power-up and initialization](#)
- [PFR500/E power-down](#)

### **Installation requirements**

This section describes the following requirements:

- [“Site requirements” on page 25](#)
- [“Chassis address setting requirement” on page 26](#)
- [“Cabling requirements” on page 27](#)
- [“Binding disk modules into groups” on page 27](#)

### **Site requirements**

For proper PFR500/E operation, the installation site must conform to certain environmental specifications. These are detailed below and in [Appendix A, “Technical Specifications and Operating Limits”](#).

#### **Power**

Refer to [“AC power requirements” on page 45](#) for AC power requirements. The values indicate either the values for the power cord of a PFR500/E with a single power supply, or the total values shared by the line cords of two power supplies in the same PFR500/E, with the division between the power cords and supplies at the current sharing ratio. If one of the two power supplies fails, the remaining supply and cord must support the full load. You must use a rack mount cabinet with ac power distribution, and have main branch ac distribution that can handle these values for the number of PFR500s and PFR500Es that you will interconnect.

#### **Cooling**

Make sure your site has air conditioning of the correct size and placement to maintain the specified ambient temperature range. The air conditioning must be able to handle the requirements of the PFR500s and any connected PFR500Es as indicated under [“Environmental limits” on page 46](#).



## Chassis address setting requirement

Each PFR500/E storage chassis has a chassis address switch that must be set to a unique chassis address. Valid chassis addresses are 0-9 with 0 being reserved for the PFR500 RAID Chassis. All chassis are shipped with the chassis address set to 0.

The chassis address switch is located inside the chassis on the midplane board. The following figures show how to gain access to the switch by removing the board canisters.

**CAUTION:** Refer to the PVS Series Installation Guide you received with your Profile XP storage system or the Media Area Network Instruction Manual for step-by-step instructions for setting the chassis address.

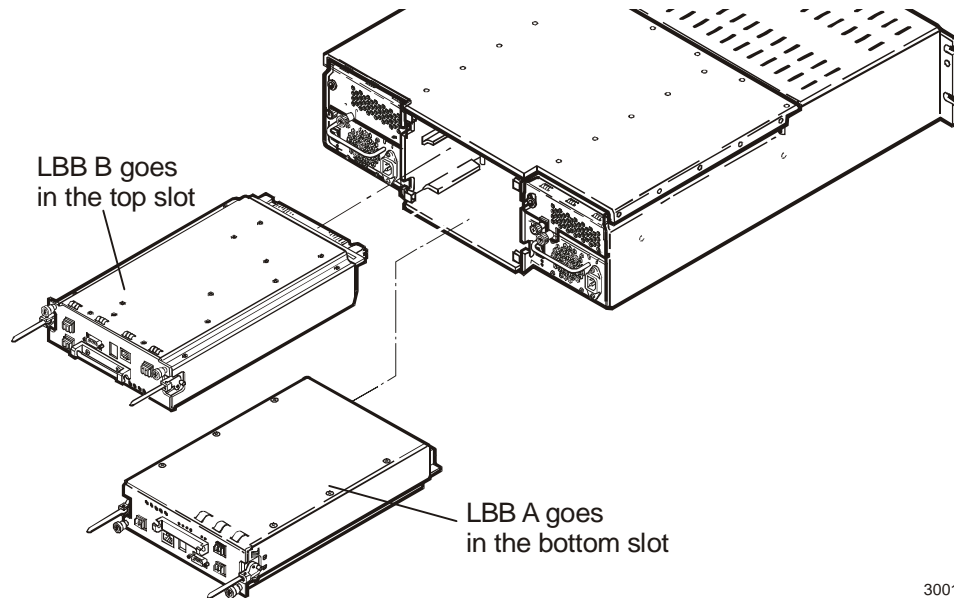

The midplane is at the back of the slot that held the LBB canisters. On the midplane is a small, white rotary switch.

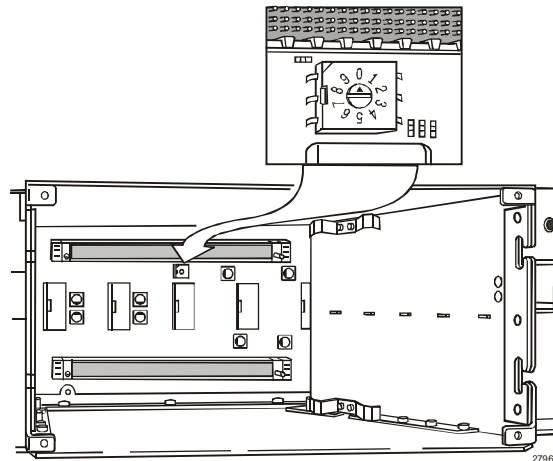

After the chassis addresses have been set and the chassis powered-up, the chassis address is displayed on the 7-segment display LED as shown.

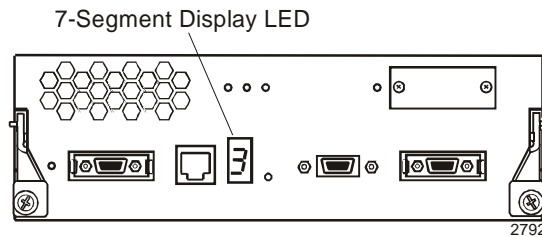

## Cabling requirements

It is recommended that you use the copper Fibre Channel cables shipped with your PFR500 when making connections.

Any copper cables you use must meet the appropriate standards for 1-Gbit FC-AL loops. Such cables are fully shielded, twin-axial, full-duplex cables with DB-9 connectors. Cables greater than 10 meters must be equalized; cables equal to or less than 10 meters do not need to be equalized. Do not use copper cables longer than 15 meters for any Fibre Channel connection in a Profile system.

PFR 500 and PFR 500E interconnections should maintain LBB consistency. That is, one FC loop should connect the PFR500's RAID Controller A and each PFR500E's LBB A. The other FC loop should connect the PFR500/E's RAID Controller B and each PFR500E's LBB B.

Do not leave an unused (that is, dangling) cable connected to a Fibre Channel port because it may cause excess noise on the loop.

## Binding disk modules into groups

After cabling a PFR500 and any PFR500Es, you must bind disk modules into LUNs using a Disk Utility provided by Grass Valley Group. Refer to the appropriate manual for information on using the Disk Utility to bind drives.

Type of PFR500/E installation	Manual to use for binding procedures
Part of a Media Area Network	<i>Media Area Network Instruction Manual</i>
Connected directly to a Profile XP Media Platform as local storage	<i>PVS Installation Guide</i> (for your Profile XP model) or the <i>Profile XP System Guide</i>



## Installing a PFR500/E in an equipment rack

Use the information in this section to unpack the PFR500/E chassis and mount in an equipment rack.

Procedures include:

- [Unpacking the Chassis](#)
- [Installing the rack mounts](#)
- [Installing the chassis with drive the support bracket](#)
- [Installing chassis without the drive support bracket](#)

### Unpacking the Chassis

Unpack the PFR500/E chassis, cables, and installation kit.



**WARNING:** A PFR500/E chassis is heavy. Two people should lift and move it.

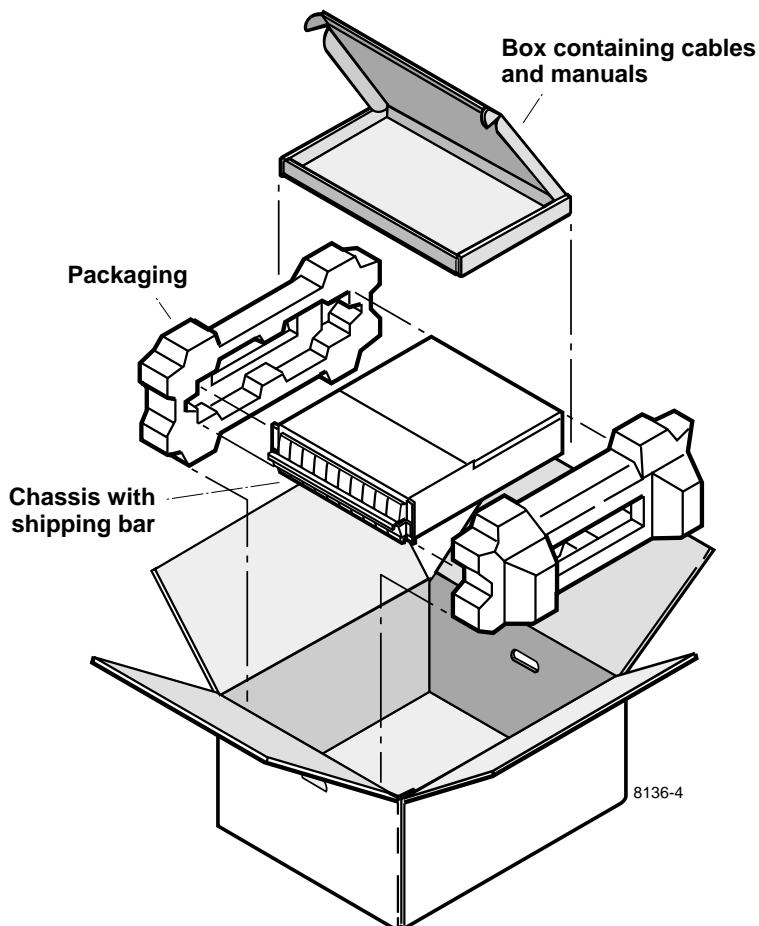

**CAUTION:** Save the chassis packaging. Use only PFR500 approved packaging to ship.

You can either remove the drive support bracket, as shown in the following figure so that you can hot-swap drives, or you can leave the bracket in place for greater drive stability. In either case, keep the bracket and retaining screws in case you have to ship the chassis in the future.

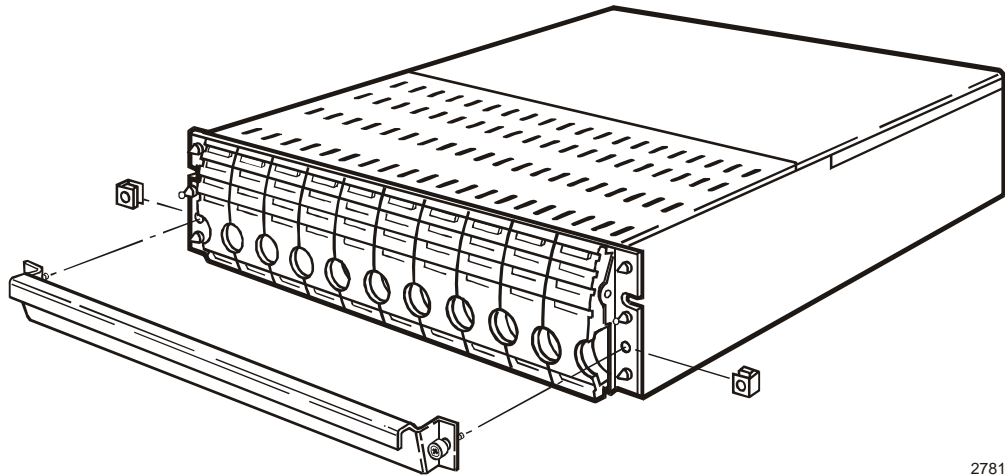

2781

## **Installing the rack mounts**

To install the PFR500/E rack mounts:

1. Loosely fasten the left stationary chassis mount to the left chassis slide rail with the locking nuts.
2. Adjust the length of the outside edges of the chassis mount assembly to fit between the front and back channel mounts. Secure these two pieces together. Pull chassis mount assembly away from channel mounts.
3. Place cage nuts around the top and bottom two holes on the front of the chassis mount assembly, such that the nuts are inside the front and the back of the chassis mount assembly.
4. Place one cage nut on the bottom hole, and one cage nut on the second hole from the top on the back, such that the nuts are inside the front and the back of the chassis mount assembly.
5. Slide the chassis mount assembly between the left front and back channel mounts. Secure the screws through the channel mounts into the cage nuts.

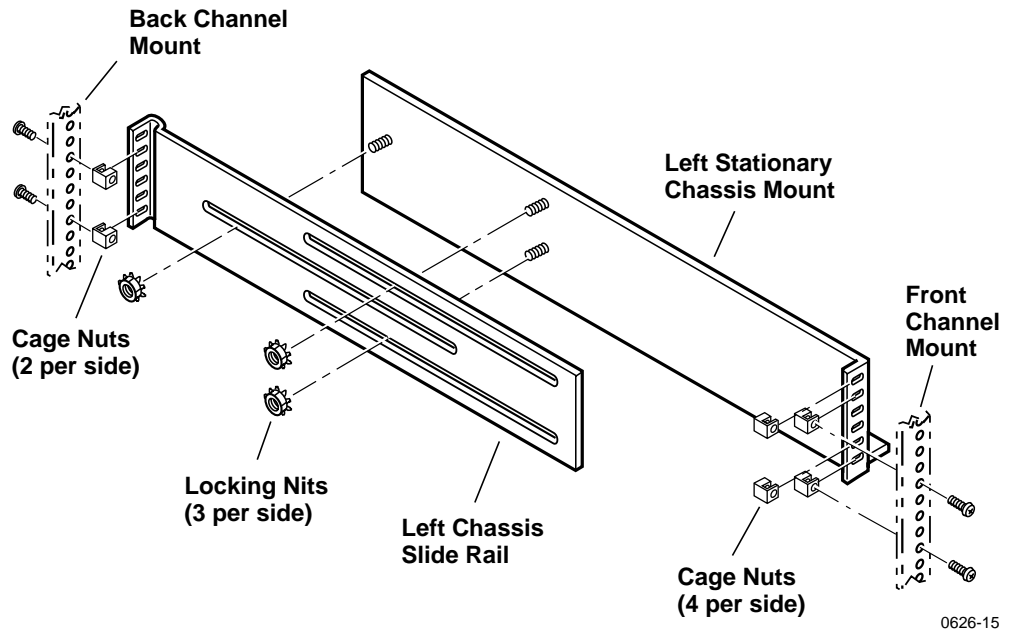

6. Repeat steps 1 through 5 for the right side.

## Inserting the PFR 500/E chassis in the rack

Every PFR500/E chassis ships with drive support brackets. The support bracket provides additional disk drive support. If the chassis will operate in a high-vibration area, leave the brackets on. This adds time when hot-swapping drives, but provides additional stability.

### Installing the chassis with drive the support bracket

To install a chassis with the drive support bracket:

1. Rest the chassis on the support angles shown. Slide the chassis back and into place.
2. Add the drive support bracket and secure the chassis to the rack with the mounting screws that shipped with the chassis.

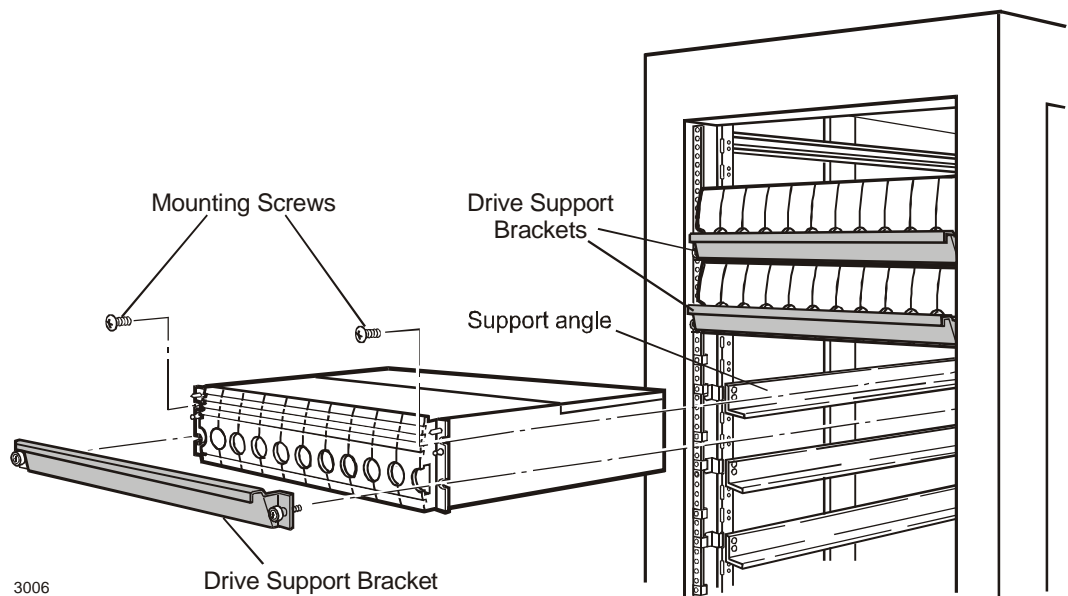

3. Repeat steps 1-2 to insert each PFR 500/E chassis in the rack.

The drive support brackets preclude edge covers.

### Installing chassis without the drive support bracket

To install a chassis without the drive support bracket:

1. Rest the chassis on the rack mounts as shown. Slide the chassis back and into place.
2. Secure the chassis to the rack with the mounting screws included in the installation kit.

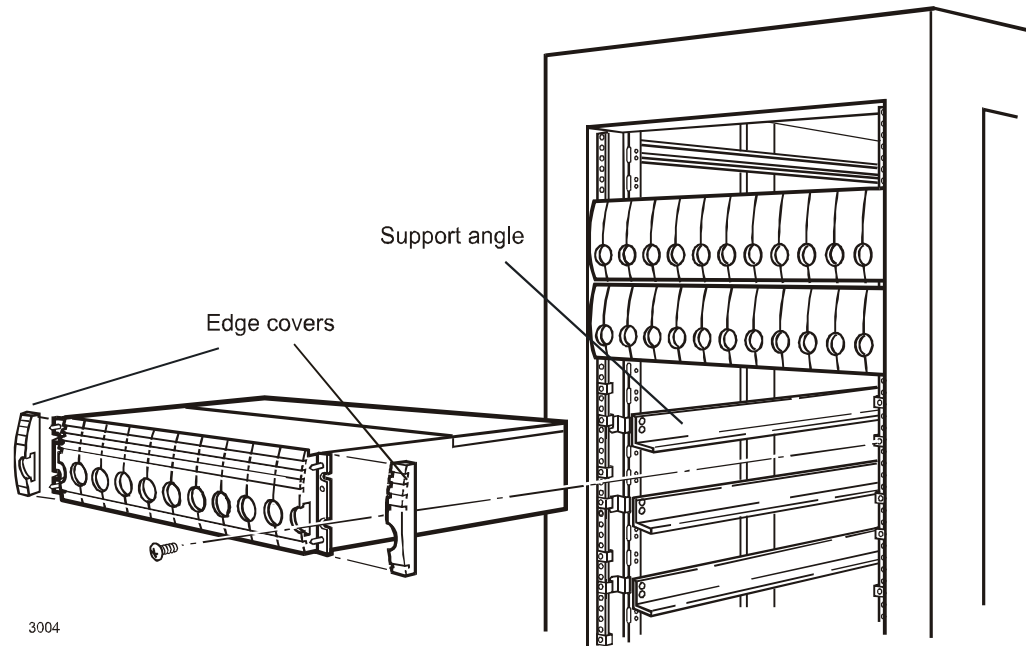

3. Apply the edge covers that are packaged with the PFR500/E.
4. Repeat steps 1-3 to install each PFR 500/E chassis in the rack.



## PFR 500/E power-up and initialization

This section gives information about connecting power and powering-on the PFR 500/E system.

### Connecting electrical cables

For each chassis, there are two electrical cables which should be connected to separate outside power sources, as shown.

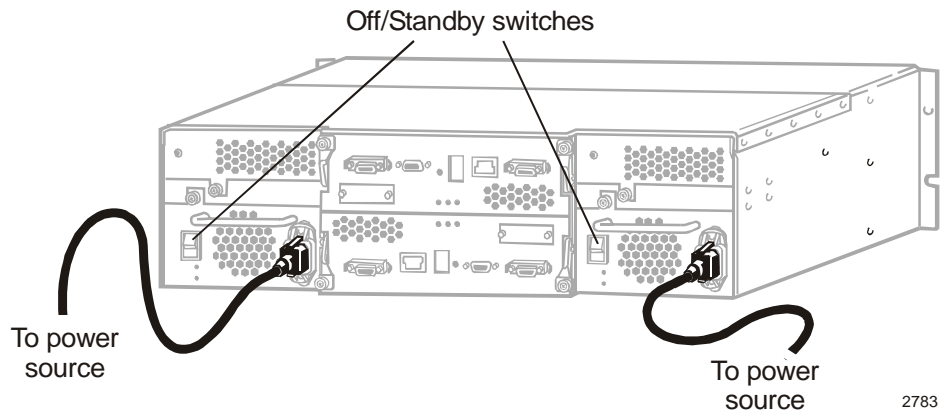

**WARNING:** Make sure the power cords meet local safety and electrical standards.



**CAUTION:** The PFR 500/E system must be electrically grounded. Operating the system without proper grounding can damage disk drives. If the outlet you use is not grounded, make sure that a licensed electrician replaces it and installs a grounding conductor.

### Powering-up the system

Power-up the PFR 500/E system beginning with the PFR 500E Expansion Chassis by turning on the standby switches.

When you power-up the PFR 500/E, the 7-segment LED display on the rear panel of the RAID Controller and Loop Bypass Boards shows a single digit (0 through 9). This indicates the chassis address of the chassis. The chassis displaying chassis address 0 contains drives from 0 to 9; the chassis displaying chassis address 1 contains drives from 10 to 19; and so forth. (If you must change chassis addresses, refer to your *PVS Series Installation Guide* or the *Media Area Network Instruction Manual*.)

After initialization, all disk drive LEDs will be green. This takes approximately 3 minutes. If there is a problem, refer to [“Servicing the PFR 500/E” on page 35](#).



## PFR 500/E power-down

To power-down the PFR 500/E correctly:

1. Stop any I/O activity to the PFR 500/E.
2. Shut off power to the ac distribution strips that supply the PFR 500/E.

The power in the distribution strips may be controlled by a circuit breaker located inside the cabinet (if the cabinet has such breakers) or may be controlled by a circuit breaker located externally to the cabinet.

To turn on power, refer to [“PFR 500/E power-up and initialization” on page 33](#).

## Battery Backup recharge

Every PFR 500/E RAID controller includes a backup battery so that if electrical power is lost, data stored in cache memory will be saved.

Data store cache is not used in Profile storage systems, so the Battery Backup module is not used, even though it ships as part of the LBB module.

## Chapter **3**

---

# ***Servicing the PFR500/E***

This chapter describes how to monitor PFR500/E status and replace Field Replaceable Units (FRU).

Topics are:

- [“Monitoring PFR500/E status” on page 36](#)
- [“Removing and installing disk drive modules” on page 38](#)
- [“Replacing the Loop Bypass Board \(LBB\) or RAID Controller” on page 41](#)
- [“Replacing GBIC data ports” on page 42](#)
- [“Replacing a power supply” on page 43](#)
- [“Replacing the fan module” on page 44](#)



## Monitoring PFR 500/E status

LEDs on PFR 500/E disk drive modules and FRUs are used to indicate status and error conditions. The disk drive LEDs are visible from the front, and other status LEDs are visible from the rear panel.

You can also monitor the PFR 500/E using Grass Valley Group's NetCentral software. Enabled by SNMP, NetCentral can continuously monitor the system and send notifications if there is a problem. Refer to the *Media Area Network Instruction Manual*, or *Profile XP Service Manual* for more information on monitoring the PFR 500 with NetCentral. These documents are available on the Grass Valley Group web site.

## Interpreting drive LED displays

The disk drive LEDs and the 7-segment display on the back of the RAID Controllers are used to indicate system status. The following table describes how to interpret the the disk drive LED behavior and rear panel 7-segment display for various conditions.

LEDs	7-Segment Display	Meaning
One drive is blue	none	Drive has been identified.
	F	Drive is failed.
One drive is red	none	Drive itself has determined it is bad.
All drives are alternating blue at two second intervals	F and chassis address (alternating)	Something (such as a power supply, blower, etc.) in the array failed.
RAID only: All drives are blue for 5 minutes, then green for 30 seconds	none	Failed drive in the array needs to be replaced.
RAID only: All drives are blue	none	System-wide failure has occurred. Do not remove a drive. Call Grass Valley Group Support as described in " <a href="#">Grass Valley Group Product Support</a> " on page 13.
One drive is green while all other drives are blinking blue.	Chassis ID	LUN is rebuilding. Do not power down the array until the rebuild finishes.

If a non-redundant FRU fails in a PFR 500, the system may be inoperable while you replace the FRU. If a redundant FRU fails, high availability will be compromised until you replace the faulty FRU.

## Interpreting rear panel LEDs

Refer to the following table to interpret rear panel LEDs on FRUs.

Module	LED Name	Meaning
Loop Bypass Board	Loop	LED is ON when the Fiber Channel port <b>does not</b> see a valid Fibre Channel signal on the GBIC.
RAID Controller	Host Loop	LED is ON when the Fiber Channel port <b>does not</b> see a valid Fibre Channel signal on the GBIC.
	Host RDY	LED is ON when the host is ready. LED off means the HOST is not ready.
	Disk ACT	LED is ON when there is disk activity.
	Host ACT	LED is ON when there is host activity.
Power Supply	Output Good	LED is ON when power supply output is good.
	Fault	LED is ON when there is a fault in the power supply.
Fan Module	Fault	LED is ON when there is a fan failure



## Removing and installing disk drive modules

Use the following instructions to replace a faulty disk drive module. It should be replaced while the array is running (hot-swapped).

**NOTE:** *Grass Valley Group does not support mixing disk drives of differing capacities within a RAID chassis connected to a Profile XP Media Platform or Media Area Network. All disk drives in any RAID chassis must be of the same capacity. For example, if a PFR500 and a PFR500E are used, all the disk drives in both the PFR500 and the PFR500E must be of the same capacity.*



**CAUTION:** *You can destroy a storage system beyond recovery if you move the wrong drive. The system operator or service person can move a disk module with the following cautions:*

- The disk module must be unbound.
- Moving a module that is part of a LUN to another slot makes all information on the LUN inaccessible.
- You must remove and install the disk module while the storage system is powered up.

A disk module must be inserted all the way or removed entirely. Do not leave a disk module partially removed except for periods when you are allowing it to spin down. When replacing multiple disks, observe the following:

- After removing a disk module, wait for the activity LEDs on the other disk modules to resume a steady flicker before removing the next module.
- After inserting a disk module, wait for the activity LEDs on the other drives to resume a steady flicker before inserting the next module.



**CAUTION:** *Handle a disk module gently and use an ESD wristband. Do not remove a faulty disk module until you have a replacement module (with the same part number) or a filler module available.*

## Removing a disk module

**NOTE:** *If a disk module has been bound into a LUN, do not move it to another slot unless you do not care about the data on the LUN. Each module has LUN identifying information written when it is bound. Moving it to another slot can make information on the original LUN inaccessible.*

Generally, you should not remove a disk module unless it is faulty. Refer to [“Monitoring PFR500/E status” on page 36](#).

To remove the disk module:

1. Confirm the drive location by ensuring that the disk drive LED is blue or red.  
NetCentral messages may report disk faults by disk module number. To locate a disk module by number, look at the 7-segment LED display on the rear panel of the RAID Controller or Loop Bypass Boards. It displays a single digit (0 through 9). This indicates the chassis address of the chassis. The chassis displaying chassis address 0 contains drives from 0 to 9; the chassis displaying chassis address 1 contains drives from 10 to 19; and so forth.
2. Remove the drive support bracket, if installed (refer to [“Installing the chassis with drive the support bracket” on page 31](#).)
3. Grasp the release lever with your thumb and index finger and pull outward to open the door.

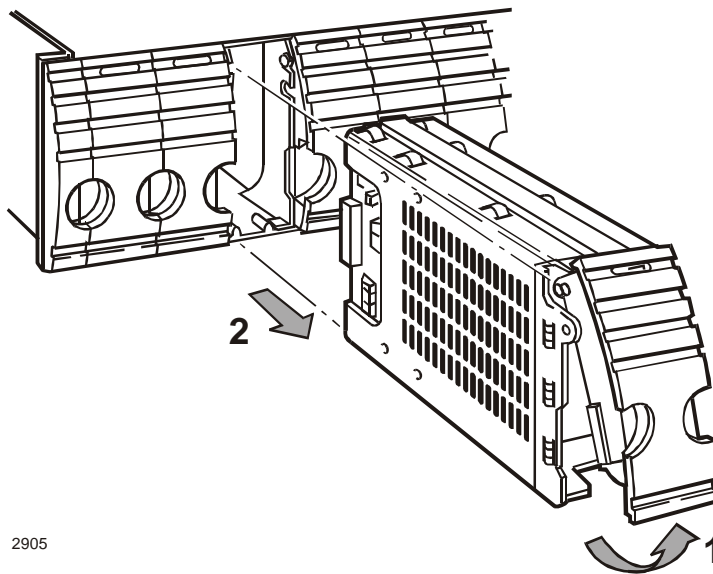

4. Carefully slide the disk module out until it is free and out of its bay.



## Installing disk module

To install a disk module:

1. Insert the replacement disk drive module into the empty bay, as shown.
2. Press the release lever down and into place.
3. The disk spins up automatically.
4. Replace the drive support bracket, if used (refer to [“Installing the chassis with drive the support bracket”](#) on page 31.)



## Replacing the Loop Bypass Board (LBB) or RAID Controller

Use the following instructions to replace an LBB or RAID Controller module. It should be replaced while the chassis is powered up (hot-swapped).

**NOTE:** A PFR500 must have at least one RAID Controller installed while it is powered up. Do not remove both RAID Controller while the PFR500 is powered up.

### Removing the LBB or RAID Controller

To remove the LBB or RAID Controller:

1. Identify the module to be replaced using NetCentral or rear panel LED indicators.
2. Remove the cables connected to the module.

**NOTE:** Note where the cables connect to the module.

3. Loosen captive screws as shown in the figure below.

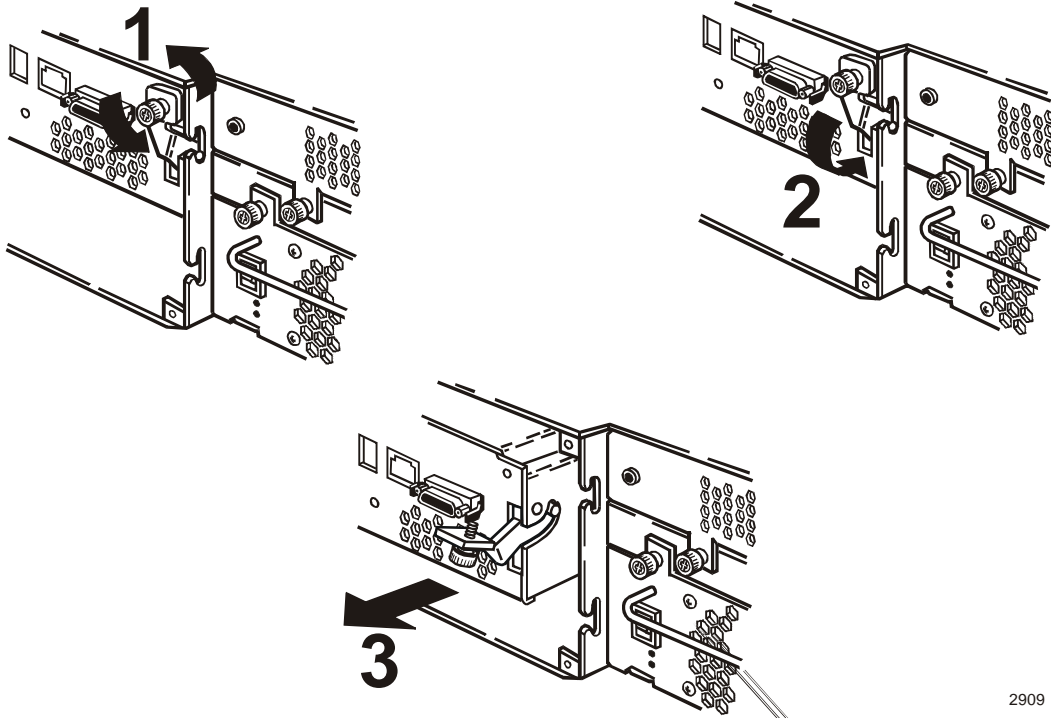

2909

4. Unseat the module by pushing down on the two ejector levers.
5. Pull the module out of the chassis.



## Installing the LBB or RAID Controller

To install the LBB or RAID Controller:

1. Insert the replacement into the empty bay. Make sure the module is seated.
2. Push up the two ejector levers to seat the module.
3. Tighten the captive screws.

## Replacing GBIC data ports

The PFR 500/E ships with passive copper data ports installed in the RAID Controller and Loop Bypass Board (LBB) modules.

To replace the GBIC:

1. Remove cabling and remove the GBIC as shown.
2. Insert the replacement GBIC into the module as shown, then reconnect cabling.

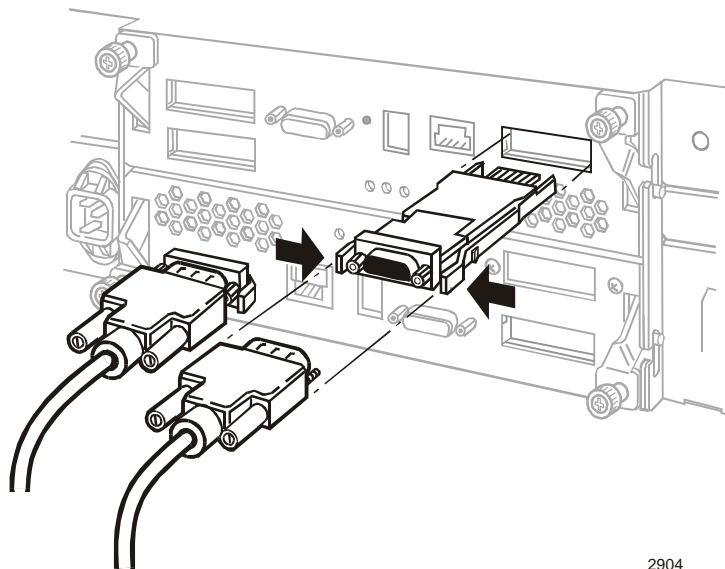

2904

## Replacing a power supply

 **CAUTION:** Turn off the power supply before unplugging the power cord from the supply or removing the supply from the chassis.

To replace the power supply:

1. Turn the standby switch to Standby (0), as shown.

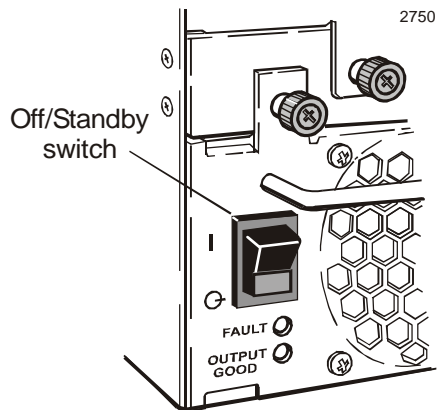

2. Remove the electrical cable from the power supply.
3. Loosen the captive screw on the power supply.
4. Pull the module out of the enclosure, as shown.

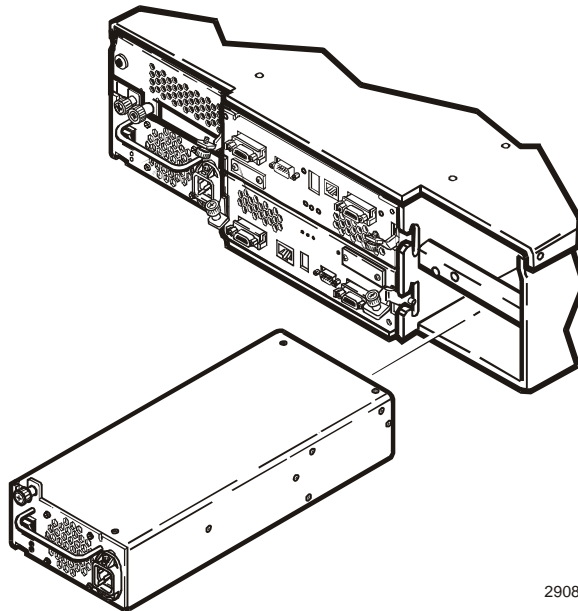

5. Insert the replacement power supply into the empty bay.
6. Tighten the captive screw on the power supply.



7. Plug the electrical cable into the power supply.
8. Turn on the power supply. Turn the standby switch to ON (1).

## Replacing the fan module

**CAUTION:** Do not remove a faulty fan module until you have a replacement fan module available. You can remove the drive fan module while the PFR500/E is powered up.

To replace a fan module:

1. Loosen the captive screw on the fan module.
2. Pull the module out of the enclosure.
3. Insert the replacement fan module into the empty bay.
4. Tighten the captive screw on the module.

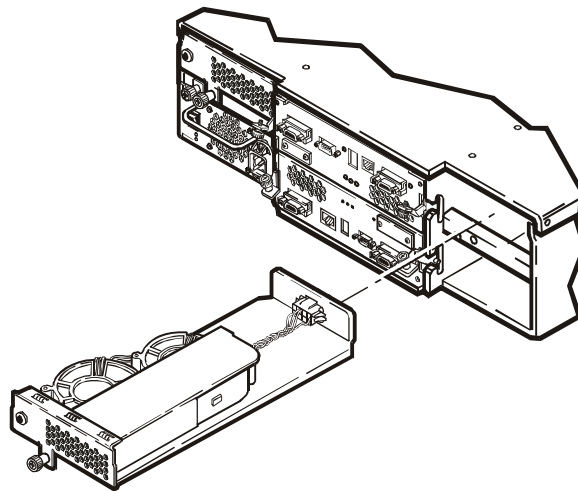

2907

As soon as the module is reinstalled, the fans start spinning and the system fault indicators are cleared if no other FRUs are faulty.

# Technical Specifications and Operating Limits

## AC power requirements

Power Input
100-120 VAC, 50/60Hz, 6amps
200-240 VAC, 50/60Hz, 3 amps

If one of the two power supplies fails, the remaining supply and cord must support the full load. Your rackmount cabinet must include ac power distribution that can handle these values.

## Size and weight

Item	Measurement
Height	13.34 cm (5.25 in) (3 rack units)
Width	44.83 cm (17.65 in)
Depth	55.88 cm (22 in)
Weight	34.0 kg (75.0 lbs)

## Copper cable lengths

It is recommended that you use the copper Fibre Channel cables shipped with your PFR500 when making connections.

Any copper cables you use must meet the appropriate standards for 1-Gbit FC-AL loops. Such cables are fully shielded, twin-axial, full-duplex cables with DB-9 connectors. Cables greater than 10 meters must be equalized; cables equal to or less than 10 meters do not need to be equalized. Do not use copper cables longer than 15 meters for any Fibre Channel connection in a Profile system.



## Environmental limits

Requirements	Description
Temperature (Operating)	5 to 35 degrees C (41 to 95 degrees F)
Temperature (Non-operating)	-40 to 65 degrees C (-40 to 149 degrees F)
Relative Humidity (Operating)	5 to 75%, non-condensing
Relative Humidity (Non-operating)	5 to 95%, non-condensing

The system includes two temperature level sensors used to issue auto-warning and auto-shutdown incase the over temperature limit is reached.

# Index

---

## Numerics

9-pin cable 22

## A

AC power

current draw 45

overview 25

address switch, chassis 26

Authorized support representative 13

## B

Battery Backup Unit 17, 34

binding disk modules 27

blinking disk module LEDs 36

blue drive LED, blinking 36

## C

cabling

max lengths 27, 45

requirements 27

cabling requirements 27, 45

Canadian Certified Power Cords 7

Canadian EMC Notice of Compliance 7

capacity 16

chassis address switch 26

chassis description 18

chassis dimensions 45

chassis weight 45

colors, disk module LEDs 36

components 16

See FRUs (field replaceable units)

configurations 23

console program 21, 22

## D

depth, chassis 45

disk drive LED displays, interpreting 36

disk module

description 19

disk drive LED colors 36

identification 18

installing 40

removing 39

replacing 38

disk utilities 27

documentation set 9

documentation, online 12

drive support bracket 31

## E

ejector lever 41

Emission Control, compliance 7

EN55022 Class A Warning 7

Ethernet connector 21, 22

## F

fan module

description 23

replacing 44

running in standby 23

status LEDs 37

FC-AL (Fibre Channel Arbitrated Loop)

cabling requirements 27

FCC Emission Limits 7, 8

features 15

Fibre Channel Host Port 22

Fibre Channel Loop Port 22

field replaceable units (see FRUs)

flashing disk module LEDs 36

FRUs (field-replaceable units)

defined 16

disk module

description 19

replacing 38

fan module

description 23

replacing 44

GBIC

description 20

replacing 42

Loop Bypass Board

description 20

replacing 41

power supply

description 22

replacing 43

RAID Controller



description 21  
replacing 41

## G

GBIC 21, 22, 42  
General Safety Summary 5

## H

height, chassis 45  
high availability features 16

## I

Injury Precautions 5  
installing  
    disk module 40  
    PFR500/E 28

## L

Laser Compliance  
    FCC Emission Limits 7, 8

## LBB

see Loop Bypass Board

## LEDs

disk modules 36  
rear panel 37

## Loop Bypass Board

description 20  
replacing 41  
status LEDs 37

loose cable 27

## M

midplane board  
    chassis address switch 26  
    description 18

## N

NetCentral 36

## O

online documentation 12

## P

packaging 28  
PFR500/E  
    chassis

midplane 18

chassis depth 45  
components 16  
configurations 23  
description 16  
disk module description 19  
fan modules 23  
high availability features 16  
installation requirements 25  
installing in rack 31  
monitoring status 36  
operating limits 46  
power supply, description 22  
powering down 34  
rear panel view 20, 21  
requirements  
    cabling 27  
    operating 46  
weight 45

## power

cord 33  
outlet 33

## power supply

description 22  
replacing 43  
status LEDs 37

powering-up 33

Product Damage Precautions 5

Profile Users Group 13

## R

rack mounting 28

RAID configuration 27

## RAID Controller

description 21  
replacing 41  
status LEDs 37

remote monitoring 36

## replacing

disk module 38  
fan module 44  
GBIC 42  
Loop Bypass Board 41  
power supply 43  
RAID Controller 41



---

## **S**

safety ground 33

Safety Terms and Symbols 6

serial port 21, 22

seven-segment display 27

site requirements

    See also Appendix A

    see also Appendix A

size and weight 45

SNMP monitoring 36

standby switch 33, 43

status

    monitoring PFR500/E 36

storage capacity 16

support, phone numbers 13

## **T**

technical support 13

## **U**

users group 13

## **V**

voltage, PFR 500/E requirements 45

## **W**

web site 13

weight, chassis 45

width, chassis 45

